

Electrical and Electronics Measurements and Instrumentation

About the Authors



Prithwiraj Purkait obtained his BEE, MEE and PhD degrees from Jadavpur University, Kolkata. He worked with M/s Crompton Greaves Ltd, Mumbai, as a Design Engineer for one year. He was involved in post-doctoral research in the University of Queensland, Australia, during 2002-2003, and as Visiting Academic Research Fellow during 2005 and 2007. Presently, he is Professor, Department of Electrical Engineering and Dean, School of Engineering, at Haldia Institute of Technology, Haldia, West Bengal. His current areas of interest include PC/DSP based instruments, motion and industrial process control, insulation-condition assessment techniques and advanced signal-processing applications. Dr Purkait has published extensively in international journals and conference proceedings on various topics related to his research paradigm.



Budhaditya Biswas obtained his BEE and MEE from University of Kalyani, Nadia and Bengal Engineering and Science University (BESU), Shibpur, in the years 2002 and 2006 respectively. He started his career as a lecturer in Haldia Institute of Technology, Haldia, in 2006. At present, he is working as Assistant Professor at the Department of Electrical Engineering in RCC Institute of Information Technology, Kolkata. He has been teaching for over 6 years and his areas of interest include power systems, especially the design of microcontroller-based numerical adaptive relay, digital instrumentation, and data acquisition. He has to his credit publications in international and national conference proceedings on various topics related to his research domain.



Santanu Das obtained his BEE and MEE from Bengal Engineering and Science University, Howrah, West Bengal. He has submitted his PhD thesis (in electrical engineering) to Jadavpur University, Kolkata, for evaluation. Earlier, Prof. Das worked at

Asansol Engineering College, Asansol, as Lecturer. Presently, he holds the post of Associate Professor and Head, Department of Electrical Engineering Haldia Institute of Technology, Haldia. He has published more than 20 research papers in international journals and conference proceedings on topics related to his research domains. His current fields of research interest include fault diagnosis and condition monitoring of electric motors, PLC and microcontroller-based motion control, power electronics and drives.



Chiranjib Koley obtained his B.Tech from HIT, Haldia, M.Tech from IIT Delhi and PhD from Jadavpur University, Kolkata. He received the EFIP Scholarship in 2001 from the Government of India. Presently, he is Associate Professor in Department of Electrical Engineering, National Institute of Technology, Durgapur, West Bengal. His current areas of interest include signal processing, machine learning, and measurement and instrumentation. He has published extensively in national and international journals, and conference proceedings on various topics related to his research areas.

Electrical and Electronics Measurements and Instrumentation

Prithwiraj Purkait

Professor

Department of Electrical Engineering and

Dean, School of Engineering

Haldia Institute of Technology

Haldia, West Bengal

Budhaditya Biswas

Assistant Professor

Department of Electrical Engineering

RCC Institute of Information Technology

Kolkata, West Bengal

Santanu Das

Associate Professor

Department of Electrical Engineering

Haldia Institute of Technology

Haldia, West Bengal

Chiranjib Koley

Associate Professor

Electrical Engineering Department

National Institute of Technology (NIT) Durgapur

Durgapur, West Bengal



McGraw Hill Education (India) Private Limited

NEW DELHI

McGraw Hill Education Offices

New Delhi New York St Louis San Francisco Auckland Bogotá Caracas
Kuala Lumpur Lisbon London Madrid Mexico City Milan Montreal
San Juan Santiago Singapore Sydney Tokyo Toronto



McGraw Hill Education (India) Private Limited

Published by McGraw Hill Education (India) Private Limited

P-24, Green Park Extension, New Delhi 110 016

Electrical and Electronics Measurements and Instrumentation

Copyright © 2013, by McGraw Hill Education (India) Private Limited.

No part of this publication may be reproduced or distributed in any form or by any means, electronic, mechanical, photocopying, recording, or otherwise or stored in a database or retrieval system without the prior written permission of the publishers. The program listing (if any) may be entered, stored and executed in a computer system, but they may not be reproduced for publication.

This edition can be exported from India only by the publishers,

McGraw Hill Education (India) Private Limited.

ISBN (13): 978-1-25-902959-2

ISBN (10): 1-25-902959-X

Vice President and Managing Director: *Ajay Shukla*

Head—Higher Education Publishing and Marketing: *Vibha Mahajan*

Publishing Manager—SEM & Tech. Ed: *Shalini Jha*

Editorial Executive: *Koyel Ghosh*

Manager—Production Systems: *Satinder S Baveja*

Assistant Manager—Editorial Services: *Sohini Mukherjee*

Senior Production Manager: *P L Pandita*

Assistant General Manager (Marketing)—Higher Education: *Vijay Sarathi*

Senior Product Specialist: *Tina Jajoriya*

Senior Graphic Designer—Cover: *Meenu Raghav*

General Manager—Production: *Rajender P Ghansela*

Manager—Production: *Reji Kumar*

Information contained in this work has been obtained by McGraw Hill Education (India), from sources believed to be reliable. However, neither McGraw Hill Education (India) nor its authors guarantee the accuracy or completeness of any information published herein, and neither McGraw Hill Education (India) nor its authors shall be responsible for any errors, omissions, or damages arising out of use of this information. This work is published with the understanding that McGraw Hill Education (India) and its authors are supplying information but are not attempting to render engineering or other professional services. If such services are required, the assistance of an appropriate professional should be sought.

Typeset at Text-o-Graphics, B-1/56, Aravali Apartment, Sector-34, Noida 201 301, and printed at

Cover Printer:

Contents

Preface

Guided Tour

1. Concept of Measurement Systems

- 1.1 Introduction
- 1.2 Fundamental and Derived Units
- 1.3 Standards and their Classifications
- 1.4 Methods of Measurement
- 1.5 Measurement System and its Elements
- 1.6 Classification of Instruments
- 1.7 Definitions of Some Static Characteristics
- 1.8 Measurement of Errors
- 1.9 Loading Effects

Exercise

2. Analog Meters

- 2.1 Introduction
- 2.2 Classification of Analog Instruments
- 2.3 Principle of Operation
- 2.4 Operating Torques
- 2.5 Constructional Details
- 2.6 Permanent Magnet Moving Coil Instrument
- 2.7 Extension of Range of PMMC Instruments
- 2.8 Moving-Iron Instruments
- 2.9 Electrodynamometer-Type Instruments
- 2.10 Electrostatic Instruments
- 2.11 Induction-type Instruments
- 2.12 Electrothermal Instruments
- 2.13 Rectifier-type Instruments
- 2.14 True rms Voltmeter
- 2.15 Comparison between Different Types of Instruments

Exercise

3. Instrument Transformers

- 3.1 Introduction
- 3.2 Advantages of Instrument Transformers
- 3.3 Current Transformers (CT)
- 3.4 Theory of Current Transformers
- 3.5 Errors Introduced by Current Transformers
- 3.6 Operational Characteristics of Current Transformers
- 3.7 Design and Constructional Features of Current Transformers
- 3.8 Precautions in Use of Current Transformer
- 3.9 Potential Transformers (PT)
- 3.10 Theory of Potential Transformers
- 3.11 Errors Introduced by Potential Transformers
- 3.12 Operational Characteristics of Potential Transformers
- 3.13 Design and Constructional Features of Potential Transformers
- 3.14 Differences between CT and PT

Exercise

4. Measurement of Resistance

- 4.1 Introduction
- 4.2 Measurement of Medium Resistances
- 4.3 Measurement of Low Resistances
- 4.4 Measurement of High Resistances
- 4.5 Localisation of Cable Faults

Exercise

5. Potentiometers

- 5.1 Introduction
- 5.2 A Basic dc Potentiometer
- 5.3 Crompton's dc Potentiometers
- 5.4 Applications of dc Potentiometers
- 5.5 AC Potentiometers
- 5.6 Classification of AC Potentiometers
- 5.7 Advantages and Disadvantages of AC Potentiometers
- 5.8 Applications of AC Potentiometer

Exercise

6. AC Bridges

- 6.1 Introduction
- 6.2 Sources and Detectors in AC Bridges
- 6.3 General Balance Equation for Four-Arm Bridge
- 6.4 Measurement of Self-Inductance
- 6.5 Measurement of Capacitance
- 6.6 Measurement of Frequency
- 6.7 Wagner Earthing Device

Exercise

7. Power Measurement

- 7.1 Introduction
- 7.2 Power Measurement in dc Circuits
- 7.3 Power Measurement in ac Circuits
- 7.4 Electrodynamicometer Type Wattmeter
- 7.5 Induction-type Wattmeter
- 7.6 Power Measurement in Polyphase Systems
- 7.7 Power Measurement in Three-Phase Systems
- 7.8 Reactive Power Measurements
- 7.9 Power Measurement with Instrument Transformers

Exercise

8. Measurement of Energy

- 8.1 Introduction
- 8.2 Single-Phase Induction-type Energy Meter
- 8.3 Errors in Induction-type Energy Meters and Their Compensation
- 8.4 Testing of Energy Meters

Exercise

9. Cathode Ray Oscilloscope

- 9.1 Introduction
- 9.2 Block Diagram of a Cathode Ray Tube (CRT)
- 9.3 Electrostatic Deflection

- 9.4 Time Base Generator
- 9.5 Vertical Input and Sweep Generator Signal Synchronisation
- 9.6 Measurement of Electrical Quantities with CRO
- 9.7 Measurement of Voltage and Current
- 9.8 Measurement of Frequency
- 9.9 Measurement of Phase Difference
- 9.10 Sampling Oscilloscope
- 9.11 Storage Oscilloscope
- 9.12 Multi-Input Oscilloscopes
- 9.13 Frequency Limitation of CRO

Exercise

10. Electronic Instruments

- 10.1 Introduction
- 10.2 Merits and Demerits of Digital Instruments over Analog Ones
- 10.3 Performance Characteristics of Digital Meters
- 10.4 Digital Multimeter
- 10.5 Digital Frequency Meter
- 10.6 Digital Voltmeters (DVMs)
- 10.7 Signal Generators

Exercise

11. Sensors and Transducers

- 11.1 Introduction
- 11.2 Electrical Transducers
- 11.3 Linear Variable differential Transformer (LVDT)
- 11.4 Strain Gauges
- 11.5 Electromagnetic Flow Meter
- 11.6 Temperature Transducers
- 11.7 Pressure Measurement

Exercise

12. Magnetic Measurements

- 12.1 Introduction
- 12.2 Types of Magnetic Measurements

- 12.3 The Ballistic Galvanometer
- 12.4 Fluxmeter
- 12.5 Uses of Ballistic Galvanometer and Fluxmeter
- 12.6 Measurement of Flux Density
- 12.7 Measurement of Magnetising Force (H)
- 12.8 Determination of Magnetising Curve
- 12.9 Determination of Hysteresis Loop
- 12.10 Testing of Specimens in the Form of Rods or Bars
- 12.11 Permeameters
- 12.12 Measurement of Magnetic Leakage
- 12.13 Magnetic Testing with Alternating Current
- 12.14 Bridge and ac Potentiometer Methods
- 12.15 Magnetic Shielding

Exercise

13. Signal Generators and Analysers

- 13.1 Introduction
- 13.2 Oscillators
- 13.3 Hartley Oscillator
- 13.4 Colpitts Oscillators
- 13.5 The RC Oscillator
- 13.6 Wien Bridge Oscillators
- 13.7 Crystal Oscillators
- 13.8 Pierce Oscillator
- 13.9 Microprocessor Clocks
- 13.10 Square Wave and Pulse Generators
- 13.11 Triangular Wave Generator
- 13.12 Sine-Wave Generator
- 13.13 Function Generators
- 13.14 RF Signal Generator
- 13.15 Sweep Frequency Generator
- 13.16 Wave Analyser
- 13.17 Harmonic Distortion Analysers

13.18 Spectrum Analyser

Exercise

14. Data Acquisition System

14.1 Introduction

14.2 Basic Components of Data Acquisition Systems

14.3 Components of a Typical PC-based Data Acquisition System

14.4 Analog Input Subsystem

14.5 Analog Output Subsystem

14.6 Digital Input and Output Subsystem

14.7 IEEE 488 Interface

Exercise

15. Recording, Storage and Display Devices

15.1 Introduction

15.2 Analog Recorders

15.3 Digital Recorders

15.4 Display System

Exercise

16. Programmable Logic Controllers

16.1 Introduction

16.2 Advantages of PLCs

16.3 The Control Program

16.4 Function of each Part in PLC

16.5 Hardware of PLC

16.6 System Addressing

16.7 PLC Operation and Program Scan

16.8 Implementation of Control Programs in PLC

16.9 More in Ladder Logic

Exercise

17. Microwave and RF Measurement

17.1 Introduction to RF and Wireless Communication System

17.2 Radio Frequency and Microwave Spectral Analysis

- 17.3 Radio Frequency Spectrum Analyser
- 17.4 RF Scalar and Vector Network Analyser
- 17.5 Modulation
- 17.6 Communication Systems
- 17.7 RF Voltage and Power Measurement

Exercise

18. Fibre Optic Measurements

- 18.1 Introduction
- 18.2 How does an Optical Fibre Work?
- 18.3 Sources and Detectors
- 18.4 Fibre Optic Power Measurement

Exercise

Appendix A Table of SI Units

Appendix B Number Systems

Appendix C Weston Frequency Meter

Solved Sample Question Papers

Index

Preface

Overview

This book can be used as a textbook for the course in electrical and electronics measurements and instrumentation. It presents a comprehensive treatment of the subject of electrical and electronics measurements and instrumentation as taught to the undergraduate students of B.Tech/BE in Electrical Engineering, Electrical and Electronics Engineering, Instrumentation Engineering, and allied branches. The book thus aims at maintaining balance between these diverse fields of engineering disciplines by drawing examples from various applications. The prerequisite on the part of the reader is that he or she should have had introductory courses on linear algebra, basic calculus, vector/phasor analysis, transform theory, circuit analysis and elementary mechanics. For the students' interest, appendices on number systems and unit conversions are added at the end.

Aim

While conceptualising the text, the authors felt that the scope and method of treatment could, with advantage, be augmented to suit the requirements of various branches of engineering. Owing to the rapid advancements taking place in modern electrical and allied industries, and their interconnection with power systems, the subject of electrical and electronics measurements is gaining an ever-increasing importance.

About the Book

As a subject of study, electrical measurement is one of the more traditional fields of electrical and allied engineering disciplines. However, with progress in technology and manufacturing expertise, measurements of physical parameters have gained new heights in terms of state-of-the-art concepts and technologies. This book aims at bridging traditional concepts with modern technologies of electrical and electronics measurements and instrumentation.

The text is designed for an undergraduate course in electrical and electronics measurements. Since the basic concepts cut across disciplines—such as electrical, mechanical, electronics, instrumentation and control engineering—this book presents a proper balance between theoretical and analytical approach, as well as practical illustrations along with computational approach for solving various kinds of numerical problems. Some of the subjects dealt with are essentially mathematical in nature, and cannot be treated otherwise, but the mathematics throughout the book has been kept as simple as possible so that it is followed easily by most readers. The theory of most of the measurement techniques and measuring instruments has been dealt with in sufficient detail, but in most cases concise forms have been used for such theoretical discussions, so that readers may skip them, if desired, and consider only the resulting expressions. Photographs of real systems have been used in places where schematic representation needed to be augmented.

The main theme of this book has been to cater to undergraduate students. All topics in different chapters have been developed with ample and adequate detail without subjecting students to unwanted complications. As a textbook, this contribution is expected to help

students not only in building up their knowledge of physical concepts of the systems described, but also as a ready and concise reference.

Salient Features

- ❖ Coverage bridges traditional concepts with modern technologies in the subject area
- ❖ Comprehensive discussions on electronic measurement systems and related components including analysers, data acquisition systems, etc.
- ❖ Special-purpose measurements and applications such as magnetic measurements and fibre optic measurements covered
- ❖ Dedicated chapter on Sensors and Transducers
- ❖ Inclusion of real-life photographs to augment schematic diagrams wherever necessary
- ❖ Solved question papers from 9 universities
- ❖ Rich pedagogy
 - Illustrations: 400
 - Solved Examples: 100
 - Objective-type Questions: 236
 - Short-Answer-Type Questions: 164
 - Long-Answer-Type Questions: 119

Chapter Organisation

The entire text is organised into 18 chapters. Chapter organisation has been primarily based on the electrical and electronic measurement syllabi in BE/B.Tech undergraduate courses of universities around the country. The outline of the book can be organised in the following four major parts:

1. General concepts of measurement
2. Electrical measurement techniques and classical measuring instruments
3. Modern measurement techniques and instruments
4. Brief concepts of sensors and transducers
5. Electronic measurement systems and related components including signal generators, analysers, data acquisition systems, storage and display devices and programmable logic controllers
6. Applications of the concepts of electrical and electronic measurement systems in special-purpose measurements including magnetic measurements, fibre optic measurements, RF and microwave measurements.

Within this framework, a more in-depth breakdown can be obtained from the table of contents. Detailing in the table of content will be useful for the instructors and students to select parts of the text that might be appropriate for the specific need at hand. In places where illustrations and explanations have been summarised, the adequate list of reference at the end will enable enthusiastic readers to probe further. The fluid flow of text dealing

with different topics has been well thought out by the authors who have several years of experience in teaching the subject directly to undergraduate students. Illustrations, examples, questions, highlights, exercises, numerical problems are extremely relevant and appropriate for students as well as instructors. The main strength of the book thus is its strong focus towards students' readability and understanding with the scope for independent study and problem-solving skill development. The authors are confident that the depth of this book has been judiciously developed so that students not only treat this as a textbook, but, in addition, can also gather enough practical and theoretical knowledge to appear in national-level competitive examinations and interviews.

Web Supplements

The text is supplemented with an exhaustive Online Learning Center, which can be accessed at <https://www.mhhe.com/purkait/eemi>

It contains PowerPoint lecture slides and the Solution Manual.

Acknowledgements

We are thankful to all those who have directly or indirectly helped us in bringing out this book. First, we would like to thank the reviewers who through various instances have provided comments that have shaped this book. Their names are given below:

Nilesh Chaurasia	<i>Sri Vaishnav Institute of Technology and Science, Indore, Madhya Pradesh</i>
Saurabh Basu	<i>GLA University, Mathura, Uttar Pradesh</i>
Praveen Tiwari	<i>IMIT College, Meerut, Uttar Pradesh</i>
S B L Seksena	<i>National Institute of Technology (NIT) Jamshedpur, Jharkhand</i>
Suwendu Naryan Mishra	<i>Veer Surendra Sai University of Technology (VSSUT), Burla, Odisha</i>
Samir Ekbote	<i>Datta Meghe College of Engineering, Navi Mumbai, Mumbai, Maharashtra</i>
V G Sarode	<i>Xavier Institute of Engineering, Mumbai, Maharashtra</i>
C D Kapse	<i>Wattmull Institute of Engineering and Computer Technology, Mumbai, Maharashtra</i>
Ruban N	<i>Vellore Institute of Technology (VIT) University, Vellore, Tamil Nadu</i>

Subhash Krishnamoorthy

*National Institute of Technology (NIT), Calicut,
Tamil Nadu*

R S Varadhan

*ICFAI Institute of Technology & Science, Hyderabad,
Andhra Pradesh*

K E Srinivas Murthy

*Sri Venkateswara Institute of Technology,
Ananthapur, Andhra Pradesh*

C H Madhuri

*Sri Indu College of Engineering, Hyderabad, Andhra
Pradesh*

Thanks are also due to the staff at McGraw Hill Education (India) for bringing out this book in such a short time. Finally, we would like to thank our respective family members whose patience and love was a source of encouragement during the preparation of this manuscript.

Suggestions for improvements will always be welcome.

PRITHWIRAJ PURKAIT

BUDHADITYA BISWAS

SANTANU DAS

CHIRANJIB KOLEY

Publisher's Note

Do you have any further request or a suggestion? We are always open to new ideas (the best ones come from you!). You may send your comments to tmh.elefeedback@gmail.com

Piracy-related issues may also be reported!

Guided Tour

Comprehensive Topical Coverage

- The text focuses on detailed coverage of electronics measurement systems and related components including analysers, data acquisition systems, etc.
- In-depth discussion on special-purpose measurements and applications such as magnetic measurements and fibre optic measurements
- Dedicated chapter on *Sensors and Transducers*

14 Data Acquisition System

14.1 INTRODUCTION

A data acquisition system is a computer system that is used to collect and process data from various sensors and transducers. It is used in a wide range of applications, including scientific research, industrial process control, and medical diagnosis.

The main components of a data acquisition system are the sensors, the data acquisition card, and the computer. The sensors convert the physical quantity to be measured into an electrical signal. The data acquisition card converts this signal into a digital format. The computer then processes the data.

The main components of a data acquisition system are the sensors, the data acquisition card, and the computer. The sensors convert the physical quantity to be measured into an electrical signal. The data acquisition card converts this signal into a digital format. The computer then processes the data.

The main components of a data acquisition system are the sensors, the data acquisition card, and the computer. The sensors convert the physical quantity to be measured into an electrical signal. The data acquisition card converts this signal into a digital format. The computer then processes the data.

14.2 BASIC COMPONENTS OF DATA ACQUISITION SYSTEMS

The main components of a data acquisition system are the sensors, the data acquisition card, and the computer.

- Sensors
- Data Acquisition Card
- Computer

18 Fibre Optic Measurements

18.1 INTRODUCTION

Fibre optic measurements are used to measure the properties of light as it travels through a fibre optic cable. This is done by measuring the time it takes for light to travel a certain distance, or by measuring the intensity of light as it travels through a fibre optic cable.

18.2 HOW DOES AN OPTICAL FIBRE WORK?

An optical fibre is a thin, flexible strand of glass or plastic that is used to transmit light. It works by reflecting light off the walls of the fibre, which are coated with a reflective material.

When light enters a fibre, it is reflected off the walls of the fibre. This is because the walls of the fibre are coated with a reflective material. The light travels through the fibre until it reaches the end, where it is collected and processed.

$$n_1 \sin \theta_1 = n_2 \sin \theta_2$$

(18.1)

Signal Generators and Analysers

13

13.1 INTRODUCTION

Signal generators and analysers are used to generate and measure electrical signals. They are used in a wide range of applications, including scientific research, industrial process control, and medical diagnosis.

1. A signal generator is a device that generates an electrical signal of a specific frequency and amplitude.
2. A signal analyser is a device that measures the frequency and amplitude of an electrical signal.
3. Signal generators and analysers are used in a wide range of applications, including scientific research, industrial process control, and medical diagnosis.

Signal generators and analysers are used to generate and measure electrical signals. They are used in a wide range of applications, including scientific research, industrial process control, and medical diagnosis.

13.2 OSCILLATORS

Oscillators are used to generate a periodic electrical signal. They are used in a wide range of applications, including scientific research, industrial process control, and medical diagnosis.

Oscillators are used to generate a periodic electrical signal. They are used in a wide range of applications, including scientific research, industrial process control, and medical diagnosis.

Oscillators are used to generate a periodic electrical signal. They are used in a wide range of applications, including scientific research, industrial process control, and medical diagnosis.

12

Magnetic Measurements

12.1 INTRODUCTION

Magnetic measurements are used to measure the properties of magnetic fields. They are used in a wide range of applications, including scientific research, industrial process control, and medical diagnosis.

Magnetic measurements are used to measure the properties of magnetic fields. They are used in a wide range of applications, including scientific research, industrial process control, and medical diagnosis.

Magnetic measurements are used to measure the properties of magnetic fields. They are used in a wide range of applications, including scientific research, industrial process control, and medical diagnosis.

Magnetic measurements are used to measure the properties of magnetic fields. They are used in a wide range of applications, including scientific research, industrial process control, and medical diagnosis.

Magnetic measurements are used to measure the properties of magnetic fields. They are used in a wide range of applications, including scientific research, industrial process control, and medical diagnosis.

Magnetic measurements are used to measure the properties of magnetic fields. They are used in a wide range of applications, including scientific research, industrial process control, and medical diagnosis.

Magnetic measurements are used to measure the properties of magnetic fields. They are used in a wide range of applications, including scientific research, industrial process control, and medical diagnosis.

Magnetic measurements are used to measure the properties of magnetic fields. They are used in a wide range of applications, including scientific research, industrial process control, and medical diagnosis.

Magnetic measurements are used to measure the properties of magnetic fields. They are used in a wide range of applications, including scientific research, industrial process control, and medical diagnosis.

11

Sensors and Transducers

11.1 INTRODUCTION

Sensors and transducers are used to convert a physical quantity into an electrical signal. They are used in a wide range of applications, including scientific research, industrial process control, and medical diagnosis.

Sensors and transducers are used to convert a physical quantity into an electrical signal. They are used in a wide range of applications, including scientific research, industrial process control, and medical diagnosis.

Sensors and transducers are used to convert a physical quantity into an electrical signal. They are used in a wide range of applications, including scientific research, industrial process control, and medical diagnosis.

Sensors and transducers are used to convert a physical quantity into an electrical signal. They are used in a wide range of applications, including scientific research, industrial process control, and medical diagnosis.

Sensors and transducers are used to convert a physical quantity into an electrical signal. They are used in a wide range of applications, including scientific research, industrial process control, and medical diagnosis.

Sensors and transducers are used to convert a physical quantity into an electrical signal. They are used in a wide range of applications, including scientific research, industrial process control, and medical diagnosis.

Sensors and transducers are used to convert a physical quantity into an electrical signal. They are used in a wide range of applications, including scientific research, industrial process control, and medical diagnosis.

Sensors and transducers are used to convert a physical quantity into an electrical signal. They are used in a wide range of applications, including scientific research, industrial process control, and medical diagnosis.

Sensors and transducers are used to convert a physical quantity into an electrical signal. They are used in a wide range of applications, including scientific research, industrial process control, and medical diagnosis.

Sensors and transducers are used to convert a physical quantity into an electrical signal. They are used in a wide range of applications, including scientific research, industrial process control, and medical diagnosis.

Sensors and transducers are used to convert a physical quantity into an electrical signal. They are used in a wide range of applications, including scientific research, industrial process control, and medical diagnosis.

Sensors and transducers are used to convert a physical quantity into an electrical signal. They are used in a wide range of applications, including scientific research, industrial process control, and medical diagnosis.

Sensors and transducers are used to convert a physical quantity into an electrical signal. They are used in a wide range of applications, including scientific research, industrial process control, and medical diagnosis.

Sensors and transducers are used to convert a physical quantity into an electrical signal. They are used in a wide range of applications, including scientific research, industrial process control, and medical diagnosis.

Sensors and transducers are used to convert a physical quantity into an electrical signal. They are used in a wide range of applications, including scientific research, industrial process control, and medical diagnosis.

Sensors and transducers are used to convert a physical quantity into an electrical signal. They are used in a wide range of applications, including scientific research, industrial process control, and medical diagnosis.

Sensors and transducers are used to convert a physical quantity into an electrical signal. They are used in a wide range of applications, including scientific research, industrial process control, and medical diagnosis.

Sensors and transducers are used to convert a physical quantity into an electrical signal. They are used in a wide range of applications, including scientific research, industrial process control, and medical diagnosis.

Sensors and transducers are used to convert a physical quantity into an electrical signal. They are used in a wide range of applications, including scientific research, industrial process control, and medical diagnosis.

Sensors and transducers are used to convert a physical quantity into an electrical signal. They are used in a wide range of applications, including scientific research, industrial process control, and medical diagnosis.

Sensors and transducers are used to convert a physical quantity into an electrical signal. They are used in a wide range of applications, including scientific research, industrial process control, and medical diagnosis.

Sensors and transducers are used to convert a physical quantity into an electrical signal. They are used in a wide range of applications, including scientific research, industrial process control, and medical diagnosis.

Sensors and transducers are used to convert a physical quantity into an electrical signal. They are used in a wide range of applications, including scientific research, industrial process control, and medical diagnosis.

Sensors and transducers are used to convert a physical quantity into an electrical signal. They are used in a wide range of applications, including scientific research, industrial process control, and medical diagnosis.

Sensors and transducers are used to convert a physical quantity into an electrical signal. They are used in a wide range of applications, including scientific research, industrial process control, and medical diagnosis.

Sensors and transducers are used to convert a physical quantity into an electrical signal. They are used in a wide range of applications, including scientific research, industrial process control, and medical diagnosis.

Sensors and transducers are used to convert a physical quantity into an electrical signal. They are used in a wide range of applications, including scientific research, industrial process control, and medical diagnosis.

Sensors and transducers are used to convert a physical quantity into an electrical signal. They are used in a wide range of applications, including scientific research, industrial process control, and medical diagnosis.

Illustrations and Diagrams

Over 400 illustrations help clarify the concepts, with real-life photographs to augment schematic diagrams wherever necessary.

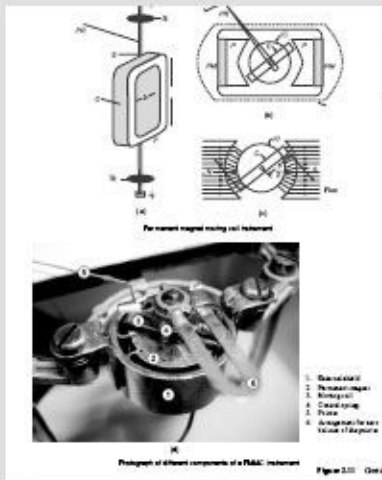

Figure 2.10 (cont.)

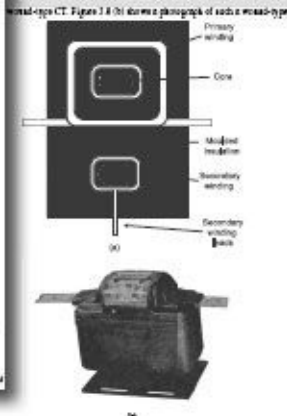

Figure 2.9 (a) Cross-section of wound-type CT (b) Photograph of wound-type CT (Courtesy of General Electric Company)

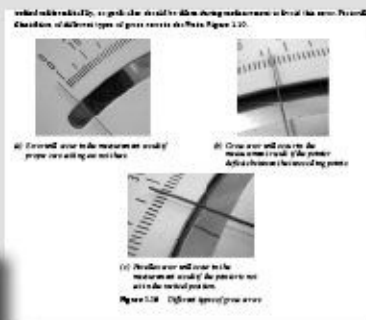

Figure 2.8 Different types of gas errors

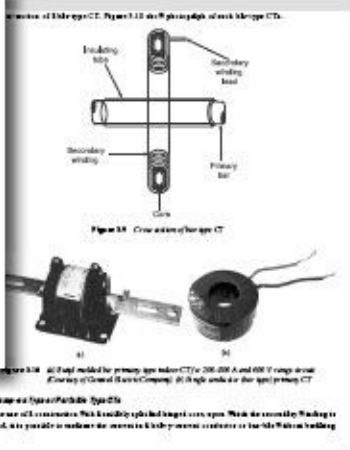

Figure 2.12 (a) Photograph of bar-type CT (b) Photograph of bar-type CT (Courtesy of General Electric Company)

2. Can you give an example of a permanent magnet moving coil instrument?

Example 2.1 The coil of a PMMC instrument has 40 turns and former diameter 10 mm. The length of the conductor being 20 mm. It moves in a uniform field of flux density 0.2 T. The control spring constant is 12×10^{-6} Nm/rad. Calculate the current required to produce deflection of 120 degrees.

Solve: Total deflection angle $\theta = 120^\circ$

$$T_p = B I N A \sin \theta$$

$$= 0.2 \times I \times 40 \times 10^{-6} \times 40 \times 10^{-6} \times 120 \times \frac{\pi}{180}$$

The control spring $T_c = \theta \times C$

$$= 120 \times 12 \times 10^{-6} = 1.44 \times 10^{-3} \text{ Nm}$$

At equilibrium, $T_p = T_c$

$$0.2 \times I \times 40 \times 10^{-6} \times 40 \times 10^{-6} \times 120 \times \frac{\pi}{180} = 1.44 \times 10^{-3}$$

$$I = \frac{1.44 \times 10^{-3} \times 180}{0.2 \times 40 \times 10^{-6} \times 40 \times 10^{-6} \times 120 \times \pi} = 11.21 \text{ mA}$$

Example 2.2 A PMMC instrument has a coil of dimensions 15 mm \times 12 mm. The flux density in the air gap is 1.2×10^{-2} T and the spring constant is 0.24×10^{-6} Nm/rad. Determine the number of turns required to produce an angular deflection of 90° when a current of 10 mA is flowing through it.

Solve: Total deflection angle $\theta = 90^\circ$

$$T_p = B I N A \sin \theta$$

$$= 1.2 \times 10^{-2} \times I \times 10 \times 10^{-2} \times 12 \times 10^{-2} \times 90 \times \frac{\pi}{180}$$

The control spring $T_c = \theta \times C$

$$= 90 \times 0.24 \times 10^{-6} = 2.16 \times 10^{-5} \text{ Nm}$$

At equilibrium, $T_p = T_c$

$$1.2 \times 10^{-2} \times I \times 10 \times 10^{-2} \times 12 \times 10^{-2} \times 90 \times \frac{\pi}{180} = 2.16 \times 10^{-5}$$

$$I = \frac{2.16 \times 10^{-5} \times 180}{1.2 \times 10^{-2} \times 10 \times 10^{-2} \times 12 \times 10^{-2} \times 90 \times \pi} = 1.21 \text{ mA}$$

Example 2.3 A PMMC instrument with resistance of 100 Ω gives a full scale deflection of 100° when a potential difference of 100 mV is applied across it. The moving coil has dimensions of 30 mm \times 20 mm and is wound with 100 turns. The control spring constant is 0.25×10^{-6} Nm/rad. Find the flux density in the air gap. Find also the diameter of copper wire of coil winding if 90% of the wire cross-section is due to coil winding. The specific resistance of copper is 1.7×10^{-8} Ω m.

Solved Examples

About 100 Solved Examples are given in the text which help reinforce the understanding of concepts and illustrate the way the formulae developed can be used for solving problems.

1

Concept of Measurement Systems

1.1

INTRODUCTION

Measurement is the act, or the result, of a quantitative comparison between a given quantity and a quantity of the same kind chosen as a unit. The result of the measurement is expressed by a pointer deflection over a predefined scale or a number representing the ratio between the unknown quantity and the standard. A standard is defined as the physical personification of the unit of measurement or its submultiple or multiple values. The device or instrument used for comparing the unknown quantity with the unit of measurement or a standard quantity is called a *measuring instrument*. The value of the unknown quantity can be measured by direct or indirect methods. In direct measurement methods, the unknown quantity is measured directly instead of comparing it with a standard. Examples of direct measurement are current by ammeter, voltage by voltmeter, resistance by ohmmeter, power by wattmeter, etc. In indirect measurement methods, the value of the unknown quantity is determined by measuring the functionally related quantity and calculating the desired quantity rather than measuring it directly. Suppose the resistance as (R) of a conductor can be measured by measuring the voltage drop across the conductor and dividing the voltage (V) by the current (I) through the conductors, by Ohm's $R = \frac{V}{I}$

1.2

FUNDAMENTAL AND DERIVED UNITS

At the time of measuring a physical quantity, we must express the magnitude of that quantity in terms of a unit and a numerical multiplier, i.e.,

Magnitude of a physical quantity = (Numerical ratio) \times (Unit)

The numerical ratio is the number of times the unit occurs in any given amount of the same quantity and, therefore, is called the *number of measures*. The numerical ratio may be called *numerical multiplier*. However, in measurements, we are concerned with a large number of quantities which are related to each other, through established physical equations, and therefore the choice of size of units of these quantities cannot be done arbitrarily and independently. In this way, we can avoid the use of awkward numerical constants when we express a quantity of one kind which has been derived from measurement of another quantity.

In science and engineering, two kinds of units are used:

- Fundamental units

- Derived units

The *fundamental units* in mechanics are measures of length, mass and time. The sizes of the fundamental units, whether foot or metre, pound or kilogram, second or hour are arbitrary and can be selected to fit a certain set of circumstances. Since length, mass and time are fundamental to most other physical quantities besides those in mechanics, they are called the *primary fundamental units*. Measures of certain physical quantities in the thermal, electrical and illumination disciplines are also represented by fundamental units. These units are used only when these particular classes are involved, and they may therefore be defined as *auxiliary fundamental units*.

All other units which can be expressed in terms of the fundamental units are called *derived units*. Every derived unit originates from some physical law defining that unit. For example, the area (A) of a rectangle is proportional to its length (l) and breadth (b), or $A = lb$. If the metre has been chosen as the unit of length then the area of a rectangle of 5 metres by 7 metres is 35 m². Note that the numbers of measure are multiplied as well as the units. The derived unit for area (A) is then the metre square (m²).

A derived unit is recognized by its dimensions, which can be defined as the complete algebraic formula for the derived unit. The dimensional symbols for the fundamental units of length, mass and time are L, M and T respectively. The dimensional symbol for the derived unit of area is L² and that for volume is L³. The dimensional symbol for the unit of force is MLT⁻², which follows from the defining equation for force. The dimensional formulas of the derived units are particularly useful for converting units from one system to another. For convenience, some derived units have been given new names. For example, the derived unit of force in the SI system is called the newton (N), instead of the dimensionally correct kg-m/s².

1.3

STANDARDS AND THEIR CLASSIFICATIONS

A standard of measurement is a physical representation of a unit of measurement. A unit is realised by reference to an arbitrary material standard or to natural phenomena including physical and atomic constants. The term 'standard' is applied to a piece of equipment having a known measure of physical quantity. For example, the fundamental unit of mass in the SI system is the kilogram, defined as the mass of the cubic decimetre of water at its temperature of maximum of 4°C. This unit of mass is represented by a material standard; the mass of the international prototype kilogram consisting of a platinum–iridium hollow cylinder. This unit is preserved at the International Bureau of Weights and Measures at Sevres, near Paris, and is the material representation of the kilogram. Similar standards have been developed for other units of measurement, including fundamental units as well as for some of the derived mechanical and electrical units.

The classifications of standards are

1. International standards
2. Primary standards

3. Secondary standards
4. Working standards
5. Current standards
6. Voltage standards
7. Resistance standards
8. Capacitance standards
9. Time and frequency standards

1.3.1 International Standards

The international standards are defined by international agreement. They represent certain units of measurement to the closest possible accuracy that production and measurement technology allow. International standards are periodically checked and evaluated by absolute measurements in terms of the fundamental units. These standards are maintained at the International Bureau of Weights and Measures and are not available to the ordinary user of measuring instruments for purposes of comparison or calibration. [Table 1.1](#) shows basic SI Units, Quantities and Symbols.

Table 1.1 *Basic Quantities, SI Units and Symbols*

Quantity	Unit	Symbol
Length	Meter	m
Mass	Kilogram	kg
Time	Second	s
Luminous Intensity	Candela	cd
Thermodynamic temperature	Kelvin	K
Electric current	Ampere	A

1.3.2 Primary Standards

The primary standards are maintained by national standards laboratories in different places of the world. The National Bureau of Standards (NBS) in Washington is responsible for maintenance of the primary standards in North America. Other national laboratories include the National Physical Laboratory (NPL) in Great Britain and the oldest in the world, the Physikalisch Technische Reichsanstalt in Germany. The primary standards, again representing the fundamental units and some of the derived mechanical and electrical units, are independently calibrated by absolute measurements at each of the national laboratories. The results of these measurements are compared with each other, leading to a world average figure for the primary standard. Primary standards are not available for use outside the national laboratories. One of the main functions of primary standards is the verification and calibration of secondary standards.

1.3.3 Secondary Standards

Secondary standards are the basic reference standards used in the industrial measurement laboratories. These standards are maintained by the particular involved industry and are

checked locally against other reference standards in the area. The responsibility for maintenance and calibration rests entirely with the industrial laboratory itself. Secondary standards are generally sent to the national standards laboratory on a periodic basis for calibration and comparison against the primary standards. They are then returned to the industrial user with a certification of their measured value in terms of the primary standard.

1.3.4 Working Standards

Working standards are the principle tools of a measurement laboratory. They are used to check and calibrate general laboratory instruments for accuracy and performance or to perform comparison measurements in industrial applications. A manufacturer of precision resistances, for example, may use a standard resistor in the quality control department of his plant to check his testing equipment. In this case, the manufacturer verifies that his measurement setup performs within the required limits of accuracy.

1.3.5 Current Standard

The fundamental unit of electric current (Ampere) is defined by the International System of Units (SI) as the constant current which, if maintained in two straight parallel conductors of infinite length and negligible circular cross section placed 1 meter apart in vacuum, will produce between these conductors a force equal to 2×10^{-7} newton per meter length. Early measurements of the absolute value of the ampere were made with a current balance which measured the force between two parallel conductors. These measurements were rather crude and the need was felt to produce a more practical and reproducible standard for the national laboratories. By international agreement, the value of the international ampere was based on the electrolytic deposition of silver from a silver nitrate solution. The *international ampere* was then defined as that current which deposits silver at the rate of 1.118 mg/s from a standard silver nitrate solution. Difficulties were encountered in the exact measurement of the deposited silver and slight discrepancies existed between measurements made independently by the various National Standard Laboratories. Later, the international ampere was superseded by the *absolute ampere* and it is now the fundamental unit of electric current in the SI and is universally accepted by international agreement.

1.3.6 Voltage Standard

In early times, the standard volt was based on an electrochemical cell called the *saturated standard cell* or simply *standard cell*. The saturated cell has temperature dependence, and the output voltage changes about $-40 \mu\text{V}/^\circ\text{C}$ from the nominal of 1.01858 volt. The standard cell suffers from this temperature dependence and also from the fact that the voltage is a function of a chemical reaction and not related directly to any other physical constants. In 1962, based on the work of Brian Josephson, a new standard for the volt was introduced. A thin-film junction is cooled to nearly absolute zero and irradiated with microwave energy. A voltage is developed across the junction, which is related to the irradiating frequency by the following relationship:

$$v = \frac{hf}{2e}$$

where, h = Planck's constant = 6.63×10^{-34} J-s

e = charge of an electron = 1.602×10^{-19} C

f = frequency of the microwave irradiation

In Eq. (1.1), the irradiation frequency is the only variable, thus the standard volt is related to the standard of time/frequency. When the microwave irradiating frequency is locked to an atomic clock or a broadcast frequency standard such as WWVB, the accuracy of the standard volt, including all of the system inaccuracies, is one part in 10^8 .

The major method of transferring the volt from the standard based on the Josephson junction to secondary standards used for calibration of the standard cell. This device is called the normal or saturated Weston cell. The Weston cell has a positive electrode of mercury and a negative electrode of cadmium amalgam (10% cadmium). The electrolyte is a solution of cadmium sulfate. These components are placed in an H-shaped glass container as shown in [Figure 1.1](#).



Figure 1.1 Standard cell of emf of 1.0183 volt at 20°C (Courtesy, physics.kenyon.edu)

1.3.7 Resistance Standard

In the SI system, the absolute value of ohm is defined in terms of the fundamental units of length, mass and time. The absolute measurement of the ohm is carried out by the International Bureau of Weights and Measures in Sevres and also by the national standard laboratories, which preserve a group of primary resistance standards. The NBS maintains a group of those primary standards (1 ohm standard resistors) which are periodically checked against each other and are occasionally verified by absolute measurements. The standard resistor is a coil of wire of some alloy like manganin which has a high electrical resistivity and a low temperature coefficient of resistance. The resistance coil is mounted in a double walled sealed container as shown in [Figure 1.2](#) to prevent changes in

resistance due to moisture conditions in the atmosphere. With a set of four or five 1-ohm resistors in this type, the unit resistance can be represented with a precision of a few parts in 10^7 over several years.

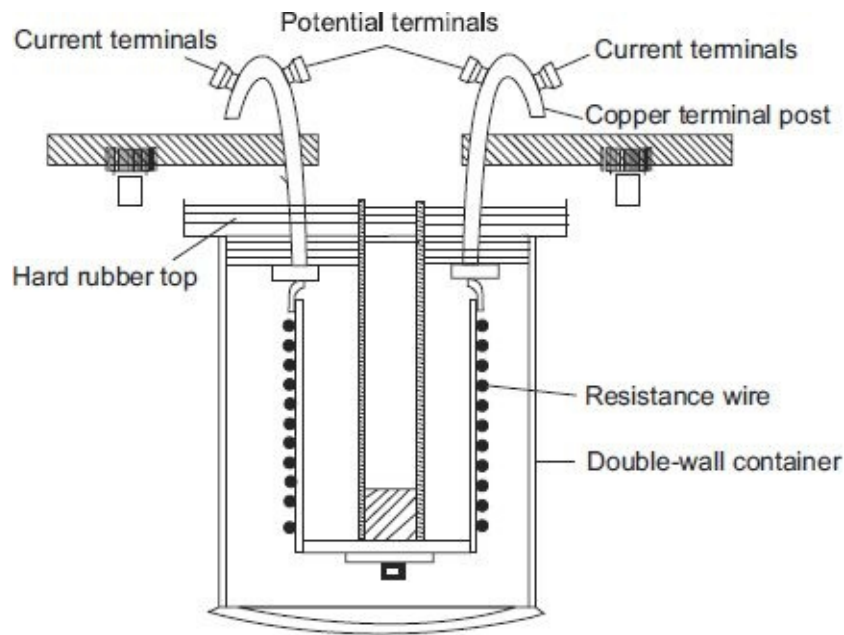

Figure 1.2 Resistance standard

Secondary standards and working standards are available from some instrument manufactures in a wide range of values, usually in multiples of 10 ohms. These standard resistors are sometimes called *transfer resistor* and are made of alloy resistance wire, such as manganin or Evanohm. The resistance coil of the transfer resistor is supported between polyester films to reduce stresses on the wire and to improve the stability of the resistor. The coil is immersed in moisture free oil and placed in a sealed container. The connections to the coil are silver soldered, and the terminal hooks are made of nickel-plated oxygen free copper. The transfer resistor is checked for stability and temperature characteristics at its rated power and a specified operating temperature (usually 25°C). A calibration report accompanying the resistor specifies its traceability to NBS standards and includes the α and β temperature coefficients. Although the selected resistance wire provides almost constant resistance over a fairly wide temperature range, the exact value of the resistance at any temperature can be calculated from the formula

$$R_t = R_{25^\circ\text{C}} + \alpha(t - 25) + \beta(t - 25)^2$$

where R_t = resistance at the ambient temperature t

$R_{25^\circ\text{C}}$ = resistance at 25°C

α, β = temperature coefficients

Temperature coefficient α is usually less than 10×10^{-7} , and coefficient β lies between -3×10^{-7} to -6×10^{-7} . This means that a change in temperature of 10°C from the specified reference temperature of 25°C may cause a change in resistance of 30 to 60 ppm from the nominal value.

1.3.8 Capacitance Standard

Many electrical and magnetic units may be expressed in terms of these voltage and

resistance standards since the unit of resistance is represented by the standard resistor and the unit of voltage by standard Weston cell. The unit of capacitance (the farad) can be measured with a Maxwell dc commutated bridge, where the capacitance is computed from the resistive bridge arms and the frequency of the dc commutation. The bridge is shown in [Figure 1.3](#). Capacitor C is alternately charged and discharged through the commutating contact and resistor R . Bridge balance is obtained by adjusting the resistance R_3 , allowing exact determination of the capacitance value in terms of the bridge arm constants and frequency of commutation. Although the exact derivation of the expression for capacitance in terms of the resistances and the frequency is rather involved, it may be seen that the capacitor could be measured accurately by this method. Since both resistance and frequency can be determined very accurately, the value of the capacitance can be measured with great accuracy. Standard capacitors are usually constructed from interleaved metal plates with air as the dielectric material. The area of the plates and the distance between them must be known very accurately, and the capacitance of the air capacitor can be determined from these basic dimensions. The NBS maintains a bank of air capacitors as standards and uses them to calibrate the secondary and working standards of measurement laboratories and industrial users.

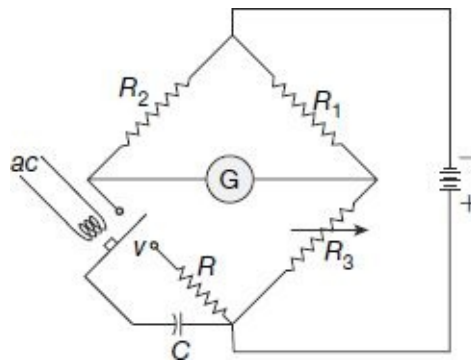

Figure 1.3 *Commutated dc method for measuring capacitance*

1.3.9 Time Standard and Frequency Standard

In early centuries the time reference used was the rotation of the earth around the sun about its axis. Later, precise astronomical observations have shown that the rotation of the earth around the sun is very irregular, owing to secular and irregular variations in the rotational speed of the earth. So the time scale based on this apparent solar time had to be changed. *Mean solar time* was thought to give a more accurate time scale. A *mean solar day* is the average of all the apparent days in the year. A *mean solar second* is then equal to 1/86400 of the mean solar day. The mean solar second is still inappropriate since it is based on the rotation of the earth which is non-uniform.

In the year 1956, the *ephemeris second* has been defined by the International Bureau of Weights and Measures as the fraction 1/31556925.99747 of the tropical year for 1900 January 01 at 12 h ET (Ephemeris Time), and adopted as the fundamental invariable unit of time. A disadvantage of the use of the *ephemeris* second is that it can be determined only several years in arrears and then only indirectly, by observations of the positions of the sun and the moon. For physical measurements, the unit of time interval has now been defined in terms of an atomic standard. The universal second and the *ephemeris* second, however, will continue to be used for navigation, geodetic surveys and celestial mechanics. The atomic units of the time was first related to UT (Universal Time) but was

later expressed in terms of ET. The International Committee of Weights and Measures has now defined the second in terms of frequency of the cesium transition, assigning a value of 9192631770 Hz to the hyperfine transition of the cesium atom unperturbed by external fields.

The atomic definition of second realises an accuracy much greater than that achieved by astronomical observations, resulting in a more uniform and much more convenient time base. Determinations of time intervals can now be made in a few minutes to greater accuracy than was possible before in astronomical measurements that took many years to complete. An atomic clock with a precision exceeding 1 μ s per day is in operation as a primary frequency standard at the NBS. An atomic time scale, designated NBS-A, is maintained with this clock.

Time and frequency standards are unique in that they may be transmitted from the primary standard at NBS to other locations via radio or television transmission. Early standard time and frequency transmission were in the High Frequency (HF) portion of the radio spectrum, but these transmissions suffered from Doppler shifts due to the fact that radio propagation was primarily ionospheric. Transmission of time and frequency standards via low frequency and very low frequency radio reduces this Doppler shift because the propagation is strictly ground wave. Two NBS operated stations, WWVL and WWVB, operate 20 and 60 kHz, respectively, providing precision time and frequency transmissions.

1.4

METHODS OF MEASUREMENT

As discussed above, the measurement methods can be classified as

- Direct comparison methods
- Indirect comparison methods

1.4.1 Direct Comparison Methods

In direct measurement methods, the unknown quantity is measured directly. Direct methods of measurement are of two types, namely, *deflection methods* and *comparison methods*.

In deflection methods, the value of the unknown quantity is measured by the help of a measuring instrument having a calibrated scale indicating the quantity under measurement directly, such as measurement of current by an ammeter.

In comparison methods, the value of the unknown quantity is determined by direct comparison with a standard of the given quantity, such as measurement of emf by comparison with the emf of a standard cell. Comparison methods can be classified as null methods, differential methods, etc. In null methods of measurement, the action of the unknown quantity upon the instrument is reduced to zero by the counter action of a known quantity of the same kind, such as measurement of weight by a balance, measurement of resistance, capacitance, and inductance by bridge circuits.

1.4.2 Indirect Comparison Methods

In indirect measurement methods, the comparison is done with a standard through the use of a calibrated system. These methods for measurement are used in those cases where the desired parameter to be measured is difficult to be measured directly, but the parameter has got some relation with some other related parameter which can be easily measured.

For instance, the elimination of bacteria from some fluid is directly dependent upon its temperature. Thus, the bacteria elimination can be measured indirectly by measuring the temperature of the fluid.

In indirect methods of measurement, it is general practice to establish an empirical relation between the actual measured quantity and the desired parameter.

The different methods of measurement are summarised with the help of a tree diagram in [Figure 1.4](#).

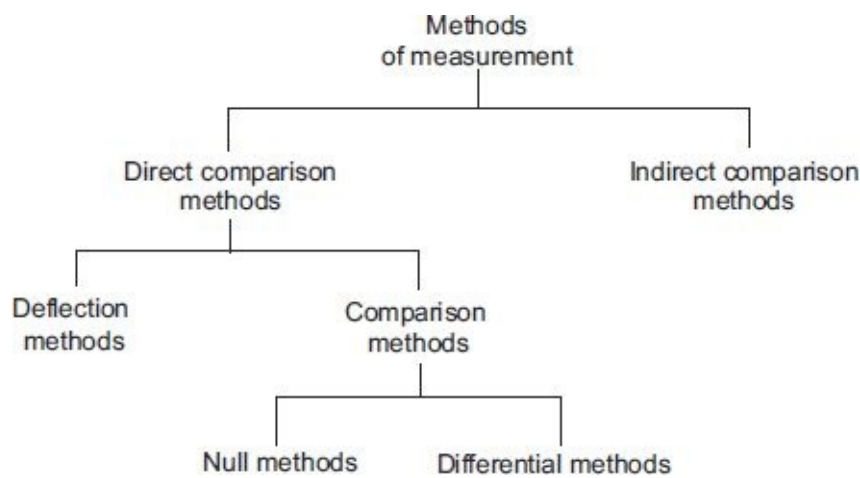

Figure 1.4 Different methods of measurement

1.5

MEASUREMENT SYSTEM AND ITS ELEMENTS

A measurement system may be defined as a systematic arrangement for the measurement or determination of an unknown quantity and analysis of instrumentation. The generalised measurement system and its different components/elements are shown in [Figure 1.5](#).

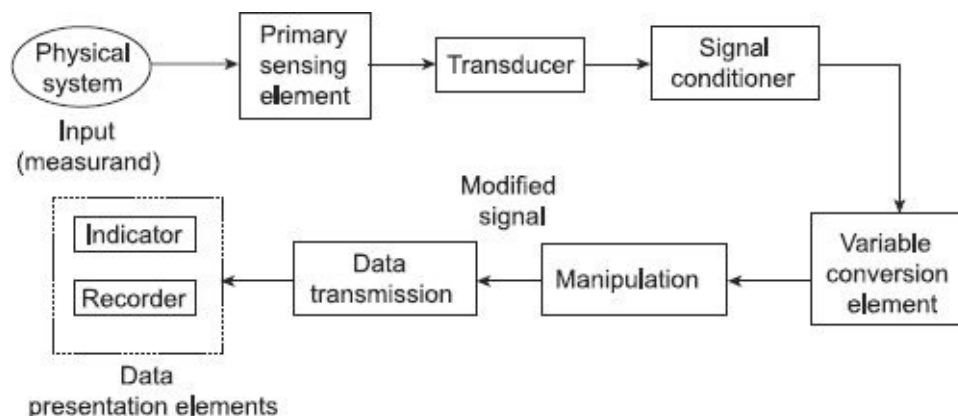

Figure 1.5 Generalised measurement system

The operation of a measurement system can be explained in terms of functional

elements of the system. Every instrument and measurement system is composed of one or more of these functional elements and each functional element is made of distinct components or groups of components which performs required and definite steps in measurement. The various elements are the following:

1.5.1 Primary Sensing Elements

It is an element that is sensitive to the measured variable. The physical quantity under measurement, called the *measurand*, makes its first contact with the primary sensing element of a measurement system. The measurand is always disturbed by the act of the measurement, but good instruments are designed to minimise this effect. Primary sensing elements may have a non-electrical input and output such as a spring, manometer or may have an electrical input and output such as a rectifier. In case the primary sensing element has a non-electrical input and output, then it is converted into an electrical signal by means of a transducer. The transducer is defined as a device, which when actuated by one form of energy, is capable of converting it into another form of energy.

Many a times, certain operations are to be performed on the signal before its further transmission so that interfering sources are removed in order that the signal may not get distorted. The process may be linear such as amplification, attenuation, integration, differentiation, addition and subtraction or nonlinear such as modulation, detection, sampling, filtering, chopping and clipping, etc. The process is called signal conditioning. So a signal conditioner follows the primary sensing element or transducer, as the case may be. The sensing element senses the condition, state or value of the process variable by extracting a small part of energy from the measurand, and then produces an output which reflects this condition, state or value of the measurand.

1.5.2 Variable Conversion Elements

After passing through the primary sensing element, the output is in the form of an electrical signal, may be voltage, current, frequency, which may or may not be accepted to the system. For performing the desired operation, it may be necessary to convert this output to some other suitable form while retaining the information content of the original signal. For example, if the output is in analog form and the next step of the system accepts only in digital form then an analog-to-digital converter will be employed. Many instruments do not require any variable conversion unit, while some others require more than one element.

1.5.3 Manipulation Elements

Sometimes it is necessary to change the signal level without changing the information contained in it for the acceptance of the instrument. The function of the variable manipulation unit is to manipulate the signal presented to it while preserving the original nature of the signal. For example, an electronic amplifier converts a small low voltage input signal into a high voltage output signal. Thus, the voltage amplifier acts as a variable manipulation unit. Some of the instruments may require this function or some of the instruments may not.

1.5.4 Data Transmission Elements

The data transmission elements are required to transmit the data containing the information of the signal from one system to another. For example, satellites are physically separated from the earth where the control stations guiding their movement are located.

1.5.5 Data Presentation Elements

The function of the data presentation elements is to provide an indication or recording in a form that can be evaluated by an unaided human sense or by a controller. The information regarding measurand (quantity to be measured) is to be conveyed to the personnel handling the instrument or the system for monitoring, controlling or analysis purpose. Such a device may be in the form of analog or digital format. The simplest form of a display device is the common panel meter with some kind of calibrated scale and pointer. In case the data is to be recorded, recorders like magnetic tapes or magnetic discs may be used. For control and analysis purpose, computers may be used.

The stages of a typical measurement system are summarised below with the help of a flow diagram in [Figure 1.6](#).

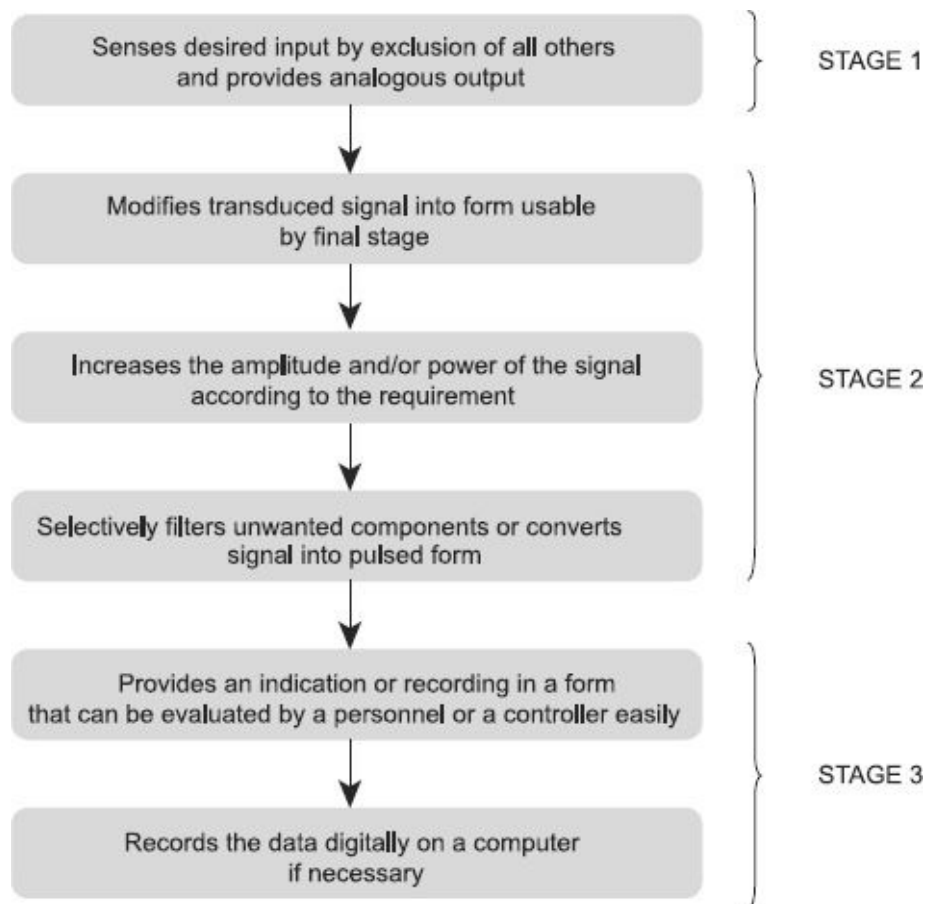

Figure 1.6 Steps of a typical measurement system

1.6

CLASSIFICATION OF INSTRUMENTS

The measuring instruments may be classified as follows:

1.6.1 Absolute and Secondary Instruments

1. Absolute Instruments

The instruments of this type give the value of the measurand in terms of instrument constant and its deflection. Such instruments do not require comparison with any other standard. The example of this type of instrument is tangent galvanometer, which gives the value of the current to be measured in terms of tangent of the angle of deflection produced, the horizontal component of the earth's magnetic field, the radius and the number of turns of the wire used. Rayleigh current balance and absolute electrometer are other examples of absolute instruments. Absolute instruments are mostly used in standard laboratories and in similar institutions as standardising. The classification of measuring instruments is shown in [Figure 1.7](#).

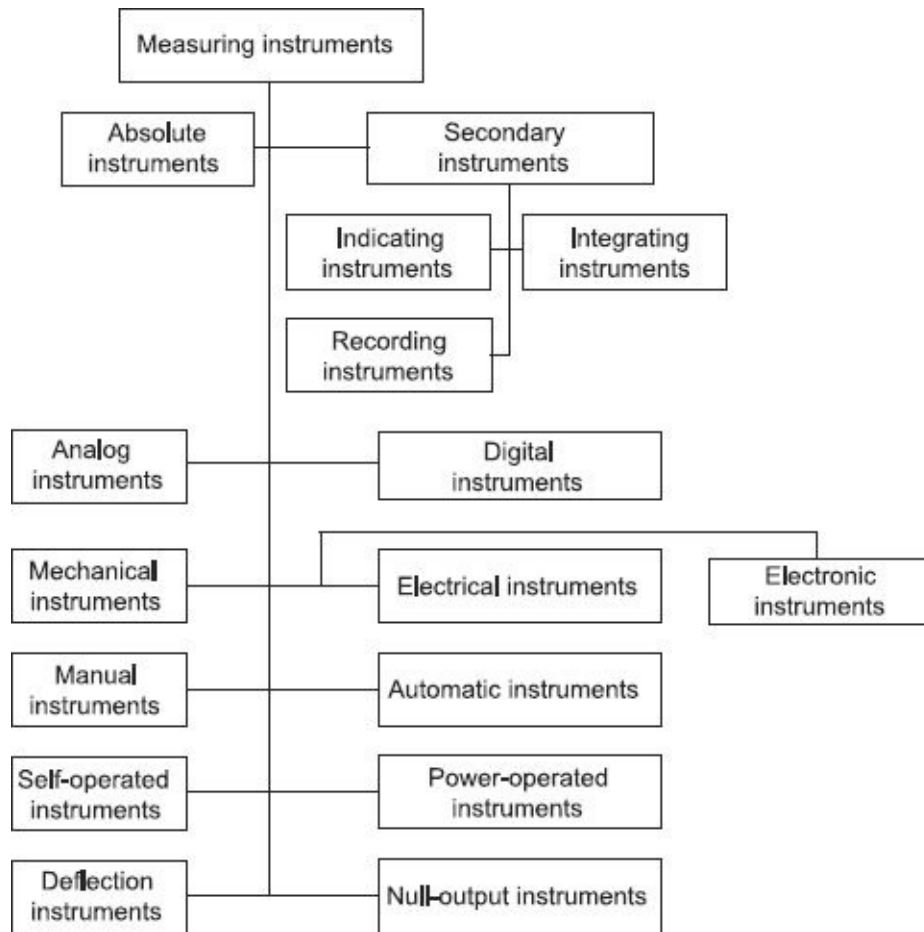

Figure 1.7 Classification of measuring instruments

2. Secondary Instruments

These instruments are so constructed that the deflection of such instruments gives the magnitude of the electrical quantity to be measured directly. These instruments are required to be calibrated by comparison with either an absolute instrument or with another secondary instrument, which has already been calibrated before the use. These instruments are generally used in practice.

Secondary instruments are further classified as

- Indicating instruments
- Integrating instruments

- Recording instruments

(i) Indicating Instruments

Indicating instruments are those which indicate the magnitude of an electrical quantity at the time when it is being measured. The indications are given by a pointer moving over a calibrated (pregraduated) scale. Ordinary ammeters, voltmeters, wattmeters, frequency meters, power factor meters, etc., fall into this category.

(ii) Integrating Instruments

Integrating instruments are those which measure the total amount of either quantity of electricity (ampere-hours) or electrical energy supplied over a period of time. The summation, given by such an instrument, is the product of time and an electrical quantity under measurement. The ampere-hour meters and energy meters fall in this class.

(iii) Recording Instruments

Recording instruments are those which keep a continuous record of the variation of the magnitude of an electrical quantity to be observed over a definite period of time. In such instruments, the moving system carries an inked pen which touches lightly a sheet of paper wrapped over a drum moving with uniform slow motion in a direction perpendicular to that of the direction of the pointer. Thus, a curve is traced which shows the variations in the magnitude of the electrical quantity under observation over a definite period of time. Such instruments are generally used in powerhouses where the current, voltage, power, etc., are to be maintained within certain acceptable limit.

1.6.2 Analog and Digital Instruments

1. Analog Instruments

The signals of an analog unit vary in a continuous fashion and can take on infinite number of values in a given range. Fuel gauge, ammeter and voltmeters, wrist watch, speedometer fall in this category.

2. Digital Instruments

Signals varying in discrete steps and taking on a finite number of different values in a given range are digital signals and the corresponding instruments are of digital type. Digital instruments have some advantages over analog meters, in that they have high accuracy and high speed of operation. It eliminates the human operational errors. Digital instruments can store the result for future purposes. A digital multimeter is the example of a digital instrument.

1.6.3 Mechanical, Electrical and Electronics Instruments

1. Mechanical Instruments

Mechanical instruments are very reliable for static and stable conditions. They are unable to respond rapidly to the measurement of dynamic and transient conditions due to the fact that they have moving parts that are rigid, heavy and bulky and consequently have a large

mass. Mass presents inertia problems and hence these instruments cannot faithfully follow the rapid changes which are involved in dynamic instruments. Also, most of the mechanical instruments causes noise pollution.

Advantages of Mechanical Instruments

- Relatively cheaper in cost
- More durable due to rugged construction
- Simple in design and easy to use
- No external power supply required for operation
- Reliable and accurate for measurement of stable and time invariant quantity

Disadvantages of Mechanical Instruments

- Poor frequency response to transient and dynamic measurements
- Large force required to overcome mechanical friction
- Incompatible when remote indication and control needed
- Cause noise pollution

2. Electrical Instruments

When the instrument pointer deflection is caused by the action of some electrical methods then it is called an electrical instrument. The time of operation of an electrical instrument is more rapid than that of a mechanical instrument. Unfortunately, an electrical system normally depends upon a mechanical measurement as an indicating device. This mechanical movement has some inertia due to which the frequency response of these instruments is poor.

3. Electronic Instruments

Electronic instruments use semiconductor devices. Most of the scientific and industrial instrumentations require very fast responses. Such requirements cannot be met with by mechanical and electrical instruments. In electronic devices, since the only movement involved is that of electrons, the response time is extremely small owing to very small inertia of the electrons. With the use of electronic devices, a very weak signal can be detected by using pre-amplifiers and amplifiers.

Advantages of Electrical/Electronic Instruments

- Non-contact measurements are possible
- These instruments consume less power
- Compact in size and more reliable in operation
- Greater flexibility
- Good frequency and transient response
- Remote indication and recording possible

- Amplification produced greater than that produced in mechanical instruments

1.6.4 Manual and Automatic Instruments

In case of manual instruments, the service of an operator is required. For example, measurement of temperature by a resistance thermometer incorporating a Wheatstone bridge in its circuit, an operator is required to indicate the temperature being measured.

In an automatic type of instrument, no operator is required all the time. For example, measurement of temperature by mercury-in-glass thermometer.

1.6.5 Self-operated and Power-operated Instruments

Self-operated instruments are those in which no outside power is required for operation. The output energy is supplied wholly or almost wholly by the input measurand. Dial-indicating type instruments belong to this category.

The power-operated instruments are those in which some external power such as electricity, compressed air, hydraulic supply is required for operation. In such cases, the input signal supplies only an insignificant portion of the output power. Electromechanical instruments shown in [Figure 1.8](#) fall in this category.

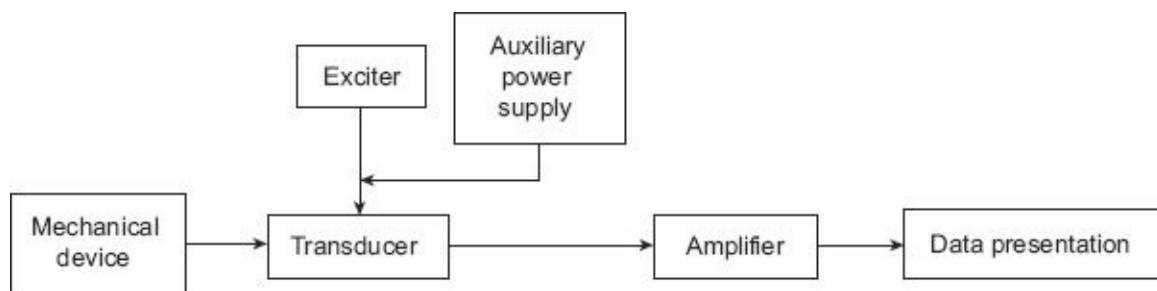

Figure 1.8 *Electromechanical measurement system*

1.6.6 Deflection and Null Output Instruments

In a deflection-type instrument, the deflection of the instrument indicates the measurement of the unknown quantity. The measurand quantity produces some physical effect which deflects or produces a mechanical displacement in the moving system of the instrument. An opposite effect is built in the instrument which opposes the deflection or the mechanical displacement of the moving system. The balance is achieved when opposing effect equals the actuating cause producing the deflection or the mechanical displacement. The deflection or the mechanical displacement at this point gives the value of the unknown input quantity. These type of instruments are suited for measurement under dynamic condition. Permanent Magnet Moving Coil (PMMC), Moving Iron (MI), etc., type instruments are examples of this category.

In null-type instruments, a zero or null indication leads to determination of the magnitude of the measurand quantity. The null condition depends upon some other known conditions. These are more accurate and highly sensitive as compared to deflection-type instruments. A dc potentiometer is a null-type instrument.

1. Accuracy

Accuracy is the closeness with which the instrument reading approaches the true value of the variable under measurement. Accuracy is determined as the maximum amount by which the result differs from the true value. It is almost impossible to determine experimentally the true value. The true value is not indicated by any measurement system due to the loading effect, lags and mechanical problems (e.g., wear, hysteresis, noise, etc.).

Accuracy of the measured signal depends upon the following factors:

- Intrinsic accuracy of the instrument itself;
- Accuracy of the observer;
- Variation of the signal to be measured; and
- Whether or not the quantity is being truly impressed upon the instrument.

2. Precision

Precision is a measure of the reproducibility of the measurements, i.e., precision is a measure of the degree to which successive measurements differ from one another. Precision is indicated from the number of significant figures in which it is expressed. Significant figures actually convey the information regarding the magnitude and the measurement precision of a quantity. More significant figures imply greater precision of the measurement.

3. Resolution

If the input is slowly increased from some arbitrary value it will be noticed that the output does not change at all until the increment exceeds a certain value called the resolution or discrimination of the instrument. Thus, the resolution or discrimination of any instrument is the smallest change in the input signal (quantity under measurement) which can be detected by the instrument. It may be expressed as an accrual value or as a fraction or percentage of the full scale value. Resolution is sometimes referred as *sensitivity*. The largest change of input quantity for which there is no output of the instrument is called the *dead zone* of that instrument.

The sensitivity gives the relation between the input signal to an instrument or a part of the instrument system and the output. Thus, the sensitivity is defined as the ratio of output signal or response of the instrument to a change of input signal or the quantity under measurement.

Example 1.1

A moving coil ammeter has a uniform scale with 50 divisions and gives a full-scale reading of 5 A. The instrument can read up to V th of a scale division with a fair degree of certainty. Determine the resolution of the instrument in mA.

Solution Full-scale reading = 5 A

Number of divisions on scale = 50

$$1 \text{ scale division} = \frac{5}{50} \times 1000 = 100 \text{ mA}$$

$$\text{Resolution} = \frac{1}{4} \text{ th of a scale division} = \frac{100}{4} = 25 \text{ mA}$$

4. Speed of Response

The quickness of an instrument to read the measurand variable is called the speed of response. Alternately, speed of response is defined as the time elapsed between the start of the measurement to the reading taken. This time depends upon the mechanical moving system, friction, etc.

1.8

MEASUREMENT OF ERRORS

In practice, it is impossible to measure the exact value of the measurand. There is always some difference between the measured value and the absolute or true value of the unknown quantity (measurand), which may be very small or may be large. The difference between the true or exact value and the measured value of the unknown quantity is known as the absolute error of the measurement.

If δA be the absolute error of the measurement, A_m and A be the measured and absolute value of the unknown quantity then δA may be expressed as

$$\delta A = A_m - A \quad (1.2)$$

Sometimes, δA is denoted by ϵ_0 .

The relative error is the ratio of absolute error to the true value of the unknown quantity to be measured,

$$\text{i.e., relative error, } \epsilon_r = \frac{\delta A}{A} = \frac{\epsilon_0}{A} = \frac{\text{Absolute error}}{\text{True value}} \quad (1.3)$$

When the absolute error ϵ_0 ($=\delta A$) is negligible, i.e., when the difference between the true value A and the measured value A_m of the unknown quantity is very small or negligible then the relative error may be expressed as,

$$\epsilon_r = \frac{\delta A}{A_m} = \frac{\epsilon_0}{A_m} \quad (1.4)$$

The relative error is generally expressed as a fraction, i.e., 5 parts in 1000 or in percentage value,

$$\text{i.e., percentage error} = \epsilon_r \times 100 = \frac{\epsilon_0}{A_m} \times 100 \quad (1.5)$$

The measured value of the unknown quantity may be more than or less than the true value of the measurand. So the manufacturers have to specify the deviations from the specified value of a particular quantity in order to enable the purchaser to make proper

selection according to his requirements. The limits of these deviations from specified values are defined as limiting or guarantee errors. The magnitude of a given quantity having a specified magnitude A_m and a maximum or a limiting error $\pm\delta A$ must have a magnitude between the limits

$$A_m - \delta A \text{ and } A_m + \delta A$$

or,

$$A = A_m \pm \delta A \quad (1.6)$$

For example, the measured value of a resistance of 100Ω has a limiting error of $\pm 0.5 \Omega$. Then the true value of the resistance is between the limits 100 ± 0.5 , i.e., 100.5 and 99.5 Ω .

Example 1.2

A 0-25 A ammeter has a guaranteed accuracy of 1 percent of full scale reading. The current measured by this instrument is 10 A. Determine the limiting error in percentage.

Solution The magnitude of limiting error of the instrument from Eq. (1.1),

$$\delta A = \varepsilon_r \times A = 0.01 \times 25 = 0.25 \text{ A}$$

The magnitude of the current being measured is 10 A. The relative error at this current is

$$\varepsilon_r = \frac{\delta A}{A} = \frac{0.25}{10} = 0.025$$

Therefore, the current being measured is between the limit of

$$A = A_m(1 \pm \varepsilon_r) = 10(1 \pm 0.025) = 10 \pm 0.25 \text{ A}$$

$$\text{The limiting error} = \frac{0.25}{10} \times 100 = 2.5\%$$

Example 1.3

The inductance of an inductor is specified as $20 \text{ H} \pm 5$ percent by a manufacturer. Determine the limits of inductance between which it is guaranteed.

Solution

$$\text{Relative error, } \varepsilon_r = \frac{\text{Percentage error}}{100} = \frac{5}{100} = 0.05$$

Limiting value of inductance, $A = A_m \pm \delta A$

$$\begin{aligned}
&= A_m \pm \varepsilon_r A_m = A_m (1 \pm \varepsilon_r) \\
&= 20(1 \pm 0.05) = 20 \pm 1 \text{ H}
\end{aligned}$$

Example 1.4

A 0-250 V voltmeter has a guaranteed accuracy of 2% of full-scale reading. The voltage measured by the voltmeter is 150 volts. Determine the limiting error in percentage.

Solution The magnitude of the limiting error of the instrument,

$$\delta A = \varepsilon_r V = 0.02 \times 250 = 5.0 \text{ V}$$

The magnitude of the voltage being measured is 150 V.

The percentage limiting error at this voltage

$$= \frac{5.0}{150} \times 100\% = 3.33\%$$

Example 1.5

The measurand value of a resistance is 10.25 Ω , whereas its value is 10.22 Ω . Determine the absolute error of the measurement.

Solution

Measurand value $A_m = 10.25 \Omega$

True value $A = 10.22 \Omega$

Absolute error, $\delta A = A_m - A = 10.25 - 10.22 = 0.03 \Omega$

Example 1.6

The measured value of a capacitor is 205.3 μF , whereas its true value is 201.4 μF . Determine the relative error.

Solution

Measured value $A_m = 205.3 \times 10^{-6} \text{ F}$

True value, $A = 201.4 \times 10^{-6} \text{ F}$

Absolute error, $\varepsilon_0 = A_m - A$

$$= 205.3 \times 10^{-6} - 201.4 \times 10^{-6}$$

$$= 3.9 \times 10^{-6} \text{ F}$$

$$= 3.9 \times 10^{-6} \text{ F}$$

$$\text{Relative error, } \varepsilon_r = \frac{\varepsilon_0}{A} = \frac{3.9 \times 10^{-6}}{201.4 \times 10^{-6}} = 0.0194 \text{ or } 1.94\%$$

Example 1.7

A wattmeter reads 25.34 watts. The absolute error in the measurement is -0.11 watt. Determine the true value of power.

Solution

Measured value $A_m = 25.34 \text{ W}$

Absolute error $\delta A = -0.11 \text{ W}$

True value $A = \text{Measured value} - \text{Absolute error}$

$$= 25.34 - (-0.11),$$

$$= 25.45 \text{ W}$$

1.8.1 Types of Errors

The origination of error may be in a variety of ways. They are categorised in three main types.

- Gross error
- Systematic error
- Random error

1. Gross Error

The errors occur because of mistakes in observed readings, or using instruments and in recording and calculating measurement results. These errors usually occur because of human mistakes and these may be of any magnitude and cannot be subjected to mathematical treatment. One common gross error is frequently committed during improper use of the measuring instrument. Any indicating instrument changes conditions to some extent when connected in a complete circuit so that the reading of measurand quantity is altered by the method used. For example, in Figure (1.9)(a) and (b), two possible connections of voltage and current coil of a wattmeter are shown.

In [Figure 1.9\(a\)](#), the connection shown is used when the applied voltage is high and current flowing in the circuit is low, while the connection shown in [Figure 1.9\(b\)](#) is used when the applied voltage is low and current flowing in the circuit is high. If these connections of wattmeter are used in opposite order then an error is liable to enter in wattmeter reading. Another example of this type of error is in the use of a well-calibrated voltmeter for measurement of voltage across a resistance of very high value. The same voltmeter, when connected in a low resistance circuit, may give a more dependable reading because of very high resistance of the voltmeter itself. This shows that the voltmeter has a loading effect on the circuit, which alters the original situation during the measurement.

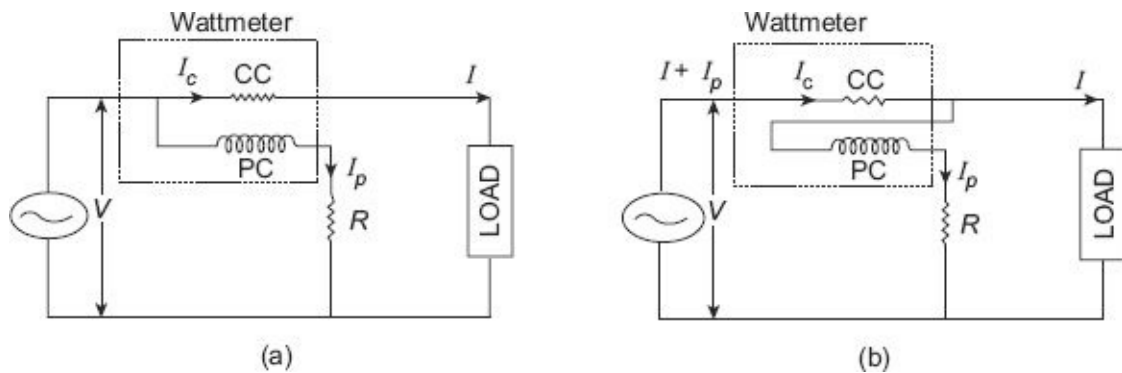
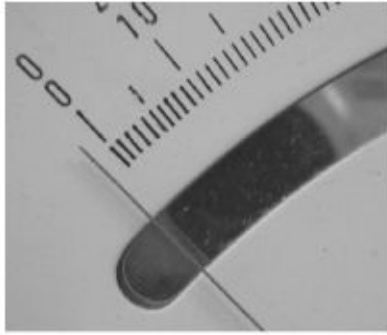
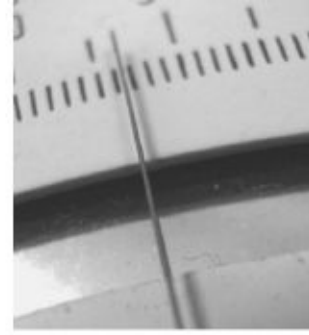

Figure 1.9 Different connections of wattmeter

For another example, a multirange instrument has a different scale for each range. During measurements, the operator may use a scale which does not correspond to the setting of the range selector of the instrument. Gross error may also be there because of improper setting of zero before the measurement and this will affect all the readings taken during measurements. The gross error cannot be treated mathematically, so great care should be taken during measurement to avoid this error. Pictorial illustration of different types of gross error is shown in [Figure 1.10](#).



(a) Error will occur in the measurement result if proper zero setting are not there.



(b) Gross error will occur in the measurement result if the pointer deflects between the two scaling points.

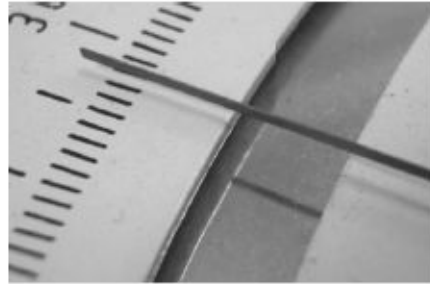

(c) Parallax error will occur in the measurement result if the pointer is not set in the vertical position.

Figure 1.10 Different types of gross errors

In general, to avoid gross error, at least two, three or more readings of the measurand quantity should be taken by different observers. Then if the readings differ by an unacceptably large amount, the situation can be investigated and the more erroneous readings eliminated.

2. Systematic Error

These are the errors that remain constant or change according to a definite law on repeated measurement of the given quantity. These errors can be evaluated and their influence on the results of measurement can be eliminated by the introduction of proper correction. There are two types of systematic errors:

- Instrumental error
- Environmental error

Instrumental errors are inherent in the measuring instruments because of their mechanical structure and calibration or operation of the apparatus used. For example, in D'Arsonval movement, friction in bearings of various components may cause incorrect readings. Improper zero adjustment has a similar effect. Poor construction, irregular spring tensions, variations in the air gap may also cause instrumental errors. Calibration error may also result in the instrument reading either being too low or too high.

Such instrumental errors may be avoided by

- Selecting a proper measuring device for the particular application
- Calibrating the measuring device or instrument against a standard

- Applying correction factors after determining the magnitude of instrumental errors

Environmental errors are much more troublesome as the errors change with time in an unpredictable manner. These errors are introduced due to using an instrument in different conditions than in which it was assembled and calibrated. Change in temperature is the major cause of such errors as temperature affects the properties of materials in different ways, including dimensions, resistivity, spring effect and many more. Other environmental changes also effect the results given by the instruments such as humidity, altitude, earth's magnetic field, gravity, stray electric and magnetic field, etc. These errors can be eliminated or reduced by taking the following precautions:

- Use the measuring instrument in the same atmospheric conditions in which it was assembled and calibrated.
- If the above precaution is not possible then deviation in local conditions must be determined and suitable compensations are applied in the instrumental reading.
- Automatic compensation, employing sophisticated devices for such deviations, is also possible.

3. Random Errors

These errors are of variable magnitude and sign and do not maintain any known law. The presence of random errors become evident when different results are obtained on repeated measurements of one and the same quantity. The effect of random errors is minimised by measuring the given quantity many times under the same conditions and calculating the arithmetical mean of the results obtained. The mean value can justly be considered as the most probable value of the measured quantity since random errors of equal magnitude but opposite sign are of approximately equal occurrence when making a great number of measurements.

1.9

LOADING EFFECTS

Under ideal conditions, an element used for signal sensing, conditioning, transmission and detection should not change/distort the original signal. The sensing element should not use any energy or take least energy from the process so as not to change the parameter being measured. However, under practical conditions, it has been observed that the introduction of any element in a system results invariably in extraction of the energy from the system, thereby distorting the original signal. This distortion may take the form of attenuation, waveform distortion, phase shift, etc., and consequently, the ideal measurements become impossible.

The incapability of the system to faithfully measure the input signal in undistorted form is called *loading effect*. This results in loading error.

The loading effects, in a measurement system, not only occur in the detector–transducer stage but also occur in signal conditioning and signal presentation stages as well. The loading problem is carried right down to the basic elements themselves. The loading effect

may occur on account of both electrical and mechanical elements. These are due to impedances of the various elements connected in a system. The mechanical impedances may be treated similar to electrical impedances.

Sometimes loading effect occurs due to the connection of measuring instruments in an improper way. Suppose a voltmeter is connected with parallel of a very high resistance. Due to the high resistance of the voltmeter itself, the circuit current changes. This is the loading effect of a voltmeter when they are connected in parallel with a very high resistance. Similarly, an ammeter has a very low resistance. So if an ammeter is connected in series with a very low resistance, the total resistance of the circuit changes, and in succession, the circuit current also changes. This is the loading effect of ammeters when they are connected in series with very low resistance.

EXERCISE

Objective-type Questions

1. A null-type instrument as compared to a deflection-type instrument has
 - (a) a lower sensitivity
 - (b) a faster response
 - (c) a higher accuracy
 - (d) all of the above
2. In a measurement system, the function of the signal manipulating element is to
 - (a) change the magnitude of the input signal while retaining its identity
 - (b) change the quantity under measurement to an analogous signal
 - (c) to perform non-linear operation like filtering, chopping and clipping and clamping
 - (d) to perform linear operation like addition and multiplication
3. The measurement of a quantity
 - (a) is an act of comparison of an unknown quantity with a predefined acceptable standard which is accurately known
 - (b) is an act of comparison of an unknown quantity with another quantity
 - (c) is an act of comparison of an unknown quantity with a known quantity whose accuracy may be known or may not be known
 - (d) none of these
4. Purely mechanical instruments cannot be used for dynamic measurements because they have
 - (a) large time constant
 - (b) higher response time
 - (c) high inertia
 - (d) all of the above
5. A modifying input to a measurement system can be defined as an input
 - (a) which changes the input–output relationship for desired as well as interfering inputs
 - (b) which changes the input–output relationship for desired inputs only
 - (c) which changes the input–output relationship for interfering inputs only
 - (d) none of the above
6. In measurement systems, which of the following static characteristics are desirable?

- (a) Sensitivity
 - (b) Accuracy
 - (c) Reproducibility
 - (d) All of the above
7. In measurement systems, which of the following are undesirable static characteristics?
- (a) Reproducibility and nonlinearity
 - (b) Drift, static error and dead zone
 - (c) Sensitivity and accuracy
 - (d) Drift, static error, dead zone and nonlinearity
8. In some temperature measurement, the reading is recorded as 25.70°C. The reading has
- (a) five significant figures
 - (b) four significant figures
 - (c) three significant figures
 - (d) none of the above
9. In the centre of a zero analog ammeter having a range of -10 A to +10 A, there is a detectable change of the pointer from its zero position on either side of the scale only as the current reaches a value of 1 A (on either side). The ammeter has a
- (a) dead zone of 1 A
 - (b) dead zone of 2 A
 - (c) resolution of 1 A
 - (d) sensitivity of 1 A
10. A dc circuit can be represented by an internal voltage source of 50 V with an output resistance of 100 kW. In order to achieve 99% accuracy for voltage measurement across its terminals, the voltage measuring device should have
- (a) a resistance of at least 10 W
 - (b) a resistance of 100 kW
 - (c) a resistance of at least 10 MW
 - (d) none of the above
11. In ac circuits, the connection of measuring instruments cause loading errors which may affect
- (a) only the phase of the quantity being measured
 - (b) only the magnitude of the quantity being measured
 - (c) both the phase and the magnitude of the quantity
 - (d) magnitude, phase and also the waveform of the quantity being measured
12. A pressure gauge is calibrated from 0–50 kN/m². It has a uniform scale with 100 scale divisions. One fifth of the scale division can be read with certainty. The gauge has a
- (a) dead zone of 0.2 kN/m²
 - (b) resolution of 0.1 kN/m²
 - (c) resolution of 0.5 kN/m²
 - (d) threshold of 0.1 kN/m²
13. A pressure measurement instrument is calibrated between 10 bar and 260 bar. The scale span of the instrument is
- (a) 10 bar
 - (b) 260 bar
 - (c) 250 bar

- (d) 270 bar
14. A Wheatstone bridge is balanced with all the four resistances equal to 1 kW each. The bridge supply voltage is 100 V. The value of one of the resistance is changed to 1010 W. The output voltage is measured with a voltage measuring device of infinite resistance. The bridge sensitivity is
- (a) 2.5 mV/W
 - (b) 10 V/W
 - (c) 25 mV/W
 - (d) none of the above
15. The main advantage of the null balance technique of measurement is that
- (a) it gives a quick measurement
 - (b) it does not load the medium
 - (c) it gives a centre zero value at its input
 - (d) it is not affected by temperature variation
16. The smallest change in a measured variable to which an instrument will respond is
- (a) resolution
 - (b) precision
 - (c) sensitivity
 - (d) accuracy
17. The desirable static characteristics of a measurement are
- (a) precision
 - (b) accuracy
 - (c) sensitivity
 - (d) all of these
18. The errors mainly caused by human mistakes are
- (a) systematic error
 - (b) instrumental error
 - (c) observational error
 - (d) gross error
19. Systematic errors are
- (a) environmental error
 - (b) observational error
 - (c) instrumental error
 - (d) all of the above
20. An analog ammeter is
- (a) an absolute instrument
 - (b) an indicating instrument
 - (c) a controlling instrument
 - (d) a recording instrument

Answers

1. (c)	2. (a)	3. (a)	4. (d)	5. (a)	6. (d)	7. (d)
8. (b)	9. (b)	10. (c)	11. (d)	12. (b)	13. (c)	14. (c)
15. (b)	16. (a)	17. (d)	18. (d)	19. (d)	20. (b)	

Short-answer Questions

1. Compare the advantages and disadvantages of electrical and mechanical measurement systems.
2. Explain the various classes of measuring instruments with examples.
3. Differentiate clearly between absolute and secondary instruments.
4. Explain analog and digital modes of operation. Why are the digital instruments becoming popular now? What is meant by ADC and DAC?
5. Briefly define and explain all the static characteristics of measuring instruments.
6. Explain *loading effect* in measurement systems.
7. Explain the terms *accuracy*, *sensitivity* and *resolution* as used for indicating instruments.
8. What are the different types of errors in a measuring instrument? Describe their source briefly.
9. What are fundamental and derived units? Briefly explain them.
10. What are the differences between primary and secondary standards?

Long-answer Questions

1. (a) What is measurement? What is meant by the term measurand? What is a measuring instrument?
(b) Write down the important precautions that should be taken while carrying out electrical measurements.
(c) With an example, explain the term *loading effect* in a measurement system.
2. (a) Explain the terms:
 - (i) Measurement
 - (ii) Accuracy
 - (iii) Precision
 - (iv) Sensitivity
 - (v) Reproducibility
(b) Define *random errors* and explain how they are analysed statistically.
3. (a) What are environmental, instrumental and observational errors? Briefly explain each of them.
(b) Three resistors have the following ratings:
 $R_1 = 47\ \Omega \pm 4\%$, $R_2 = 65\ \Omega \pm 4\%$, $R_3 = 55\ \Omega \pm 4\%$
Determine the magnitude and limiting errors in ohms and in percentage of the resistance of these resistors connected in series.
4. (a) What is the necessity of units in measurements? What are various SI units?
(b) Define the terms *units*, *absolute units*, *fundamental units* and *derived units* with suitable examples.
(c) What is systematic error and how can we reduce it?
5. (a) Distinguish between international, primary, secondary and working standards.
(b) What are the primary standards for time and frequency? Briefly discuss each of them.
(c) Describe the working principle, operation and constructional detail of a primary standard of emf.

2

Analog Meters

2.1

INTRODUCTION

An analog device is one in which the output or display is a continuous function of time and bears a constant relation to its input. Measuring instruments are classified according to both the quantity measured by the instrument and the principle of operation. Three general principles of operation are available: (i) electromagnetic, which utilises the magnetic effects of electric currents; (ii) electrostatic, which utilises the forces between electrically charged conductors; (iii) electro-thermal, which utilises the heating effect.

Electric measuring instruments and meters are used to indicate directly the value of current, voltage, power or energy. In this chapter, we will consider an electromechanical meter (input is as an electrical signal which results in mechanical force or torque as an output) that can be connected with additional suitable components in order to act as an ammeter and a voltmeter. The most common analog instrument or meter is the permanent magnet moving coil instrument and it is used for measuring a dc current or voltage of an electric circuit. On the other hand, the indications of alternating current ammeters and voltmeters must represent the rms values of the current, or voltage, respectively, applied to the instrument.

2.2

CLASSIFICATION OF ANALOG INSTRUMENTS

In a broad sense, analog instruments may be classified into two ways:

1. Absolute instruments
2. Secondary instruments

Absolute instruments give the value of the electrical quantity to be measured in terms of the constants of the instruments and to its deflection, no comparison with another instrument being required. For example, the tangent galvanometer gives the value of the current to be measured in terms of the tangent of the angle of deflection produced by the current, the radius and the number of turns of galvanometer coil, and the horizontal component of the earth's magnetic field. No calibration of the instrument is thus necessary.

Secondary instruments are so constructed that the value of current, voltage or other quantity to be measured can be determined from the deflection of the instruments, only if the latter has been calibrated by comparison with either an absolute instrument or one which has already been calibrated. The deflection obtained is meaningless until such a calibration has been made.

This class of instruments is in most general use, absolute instrument being seldom used except in standard laboratories and similar institutions.

The secondary instruments may be classified as

1. Indicating instruments
2. Recording instruments
3. Integrating instruments

Indicating instruments are instruments which indicate the magnitude of a quantity being measured. They generally make use of a dial and a pointer for this purpose.

Recording instruments give a continuous record of the quantity being measured over a specified period. The variation of the quantity being measured are recorded by a pen (attached to the moving system of the instrument; the moving system is operated by the quantity being measured) on a sheet of paper that moves perpendicular to the movement of the pen.

Integrating instruments record totalised events over a specified period of time. The summation, which they give, is the product of time and an electrical quantity. Ampere hour and watt hour (energy) meters are examples of this category.

2.3

PRINCIPLE OF OPERATION

Analog instruments may be classified according to the principle of operation they utilise. The effects they utilise are

1. Magnetic effect
2. Heating effect
3. Electrostatic effect
4. Electromagnetic effect
5. Hall effect

The majority of analog instruments including moving coil, moving iron and electrodynamic utilise the magnetic effect. The effect of the heat produced by a current in a conductor is used in thermocouple and hotwire instruments. Electrostatic effect is used in electrostatic voltmeters. The electromagnetic induction effect is used in induction wattmeters and induction energy meters.

2.4

OPERATING TORQUES

Three types of torques are needed for satisfactory operation of any indicating instrument. These are

- Deflecting torque
- Controlling torque
- Damping torque

2.4.1 Deflecting Torque/Force

Any instrument's deflection is found by the total effect of the deflecting torque/force, control torque/ force and damping torque/force. The deflecting torque's value is dependent upon the electrical signal to be measured; this torque/force helps in rotating the instrument movement from its zero position. The system producing the deflecting torque is called the *deflecting system*.

2.4.2 Controlling Torque/Force

The act of this torque/force is opposite to the deflecting torque/force. When the deflecting and controlling torques are equal in magnitude then the movement will be in definite position or in equilibrium. Spiral springs or gravity is usually given to produce the controlling torque. The system which produces the controlling torque is called the *controlling system*. The functions of the controlling system are

- To produce a torque equal and opposite to the deflecting torque at the final steady position of the pointer in order to make the deflection of the pointer definite for a particular magnitude of current
- To bring the moving system back to its zero position when the force causing the instrument moving system to deflect is removed

The controlling torque in indicating instruments is almost always obtained by a spring, much less commonly, by gravity.

2.4.3 Damping Torque/Force

A damping force generally works in an opposite direction to the movement of the moving system. This opposite movement of the damping force, without any oscillation or very small oscillation brings the moving system to rest at the final deflected position quickly. Air friction, fluid friction and eddy currents provide the damping torque/force to act. It must also be noted that not all damping force affects the steady-state deflection caused by a given deflecting force or torque. With the angular velocity of the moving system, the intensity of the damping force rises; therefore, its effect is greatest when it rotates rapidly and zero when the system rotation is zero. In the description of various types of instruments, detailed mathematical expressions for the damping torques are taken into consideration.

When the deflecting torque is much greater than the controlling torque, the system is called underdamped. If the deflecting torque is equal to the controlling torque, it is called *critically damped*. When deflecting torque is much less than the controlling torque, the system is under overdamped condition. [Figure 2.1](#) shows the variation of deflection (d) with time for underdamped, critically damped and overdamped systems.

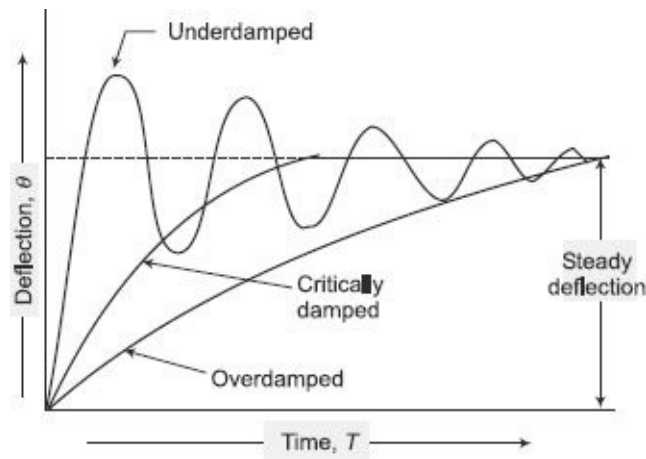

Figure 2.1 *Damping torque curve*

2.5

CONSTRUCTIONAL DETAILS

2.5.1 Moving System

The moving system should have the following properties:

- The moving parts should be light.
- The frictional force should be minimum.

These requirements should be fulfilled in order that power required by the instrument for its operation is small. The power is proportional to the weight of the moving parts and the frictional forces opposing the movement. The moving system can be made light by using aluminium as far as possible. The frictional forces are reduced by using spindle-mounted jewel bearings and by carefully balancing the system.

The force or torque developed by the moving element of an electrical instrument is necessarily small in order that the power consumption of the instrument is kept low so that the introduction of the instrument into a circuit may cause minimum change in the existing circuit conditions. Because of low power levels, the considerations of various methods of supporting the moving elements becomes of vital importance. With the operating force being small, the frictional force must be kept to a minimum in order that the instrument reads correctly and is not erratic in action and is reliable. Supports may be of the following types:

- Suspension
- Taut suspension
- Pivot and jewel bearings

1. *Suspension*

It consist of a fine, ribbon-shaped metal filament for the upper suspension and a coil of fine wire for the lower part. The ribbon is made of a spring material like beryllium copper or μ Hosphor bronze. This coiling of lower part of suspension is done in order to give

negligible restraint on the moving system. The type of suspension requires careful leveling of the instrument, so that the moving system hangs in correct vertical position. This construction is, therefore, not suited to field use and is employed only in those laboratory applications in which very great sensitivity is required. In order to prevent shocks to the suspension during transit, etc., a clamping arrangement is employed for supporting the moving system.

2. Taut Suspension

A suspension type of instrument can only be used in vertical position. The taut suspension has a flat ribbon suspension both above and below the moving element, with suspension kept under tension by a spring arrangement (Figure 2.2). The advantage of this type of suspension is that exact levelling is not required if the moving system is properly balanced.

Suspension and taut suspension are customarily used in instruments of galvanometer class which requires a low friction and high sensitivity mechanism. But actually there is no strict line of demarcation between a galvanometer and other indicating instruments. Some sensitive wattmeters and electrostatic voltmeters use flexible suspension.

Ribbon suspension, in addition to supporting the moving element, exerts a controlling torque when twisted. Thus, the use of suspension results in elimination of pivots, jewels, control springs and therefore, pivotless instruments are free from many defects.

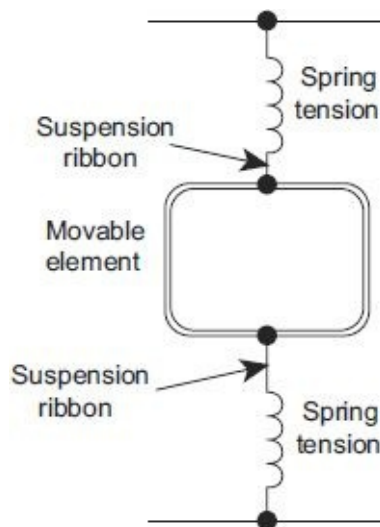

Figure 2.2 Taut suspension

3. Pivot and Jewel Bearings

The moving system is mounted on a spindle made of hardened steel. The two ends of the spindle are made conical and then polished to form pivots. These ends fit conical holes in jewels located in the fixed part of instruments (Figure 2.3). These jewels, which are preferably made of sapphire, form bearings.

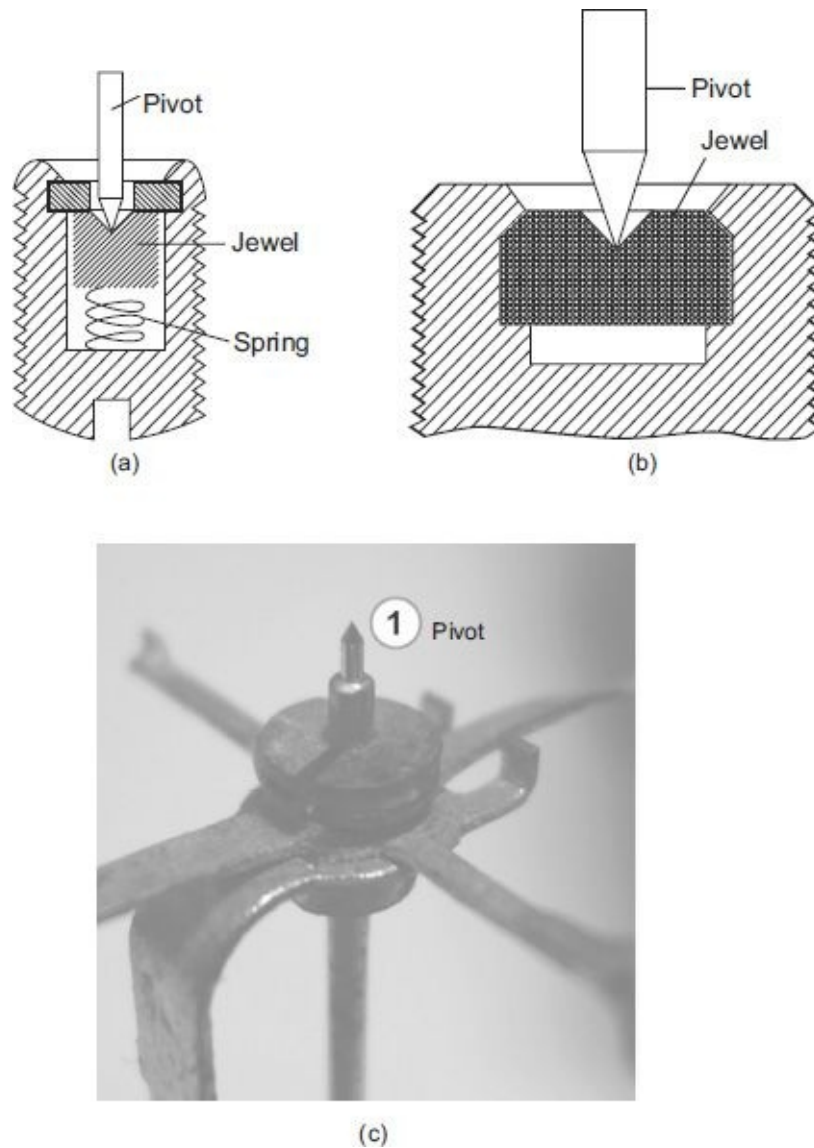

Figure 2.3 (a) Spring-loaded jewel bearing (b) Jewel bearing (c) Pivot

It has been found that the frictional torque, for jewel bearings, is proportional to the area of contact between the pivot and jewel. Thus, the contact area between a pivot and jewel should be small. The pivot is ground to a cone and its tip is rounded to a hemispherical surface of small area. The jewel is ground to a cone of somewhat larger angle.

4. Torque/Weight Ratio

The frictional torque in an instrument depends upon the weight of moving parts. If the weight of the moving parts is large, the frictional torque will be large. The frictional torque exerts a considerable influence on the performance of an indicating instrument. If the frictional torque is large and is comparable to a considerable fraction of the deflecting torque, the deflection of the moving system will depend upon the frictional torque to an appreciable extent. Also, the deflection will depend on the direction from which the equilibrium position is approached and will be uncertain. On the other hand, if the frictional torque is very small compared with the deflecting torque, its effect on deflection is negligible. Thus, the ratio of deflecting torque to frictional torque is a measure of reliability of the instrument indications and is the inherent quality of the design. Hence (deflecting) torque/weight ratio of an instrument is an index of its performance. The higher the ratio, the better will be its performance.

2.5.2 Controlling System

The controlling torque is provided by a spring or sometimes by gravity.

1. Spring Control

A hair-spring, usually of phosphor-bronze attached to the moving system, is used in indicating instruments for control purpose, the schematic arrangement being shown in Figure 2.4(a) and the actual controlling spring used in the instrument is shown in Figure 2.4(b).

To give a controlling torque which is directly proportional to the angle of deflection of the moving system, the number of turns on the spring should be fairly large, so that the deflection per unit length is small. The stress in the spring must be limited to such a value that there is no permanent set.

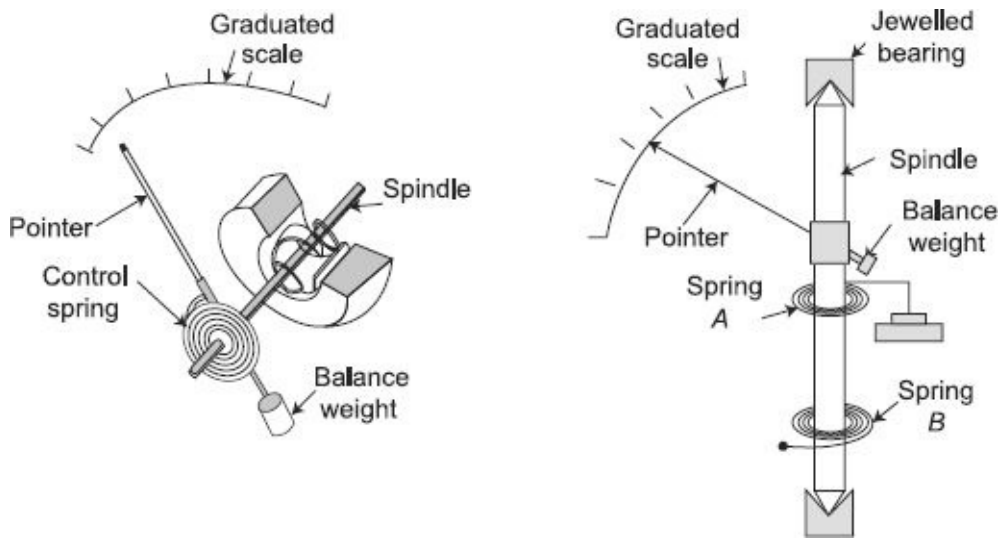

Figure 2.4(a) Spring control



Figure 2.4(b) Spring control in an instrument

Suppose that a spiral spring is made up of a total length L m of strip whose cross-section is rectangular, the radial thickness being t m and the depth b m. Let E be Young's modulus (N/m^2) for the material of the spring. Then, if θ radians be the deflection of the moving system to which one end of the spring is being attached, the expression for the controlling torque is

$$T_c = \frac{Ebt^3}{12I} \theta \quad (2.1)$$

Thus, controlling torque $\propto \theta \propto$ instrument deflection.

2. Gravity Control

In a gravity-controlled instrument, a small weight is attached to the moving system in such a way that it produces a restoring or controlling torque when the system is deflected. This is illustrated in Figure 2.5. The controlling torque, when the deflection is θ , is $\omega l \sin \theta$, where W is the control weight and l its distance from the axis of rotation of the moving system, and it is, therefore, proportional only to the *sine* of the angle of deflection, instead of, as with spring control, being directly proportional to the angle of deflection. Gravity-controlled instruments must obviously be used in a vertical position in order that the control may operate.

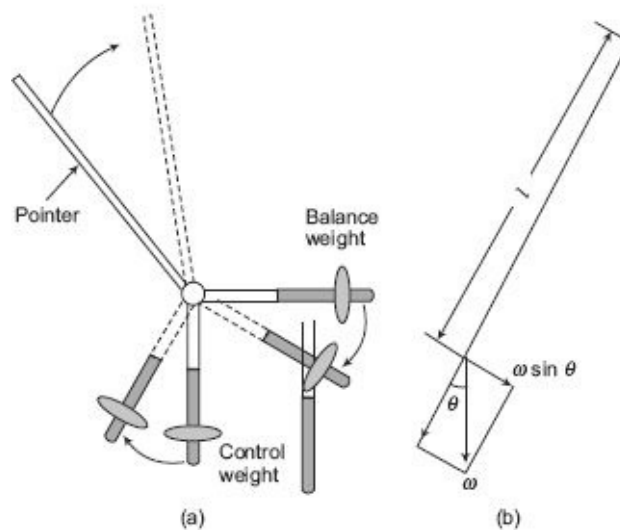

Figure 2.5 Gravity control

3. Comparison of Spring and Gravity Control

Gravity control has the following advantages when compared with spring control:

- It is cheaper
- Independent of temperature
- Does not deteriorate with time

Consider an instrument in which the deflecting torque T_D is directly proportional to the current (say) to be measured.

Thus, if I is the current,

$$T_D = kI, \text{ (where } k \text{ is a constant)} \quad (2.2)$$

If the instrument is spring-controlled, the controlling torque being T_C , when the deflection is θ ,

$$T_C = k_s \theta \quad (k_s \text{ is spring constant})$$

Also, $T_C = T_D$

or $k_s \theta = kI$

$$\begin{aligned} \text{or} \quad & k_s \theta = kI \\ \therefore \quad & \theta = \frac{k}{k_s} \cdot I \end{aligned} \tag{2.3}$$

Thus, the deflection is proportional to the current throughout the scale.

Now if the same instrument is gravity controlled,

$$T_c = k_g \sin \theta \quad (k_g \text{ is a constant that depends upon the control weight and its distance from the axis of rotation of the moving system}).$$

And $T_C = T_D = kI$

$$\begin{aligned} \therefore \quad & k_g \sin \theta = kI \\ & \sin \theta = \frac{k}{k_g} \cdot I \\ & \theta = \sin^{-1} \left(\frac{k}{k_g} \cdot I \right) \end{aligned} \tag{2.4}$$

Thus, a gravity-controlled instrument would have a scale which is ‘cramped’ at its lower end instead of being uniformly divided, though the deflecting torque is directly proportional to the quantity to be measured.

2.5.3 Damping System

There are three systems of damping generally used. These are as follows:

- Air-friction damping
- Fluid-friction damping
- Eddy-current damping

1. Air-Friction Damping

In this method, a light aluminium piston is attached to the moving system and moves in an air chamber closed at one end, as shown in [Figure 2.6](#). The cross-section of this chamber may be either circular or rectangular. The clearance between the piston and the sides of the chamber should be small and uniform. If the piston is moving rapidly into the chamber, the air in the closed space is compressed and the pressure opposes the motion of the piston (and, therefore, of the whole moving system). If the piston is moving out of the chamber rapidly, the pressure in the closed space falls, and the pressure on the open side of the piston is greater than that on the opposite side. Motion is thus again opposed. Sometimes instead of a piston, a vane, mounted on the spindle of the moving system, moves in a

closed-sector-shaped box as shown in [Figure 2.7](#).

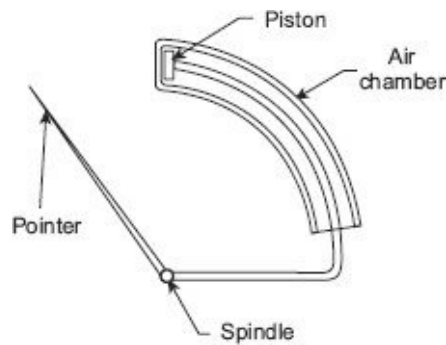

Figure 2.6 Open-end air friction damping

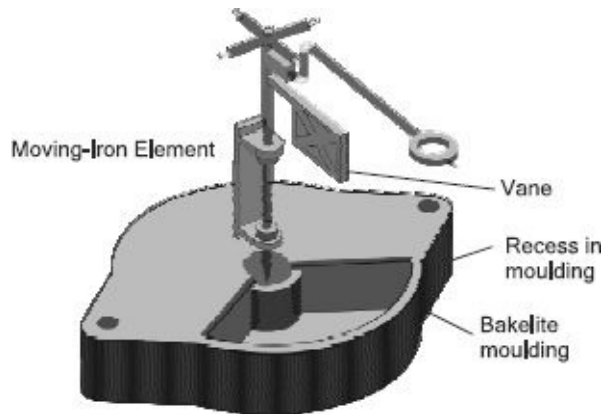

Figure 2.7 Air-friction damping using vane

2. Fluid-Friction Damping

In this type of damping, a light vane, attached to the spindle of the moving system, dips into a pot of damping oil and should be completely submerged by the oil. This is illustrated in [Figure 2.8\(a\)](#). The frictional drag in the disc is always in the direction opposing motion. There is no friction force when the disc is stationary. In the second system [[Figure 2.8\(b\)](#)], increased damping is obtained by the use of vanes.

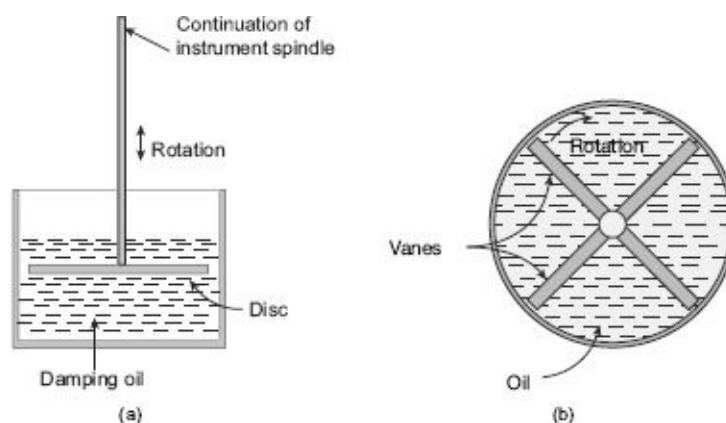

Figure 2.8 Fluid-friction damping

3. Eddy-Current Damping

When a sheet of conducting material moves in a magnetic field so as to cut through lines of force, eddy currents are set up in it and a force exists between these currents and the magnetic field, which is always in the direction opposing the motion. The force is proportional to the magnitude of the current and to the strength of the field. The

magnitude of the current is proportional to the velocity of movement of the conductor, and thus, if the magnetic field is constant, the damping force is proportional to the velocity of the moving system and is zero when there is no movement of the system.

(i) Eddy-Current Damping Torque of Metal Former Figure 2.9 shows a metallic former moving in the field of a permanent magnet.

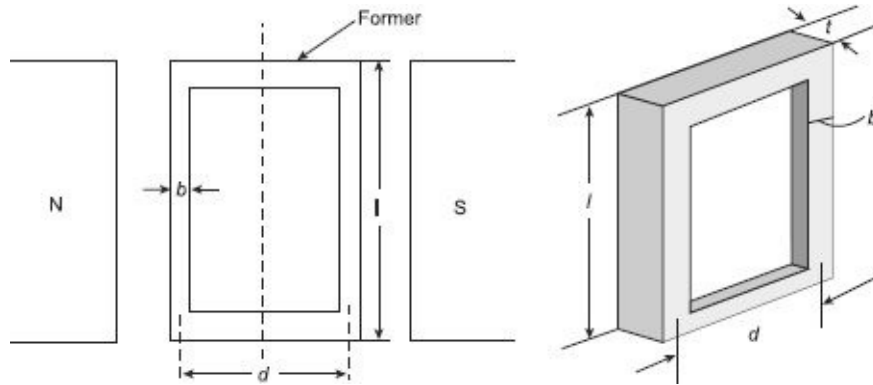

Figure 2.9 Eddy-current damping on a metal former

Let,

B = strength of magnetic field; (wb/m²)

ω = angular speed of former; (rad/s)

l = length of former; (m)

t = thickness of former; (m)

b = width of former; (m)

d = breadth of former; (m)

ρ = resistivity of material of former; (W m)

$$\text{Linear velocity of former } v = \left(\frac{d}{2}\right)\omega \quad (2.5)$$

[since linear velocity = radius \times angular velocity]

Dynamically generated emf in the former

$$E_e = 2Blv = 2Bl\left(\frac{d}{2}\right)\omega = Bld\omega \quad (2.6)$$

$$\text{Resistance of path of eddy current } R_e = \frac{\rho 2(d+l)}{bt} \quad (2.7)$$

$$\text{Eddy current } I_e = \frac{E_e}{R_e} = \frac{Blbt\omega}{2\rho(d+l)} \quad (2.8)$$

$$\therefore \text{ damping force } F_d = BI_e l = \frac{B^2 l^2 b t d \omega}{2\rho(d+l)} \quad (2.9)$$

$$\text{damping torque } T_d = F_d \times d = \frac{B^2 l^2 b t d^2 \omega}{2\rho(d+l)} \quad (2.10)$$

$$\text{damping constant } k_d = \frac{T_d}{\omega} = \frac{B^2 l^2 b t d^2}{2\rho(d+l)} \text{ Nm/rad s}^{-1} \quad (2.11)$$

(ii) Eddy-Current Damping Torque of Metal Disc Figure 2.10 shows a metallic disc

rotating in the field of a permanent magnet.

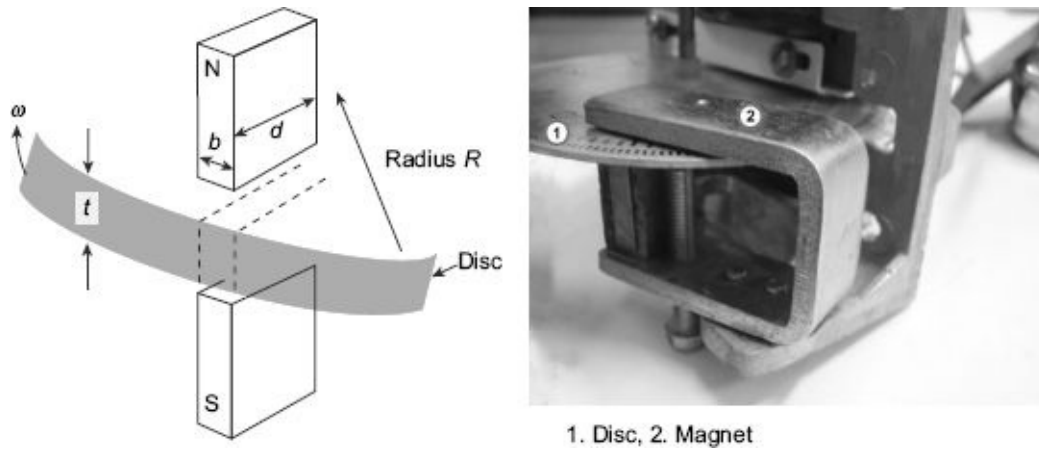

Figure 2.10 Eddy-current damping on metallic disc 2

Let, $B =$ flux density of magnetic field; (wb/m^2)

$\omega =$ angular speed of disc; (rad/s)

$t =$ thickness of disc; (m)

$b =$ width of permanent magnet; (m)

$d =$ length of permanent magnet; (m)

$\rho =$ resistivity of material of disc; ($\Omega \text{ m}$)

$R =$ radius measured from centre of pole to centre of disc; (m)

Considering the emf is induced in the disc under the pole face only, therefore, emf induces in the portion below the magnet

$$E_c = Blv = BdR\omega \quad (2.12)$$

[since 'l', length of the portion of the disc under the magnetic field = d]

$$\text{Resistance of eddy-current path under the pole} = \frac{\rho d}{bt} \quad (2.13)$$

Actual path for eddy current is not limited to the portion of the disc under the magnet but is greater than this. Therefore, to take this factor into account, the actual resistance is taken as k times of $\frac{\rho d}{bt}$.

$$\text{Therefore, resistance of eddy-current path } R_c = k \frac{\rho d}{bt} \quad (2.14)$$

where k is a constant which depends upon radial position of the disc and poles.

$$\text{Eddy current } I_e = \frac{E_c}{R_c} = \frac{BRbt\omega}{k\rho} \quad (2.15)$$

$$\text{Damping force } F_D = B \times I_e \times d = \frac{B^2 Rdbt\omega}{k\rho} (\text{N}) \quad (2.16)$$

$$\text{Damping torque } T_D = F_D \times R = \frac{B^2 R^2 dbt\omega}{k\rho} (\text{N-m}) \quad (2.17)$$

$$\text{Damping constant } K_D = \frac{T_D}{\omega} = \frac{B^2 R^2 dbt}{k\rho} (\text{N-m}/\text{rad s}^{-1}) \quad (2.18)$$

Basic range: 10 μA -100 mA

Coil resistance: 10 Ω -1 k Ω

Usage:

- dc PMMC ammeters and voltmeters
- ac PMMC ammeters and voltmeters (with rectifiers)

2.6.1 Principle of Operation

The principle on which a Permanent Magnet Moving Coil (PMMC) instrument operates is that a torque is exerted on a current-carrying coil placed in the field of a permanent magnet. A PMMC instrument is shown in [Figure 2.11](#). The coil C has a number of turns of thin insulated wires wound on a rectangular aluminium former F . The frame is carried on a spindle S mounted in jewel bearings J_1, J_2 . A pointer PR is attached to the spindle so that it moves over a calibrated scale. The whole of the moving system is made as light in weight as possible to keep the friction at the bearing to a minimum.

The coil is free to rotate in air gaps formed between the shaped soft-iron pole piece (pp) of a permanent magnet PM and a fixed soft-iron cylindrical core IC [[Figure 2.11\(b\)](#)]. The core serves two purposes; (a) it intensifies the magnetic field by reducing the length of the air gap, and (b) it makes the field radial and uniform in the air gap.

Thus, the coil always moves at right angles to the magnetic field [[Figure 2.11\(c\)](#)]. Modern permanent magnets are made of steel alloys which are difficult to machine. Soft-iron pole pieces (pp) are attached to the permanent magnet PM for easy machining in order to adjust the length of the air gap. [Figure 2.11\(d\)](#) shows the internal parts and [Figure 2.11\(e\)](#) shows schematic of internal parts of a moving-coil instrument.

A soft-iron yoke (Y) is used to complete the flux path and to provide shielding from stray external fields.

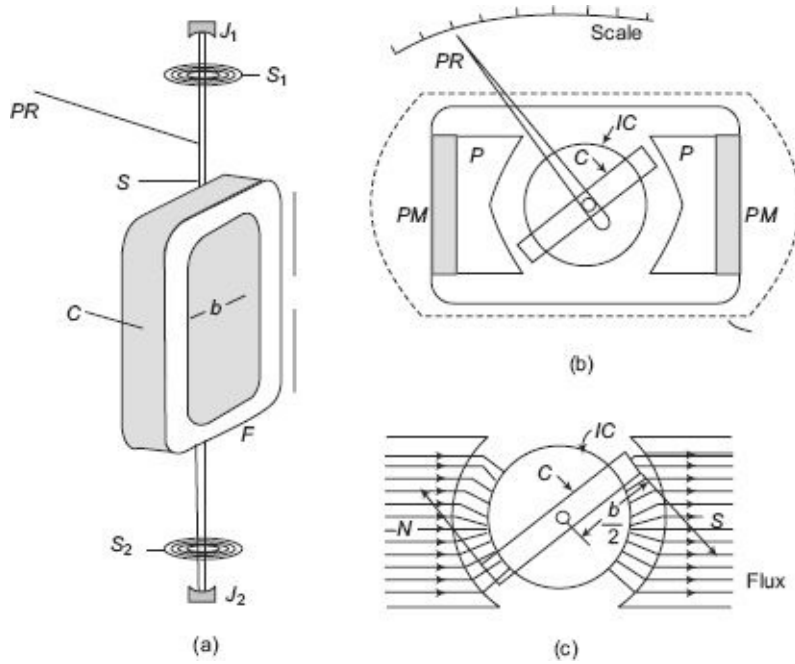

Permanent magnet moving coil instrument

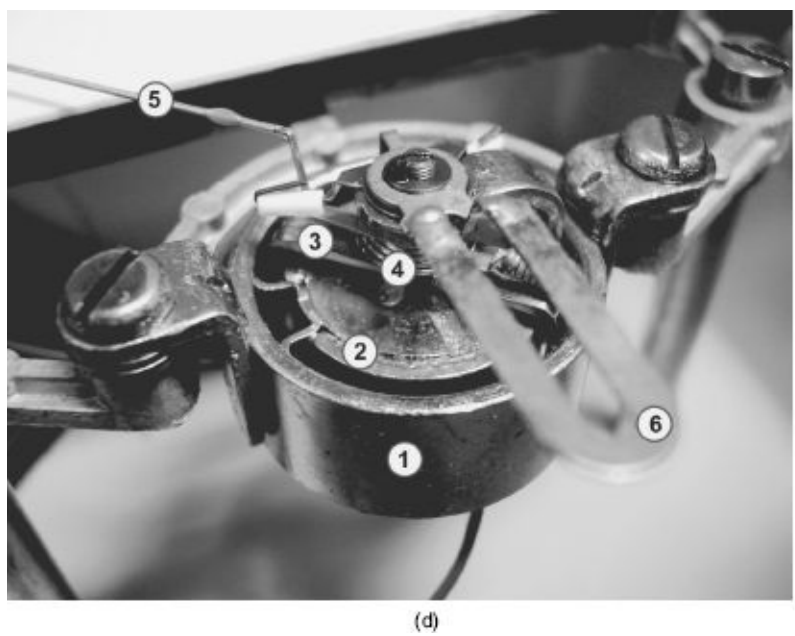

- 1. External shield
- 2. Permanent magnet
- 3. Moving coil
- 4. Control spring
- 5. Pointer
- 6. Arrangement for zero balance of the pointer

Photograph of different components of a PMMC instrument

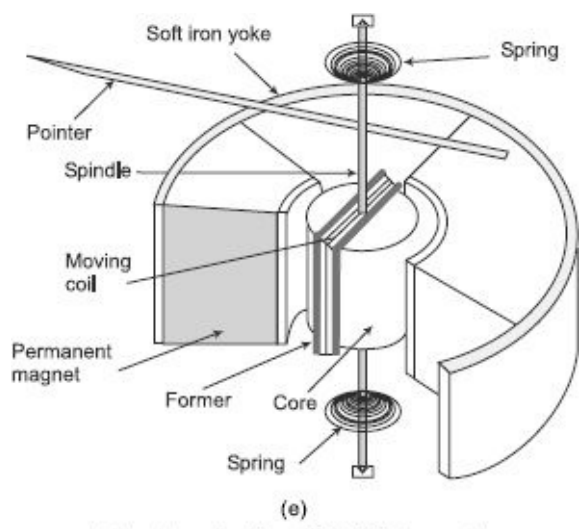

Internal construction of PMMC instruments

Internal construction of PMMC instruments **Figure 2.11**

2.6.2 Deflecting Torque Equation of PMMC Instrument

Let, B = flux density in the air gap (wb/m^2)

i = current in the coil (A)

l = effective axial length of the coil (m)

b = breadth of the coil (m)

n = number of turns of the coil.

Force on one side of the coil is

$$F = Biln \text{ (N)} \quad (2.19)$$

Torque on each side of the coil,

$$\begin{aligned} T &= \text{force} \times \text{distance from axis of rotation} \\ &= F \times b/2 \\ &= Biln \times b/2 \end{aligned} \quad (2.20)$$

Total deflecting torque exerted on the coil,

$$\begin{aligned} T_d &= 2 \times T = 2iln \times b/2 \\ &= Bilnb \text{ (N-m)} \end{aligned} \quad (2.21)$$

For a permanent magnet, B is constant. Also, for a given coil l , b and n are constants and thus the product $(Blnb)$ is also a constant, say k_1 .

$$\text{Therefore, } T_d = k_1 \times i \quad (2.22)$$

1. Control Torque The control on the movement of the pointer over the scale is provided by two spirally wound, phosphor-bronze springs S_1 and S_2 , one at each end of the spindle S . Sometimes these springs also conduct the current into and out of the coil. The control torque of the springs is proportional to the angle θ turned through by the coil.

$$T_c = k_s \times \theta \quad (2.23)$$

where T_c is the control torque and k_s is the spring constant.

At final steady state position, Control torque = Deflecting torque

$$\begin{aligned} \therefore T_c &= T_d \\ k_s \theta &= k_1 i \end{aligned}$$

or $\theta = \frac{k_1}{k_s} i = ki$ (2.24)

where $k = \frac{k_1}{k_s} = \text{constant}$

So, angular deflection of the pointer is directly proportional to the current. Thus the scale of the instrument is linear or uniformly divided.

2. Damping Torque When the aluminium former (F) moves with the coil in the field of the permanent magnet, a voltage is induced, causing eddy current to flow in it. These current exerts a force on the former. By Lenz's law, this force opposes the motion producing it. Thus, a damping torque is obtained. Such a damping is called eddy-current damping.

2.6.3 Swamping Resistor

The coil of the instrument is made of copper. Its resistance varies with temperature. A resistor of low temperature coefficients, called the swamping resistor, is connected in series with the coil. Its resistance practically remains constant with temperature. Hence the effect of temperature on coil resistance is swamped by this resistor.

Advantages of PMMC Instruments

1. Sensitive to small current
2. Very accurate and reliable
3. Uniform scale up to 270° or more
4. Very effective built in damping
5. Low power consumption, varies from 25 μW to 200 μW
6. Free from hysteresis and not effected by external fields because its permanent magnet shields the coil from external magnetic fields
7. Easily adopted as a multirange instrument

Disadvantages of PMMC Instruments

1. This type of instrument can be operated in direct current only. In alternating current, the instrument does not operate because in the positive half, the pointer experiences a force in one direction and in the negative half the pointer experiences the force in the opposite direction. Due to the inertia of the pointer, it retains it's zero position.
2. The moving system is very delicate and can easily be damaged by rough handling.
3. The coil being very fine, cannot withstand prolonged overloading.
4. It is costlier.
5. The ageing of the instrument (permanent magnet and control spring) may introduce some errors.

Example 2.1

The coil of a PMMC instrument has 60 turns, on a former that is 18 mm wide, the effective length of the conductor being 25 mm. It moves in a uniform field of flux density 0.5 Tesla. The control spring constant is 1.5×10^{-6} Nm/degree. Calculate the current required to produce a deflection of 100 degree.

Solution Total deflecting torque exerted on the coil,

$$T_d = Bilnb \text{ (N-m)}$$

$$= 0.5 \times i \times 25 \times 10^{-3} \times 60 \times 18 \times 10^{-3}$$

The control torque of the springs is

$$T_C = k_s \times \theta$$

$$= 1.5 \times 10^{-6} \times 100$$

At equilibrium, $T_d = T_C$

$$= 0.5 \times i \times 18 \times 10^{-3} \times 25 \times 10^{-3} \times 60 = 1.5 \times 10^{-6} \times 100$$

$$i = \frac{1.5 \times 10^{-6} \times 100}{0.5 \times 18 \times 10^{-3} \times 25 \times 10^{-3} \times 60} = 11.11 \text{ mA}$$

Example 2.2

A PMMC instrument has a coil of dimensions $15 \text{ mm} \times 12 \text{ mm}$. The flux density in the air gap is $1.8 \times 10^{-3} \text{ wb/m}^2$ and the spring constant is $0.14 \times 10^{-6} \text{ N-m/rad}$. Determine the number of turns required to produce an angular deflection of 90° when a current of 5 mA is flowing through the coil.

Solution Total deflecting torque exerted on the coil,

$$T_d = Bilnb \text{ (N-m)}$$

$$= 1.8 \times 10^{-3} \times 5 \times 10^{-3} \times 15 \times 10^{-3} \times 12 \times 10^{-3} \times n$$

The control torque of the springs is

$$T_C = k_s \times \theta$$

$$= 0.14 \times 10^{-6} \times 90 \times \pi/180$$

At equilibrium, $T_d = T_C$

$$1.8 \times 10^{-3} \times 5 \times 10^{-3} \times 15 \times 10^{-3} \times 12 \times 10^{-3} \times n = 0.14 \times 10^{-6} \times 90 \times \pi/180$$

$$n = \frac{0.14 \times 10^{-6} \times 90 \times \pi/180}{1.8 \times 10^{-3} \times 5 \times 10^{-3} \times 15 \times 10^{-3} \times 12 \times 10^{-3}} = 136$$

Example 2.3

A PMMC voltmeter with a resistance of 20Ω gives a full-scale deflection of 120° when a potential difference of 100 mV is applied across it. The moving coil has dimensions of $30 \text{ mm} \times 25 \text{ mm}$ and is wound with 100 turns. The control spring constant is $0.375 \times 10^{-6} \text{ N-m/degree}$. Find the flux density in the air gap. Find also the dimension of copper wire of coil winding if 30% of the instrument resistance is due to coil winding. The specific resistance of copper is $1.7 \times 10^{-8} \Omega\text{m}$.

Solution Full-scale deflecting current

$$i = \frac{100}{20} \times 10^{-3} = 5 \times 10^{-3} \text{ A}$$

Total deflecting torque exerted on the coil,

$$T_d = Bilnb \text{ (N-m)}$$

$$= B \times 5 \times 10^{-3} \times 30 \times 10^{-3} \times 25 \times 10^{-3} \times 100$$

The control torque of the springs is

$$T_C = k_s \times \theta$$

$$= 0.375 \times 10^{-6} \times 120$$

At equilibrium, $T_d = T_C$

$$B \times 5 \times 10^{-3} \times 30 \times 10^{-3} \times 25 \times 10^{-3} \times 100 = 0.375 \times 10^{-6} \times 120$$

$$B = \frac{0.375 \times 10^{-6} \times 120}{5 \times 10^{-3} \times 30 \times 10^{-3} \times 25 \times 10^{-3} \times 100} = 0.12 \text{ wb/m}^2$$

Coil winding resistance = $20 \times 0.3 = 6 \Omega$

If the copper wire has a cross-sectional area of a m then

$$n\rho \frac{l}{a} = R \text{ [where } n \text{ be the number of turns, } \rho \text{ is the resistivity of the copper wire, } l \text{ is the length of the wire and } a \text{ is the cross-sectional area]}$$

$$100 \times 1.7 \times 10^{-8} \times \frac{2 \times (30 + 25) \times 10^{-3}}{a} = 6$$

$$a = 100 \times 1.7 \times 10^{-8} \times \frac{2 \times (30 + 25) \times 10^{-3}}{6} = 31.16 \times 10^{-3} \text{ mm}^2$$

If d be the diameter of the copper wire then

$$d = \sqrt{\frac{4 \times 31.16 \times 10^{-3}}{\pi}} = 0.199 \text{ mm}$$

The coil of a moving-coil voltmeter is 40 mm long and 30 mm wide and has 100 turns on it. The control spring exerts a torque of 240×10^{-6} N-m when the deflection is 100 divisions on full scale. If the flux density of the magnetic field in the air gap is 1 wb/m^2 , estimate the resistance that must be put in series with the coil to give one volt per division. The resistance of the voltmeter coil may be neglected.

Example 2.4

Solution Let the full scale deflecting current be I amp.

Total deflecting torque exerted on the coil,

$$T_d = Bilnb \text{ (N-m)}$$

$$= 1 \times I \times 40 \times 10^{-3} \times 30 \times 10^{-3} \times 100$$

The control torque of the springs is

$$T_C = k_s \times \theta$$

$$= 240 \times 10^{-6}$$

At equilibrium, $T_d = T_C$

$$1 \times I \times 40 \times 10^{-3} \times 30 \times 10^{-3} \times 100 = 240 \times 10^{-6}$$

$$I = \frac{240 \times 10^{-6}}{1 \times 40 \times 10^{-3} \times 30 \times 10^{-3} \times 100} = 0.002 \text{ A}$$

If R be the series resistance,

$$R = \frac{V}{I} = \frac{100 \times 1}{0.002} = 50 \times 10^3 \Omega$$

2.7

EXTENSION OF RANGE OF PMMC INSTRUMENTS

2.7.1 Ammeter Shunts

The moving-coil instrument has a coil wound with very fine wire. It can carry only few mA safely to give full-scale deflection. For measuring higher current, a low resistance is connected in parallel to the instrument to bypass the major part of the current. The low resistance connected in parallel with the coil is called a *shunt*. Figure 2.12 shows a shunt resistance R_{sh} connected in parallel with the basic meter.

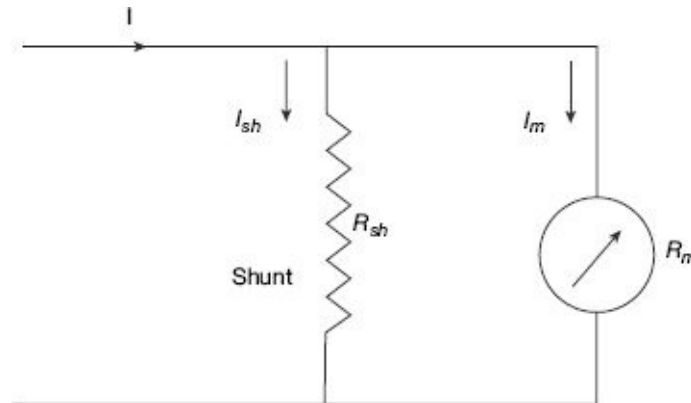

Figure 2.12 Extension of PMMC ammeter using shunt

The resistance of the shunt can be calculated using conventional circuit analysis.

$$R_{sh} = \text{shunt resistance } (\Omega)$$

$$R_m = \text{coil resistance } (\Omega)$$

$$I_m = I_{fs} = \text{full-scale deflection current (A)}$$

$$I_{sh} = \text{shunt current (A)}$$

$$I = \text{current to be measured (A)}$$

The voltage drop across the shunt and the meter must be same as they are connected in parallel.

$$\begin{aligned} \therefore I_{sh}R_{sh} &= I_m R_m \\ \text{Again } I &= I_{sh} + I_m \\ \therefore I_{sh} &= I - I_m \end{aligned} \quad (2.25)$$

From Eq. (2.25),

$$\begin{aligned} R_{sh} &= \frac{I_m}{I - I_m} R_m \\ \therefore R_{sh} &= \frac{I_m}{I - I_m} R_m \end{aligned} \quad (2.26)$$

The ratio of the total current to the current in the meter is called *multiplying power of shunt*. Multiplying power,

$$\begin{aligned} m &= \frac{I}{I_m} = 1 + \frac{R_m}{R_{sh}} \\ \therefore R_{sh} &= \frac{R_m}{m - 1} \end{aligned}$$

2.7.2 Voltmeter Multipliers

For measuring higher voltages, a high resistance is connected in series with the instrument to limit the current in the coil to a safe value. This value of current should never exceed the current required to produce the full scale deflection. The high resistance connected in series with the instrument is called a *multiplier*. In [Figure 2.13](#), R_{sc} is the multiplier.

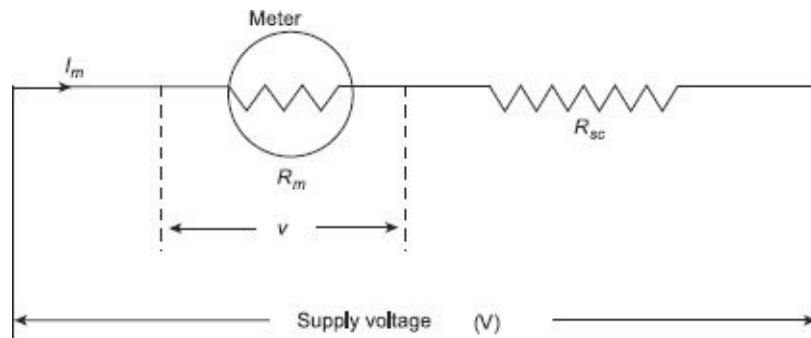

Figure 2.13 Extension of PMMC voltmeter using multiplier

The value of multiplier required to extend the voltage range, is calculated as under:

$$R_{sc} = \text{multiplier resistance } (\Omega)$$

$$R_m = \text{meter resistance } (\Omega)$$

$$I_m = I_{fs} = \text{full scale deflection current (A)}$$

$$v = \text{voltage across the meter for producing current } I_m \text{ (A)}$$

$$V = \text{voltage to be measured (A)}$$

$$V = I_m R_m$$

$$V = I_m (R_m + R_{sc})$$

$$\therefore R_{sc} = \frac{V - I_m R_m}{I_m} = \frac{V}{I_m} - R_m$$

Now multiplying factor for multiplier

$$m = \frac{V}{v} = \frac{I_m(R_m + R_{sc})}{I_m R_m} = 1 + \frac{R_{sc}}{R_m}$$

$$\therefore R_{sc} = (m - 1)R_m$$

Sensitivity The moving-coil instrument is a very sensitive instrument. It is, therefore, widely used for measuring current and voltage. The coil of the instrument may require a small amount of current (in the range of μA) for full-scale deflection. The sensitivity is sometimes expressed in *ohm/volt*. The sensitivity of a voltmeter is given by

$$S = \frac{\text{Total voltmeter resistance in ohm}}{\text{Full scale reading in volts}} \Omega/v = \frac{R_m}{v} = \frac{1}{I_{fs}} \Omega/v$$

where I_{fs} is the full-scale deflecting current. Thus, the sensitivity depends upon on the current to give full-scale deflection.

Example 2.5

A moving-coil voltmeter has a resistance of 100 Ω . The scale is divided into 150 equal divisions. When a potential difference of 1 V is applied to the terminals of the voltmeter a deflection of 100 divisions is obtained. Explain how the instrument could be used for measuring up to 300 V.

Solution Let R_{sc} be the multiplier resistance that would be connected in series with the voltmeter.

$$\text{Volt/division} = 1/100$$

$$\text{Voltage across the meter for producing the full-scale deflecting current } v = 150 \times 1/100 = 1.5 \text{ V}$$

$$\text{Full scale meter current } I_m = 1.5/100 \text{ amp}$$

$$\text{Meter resistance } R_m = 100 \Omega$$

$$\begin{aligned} \therefore R_{sc} &= \frac{V - I_m R_m}{I_m} = \frac{V}{I_m} - R_m \\ &= \frac{300 - 1.5/100 \times 100}{1.5/100} = 19.9 \text{ k}\Omega \end{aligned}$$

Example 2.6

A moving coil instrument has a resistance of 5 Ω and gives a full scale deflection of 10 mv. Show how the instrument may be used to measure (a) voltage up to 50 v, and (b) current up to 10 A.

Solution Full scale deflection of 10 mv

$$\text{Full scale deflection current} = 10 \times 10^{-3}/5 = 2 \text{ mA}$$

- (a) For measuring the voltage up to 50 V we need to connect a multiplier resistance R_{SC} in series with the instrument

$$\text{Thus, } R_{SC} = (m - 1) R_m, \text{ where } m = \frac{V}{V_m}$$

$$\therefore R_{SC} = \left(\frac{50}{10 \times 10^{-3}} - 1 \right) \times 5 = 24995 \Omega$$

- (b) For measuring the current up to 10 A we need to connect a shunt resistance in parallel to the instrument.

$$\text{Thus, } R_{Sh} = \frac{R_m}{m-1}, \quad \text{where } m = \frac{I}{I_m} = \frac{10}{2 \times 10^{-3}} = 5 \times 10^3$$

$$\therefore R_{Sh} = \frac{5}{5 \times 10^3 - 1} = 1.002 \times 10^{-3} \Omega$$

A moving-coil ammeter has a fixed shunt of 0.02 Ω. With a coil resistance of R = 1000 Ω and a potential difference of 500 mV across it. Full-scale deflection is obtained. (a) To what shunted current does it correspond? (b) Calculate the value of R to give full-scale deflection when shunted current I is (i) 10 A, and (ii) 75 A, (c) With what value of R, 40% deflection obtained with I = 100 A.

Example 2.7

Solution

- (a) Current through shunt $I_{sh} = 500 \times 10^{-3} / 0.02 = 25 \text{ A}$.

- (b) (i) Voltage across shunt for a current of 10 A = $0.02 \times 10 = 0.2 \text{ V}$.

Therefore, resistance of meter for a current of 10 A to give full scale deflection = $0.2 / (0.5 \times 10^{-3}) = 400 \Omega$

- (ii) Voltage across shunt for a current of 75 A = $0.02 \times 75 = 1.5 \text{ V}$. Therefore, resistance of meter for a current of 75 A to give full scale deflection = $1.5 / (0.5 \times 10^{-3}) = 3000 \Omega$

- (c) Now 40% deflection is obtained with 100 A.

Therefore, current to give full-scale deflection = $100 / 0.4 = 250 \text{ A}$

Voltage across shunt for a current of 250 A = $0.02 \times 250 = 5 \text{ V}$

Resistance of meter for a current of 100 A to give 40% of full scale deflection = $5 / (0.5 \times 10^{-3}) = 10,000 \Omega$

A simple shunted ammeter using a basic meter movement with an internal resistance of 1800 Ω and a full-scale deflection current of 100 pA is connected in a circuit and gives reading of 3.5 mA on its 5 mA scale. The reading is checked with a recently calibrated dc ammeter which gives a reading of 4.1 mA. The implication is that the ammeter has a faulty shunt on its 5 mA range. Calculate (a) the actual value of faulty shunt, and (b) the current shunt for the 5 mA range.

Example 2.8

Solution

(a) 5 mA scale deflection corresponds to 100 μ A.

Therefore, 3.5 mA corresponds to $\frac{100 \times 10^{-6} \times 3.5}{5} = 7 \times 10^{-5}$ A

As the shunt and the meter are connected in parallel, the drop across the shunt should be equal to the voltage drop across the meter. Meter current = 7×10^{-5} A
Shunt current = $(4.1 \times 10^{-3} - 7 \times 10^{-5})$ A Therefore, actual value of faulty shunt,

$$R_{sh} \times (4.1 \times 10^{-3} - 7 \times 10^{-5}) = 1800 \times 7 \times 10^{-5}$$

$$R_{sh} = \frac{1800 \times 7 \times 10^{-5}}{(4.1 \times 10^{-3} - 7 \times 10^{-5})} = 31.26 \Omega$$

(b) 5 mA scale deflection corresponds to 100 μ A.

Therefore, 4.1 mA corresponds to $\frac{100 \times 10^{-6} \times 4.1}{5} = 82 \times 10^{-6}$ A = 82×10^{-6} A

As the shunt and the meter are connected in parallel, then the drop across the shunt should be equal to the voltage drop across the meter.

Meter current = 82×10^{-6} A

Shunt current = $(4.1 \times 10^{-3} - 82 \times 10^{-6})$ A
Therefore, actual value of faulty shunt,

$$R_{sh} \times (4.1 \times 10^{-3} - 82 \times 10^{-6}) = 1800 \times 82 \times 10^{-6}$$

$$R_{sh} = \frac{1800 \times 82 \times 10^{-6}}{(4.1 \times 10^{-3} - 82 \times 10^{-6})} = 36.73 \Omega$$

Example 2.9

A moving-coil instrument gives the full-scale deflection of 10 mA when the potential difference across its terminals is 100 mV. Calculate (a) the shunt resistance for a full-scale deflection corresponding to 100 A, and (b) the series resistance for full scale reading with 1000 V. Calculate the power dissipation in each case.

Solution

(a) Meter resistance $R_m = 100 \text{ mV}/10 \text{ mA} = 10 \Omega$

The shunt resistance corresponds to 100 A full-scale deflection

$$R_{sh} = \frac{R_m}{m-1}, \text{ where } m = \frac{I}{I_m} = \frac{100}{10 \times 10^{-3}} = 10 \times 10^3$$

$$= \frac{10}{10 \times 10^3 - 1} = 0.001 \Omega$$

Now R_m and R_{sh} are connected in parallel, the equivalent resistance is

$$R = \frac{R_{sh} \times R_m}{R_{sh} + R_m} = \frac{0.001 \times 10}{0.001 + 10} = 0.00099 \Omega$$

$$\text{Power dissipation } P = I^2 R = 100^2 \times 0.00099 = 9.9 \text{ W}$$

(b) The series resistance corresponds to 1000 V,

$$R_{sc} = (m-1)R_m, \text{ where } m = \frac{V}{v} = \frac{1000}{100 \times 10^{-3}} = 10^4$$

$$= (10^4 - 1) \times 10 = 99,990 \Omega$$

Now R_m and R_{sc} are connected in series, the equivalent resistance is

$$R = R_{sh} + R_m = 99,990 + 10 = 100,000 \Omega$$

$$\text{Power dissipation } P = V^2 / R = 1000^2 / 100,000 = 10 \text{ W}$$

Example 2.10

A moving-coil instrument has a resistance of 75Ω and gives a full-scale deflection of 100-scale divisions for a current of 1 mA . The instrument is connected in parallel with a shunt of 25Ω resistance and the combination is then connected in series with a load and a supply. What is the current in the load when the instrument gives an indication of 80 scale divisions?

Solution

For 80 scale divisions, current through the meter is $\times 1 = 0.8 \text{ mA}$

Now,

$$I \times \frac{R_{sh}}{R_{sh} + R_m} = 0.8$$

$$I \times \frac{25}{25 + 75} = 0.8$$

$$I = \frac{0.8 \times 100}{25} = 3.2 \text{ mA}$$

So, current through the load is 3.2 mA .

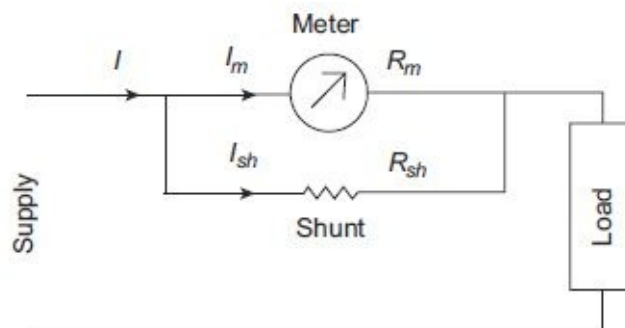

2.8

MOVING-IRON INSTRUMENTS

Basic range: 10 mA-100 A

Usage:

- dc MI ammeters and voltmeters
- ac MI ammeters and voltmeters

Moving-Iron or MI instruments can be classified as

- Attraction-type moving-iron instruments

- Repulsion-type moving-iron instruments

The current to be measured, in general, is passed through a coil of wire in the moving-iron instruments. In case of voltage measurement, the current which is proportional to the voltage is measured. The number of turns of the coil depends upon the current to be passed through it. For operation of the instrument, a certain number of ampere turns is required. These ampere turns can be produced by the product of few turns and large current or reverse.

2.8.1 Attraction-type Moving-Iron Instruments

The attraction type of MI instrument depends on the attraction of an iron vane into a coil carrying current to be measured. Figure 2.14 shows a attraction-type MI instrument. A soft iron vane IV is attached to the moving system. When the current to be measured is passed through the coil C, a magnetic field is produced. This field attracts the eccentrically mounted vane on the spindle towards it. The spindle is supported at the two ends on a pair of jewel bearings. Thus, the pointer PR, which is attached to the spindle S of the moving system is deflected. The pointer moves over a calibrated scale.

The control torque is provided by two hair springs S_1 and S_2 in the same way as for a PMMC instrument; but in such instruments springs are not used to carry any current. Gravity control can also be used for vertically mounted panel type MI meters. The damping torque is provided by the movement of a thin vane V in a closed sector-shaped box B, or simply by a vane attached to the moving system. Eddy current damping can not be used in MI instruments owing to the fact that any permanent magnet that will be required to produce Eddy current damping can distort the otherwise weak operating magnetic field produced by the coil.

If the current in the fixed coil is reversed, the field produced by it also reverses. So the polarity induced on the vane reverses. Thus whatever be the direction of the current in the coil the vane is always be magnetized in such a way that it is attracted into the coil. Hence such instrument can be used for both direct current as well as alternating current.

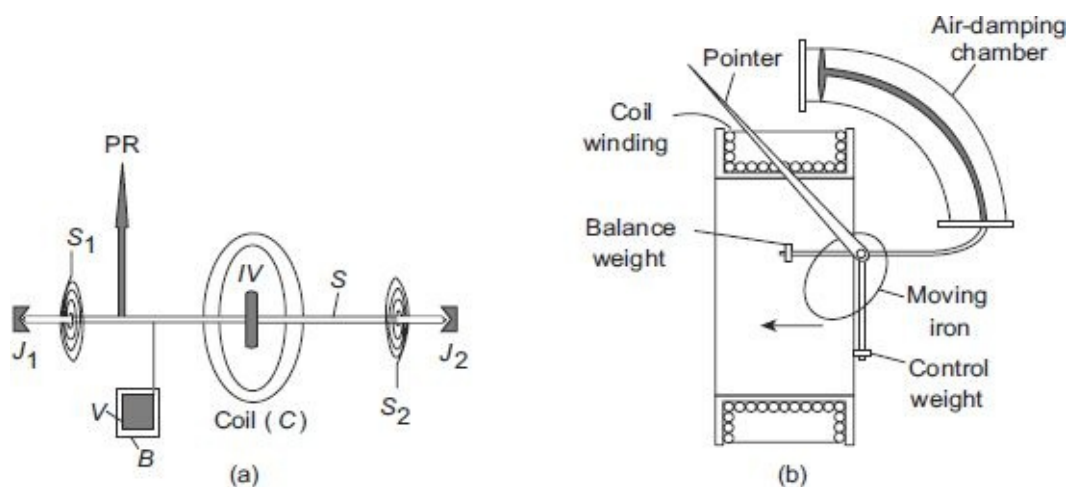

Figure 2.14 Attraction-type moving iron (MI) instrument

2.8.2 Repulsion-type Moving-Iron Instruments

In the repulsion type, there are two vanes inside the coil. One is fixed and the other is movable. These are similarly magnetised when the current flows through the coil and

there is a force of repulsion between the two vanes resulting in the movement of the moving vane.

Two different designs for moving iron instruments commonly used are as follows:

1. Radial Vane Type In this type, the vanes are radial strips of iron. The strips are placed within the coil as shown in Figure 2.15(a). The fixed vane is attached to the coil and the movable one to the spindle of the instrument. The instrument pointer is attached to the moving vane spindle.

As current flows through the coil, the generated magnetic field induces identical polarities on both the fixed and moving vane. Thus, even when the current through the coil is alternating (for AC measurement), there is always a repulsion force acting between the like poles of fixed and moving vane. Hence deflection of the pointer is always in the same direction irrespective of the polarity of current in the coil. The amount of deflection depends on the repulsion force between the vanes which in turn depends on the amount of current passing through the coil. The scale can thus be calibrated to read the current or voltage directly.

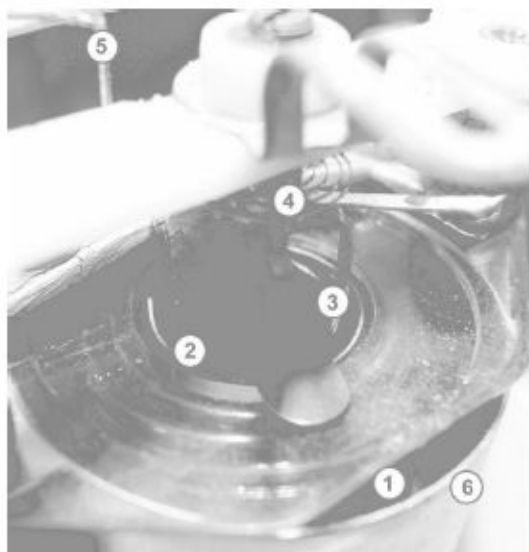
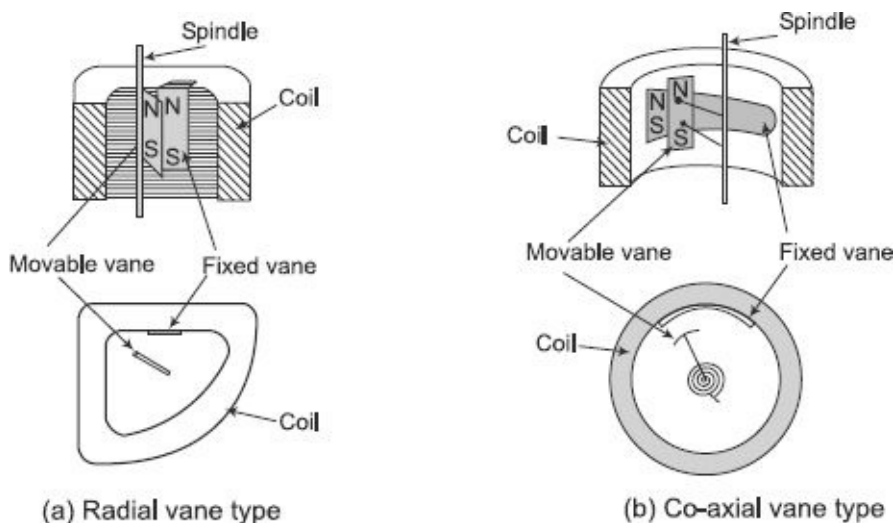

(c) Photograph of a Co-axial vane-type MI instrument

Figure 2.15 Re-pulsion-type Moving Iron (MI) instruments

2. Co-axial Vane Type I In these type of instruments, the fixed and moving vanes are sections of coaxial cylinders as shown in [Figure 2.15\(b\)](#). Current in the coil magnetizes both the vanes with similar polarity. Thus the movable vane rotates along the spindle axis due to this repulsive force. Coaxial vane type instruments are moderately sensitive as compared to radial vane type instruments that are more sensitive.

Moving iron instruments have their deflection is proportional to the square of the current flowing through the coil. These instruments are thus said to follow a square law response and have non-uniform scale marking. Deflection being proportional to square of the current, whatever be the polarity of current in the coil, deflection of a moving iron instrument is in the same direction. Hence, moving iron instruments can be used for both DC and AC measurements.

2.8.3 Torque Equation of Moving-Iron Instruments

To deduce the expression for torque of a moving iron instrument, energy relation can be considered for a small increment in current supplied to the instrument. This result in a small deflection $d\theta$ and some mechanical work will be done. Let T_d be the deflecting torque.

Therefore mechanical work done = torque \times angular displacement

$$= T_d \cdot d\theta \tag{2.27}$$

Due to the change in inductance there will be a change in the energy stored in the magnetic field.

Let I be the initial current, L be the instrument inductance and θ is the deflection. If the current increases by dI then it causes the change in deflection $d\theta$ and the inductance by dL . In order to involve the increment dI in the current, the applied voltage must be increase by:

$$e = \frac{d\phi}{dt} = \frac{d}{dt}(LI) = I \frac{dL}{dt} + L \frac{dI}{dt} \tag{2.28}$$

The electrical energy supplied is $e \, dt = I^2 dL + IL dI$ (2.29)

[substitute the value of $e \, dt$ from equation (2.28)]

The current is changes from I to $(I + dI)$, and the inductor L to $(L + dL)$

Therefore the stored energy changes from $= \frac{1}{2} I^2 L$ to $\frac{1}{2} (I + dI)^2 (L + dL)$

Hence the change in stored energy = $\frac{1}{2} (I + dI)^2 (L + dL) - \frac{1}{2} I^2 L$ (2.30)

As dI and dL are very small, neglecting the second and higher order terms in small quantities, this

becomes $IL dL + \frac{1}{2} I^2 dL$

From the principle of conservation of energy,

Electrical energy supplied = Increase in stored energy + Mechanical work done.

$$I^2 dL + ILdl = ILdl + \frac{1}{2} I^2 dL + T_d d\theta$$

$$\therefore T_d d\theta = \frac{1}{2} I^2 dL \quad (2.31)$$

$$\text{or deflecting torque } T_d = \frac{1}{2} I^2 \frac{dL}{d\theta} \quad (2.32)$$

where T_d is in newton-metre, I is in ampere, L is in henry and θ is in radians.

The moving system is provided with control springs and in turn the deflecting torque T_d is balanced by the controlling torque $T_c = k \theta$

where k is the control spring constant (N-m/rad) and θ is the deflection in radians.

At final steady position, $T_c = T_d$

$$\text{or } k\theta = \frac{1}{2} I^2 \frac{dL}{d\theta}$$

$$\therefore \text{deflection } \theta = \frac{1}{2} \frac{I^2}{k} \frac{dL}{d\theta} \quad (2.33)$$

Hence, the deflection is proportional to square of the rms value of the operating current. The deflection torque is, therefore, unidirectional whatever may be the polarity of the current.

Advantages of MI Instruments

1. Robust construction and relatively cheap
2. Suitable for measuring both dc and ac
3. Can withstand overload momentarily

Disadvantages of MI Instruments

1. As the deflection is proportional to I^2 , hence the scale of the instrument is not uniform. It is cramped in the lower end and expanded in the upper portion.
2. It is affected by stray magnetic fields.
3. There is hysteresis error in the instrument. The hysteresis error may be minimized by using the vanes of nickel-iron alloy.
4. When used for measuring ac the reading may be affected by variation of frequency due to the change in reactance of the coil, which has some inductance. With the increase in frequency iron losses and coil impedance increases.
5. Since large amount of power is consumed to supply I^2R loss in the coil and magnetic losses in the vanes, it is not a very sensitive instrument.

Example 2.11

The inductance of a moving-iron ammeter with a full-scale deflection of 90° at 1.5 A is given by $L = (200 + 40\theta - 4\theta^2 - \theta^3) \mu\text{H}$ where θ is the deflection in radian from the zero position. Estimate the angular deflection of the pointer for a current of 1 A.

Solution For an MI instrument,

$$\text{deflection } \theta = \frac{1}{2} \frac{I^2}{k} \frac{dL}{d\theta}$$

Here, $L = (200 + 40\theta - 4\theta^2 - \theta^3) \mu\text{H}$

Then $\frac{dL}{d\theta} = (40 - 8\theta - 3\theta^2)$

For a deflection, $\theta = 90^\circ = \frac{\pi}{2}$, current $I = 1.5 \text{ A}$

$$\frac{\pi}{2} = \frac{1}{2} \times \frac{(1.5)^2}{k} \times \left[40 - 8\left(\frac{\pi}{2}\right) - 3\left(\frac{\pi}{2}\right)^2 \right]$$

$$k = \frac{(1.5)^2}{\pi} \times \left[40 - 8\left(\frac{\pi}{2}\right) - 3\left(\frac{\pi}{2}\right)^2 \right]$$
$$= 14.348 \text{ N-m/rad}$$

Now for a current of 1 A, the angular deflection θ is

$$\theta = \frac{1}{2} \frac{I^2}{k} \frac{dL}{d\theta}$$

$$\theta = \frac{1}{2} \times \frac{1}{14.348} \times (40 - 8\theta - 3\theta^2)$$

$$40 - 8\theta - 3\theta^2 = 28.696 \theta$$

$$3\theta^2 + 36.696 \theta - 40 = 0$$

After solving for θ and taking only the positive value

$$\theta = 1.00712 \text{ rad} = 57.7^\circ$$

Example 2.12

The law of deflection of a moving-iron ammeter is given by $I = 4\theta^n$ ampere, where θ is the deflection in radian and n is a constant. The self-inductance when the meter current is zero is 10 mH. The spring constant is 0.16 N-m/rad.

- Determine an expression for self-inductance of the meter as a function of θ and n .
- With $n = 0.75$, calculate the meter current and the deflection that corresponds to a self-inductance of 60 mH.

Solution

$$(a) \quad \theta = \frac{1}{2} \frac{I^2}{k} \frac{dL}{d\theta}$$

$$\theta = \frac{1}{2} \times \frac{(4\theta^n)^2}{0.16} \times \frac{dL}{d\theta}$$

$$2\theta \cdot d\theta = 100 \cdot \theta^{2n} dL$$

$$dL = \frac{1}{50} \theta^{1-2n} d\theta$$

Integrating both sides,

$$L = \frac{1}{100} \frac{\theta^{2-2n}}{(1-n)} + C; \quad C = \text{Integration constant}$$

at $I = 0$, i.e. $\theta = 0$, $L = 10 \times 10^{-13}$

Substituting the value of θ and L , we get

$$C = 10 \times 10^{-3}$$

$$\text{So, } L = \frac{1}{100} \frac{\theta^{2-2n}}{(1-n)} + 10 \times 10^{-3}$$

(b) Now $n = 0.75$ and $L = 60 \times 10^{-3}$

$$60 \times 10^{-3} = \frac{1}{100} \frac{\theta^{2-2 \times 0.75}}{(1-0.75)} + 10 \times 10^{-3}$$

$$\theta^{0.5} = 25(60 \times 10^{-3}) = 1250 \times 10^{-3}$$

$$\theta = (1250 \times 10^{-3})^2 = 1.56 \text{ rad} = 89.38 \text{ degree}$$

So meter current $I = 4 \times (1.56)^{0.75} = 5.58 \text{ Amp}$

2.9

ELECTRODYNAMOMETER-TYPE INSTRUMENTS

The electrodynamicometer is a transfer-type instrument. A transfer-type instrument is one that may be calibrated with a dc source and then used without modification to measure ac. This requires the transfer type instruments to have same accuracy for both dc and ac.

The electrodynamic or dynamometer-type instrument is a moving-coil instrument but the magnetic field, in which the coil moves, is provided by two fixed coils rather than by permanent magnets. The schematic diagram of electrodynamic instrument is shown in [Figure 2.16\(a\)](#) and a practical meter is shown in [Figure 2.16\(b\)](#). It consists of two fixed coils, which are symmetrically situated. It would have a torque in one direction during one half of the cycle and an equal effect in opposite direction during the other half of the cycle. If, however, we were to reverse the direction of the flux each time the current through the movable coil reverses, a unidirectional torque would be produced for both positive half and negative half of the cycle. In electrodynamic instruments, the field can be made to reverse simultaneously with the current in the movable coil if the fixed coil is connected in series with the movable coil.

1. Controlling Torque The controlling torque is provided by two control springs. These springs act as leads to the moving coil.

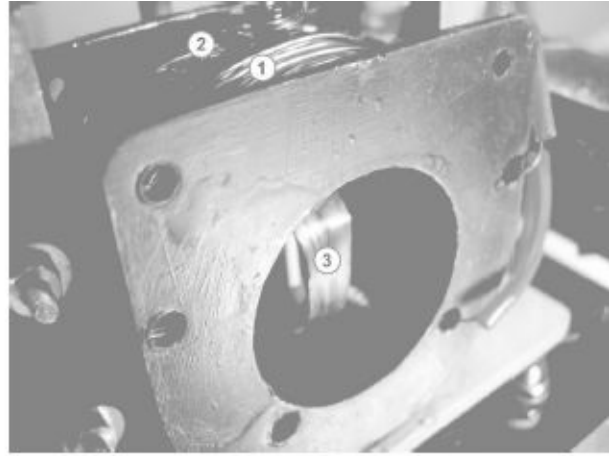
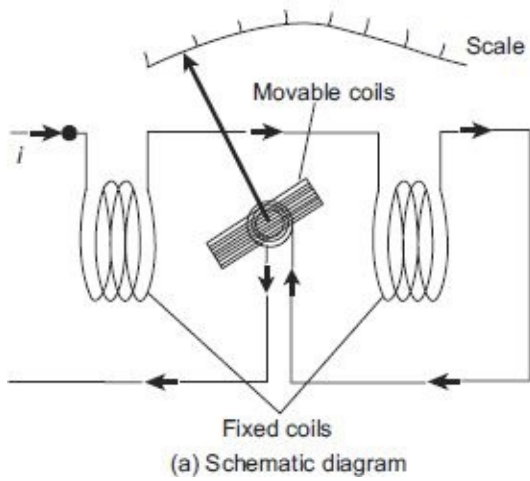

1/ 2. Fixed Coils, 3. Moving Coils
(b) Practical meter

Figure 2.16 Electro-dynamometer-type instrument

2. Damping Air-friction damping is employed for these instruments and is provided by a pair of aluminium vanes, attached to the spindle at the bottom. These vanes move in a sector-shaped chamber.

2.9.1 Torque Equation of Electro-dynamometer-type Instruments

Let, i_1 = instantaneous value of current in the fixed coils, (A)

i_2 = instantaneous value of current in the moving coils, (A)

L_1 = self-inductance of fixed coils, (H)

L_2 = self-inductance of moving coil, (H)

M = mutual inductance between fixed and moving coils (H)

Flux linkage of Coil 1, $\psi_1 = L_1 i_1 + M i_2$

Flux linkage of Coil 2, $\psi_2 = L_2 i_2 + M i_1$

Electrical input energy,

$$= e_1 i_1 dt + e_2 i_2 dt = i_1 d\psi_1 + i_2 d\psi_2$$

$$\text{As } e_1 = \frac{d\psi_1}{dt} \text{ and } e_2 = \frac{d\psi_2}{dt}$$

$$= i_1 d(L_1 i_1 + M i_2) + i_2 d(L_2 i_2 + M i_1)$$

$$= i_1 L_1 di_1 + i_1^2 dL_1 + i_1 i_2 dM + i_1 M di_2 + i_2 L_2 di_2 + i_2^2 dL_2 + i_1 i_2 dM + i_2 M di_1 \quad (2.34)$$

Energy stored in the magnetic field = $\frac{1}{2} i_1^2 L_1 + \frac{1}{2} i_2^2 L_2 + i_1 i_2 M$

Change in energy stored = $d\left(\frac{1}{2} i_1^2 L_1 + \frac{1}{2} i_2^2 L_2 + i_1 i_2 M\right)$

$$= i_1 L_1 di_1 + \frac{1}{2} i_1^2 dL_1 + i_2 L_2 di_2 + \frac{1}{2} i_2^2 dL_2 + i_1 M di_2 + i_2 M di_1 + i_1 i_2 dM \quad (2.35)$$

From the principle of conservation of energy,

Total electrical input energy = Change in energy in energy stored + mechanical energy
 The mechanical energy can be obtained by subtracting Eq. (2.35) from Eq. (2.34).

$$\text{Therefore, mechanical energy} = \frac{1}{2}i_1^2 dL_1 + \frac{1}{2}i_2^2 dL_2 + i_1 i_2 dM$$

Now, the self-inductances L_1 and L_2 are constants and, therefore, dL_1 and dL_2 both are equal to zero. Hence, mechanical energy = $i_1 i_2 dM$

Suppose T_i is the instantaneous deflecting torque and $d\theta$ is the change in deflection, then, Mechanical energy = work done = $T_i d\theta$

Thus we have

$$T_i d\theta = i_1 i_2 dM \quad \text{or} \quad T_i = i_1 i_2 \frac{dM}{d\theta} \quad (2.36)$$

1. Operation with dc Let, I_1 = current in the fixed coils, I_2 = current in the moving coil

So deflecting torque $T_d = I_1 I_2 \frac{dM}{d\theta}$. This shows that the deflecting torque depends in general on the product of current I_1 and I_2 and the rate of change of mutual inductance.

This deflecting torque deflects the moving coil to such a position where the controlling torque of the spring is equal to the deflecting torque. Suppose θ be the final steady deflection.

Therefore controlling torque $T_c = k\theta$ where k = spring constant (N-m/rad)

At final steady position $T_d = T_c$

$$I_1 I_2 \frac{dM}{d\theta} = k\theta$$

$$\text{or, the deflection } \theta = \frac{I_1 I_2}{k} \frac{dM}{d\theta} \quad (2.37)$$

If the two coils are connected in series for measurement of current, the two currents I_1 and I_2 are equal.

Say, $I_1 = I_2 = I$

Thus, deflection of the pointer is $\theta = \frac{I^2}{k} \frac{dM}{d\theta}$

For dc use, the deflection is thus proportional to square of the current and hence the scale non-uniform and crowded at the ends.

2. Operation with ac Let, i_1 and i_2 be the instantaneous values of current carried by the coils. Therefore, the instantaneous deflecting torque is:

$$T_i = i_1 i_2 \frac{dM}{d\theta}$$

If the two coils are connected in series for measurement of current, the two instantaneous currents i_1 and i_2 are equal.

Say, $i_1 = i_2 = i$

Thus, instantaneous torque on the pointer is $T_i = i^2 \frac{dM}{d\theta}$

Thus, for ac use, the instantaneous torque is proportional to the square of the instantaneous current. As the quantity i^2 is always positive, the current varies and the instantaneous torque also varies. But the moving system due to its inertia cannot follow such rapid variations in the instantaneous torque and responds only to the average torque.

The average deflecting torque over a complete cycle is given by:

$$T_d = \frac{1}{T} \int_0^T T_i dt = \frac{dM}{d\theta} \frac{1}{T} \int_0^T i^2 dt$$

where T is the time period for one complete cycle.

At final steady position $T_d = T_C$

$$\text{or, } k\theta = \frac{dM}{d\theta} \frac{1}{T} \int_0^T i^2 dt$$

Thus, deflection of the pointer is $\theta = \frac{1}{k} \frac{dM}{d\theta} \frac{1}{T} \int_0^T i^2 dt$

Deflection is thus a function of the mean of the square of the current. If the pointer scale is calibrated in terms of square root of this value, i.e. square root of the mean of the square of current value, then rms value of the ac quantity can be directly measured by this instrument.

3. Sinusoidal Current If currents i_1 and i_2 are sinusoidal and are displaced by a phase angle ϕ , i.e.

$$i_1 = I_{m1} \sin \omega t \text{ and } i_2 = I_{m1} \sin(\omega t - \phi)$$

\therefore The average deflecting torque

$$T_d = \frac{dM}{d\theta} \frac{1}{T} \int_0^T i_1 i_2 dt = \frac{dM}{d\theta} \frac{1}{2\pi} \int_0^{2\pi} I_{m1} \sin \omega t \cdot I_{m2} \sin(\omega t - \phi) d\omega t$$

$$\frac{I_{m1} I_{m2}}{2} \cos \phi \frac{dM}{d\theta} = I_1 I_2 \cos \phi \frac{dM}{d\theta}$$

where I_1 and I_2 are the rms values of the currents flowing through the coils. At equilibrium, $T_d = T_C$

$$\text{or } I_1 I_2 \cos \phi \frac{dM}{d\theta} = k\theta \quad (2.38)$$

$$\therefore \theta = \frac{I_1 I_2 \cos \phi}{k} \frac{dM}{d\theta}$$

As was in the case with ac measurement, with sinusoidal current also the deflection is a function of the mean of the square of the current. If the pointer scale is calibrated in terms of square root of this value, i.e. square root of the mean of the square of current value, then RMS value of the ac quantity can be directly measured by this instrument.

1. Electrodynamic Ammeter In an electrodynamic ammeter, the fixed and moving coils are connected in series as shown in Figure 2.17. A shunt is connected across the moving coil for limiting the current. The reactance–resistance ratio of the shunt and the moving coil is kept nearly same for independence of the meter reading with the supply frequency. Since the coil currents are the same, the deflecting torque is proportional to the mean square value of the current. Thus, the scale is calibrated to read the rms value.

2. Electrodynamic Voltmeter The electrodynamic instrument can be used as a voltmeter by connecting a large noninductive resistance (R) of low temperature coefficient in series with the instrument coil as shown in Figure 2.18.

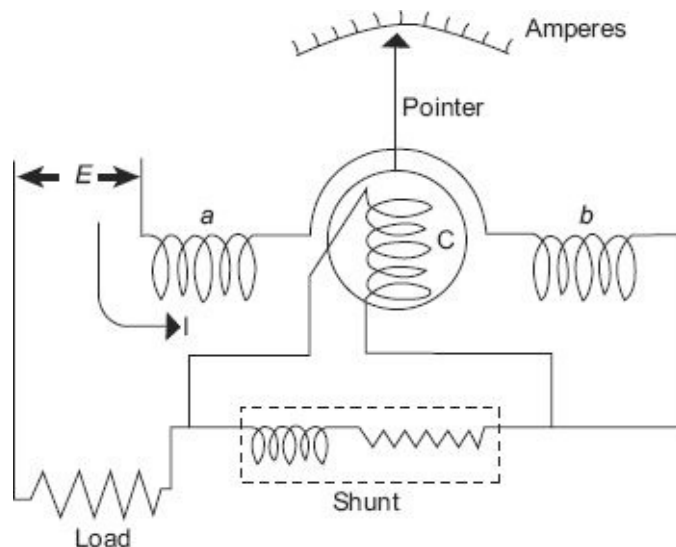

Figure 2.17 Electrodynamic ammeter

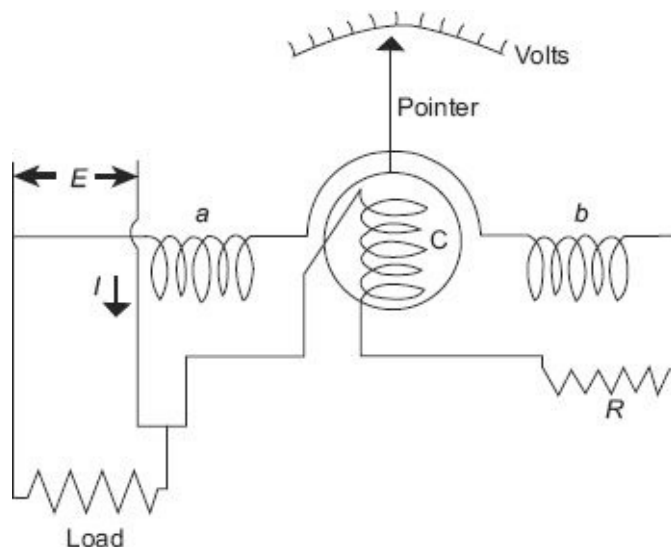

Figure 2.18 Electrodynamic voltmeter

3. Electrodynamic Wattmeter The electrodynamic wattmeter consist of two fixed coils ‘a’ and ‘b’ placed symmetrical to each other and producing a uniform magnetic field. They are connected in series with the load and are called the Current Coils (CC). The two fixed coils can be connected in series or parallel to give two different current ratings. The

current coils carry the full-load current or a fraction of full load current. Thus the current in the current coils is proportional to the load current. The moving coil 'c', in series with a high non inductive resistance R_v is connected across the supply. Thus the current flowing in the moving coil is proportional to, and practically in phase with the supply voltage. The moving coil is also called the voltage coil or Pressure Coil (PC). The voltage coil is carried on a pivoted spindle which carries the pointer, the pointer moved over a calibrated scale.

Two hair springs are used for providing the controlling torque and for leading current into and out of the moving coil. Damping is provided by air friction. Figure 2.20 shows the basic arrangement of a electrodynamic wattmeter.

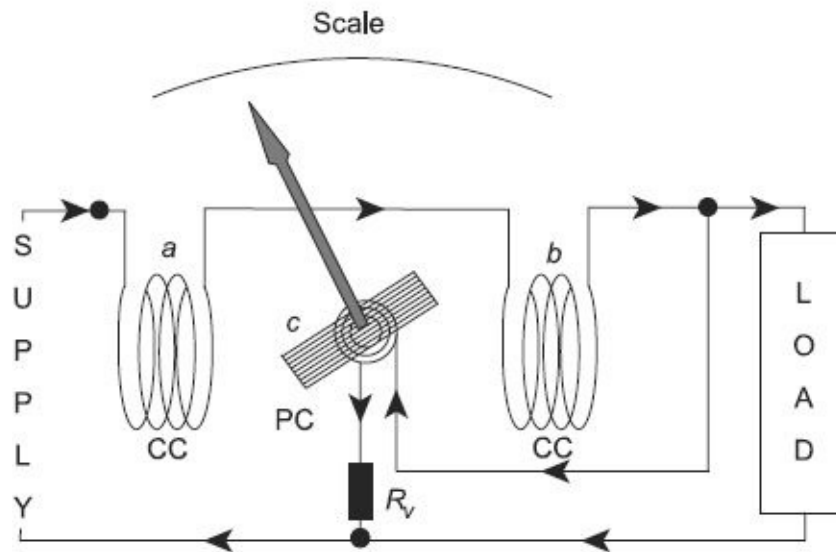

Figure 2.19 Electrodynamic wattmeter

4. Torque Equation

Let, i_f = current in the fixed coil

i_m = current in the moving coil

i = load current

v = load voltage

T_{in} = instantaneous value of the deflecting torque

p = instantaneous power

$$T_{in} \propto i_f i_m$$

$$T_{in} \propto i_f i_m \tag{2.39}$$

But since $i_f \propto i$ and $i_m \propto v$

$$T_{in} \propto vi \propto p \tag{2.40}$$

Thus, the instantaneous value of the deflecting torque is proportional to the instantaneous power. Owing to the inertia of the moving system, the pointer reads the average power. In dc circuits, the power is given by the product of voltage and current, and hence the torque is directly proportional to the power. Thus, the instrument indicates the power.

For ac, the instrument indicates the average power. This can be proved as follows:

$$T_{in} \propto V_i$$

Average deflecting torque \times average power

Let, $v = V_m \sin d$

$$I = I_m \sin (\theta - \Phi)$$

Average deflecting torque \propto average value of $V_m \sin d \times I_m \sin (\theta - \Phi) \propto VI \cos \theta$ If T_d be the average torque, then

$$T_d \propto VI \cos \Phi \propto \text{true power} = kP \quad (2.41)$$

where P is the true power and k is the constant.

For spring control $T_C = k_s \theta_1$

where T_C is the control torque, k_s is the spring constant and θ_1 is the angle of deflection of the pointer.

For steady deflection,

$$\begin{aligned} T_c &= T_d \\ k_s \theta_1 &= kP \\ \theta_1 &= \frac{k}{k_s} P \\ \theta_1 &\propto P \end{aligned}$$

Hence, in case of ac also the deflection is proportional to the true power in the circuit. The scale of the electrodynamicometer wattmeter is therefore uniform.

Advantages of Electrodynamicometer-type Instruments

1. They can be used on ac as well as dc measurements.
2. These instruments are free from eddy current and hysteresis error.
3. Electrodynamicometer-type instruments are very useful for accurate measurement of rms values of voltages irrespective of waveforms.
4. Because of precision grade accuracy and same calibration for ac and dc measurements these instruments are useful as transfer type and calibration instruments.

Disadvantages of Electrodynamicometer-type Instruments

1. As the instrument has square law response, the scale is non-uniform.
2. These instruments have small torque/weight ratio, so the frictional error is considerable.
3. More costly than PMMC and MI type of instruments.
4. Adequate screening of the movements against stray magnetic fields is essential.
5. Power consumption is comparably high because of their construction.

The inductance of a 25 A electrodynamic ammeter changes uniformly at the rate of 0.0035 mH/radian. The spring

Example 2.13

constant is 10^{-6} N-m/radian. Determine the angular deflection at full scale.

Solution $\frac{dM}{d\theta} = 0.0035 \times 10^{-6}$ H/rad

Now the deflection $\theta = \frac{I^2}{k} \frac{dM}{d\theta}$

Angular deflection at full scale current of $I = 25$ A is given by:

$$\theta = \frac{25^2}{10^{-6}} \times 0.0035 \times 10^{-6} \times \frac{180^\circ}{\pi} = 125^\circ$$

In an electrodynamic instrument the total resistance of the voltage coil circuit is 8200Ω and the mutual inductance changes uniformly from $-173 \mu\text{H}$ at zero deflection to $+175 \mu\text{H}$ at full scale. The angle of full scale being 95° . If a potential difference of 100 V is applied across the voltage circuit and a current of 3 A at a power factor of 0.75 is passed through the current coil, what will be the deflection. Spring constant of the instrument is 4.63×10^{-6} N-m/rad.

Example 2.14

Solution Change in mutual inductance $dM = 175 - (-173) = 348 \mu\text{H}$

Deflection $\theta = 95^\circ = 1.66$ rad

Rate of change of mutual inductance

$$\frac{dM}{d\theta} = \frac{348}{1.66} = 209.63 \mu\text{H/rad}$$

Current through the current coil $I_1 = 3$ A

Current through the voltage coil $I_2 = \frac{100}{8200} = 0.0122$ A

Power factor $\cos \phi = 0.75$

Deflection $\theta = \frac{I_1 I_2}{k} \cos \phi \frac{dM}{d\theta}$

$$\begin{aligned} \theta &= \frac{3 \times 0.0122}{4.63 \times 10^{-6}} \times 0.75 \times 209.63 \times 10^{-6} \\ &= 1.242 \text{ rad} = 71.2^\circ \end{aligned}$$

A 50 V range spring-controlled electrodynamic voltmeter has an initial inductance of 0.25 H, the full scale deflection torque of 0.4×10^{-4} Nm and full scale deflection current of 50 mA. Determine the difference between dc and 50 Hz ac reading at 50 volts if the voltmeter inductance increases uniformly over the full scale of 90° .

Example 2.15

Solution

Full-scale deflection $\theta = 90^\circ$

Full-scale deflecting torque, $T_d = 0.4 \times 10^{-4}$ Nm

Full-scale deflection current, $I = 50$ mA = 0.05 A

Initial inductance, $M = 0.25$ H

Since deflecting torque, $T_d = I^2 \frac{dM}{d\theta}$

So for full-scale deflection $0.4 \times 10^{-4} = (0.05)^2 \frac{dM}{d\theta}$

or, $\frac{dM}{d\theta} = \frac{0.4 \times 10^{-4}}{(0.05)^2} = 0.016$ H/rad

Total change in inductance for full-scale deflection,

$$dM = 0.016 \times 90 \times \frac{\pi}{180} = 0.0251 \text{ H}$$

Total mutual inductance, $M = 0.25 + 0.0251 = 0.2751$ H

The resistance of voltmeter, $R = \frac{\text{Voltage}}{\text{Current}} = \frac{50}{0.05} = 1000 \Omega$

The impedance while measuring the voltage of 50 V at 50 Hz AC

$$Z = \sqrt{(1000)^2 + (2\pi \times 50 \times 0.2751)^2} = 1004 \Omega$$

And voltmeter reading, $= \frac{50}{1004} \times 1000 = 49.8$ V

Therefore, difference in reading = $50 - 49.8 = 0.2$ V

2.10

ELECTROSTATIC INSTRUMENTS

In electrostatic instruments, the deflecting torque is produced by action of electric field on charged conductors. Such instruments are essentially voltmeters, but they may be used with the help of external components to measure the current and power. Their greatest use in the laboratory is for measurement of high voltages.

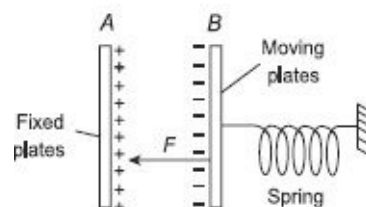

Figure 2.20 Linear motion of electrostatic instruments

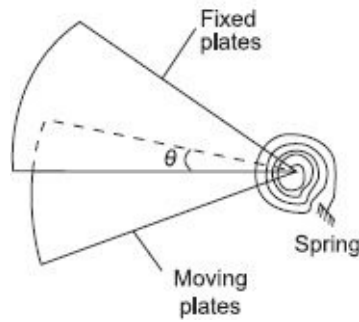

Figure 2.21 Rotary motion of electrostatic instruments

Rotary motion of electrostatic instruments

There are two ways in which the force acts:

1. One type involves two oppositely charged electrodes. One of them is fixed and the other is movable. Due to force of attraction, the movable electrode is drawn towards the fixed one.
2. In the other type, there is force of attraction or repulsion between the electrodes which causes rotary motion of the moving electrode.

In both the cases, the mechanism resembles a variable capacitor and the force or torque is due to the fact that the mechanism tends to move the moving electrode to such a position where the energy stored is maximum.

2.10.1 Force and Torque Equation

1. Linear Motion Referring to [Figure 2.20](#), plate *A* is fixed and *B* is movable. The plates are oppositely charged and are restrained by a spring connected to the fixed point. Let a potential difference of *V* volt be applied to the plates; then a force of attraction *F* Newton exists between them. Plate *B* moves towards *A* until the force is balanced by the spring. The capacitance between the plates is then *C* farad and the stored energy is $\frac{1}{2} CV^2$ joules.

Now let there be a small increment *dV* in the applied voltage, then the plate *B* moves a small distance *dx* towards *A*. when the voltage is being increased a capacitive current flows. This current is given by

$$i = \frac{dq}{dt} = \frac{d}{dt}(CV) = C \frac{dV}{dt} + V \frac{dC}{dt} \quad (2.42)$$

The input energy is $Vidt = V^2 dC + CVdV$ (2.43)

$$\begin{aligned} \text{Change in stored energy} &= \frac{1}{2}(C + dC)(V + dV)^2 - \frac{1}{2}CV^2 \\ &= \frac{1}{2}V^2 dC + CVdV \end{aligned} \quad (2.44)$$

(neglecting the higher order terms as they are small quantities)

From the principle of conservation of energy,

Input electrical energy = increase in stored energy + mechanical work done

$$V^2 dC + CVdV = \frac{1}{2} V^2 dC + CVdV + Fdx$$

$$\therefore \boxed{F = \frac{1}{2} V^2 \frac{dC}{dx}} \quad (2.45)$$

2. Rotational Motion The forgoing treatment can be applied to the rotational motion by writing an angular displacement θ in place of linear displacement x and deflecting torque T_d instead of force F (Figure 2.21).

$$\text{Deflecting torque } T_d = \frac{1}{2} V^2 \frac{dC}{d\theta} \quad (2.46)$$

If the instrument is spring controlled or has a suspension then

Controlling torque $T_c = k\theta$, where k = spring constant

θ = deflection

Hence, deflection

$$\boxed{\theta = \frac{1}{2} \frac{V^2}{k} \frac{dC}{d\theta}} \quad (2.47)$$

Since the deflection is proportional to the square of the voltage to be measured, the instrument can be used on both ac and dc. The instrument exhibits a square law response and hence the scale is non-uniform.

Advantages of Electrostatic Instrumentss

1. These instruments draws negligible amount of power from the mains.
2. They may be used on both ac and dc.
3. They have no frequency and waveform errors as the deflection is proportional to square of voltage and there is no hysteresis.
4. There are no errors caused by the stray magnetic field as the instrument works on the electrostatic principle.
5. They are particularly suited for high voltage.

Disadvantages of Electrostatic Instruments

1. The use of electrostatic instruments is limited to certain special applications, particularly in ac circuits of relatively high voltage, where the current drawn by other instruments would result in erroneous indication. A protective resistor is generally used in series with the instrument in order to limit the current in case of a short circuit between plates.
2. These instruments are expensive, large in size and are not robust in construction.
3. Their scale is not uniform.
4. The operating force is small.

2.11

INDUCTION-TYPE INSTRUMENTS

Induction-type instruments are used only for ac measurement and can be used either as ammeter, voltmeter or wattmeter. However, the induction principle finds its widest

application as a watt-hour or energy meter (for details, refer [Chapter 8](#)). In such instruments, the deflecting torque is produced due to the reaction between the flux of an ac magnet and the eddy currents induced by another flux.

2.11.1 Principle of Operation

The operations of induction-type instruments depend on the production of torque due to the interaction between a flux Φ_1 (whose magnitude depends on the current or voltage to be measured) and eddy current induced in a metal disc or drum by another flux Φ_2 (whose magnitude also depends on the current or voltage to be measured). Since the magnitude of eddy current also depends on the flux producing them, the instantaneous value of the torque is proportional to the square of current or voltage under measurement and the value of mean torque is proportional to the mean square value of this current or voltage.

Consider a thin aluminium or copper disc D free to rotate about an axis passing through its centre as shown in [Figure 2.22](#). Two electromagnets P_1 and P_2 produce alternating fluxes Φ_1 and Φ_2 respectively which cuts this disc. Consider any annular portion of the disc around P_1 with centre of the axis of P_1 . This portion will be linked by flux Φ_1 and so an alternating emf Φ_1 be induced in it. Φ_2 will induce an emf e_2 which will further induce an eddy current i_2 in an annular portion of the disc around P_1 . This eddy currents i_2 flows under the pole P_1 .

Let us take the downward directions of fluxes as positive and further assume that at the instant under consideration, both Φ_1 and Φ_2 are increasing. By applying Lenz's law, the direction of the induced currents i_1 and i_2 can be found as indicated in [Figure 2.22\(b\)](#).

The portion of the disc which is traversed by flux Φ_1 and carries eddy currents i_2 experiences a force F_1 along the direction as indicated. As $F = Bil$, force $F_1 \propto \Phi_1 i_2$. Similarly, the portion of the disc lying under flux Φ_2 and carrying eddy current i_1 experiences a force $\Phi_2 \propto F_2 i_1$.

$$\therefore F_1 \propto \Phi_1 i_2 = k \Phi_1 i_2 \quad (2.48)$$

$$F_2 \propto \Phi_2 i_1 = k \Phi_2 i_1 \quad (2.49)$$

It is assumed that the constant k is the same in both the cases due to the symmetrical position of P_1 and P_2 with respect to the disc.

If r be the effective radius at which these forces acts, then net instantaneous torque T acting on the disc being equal to the different of the two torques, it is given by

$$T = r(k\Phi_1 i_2 - k\Phi_2 i_1) = k_1(\Phi_1 i_2 - \Phi_2 i_1) \quad (2.50)$$

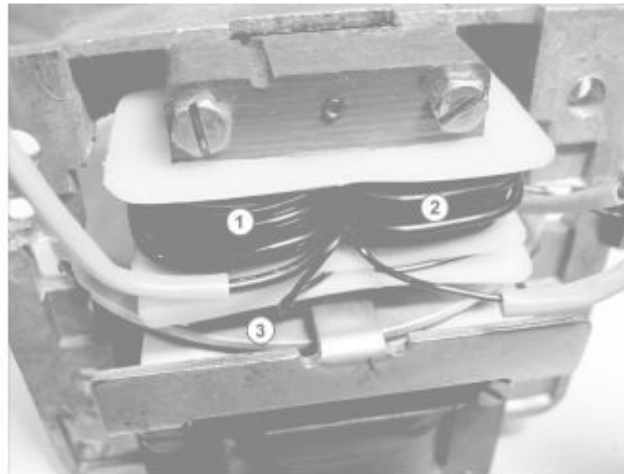
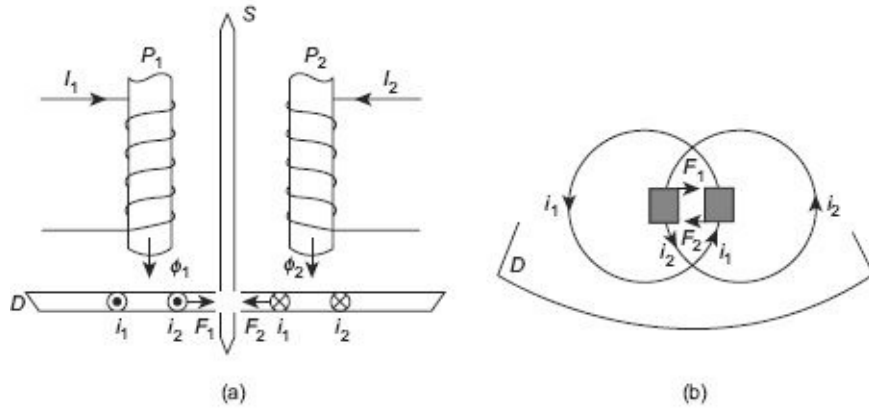

1/2 - Electromagnetic coils, 3 - Aluminium rotating disc

(c) Photograph of Induction type instrument

Figure 2.22 Principle of operation of induction-type instrument

Let the alternating flux ϕ_1 be given by $\phi_1 = \phi_{1m} \sin \omega t$. The flux ϕ_2 which is assumed to lag ϕ_1 by an angle α radian is given by $\phi_2 = \phi_{2m} \sin (\omega t - \alpha)$

$$\text{Induced emf } e_1 = \frac{d\phi_1}{dt} = \frac{d}{dt} (\phi_{1m} \sin \omega t) = \omega \phi_{1m} \cos \omega t$$

Assuming the eddy current path to be purely resistive and of value R , then the value of eddy current is

$$i_1 = \frac{e_1}{R} = \frac{\omega \phi_{1m}}{R} \cos \omega t$$

$$\text{similarly, } e_2 = \omega \phi_{2m} \cos(\omega t - \alpha) \text{ and } i_2 = \frac{e_2}{R} = \frac{\omega \phi_{2m}}{R} \cos(\omega t - \alpha)$$

Substituting these values of i_1 and i_2 in Eq. (2.48), we get k_w

$$\begin{aligned} T &= \frac{k_1 \omega}{R} [\phi_{1m} \sin \omega t \cdot \phi_{2m} \cos(\omega t - \alpha) - \phi_{2m} \sin(\omega t - \alpha) \cdot \phi_{1m} \cos \omega t] \\ &= \frac{k_1 \omega}{R} \phi_{1m} \phi_{2m} [\sin \omega t \cdot \cos(\omega t - \alpha) - \sin(\omega t - \alpha) \cdot \cos \omega t] \\ &= \frac{k_1 \omega}{R} \phi_{1m} \phi_{2m} \sin \alpha = k_2 \omega \phi_{1m} \phi_{2m} \sin \alpha \quad \left[\text{putting } \frac{k_1}{R} = k_2 \right] \end{aligned} \quad (2.51)$$

The following is observed:

1. If $\alpha = 0$, i.e., if two fluxes are in phase, then net torque is zero. If, on the other hand, $\alpha = 90^\circ$, the net torque is maximum for a given values of ϕ_{1m} and ϕ_{2m} .

2. The net torque is such a direction as to rotate the disc from the pole with leading flux, towards the pole with lagging flux.
3. Since the expression for torque does not involve t , it is independent of time, i.e., it has a steady value at all times.
4. The torque T is inversely proportional to R ; the resistance of the eddy current path. Hence, it is made of copper or more often, of aluminium.

2.12

ELECTROTHERMAL INSTRUMENTS

Mainly there are two types of thermal instruments:

- Hot-wire type
- Thermocouple instrument

Hot-wire and thermocouple meter movements use the heating effect of current flowing through a resistance to cause meter deflection. Each uses this effect in a different manner. Since their operation depend only on the heating effect of current flow, they may be used to measure both direct and alternating currents of any frequency on a single scale.

2.12.1 Hot-wire Instrument

The hot-wire meter movement deflection depends on the expansion of a high resistance wire caused by the heating effect of the wire itself as current flows through it. A resistance wire is stretched between the two meter terminals, with a thread attached at a right angles to the centre of the wire. A spring connected to the opposite end of the thread exerts a constant tension on the resistance wire. Current flow heats the wire, causing it to expand. This motion is transferred to the meter pointer through the thread and a pivot. [Figure 2.23](#) shows the basic arrangement of a hot wire type instrument.

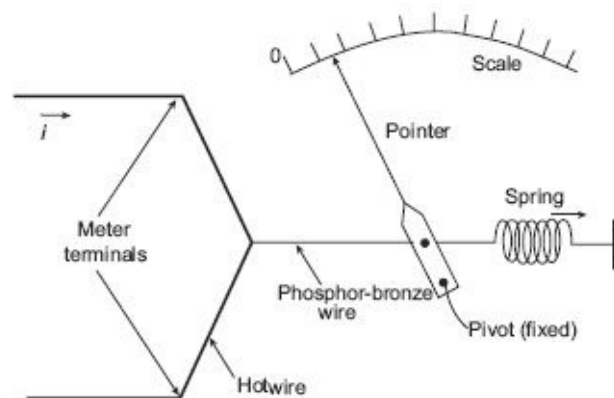

Figure 2.23 Hot-wire instruments

Advantages of Hot-wire-type Instruments

1. The deflection depends upon only the rms value of the current flowing through the wire, irrespective of its waveform and frequency. Hence, the instrument can be used for ac as well as dc system.
2. The calibration is same for ac as well as dc measurement. So it is a transfer-type instrument.
3. They are free from stray magnetic fields because no magnetic field is used to cause their operation.
4. It is cheap in cost and simple in construction.
5. With suitable adjustments, error due to temperature variation can be made negligible.

6. This type of instruments are quite suitable for very high frequency measurement.

Disadvantages of Hot-wire-type Instruments

1. Power consumption is relatively high.
2. Nonuniform scale.
3. These are very sluggish in action as time is taken in heating up the wire.
4. The deflection of the instrument is not the same for ascending and descending values.
5. The reading depends upon the atmospheric temperature.

2.12.2 Thermocouple-Type Instrument

When two metals having different work functions are placed together, a voltage is generated at the junction which is nearly proportional to the temperature of the junction. This junction is called a thermocouple. This principle is used to convert heat energy to electrical energy at the junction of two conductors as shown in [Figure 2.24](#).

The heat at the junction is produced by the electrical current flowing in the heater element while the thermocouple produces an emf at its output terminals, which can be measured with the help of a PMMC meter. The emf produced is proportional to the temperature and hence to the rms value of the current. Therefore, the scale of the PMMC instrument can be calibrated to read the current passing through the heater. The thermocouple type of instrument can be used for both ac and dc applications. The most effective feature of a thermocouple instrument is that they can be used for measurement of current and voltages at very high frequency. In fact, these instruments are very accurate well above a frequency of 50 MHz.

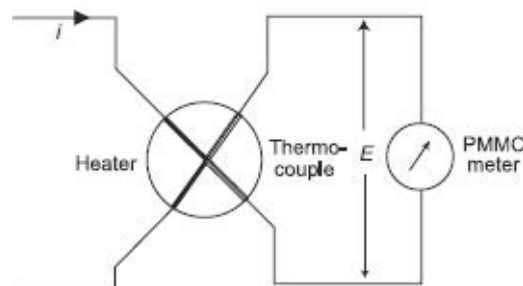

Figure 2.24 Circuit diagram of thermocouple instrument

Advantages of Thermocouple-type Instruments

1. These are not affected by stray magnetic fields.
2. They have very high sensitivity.
3. The indication of these instruments are practically unaffected by the frequency and waveform of the measuring quantity. Hence these instruments can be used for measurement of currents upto frequencies of 50 MHz and give accuracy as high as 1%.
4. These instruments are very useful as transfer instruments for calibration of dc instruments by potentiometer and a standard cell.

Disadvantages of Thermocouple-Type Instruments

1. Considerable power losses due to poor efficiency of thermal conversion.

2. Low accuracy of measurement and sensitivity to overloads, as the heater operates at temperatures close to the limit values. Thus, the overload capacity of such instrument is approximately 1.5 times of full-scale current.
3. The multi-voltmeters used with thermo-elements must be necessarily more sensitive and delicate than those used with shunts, and therefore, requires careful handling.

2.13

RECTIFIER-TYPE INSTRUMENTS

The basic arrangement of a rectifier type of instrument using a full-wave rectifier circuit is shown in Figure 2.25. If this instrument is used for measuring ac quantity then first the ac signal is converted to dc with the help of the rectifier. Then this dc signal is measured by the PMMC meter. The multiplier resistance R_s , is used to limit the value of the current in order that it does not exceed the current rating of the PMMC meter.

These types of instruments are used for light current work where the voltage is low and resistances high.

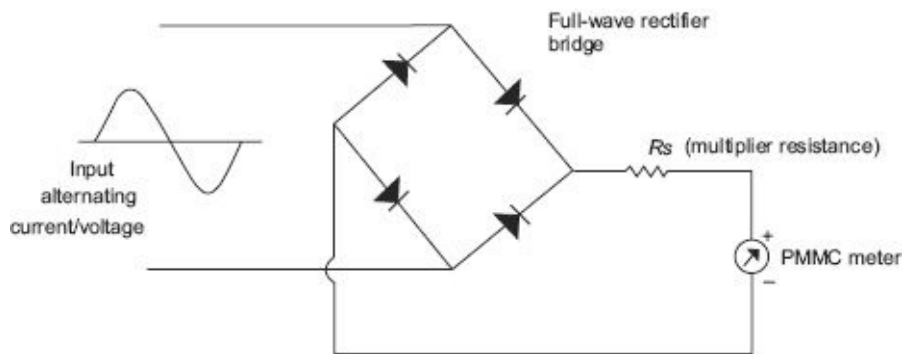

Figure 2.25 Rectifier-type instrument

2.13.1 Sensitivity of Rectifier-Type Instrument

The dc sensitivity of a rectifier-type instrument is

$$S_{dc} = \frac{1}{I_{fs}} \Omega/v \text{ where } I_{fs} \text{ is the current required to produce full-scale deflection.}$$

1. Sensitivity of a Half-wave Rectifier Circuit

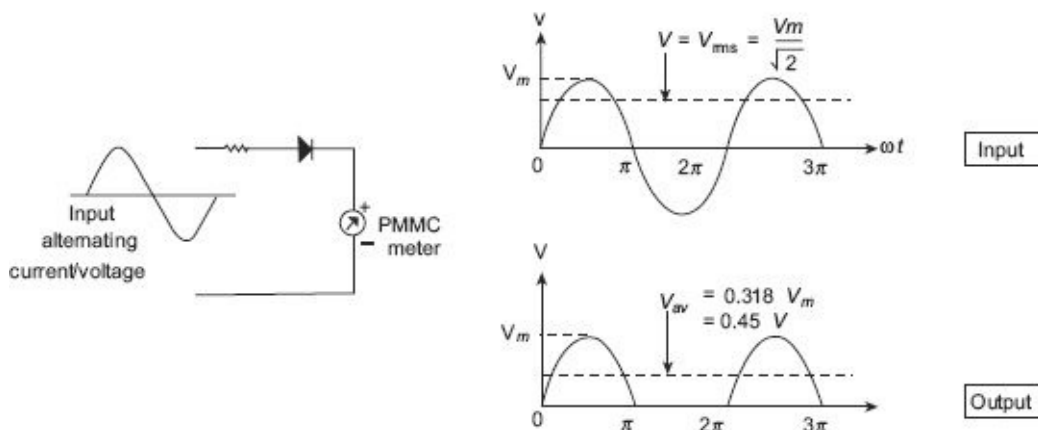

Figure 2.26 Half-wave rectifier

Figure 2.26 shows a simple half-wave rectifier circuit along with the input and output

waveform. The average value of voltage/current for half-wave rectifier,

$$V_{av} = \frac{1}{2\pi} \int_0^{\pi} V_m \sin \omega t \, d\omega t = \frac{V_m}{\pi} = 0.318V_m = 0.45 \text{ V} \quad (2.52)$$

Hence, the sensitivity of a half-wave rectifier instrument with ac is 0.45 times its sensitivity with dc and the deflection is 0.45 times that produces with dc of equal magnitude V.

$$S_{ac} = 0.45S_{dc} \quad (2.53)$$

2. Sensitivity of a Full-wave Rectifier Circuits

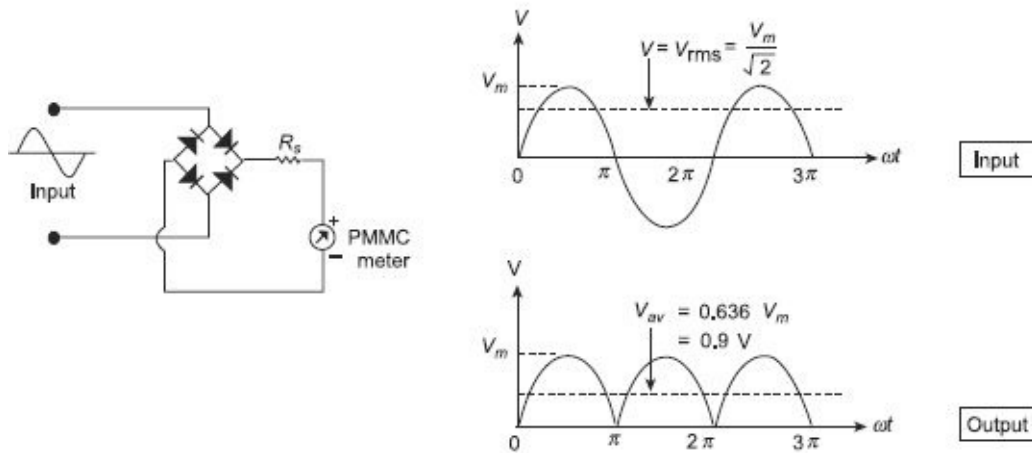

Figure 2.27 Full-wave rectifier

Figure 2.27 Full-wave rectifier

Figure 2.27 shows a full-wave rectifier circuit along with the input and output waveform. Average value of voltage/current for full-wave rectifier,

$$V_{av} = \frac{1}{\pi} \int_0^{\pi} V_m \sin \omega t \, d\omega t = \frac{2V_m}{\pi} = 0.636V_m = 0.9 \text{ V} \quad (2.54)$$

So the deflection is 0.9 times in a full-wave rectifier instrument with an ac than that produced with dc of equal magnitude V.

Sensitivity of a full-wave rectifier instrument with an ac is 0.9 times its sensitivity with dc.

$$S_{ac} = 0.9S_{dc} \quad (2.55)$$

2.13.2 Extension of Range of Rectifier Instrument as Voltmeter

Suppose it is intended to extend the range of a rectifier instrument which uses a PMMC instrument having a dc sensitivity of S_{dc} .

Let, v = voltage drop across the PMMC instrument

V = applied voltage

Therefore, for dc operation, the values of series resistance (multiplier) needed can be calculated from Figure 2.28 as

$$V = R_S \cdot I_{fs} + R_d \cdot I_{fs} + R_m \cdot I_{fs}$$

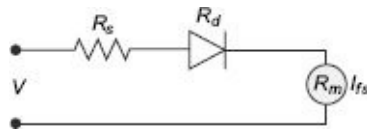

Figure 2.28 Range extension of rectifier voltmeter

$$\begin{aligned}
 R_s &= \left(\frac{V}{I_{fs}} \right) - R_m - R_d \\
 &= S_{dc}V - R_m - R_d \text{ (for half-wave rectification)} \\
 &= S_{dc}V - R_m - 2R_d \text{ (for full-wave rectification)}
 \end{aligned}
 \tag{2.56}$$

where R_m = meter resistance

R_d = diode forward resistance

For ac voltmeter,

$$\begin{aligned}
 R_s &= S_{ac}V - R_m - R_d = 0.45S_{dc}V - R_m - R_d \text{ (for half-wave)} \\
 &= S_{ac}V - R_m - 2R_d = 0.9S_{dc}V - R_m - R_d \text{ (for full-wave)}
 \end{aligned}
 \tag{2.57}$$

Limitations

1. Rectifier instruments are only accurate on the waveforms on which they are calibrated. Since calibration assumes pure sine waves, the presence of harmonics gives erroneous readings.
2. The rectifier is temperature sensitive, and therefore, the instrument readings are affected by large variations of temperature.

Applications

1. The rectifier instrument is very suitable for measuring alternating voltages in the range of 50–250 V.
2. The rectifier instrument may be used as a micrometer or low milliammeter (up to 10–15 mA). It is not suitable for measuring large currents because for larger currents the rectifier becomes too bulky and providing shunts is impracticable due to rectifier characteristics.
3. Rectifier instruments find their principal application in measurement in high-impedance circuits at low and audio frequencies. They are commonly used in communications circuits because of their high sensitivity and low power consumption.

2.14

TRUE rms VOLTMETER

The commonly available multimeters are average or peak reading instruments, and the rms values they display are based on the signal mean value. They multiply the average value with some factor to convert it to the rms reading. For this reason, conventional multimeters are only suited for sinusoidal signals. For measuring rms value of a variety of signals over a wide range of frequencies, a new kind of voltmeter—called the True RMS (TRMS) voltmeter has been developed. Since these voltmeters do not measure rms value of a signal based on its average value, they are suited for any kind of waveforms (such as sine wave, square wave or sawtooth wave).

The conventional moving-iron voltmeter has its deflection proportional to the square of the current passing through its coil. Thus, if the scale is calibrated in terms of square root of the measured value, moving-iron instruments can give true rms value of any signal,

independent of its wave shape. However, due to large inertia of the mechanical moving parts present in such a moving iron instrument, the frequency bandwidth of such a true rms voltmeter is limited. Similar is the case for electro-dynamometer type instruments which once again have their deflecting torque proportional to the current through their operating coil. But once again, though electro-dynamometer-type instruments can give true rms indication of a signal of any waveform, their frequency bandwidth is also limited due to their mechanical moving parts.

Modern-day true rms reading voltmeters are made to respond directly to the heating value of the input signal. To measure rms value of any arbitrary waveform signal, the input signal is fed to a heating element and a thermocouple is placed very close to it. A thermocouple is a junction of two dissimilar metals whose contact potential is a function of the temperature of the junction. The heating value is proportional to the square of the rms value of the input signal. The heater raises the temperature of the heater and the thermocouple produces an output voltage that is proportional to the power delivered to the heater by the input signal. Power being proportional to the square of the current (or voltage) under measurement, the output voltage of the thermocouple can be properly calibrated to indicate true rms value of the input signal. This way, such a thermal effect instrument permits the determination of true rms value of an unknown signal of any arbitrary waveform. Bandwidth is usually not a problem since this kind of principle can be used accurately even beyond 50 MHz. Figure 2.28 shows such an arrangement of thermocouple based true rms reading voltmeter.

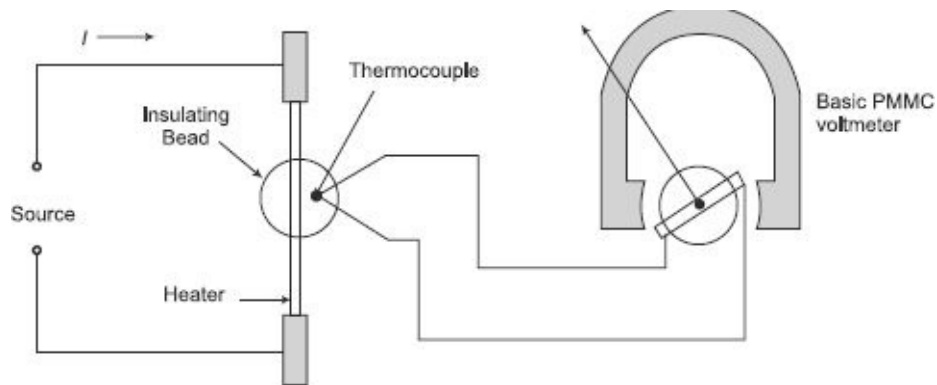

Figure 2.28 Thermocouple based true rms reading voltmeter

Sl. No.	Type of Instruments	Suitability for type of measurement	Type of control	Type of damping	Specialty
1.	Moving Coil (i) PMMC	dc measurement (current and voltage only)	Spring	Eddy current	It is most accurate type for dc measurements and most widely used for measurement of dc voltage, current and resistance.
	(ii) Dynamometer	dc or ac measurement (current, voltage and power)	Spring	Air friction	Mainly used as wattmeter. Also used as standard meter for calibration and as transfer instrument.
2.	Moving Iron	dc or ac measurement (current, voltage)	Spring or gravity control	Air friction	It is cheaper to manufacture and mostly used as an indicating instrument. It is very accurate for ac and dc, if properly designed.
3.	Electrostatic	dc or ac (voltage only)	Gravity or spring	Air friction	These instruments have very low power consumption and can be made to cover a large range of voltage. Usually, range is above 500 volts.
4.	Induction	ac measurement (current, voltage, Power and energy) only.	Spring	Eddy current	Ammeters and voltmeters of this type are expensive and not of high degree of accuracy. These instruments are mainly used for measurement of power and energy in ac circuits.
5.	Thermal (i) Hot wire	dc or ac measurement (current, voltage and power)	Spring	Eddy current	These instrument have same calibration for both ac and dc. These are free from errors due to frequency, wave form and external field when used on ac, therefore, these are particularly used for ac measurement.
	(ii) Thermo-couple	dc or ac measurement (current and voltage)			These are free from errors due to frequency, wave form and external field when used on ac and are used for measurement of current and voltage at power frequencies upto 100 MHz.
6.	Rectifier	dc or ac measurement (current and voltage)	Spring	Eddy current	These instruments are nothing but permanent magnet moving coil instruments used in conjunction with rectifying device for AC measurements (current and voltage) from about 20 Hz to 20 kHz.

EXERCISE

Objective-type Questions

- A spring produces a controlling torque of 16×10^{-6} Nm for a deflection of 120Y. If the width and length become two times their original values and the thickness is halved, the value of controlling torque for the same deflection will be
 - 16×10^{-6} N
 - 8×10^{-6} Nm (c) 2×10^{-6} Nm
 - 32×10^{-6} Nm
- The shunt resistance in an ammeter is usually
 - less than meter resistance
 - equal to meter resistance
 - more than meter resistance
 - of any value
- A voltage of 200 V produces a deflection of 90° in a PMMC spring-controlled instrument. If the same instrument is provided with gravity control, what would be the deflection?

- (a) 45°
 - (b) 65°
 - (c) 90°
 - (d) cannot be determined by the given data
4. A current-carrying conductor is shown in Figure (a). If it is brought in a magnetic field shown in Figure (b)
- (a) it will experience a force from left to right.
 - (b) it will experience a force from right to left.
 - (c) it will experience a force from top to bottom.
 - (d) it will experience no force.

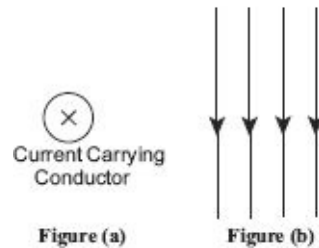

5. The high torque to weight ratio in an analog indicating instrument indicates
- (a) high friction loss
 - (b) nothing as regards friction loss
 - (c) low friction loss
 - (d) none of the above
6. Swamping resistance is connected
- (a) in series with the shunt to reduce temperature error in shunted ammeter
 - (b) in series with the ammeters to reduce errors on account of friction
 - (c) in series with meter and have a high resistance temperature coefficient in order to reduce temperature errors in ammeters.
 - (d) in series with the meter and have a negligible resistance co-efficient in order to reduce temperature errors in shunted ammeters
7. Moving-iron instruments when measuring voltages or currents
- (a) indicate the same values of the measurement for both ascending and descending values
 - (b) indicate higher value of measurand for ascending values
 - (c) indicate higher value of measurand for descending values
 - (d) none of the above
8. A moving-iron type of instrument can be used as
- (a) standard instruments for calibration of other instruments
 - (b) transfer-type instruments
 - (c) indicator-type instruments as on panels
 - (d) all of the above
9. In spring-controlled moving iron instruments, the scale is
- (a) uniform
 - (b) cramped at the lower end and expanded at the upper end
 - (c) expanded at the lower end and cramped at the upper end
 - (d) cramped both at the lower and the upper ends

10. Thermocouple instruments can be used for a frequency range
- up to 500 Hz
 - up to 5 MHz
 - up to 100 Hz
 - up to 1 MHz
11. The reason why eddy-current damping cannot be used in a moving-iron instrument, is
- they have a strong operating magnetic field
 - they are not normally used in vertical position
 - they need a large damping force which can only be provided by air friction
 - they have a very weak operating magnetic field and introduction of a permanent magnet required for eddy current damping would distort the operating magnetic field
12. An electro-dynamometer type of instrument finds its major use as
- standard instrument only
 - both as standard and transfer instrument
 - transfer instrument only
 - indicator-type instrument
13. The frequency range of moving-iron instruments is
- audio-frequency band 20 Hz to 20 kHz
 - very low-frequency band 10 Hz to 30 kHz
 - low-frequency band 30 Hz to 300 kHz
 - power frequencies 0 to 125 Hz.
14. A voltage of 200 V at 5 Hz is applied to an electro-dynamometer type of instrument which is spring controlled. The indication on the instrument is
- 200 V
 - 0 V
 - the instrument follows the variations in voltage and does not give a steady response
 - none of the above
15. Spring-controlled moving-iron instruments exhibit a square law response resulting in a non-linear scale. The shape of the scale can be made almost linear by
- keeping rate of change of inductance, L , with deflection, θ , as constant
 - keeping $\frac{1}{\theta} \cdot \frac{dL}{d\theta}$ as constant
 - keeping $\theta \cdot \frac{dL}{d\theta}$ as constant
 - keeping $\frac{1}{k\theta}$ as constant, where k is the spring constant
16. Electrostatic-type instruments are primarily used as
- ammeters
 - voltmeters
 - wattmeters
 - ohmmeters
17. The sensitivity of a PMMC instrument is $10 \text{ k}\Omega/\text{V}$. If this instrument is used in a rectifier-type voltmeter with half wave rectification. What would be the sensitivity?
- $10 \text{ k}\Omega/\text{V}$
 - $4.5 \text{ k}\Omega/\text{V}$

- (c) $9 \text{ k}\Omega/\text{V}$
 (d) $22.2 \text{ k}\Omega/\text{V}$
18. The heater wire of thermocouple instrument is made very thin in order
- to have a high value of resistance
 - to reduce skin effects at high frequencies
 - to reduce the weight of the instrument
 - to decrease the over-ranging capacity of the instrument
19. Which instrument has the highest frequency range with accuracy within reasonable limits?
- PMMC
 - Moving iron
 - Electrodynamometer
 - Rectifier
20. Which meter has the highest accuracy in the prescribed limit of frequency range?
- PMMC
 - Moving iron
 - Electrodynamometer
 - Rectifier

Answers						
1. (c)	2. (a)	3. (c)	4. (d)	5. (c)	6. (d)	7. (c)
8. (c)	9. (b)	10. (d)	11. (d)	12. (b)	13. (d)	14. (c)
15. (c)	16. (b)	17. (b)	18. (b)	19. (d)	20. (a)	

Short-answer Questions

- Describe the various operating forces needed for proper operation of an analog indicating instrument.
- Sketch the curves showing deflection versus time for analog indicating instruments for underdamping, critical damping and overdamping.
- What are the difference between recording and integrating instruments? Give suitable examples in each case.
- Derive the equation for deflection of a PMMC instrument if the instrument is spring controlled.
- How can the current range of a PMMC instrument be extended with the help of shunts?
- Derive the equation for deflection of a spring-controlled moving-coil instrument.
- Describe the working principle of a rectifier-type instrument. What is the sensitivity of such an instrument?
- What are the advantages and disadvantages of a PMMC instrument?
- Describe the working principle and constructional details of an attraction-type moving iron instrument.
- Derive the expression for deflection for a rotary-type electrostatic instrument using spring control.
- What is swamping resistance? For what purpose is swamping resistance used?
- How many ways can the damping be provided in an indicating instrument?

Long-answer Questions

- How many operating forces are necessary for successful operation of an indicating instrument? Explain the methods of providing these forces.
 - A moving-coil instrument has the following data: number of turns = 100, width of coil = 20 mm, depth of coil = 30 mm, flux density in the gap = 0.1 Wb/m^2 . Calculate the deflecting torque when carrying a current of 10 mA. Also calculate the deflection if the control spring constant is $2 \times 10^{-6} \text{ N-m/degree}$.

[Ans. $60 \times 10^{-6} \text{ Nm}$, 30°]

2. (a) What are the advantages and disadvantages of moving-coil instruments?
- (b) A moving-coil voltmeter has a resistance of 200Ω and the full scale deflection is reached when a potential difference of 100 mV is applied across the terminals. The moving coil has effective dimensions of $30 \text{ mm} \times 25 \text{ mm}$ and is wound with 100 turns. The flux density in the gap is 0.2 Wb/m^2 . Determine the control constant of the spring if the final deflection is 100° and a suitable diameter of copper wire for the coil winding if 20% of the total instrument resistance is due to the coil winding. Resistivity of copper is $1.7 \times 10^{-8} \Omega\text{m}$.
- [Ans. $0.075 \times 10^{-6} \text{ Nm/degree}$; 0.077 mm]
3. (a) Derive the expression for the deflection of a spring controlled permanent magnet moving coil instrument. Why not this instrument able to measure the ac quantity?
- (b) The coil of a moving coil voltmeter is $40 \text{ mm} \times 30 \text{ mm}$ wide and has 100 turns wound on it. The control spring exerts a torque of $0.25 \times 10^{-3} \text{ Nm}$ when the deflection is 50 divisions on the scale. If the flux density of the magnetic field in the air-gap is 1 Wb/m^2 , find the resistance that must be put in series with the coil to give 1 volt per division. Resistance of the voltmeter is 10000Ω .
- [Ans. 14000Ω]
4. (a) A moving-coil instrument has at normal temperature a resistance of 10Ω and a current of 45 mA gives full scale deflection. If its resistance rises to 10.2Ω due to temperature change, calculate the reading when a current of 2000 A is measured by means of a 0.225×10^{-3} shunt of constant resistance. What is the percentage error?
- [Ans. 44.1 mA , -1.96%]
- (b) The inductance of a certain moving-iron ammeter is $(8 + 4\theta - \frac{1}{2}\theta^2)$ pH, where θ is the deflection in radian from the zero position. The control spring torque is $12 \times 10^{-6} \text{ Nm/rad}$. Calculate the scale position in radian for current of 5 A .
- [2.04 rad]
5. (a) Discuss the constructional details of a thermocouple-type instrument used at very high frequencies. Write their advantages and disadvantages.
- (b) The control spring of a moving-iron ammeter exerts a torque of $0.5 \times 10^{-7} \text{ Nm/degree}$ when the deflection is 52° . The inductance of the coil varies with pointer deflection according to
- | | | | | |
|---------------------|-----|-----|-----|-----|
| deflection (degree) | 20 | 40 | 60 | 80 |
| inductance (mH) | 659 | 702 | 752 | 792 |
- Determine the current passing through the meter.
- [0.63 A]
6. (a) Describe the constructional details of an attraction-type moving iron instrument with the help of a neat diagram. Derive the equation for deflection if spring control is used and comment upon the shape of scale.
- (b) Derive a general equation for deflection for a spring-controlled repulsion-type moving-iron instrument. Comment upon the shape of the scale. Explain the methods adopted to linearise the scale.

3

Instrument Transformers

3.1

INTRODUCTION

Instrument transformers are used in connection with measurement of voltage, current, energy and power in ac circuits. There are principally two reasons for use of instrument transformers in measurement: first, to extend (multiply) the range of the measuring instrument and second, to isolate the measuring instrument from a high-voltage line.

In power systems, levels of currents and voltages handled are very high, and, therefore, direct measurements with conventional instruments is not possible without compromising operator safety, and size and cost of instrument. In such a case, instrument transformers can be effectively used to step down the voltage and current within range of the existing measuring instruments of moderate size. Instrument transformers are either (a) current transformer or CT, or (b) voltage or potential transformers or PT. The former is used to extend current ranges of instruments and the latter for increasing the voltage ranges.

Instrument transformers have their primary winding connected to the power line and secondary windings to the measuring instrument. In this way, the measuring instruments are isolated from the high power lines. In most applications, it is necessary to measure the current and voltage of large alternators, motors, transformers, buses and other power transmission equipments for metering as well as for relaying purposes. Voltages in such cases may range from 11,000 to even 330,000 V. It would be out of question to bring down these high-voltage lines directly to the metering board. This will require huge insulation and pose great danger for operating personnel otherwise. In such a case, instrument transformers can greatly solve this problem by stepping down the high voltage to safe levels for measurement.

3.2

ADVANTAGES OF INSTRUMENT TRANSFORMERS

Shunt and multipliers used for extension of instrument ranges are suitable for dc circuits and to some extent, for low power, low accuracy ac circuits. Instrument transformers have certain distinguishing characteristics as compared to shunts and multipliers, as listed below.

1. Using shunts for extension of range on ammeters in ac circuits will require careful designing of the reactance and resistance proportions for the shunt and the meter. Any deviation from the designed time constants of the shunt and the meter may lead to errors in measurement. This problem is not present with CT being used with ammeter.

2. Shunts cannot be used for circuits involving large current; otherwise the power loss in the shunt itself will become prohibitably high.
3. Multipliers, once again, due to inherent leakage current, can introduce errors in measurement, and can also result in unnecessary heating due to power loss.
4. Measuring circuits involving shunts or multipliers, being not electrically isolated from the power circuit, are not only safe for the operator, but also insulation requirements are exceedingly high in high-voltage measurement applications.
5. High voltages can be stepped down by the PT to a moderate level as can be measured by standard instruments without posing much danger for the operator and also not requiring too much insulation for the measuring instrument.
6. Single range moderate size instruments can be used to cover a wide range of measurement, when used with a suitable multi-range CT or PT.
7. Clamp-on type or split-core type CT's can be very effectively used to measure current without the need for breaking the main circuit for inserting the CT primary winding.
8. Instrument transformers can help in reducing overall cost, since various instruments, including metering, relaying, diagnostic, and indicating instruments can all be connected to the same instrument transformer.

3.3

CURRENT TRANSFORMERS (CT)

The primary winding of a current transformer is connected in series with the line carrying the main current. The secondary winding of the CT, where the current is many times stepped down, is directly connected across an ammeter, for measurement of current; or across the current coil of a wattmeter, for measurement of power; or across the current coil of a watt-hour meter for measurement of energy; or across a relay coil. The primary winding of a CT has only few turns, such that there is no appreciable voltage drop across it, and the main circuit is not disturbed. The current flowing through the primary coil of a CT, i.e., the main circuit current is primarily determined by the load connected to the main circuit and not by the load (burden) connected to the CT secondary. Uses of CT for such applications are schematically shown in [Figure 3.1](#).

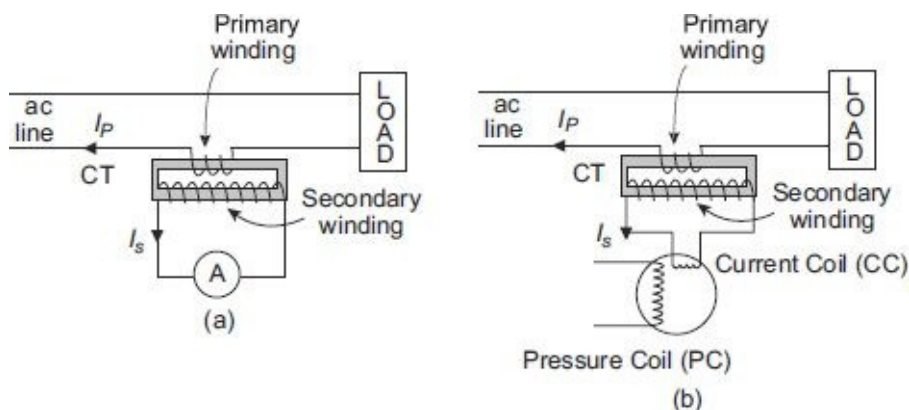

Figure 3.1 CT for (a) current, and (b) power measurement

One of the terminals of the CT is normally earthed to prevent any accidental damage to the operating personnel in the event of any incumbent insulation breakdown.

When a typical name plate rating of a CT shows 500/1 A 5 VA 5P20 it indicates that the CT rated primary and secondary currents are 500 A and 1 A respectively, its rated secondary burden is 5 VA, it is designed to have 5% accuracy and it can carry up to 20 times higher current than its rated value while connected in line to detect fault conditions, etc.

3.4

THEORY OF CURRENT TRANSFORMERS

Figure 3.2 represents the equivalent circuit of a CT and Figure 3.3 plots the phasor diagram under operating condition of the CT.

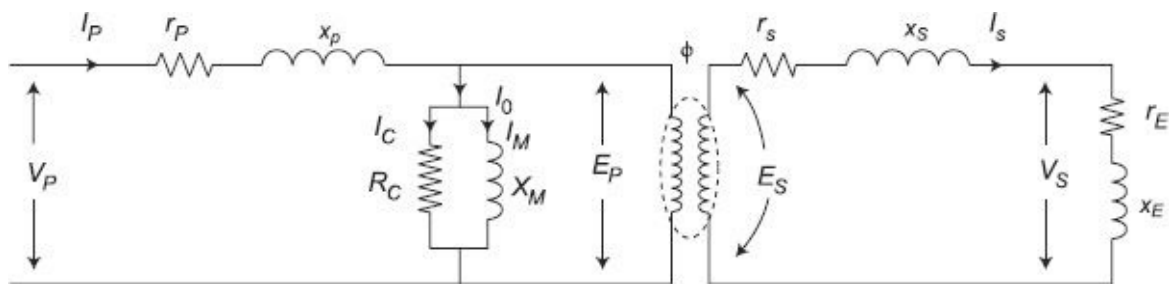

Figure 3.2 Equivalent circuit of a CT

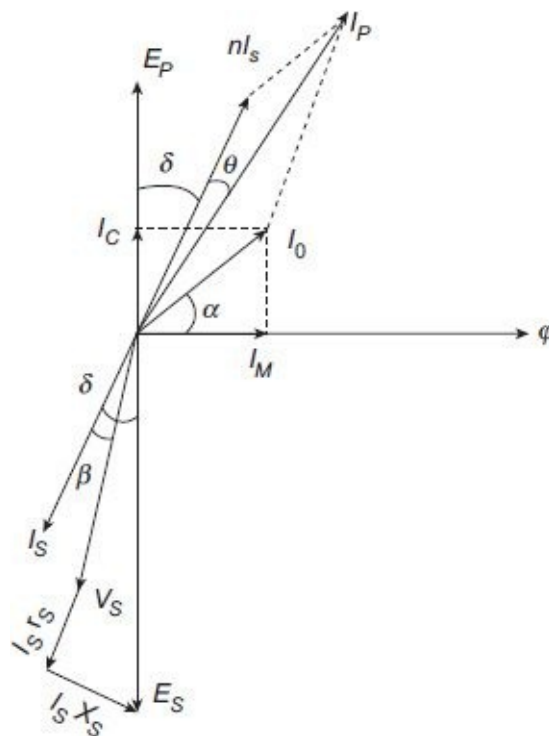

Figure 3.3 Phasor diagram of a CT

V_p = primary supply voltage

E_p = primary winding induced voltage

V_s = secondary terminal voltage

E_S = secondary winding induced voltage

I_P = primary current

I_S = secondary current

I_0 = no-load current

I_C = core loss component of current

I_M = magnetising component of current

r_P = resistance of primary winding

x_P = reactance of primary winding

r_S = resistance of secondary winding

x_S = reactance of secondary winding

R_C = imaginary resistance representing core losses

X_M = magnetising reactance

r_e = resistance of external load (burden) including resistance of meters, current coils, etc.

x_E = reactance of external load (burden) including reactance of meters, current coils, etc.

N_P = primary winding number of turns

N_S = secondary winding number of turns

n = turns ratio = N_S/N_P

ϕ = working flux of the CT

θ = the "phase angle" of the CT

δ = phase angle between secondary winding induced voltage and secondary winding current (i.e. phase angle of total burden, including secondary winding)

β = phase angle of secondary load (burden) circuit only

α = phase angle between no-load current I_0 and flux ϕ

The flux ϕ is plot along the positive x-axis. Magnetising component of current I_M is in phase with the flux. The core loss component of current I_C , leads by I_M 90° . Summation of I_C and I_M produces the no-load current I_0 , which is α angle ahead of flux ϕ .

The primary winding induced voltage E_P is in the same phase with the resistive core loss component of the current I_C . As per transformer principles, the secondary winding induced voltage E_S will be 180° out of phase with the primary winding induced voltage E_P . The secondary current I_S lags the secondary induced voltage E_S by angle δ .

The secondary output terminal voltage V_S is obtained by vectorically subtracting the secondary winding resistive and reactive voltage drops $I_S r_S$ and $I_S x_S$ respectively from the secondary induced voltage E_S . The phase angle difference between secondary current I_S and secondary terminal voltage V_S is β , which is the phase angle of the load (burden).

The secondary current I_S , when reflected back to primary, can be represented by the 180° shifted phasor indicated by nI_S , where n is the turns ratio. The primary winding current I_P is the phasor summation of this reflected secondary current (load component) nI_S and the no-load current I_0 .

The phase angle difference θ between the primary current I_P and the reflected secondary current nI_S is called phase angle of the CT.

3.4.1 Current Transformation Ratio of CT

Redrawing expanded view of the phasor diagram of [Figure 3.3](#), we obtain the phasor diagram of [Figure 3.4](#).

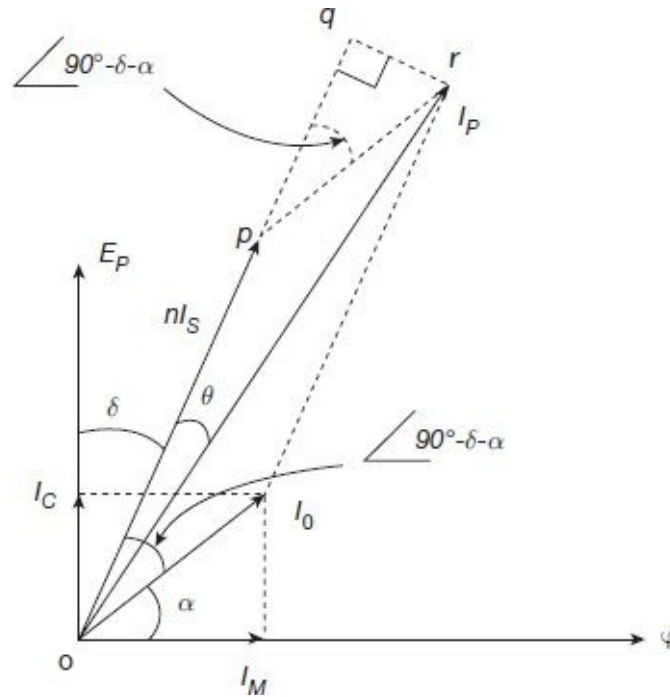

Figure 3.4 Expanded view of a section of [Figure 3.3](#)

From the right-angle triangle pqr , we get

$$pr = I_0$$

$$pq = I_0 \cdot \cos(90^\circ - \delta - \alpha) = I_0 \cdot \sin(\delta + \alpha)$$

$$qr = I_0 \cdot \sin(90^\circ - \delta - \alpha) = I_0 \cdot \cos(\delta + \alpha)$$

Now, $(or)^2 = (op + pq)^2 + (qr)^2$

Or, $(I_P)^2 = (nI_S + I_0 \cdot \sin(\delta + \alpha))^2 + (I_0 \cdot \cos(\delta + \alpha))^2$

$$\begin{aligned}
&= n^2 I_S^2 + I_0^2 \cdot \sin^2 (\delta + \alpha) + 2nI_S I_0 \cdot \sin(\delta + \alpha) + I_0^2 \cdot \cos^2 (\delta + \alpha) \\
&= n^2 I_S^2 + 2nI_S I_0 \cdot \sin(\delta + \alpha) + I_0^2 (\sin^2 (\delta + \alpha) + \cos^2 (\delta + \alpha)) \\
&= n^2 I_S^2 + 2nI_S I_0 \cdot \sin(\delta + \alpha) + I_0^2
\end{aligned}$$

$$\therefore I_p = \sqrt{n^2 I_S^2 + 2nI_S I_0 \cdot \sin(\delta + \alpha) + I_0^2} \quad (3.1)$$

In a well-designed CT, the no-load current I_0 is much less as compared to the primary current I_p or even the reflected secondary current (which is nominally equal to the primary current) nI_S .

i.e., $I_0 \ll nI_S$

Equation (3.1) can thus now be approximated as

$$I_p = \sqrt{n^2 I_S^2 + 2nI_S I_0 \cdot \sin(\delta + \alpha) + (I_0 \cdot \sin(\delta + \alpha))^2}$$

Hence, $I_p = nI_S + I_0 \cdot \sin(\delta + \alpha)$

CT transformation ratio can now be expressed as

$$R = \frac{I_p}{I_S} = \frac{nI_S + I_0 \cdot \sin(\delta + \alpha)}{I_S} = n + \frac{I_0}{I_S} \sin(\delta + \alpha)$$

Though approximate, Eq. (3.2) is sufficiently accurate for practical estimation of CT transformation ratio. The above equation, however, is true for only when the power factor of the burden is lagging, which is mostly true in all practical inductive meter coils being used as burden.

Equation (3.2) can be further expanded as

$$R = n + \frac{I_0}{I_S} \sin(\delta + \alpha) = n + \frac{I_0}{I_S} (\sin \delta \cos \alpha + \cos \delta \sin \alpha)$$

or, transformation ratio $R \approx n + \frac{I_M \sin \delta + I_C \cos \delta}{I_S}$

[since, $I_M = I_0 \cos \alpha$ and $I_C = I_0 \sin \alpha$]

3.4.2 Phase Angle of CT

As can be seen from the phasor diagram in [Figure 3.3](#), the secondary current of a CT is almost 180° out of phase from the primary current. If the angle was exactly 180° then there would have been no phase angle error introduced in the CT when it is to be used along with wattmeter for power measurements. In reality, however, due to presence of the parallel circuit branches, namely, the magnetising and the core loss branches, the phase angle difference is usually less than 180° . This causes some error in phase to be introduced while CT operation in practice.

The angle by which the secondary current phasor, when reversed, i.e., the reflected secondary current phasor nI_S , differs in phase from the primary current I_p , is called the **phase angle of the CT**. This angle is taken as positive when the reversed secondary

current **leads** the primary current, in other cases when the reversed secondary current lags the primary current, the CT phase angle is taken as negative.

From the phasor diagram in [Figure 3.4](#),

$$\begin{aligned}\tan \theta &= \frac{qr}{oq} = \frac{qr}{po + qp} = \frac{I_0 \cdot \sin[90^\circ - (\delta + \alpha)]}{nI_S + I_0 \cdot \cos[90^\circ - (\delta + \alpha)]} \\ &= \frac{I_0 \cdot \cos(\delta + \alpha)}{nI_S + I_0 \cdot \sin(\delta + \alpha)}\end{aligned}$$

For very small angles, $\theta \approx \frac{I_0 \cdot \cos(\delta + \alpha)}{nI_S + I_0 \cdot \sin(\delta + \alpha)}$

This expression can still be simplified with the assumption $I_0 \ll nI_S$.

$$\theta \approx \frac{I_0 \cos(\delta + \alpha)}{nI_S} \text{ rad}$$

$$\text{Or, } \theta \approx \frac{I_0(\cos \delta \cos \alpha - \sin \delta \sin \alpha)}{nI_S} \approx \frac{I_M \cos \delta - I_C \sin \delta}{nI_S} \text{ rad}$$

$$\text{Or, phase angle of CT } \theta \approx \frac{180}{\pi} \left(\frac{I_M \cos \delta - I_C \sin \delta}{nI_S} \right) \text{ degree}$$

3.5

ERRORS INTRODUCED BY CURRENT TRANSFORMERS

When used for current measurement, the only essential requirement of a CT is that its secondary current should be a pre-defined fraction of the primary current to be measured. This ratio should remain constant over the entire range of measurement, such that no errors are introduced in the measurement. However, from Eq. (3.3), it is clear that the transformation ratio R of the CT differs from the turns ratio n . This difference is not constant, but depends on the magnitude of magnetising and loss components of no-load current, and also on the secondary winding load current and its phase angle. The secondary winding current thus is never a constant fraction of the primary winding current under all conditions of load and of frequency. This introduces considerable amount of error in current measurement.

While power measurements, it is required that the secondary current of CT is displaced exactly by 180° from the primary current. As seen from Eq. (3.6), this condition is not fulfilled, but the CT has a phase angle error θ . This will introduce appreciable error during power measurements.

3.5.1 Ratio Error

Ratio error is defined as

$$\begin{aligned}\text{Percentage ratio error} &= \frac{\text{Nominal ratio} - \text{Actual ratio}}{\text{Actual ratio}} \times 100\% \\ &= \frac{Kn - R}{R} \times 100\%\end{aligned}$$

$$\text{where, Nominal ratio} = \frac{\text{Rated primary winding current}}{\text{Rated secondary winding current}} = Kn \approx n$$

In practice, the CT burden is largely resistive with a small value of inductance, thus the secondary phase angle δ is positive and generally small. The nominal ratio Kn , is sometimes loosely taken equal to the turns ratio n . This assumption, as will be described in later sections, is true in the case when turns compensation is not used in CT.

Thus, $\sin \delta \approx 0$ and $\cos \delta \approx 1$. Therefore, Eq. (3.3) can be approximated as

$$R \approx n + \frac{I_M \sin \delta + I_C \cos \delta}{I_S} \approx n + \frac{I_C}{I_S}$$

Accordingly, percentage ratio error can be approximated as

$$\text{Percentage ratio error} = \frac{Kn - \left(n + \frac{I_C}{I_S}\right)}{\left(n + \frac{I_C}{I_S}\right)} \times 100\%$$

3.5.2 Phase-Angle Error

Error in phase angle is given following Eq. (3.6) as

$$\theta \approx \frac{180}{\pi} \left(\frac{I_M \cos \delta - I_C \sin \delta}{nI_S} \right)$$

In practice, the CT burden is largely resistive with a small value of inductance, thus the secondary phase angle δ is positive and generally small.

Thus, $\sin \delta \approx 0$ and $\cos \delta \approx 1$. Therefore, Eq. (3.10) can be approximated as

$$\theta \approx \frac{180}{\pi} \times \frac{I_M}{nI_S} \text{ degree}$$

3.5.3 Causes of Errors in CT

In an ideal CT, the actual transformation ratio should have been exactly equal to the turns ratio and the phase angle should have been zero. However, due to inherent physical limitations inherent to the electric and magnetic circuits of the CT, practical performance deviates from these ideal behaviors and errors are introduced in measurement. The reasons for these errors are given here.

1. Primary winding always needs some magnetising MMF to produce flux and, therefore, the CT draws the magnetising current I_M .
2. CT no-load current must have a component I_C that has to supply the core losses, i.e., the eddy current loss and the hysteresis loss.
3. Once the CT core becomes saturated, the flux density in the core no longer remains a linear function of the magnetising force, this may introduce further errors.
4. Primary and secondary flux linkages differ due to unavoidable flux leakages.

3.5.4 Reducing Errors in CT

Errors are produced in the ratio and phase angle of a CT owing to the presence of the no-load component of the primary current. Improvement of accuracy, then, depends upon

minimising this component or nullifying in some way its effects in introducing errors. The most obvious idea would be to attempt to keep the magnetising current component as small as possible. This can be achieved by a combination of the following schemes:

1. *Low Flux Density*

The magnetising component of current may be restricted by using low values of flux density. This may be achieved by using large cross-section for core. For this reason, CTs are normally designed with much lower flux densities as compared to a normal power transformer.

2. *High Permeability Core Material*

The magnetising component of current may be made small by the use of high permeability core material. Some special core materials, such as Permalloy, are even better than the highest grade silicon steel with respect to permeability, particularly at lower flux densities. Hipernik (50% Fe + 50% Ni) has high permeability at low flux densities along with reasonably high saturation density value. It is used frequently as core material for manufacturing CTs.

3. *Modification of Turns Ratio*

The accuracy of current transformers may be improved, at least in terms of transformation ratio, by suitably modifying the actual number of turns. Instead of using the number of turns in exact accordance with the desired nominal ratio, a change in few numbers of turns may be made in the secondary winding. Primary number of turns itself being so less, any change in number of turns in the primary may result in wide variation of the turns ratio. For normal operating conditions, the usual secondary current is found to be less than the nominal value due to the no-load current. Correction in such cases, thus, may be made by a small reduction in the secondary number of turns. This correction can, however, be exact only for particular value of current and burden impedance. CTs in such cases are normally marked as 'compensated' for that particular operating condition.

4. *Use of Shunts*

If the secondary current is found to be too high, it may be reduced by a shunt placed across primary or secondary. This method can make an exact correction, once again, only for a particular value and type of burden. Use of shunts can also help in reducing the phase-angle error.

5. *Wound-Core Construction*

An improvement in the magnetisation characteristics of the CT core may be achieved by the use of wound-core construction. This type of construction for the core has been in use for some time in distribution transformers. By special treatment of the silicon steel to be used as core material, and by using it to carry flux always in the direction of grain orientation (rolling the sheet steel in proper way), magnetic properties of the core can be

largely improved. This improvement may be utilised in CTs to reduce the ratio and phase angle errors.

3.6

OPERATIONAL CHARACTERISTICS OF CURRENT TRANSFORMERS

Characteristics of current transformers under different operating conditions may be estimated from the phasor diagram as shown in [Figure 3.3](#).

3.6.1 Effect of Change in Burden on Secondary Circuit

Burden connected with the CT secondary may include ammeters, wattmeter current coils, relay coils, and so forth. All these being connected in series, carry the same current through them. In a current transformer, since the current depends solely on the primary current, an increase in the burden impedance will not change the secondary current, but will demand more voltage in the secondary terminals. This will increase volt-ampere burden of the secondary. With more instruments in the circuit, a higher voltage is required to make the current flow and this, in turn, requires more flux to flow through the core and hence a greater magnetising component of the primary current. This will result in an increase in the ratio and phase angle error of the current transformer. [Figure 3.5](#) summarises the variations of ratio and phase angle errors in a typical current transformer at different values of the secondary burden VA.

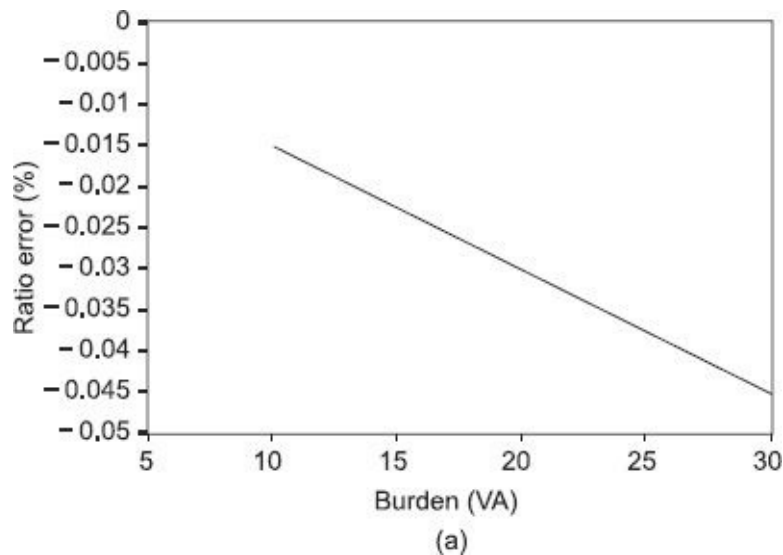

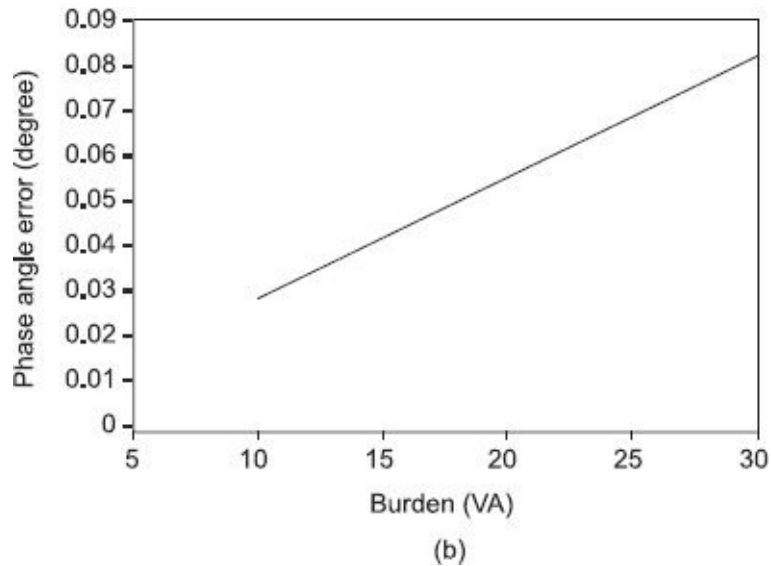

Figure 3.5 Effects of secondary burden variation on (a) CT ratio error, and (b) CT phase-angle error

3.6.2 Effect of Change in Power Factor of Secondary Burden

1. Ratio Error

As can be observed from the phasor diagram of a current transformer in Figure 3.3, for all inductive burdens, the secondary winding current I_S lags behind the secondary induced voltage E_S , so that the phase angle difference δ is positive. Under these conditions, from Eq. (3.2), the actual transformation ratio is always greater than the turns ratio, and thus according to Eq. (3.9), ratio error is always negative for inductive (lagging power factor) burdens.

For highly capacitive burdens, the secondary winding current I_S leads the secondary induced voltage E_S , so that the phase angle difference δ is negative. In such a case, the actual transformation ratio may even become less than the turns ratio and ratio error may thus become positive.

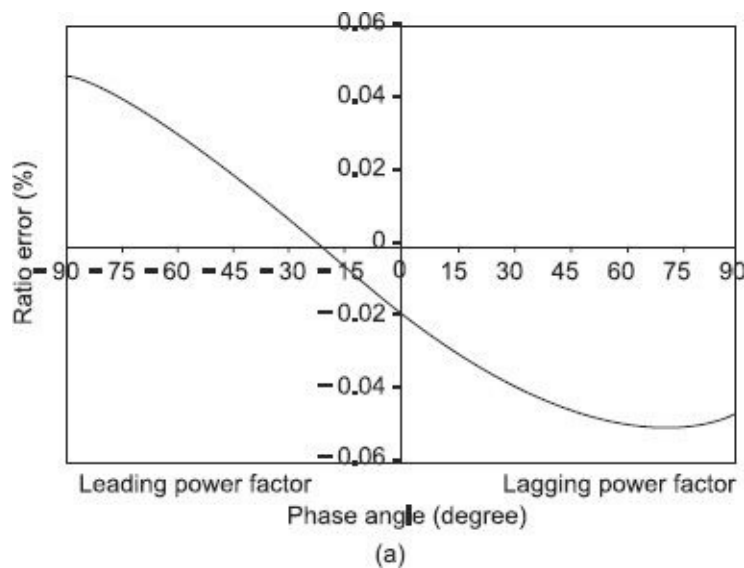

2. Phase-Angle Error

From Eq. (3.5) it is observed that for inductive burdens, the phase angle error remains

positive till a certain low value of power factor is reached at highly inductive burdens when the phase angle error crosses over the axis to turn negative. For capacitive burdens, however, the phase-angle error always remains positive.

Figure 3.6 shows the variations of ratio and phase-angle errors in a typical current transformer at different values of the secondary burden power factor. These variations are described with the assumption of secondary burden VA to remain constant.

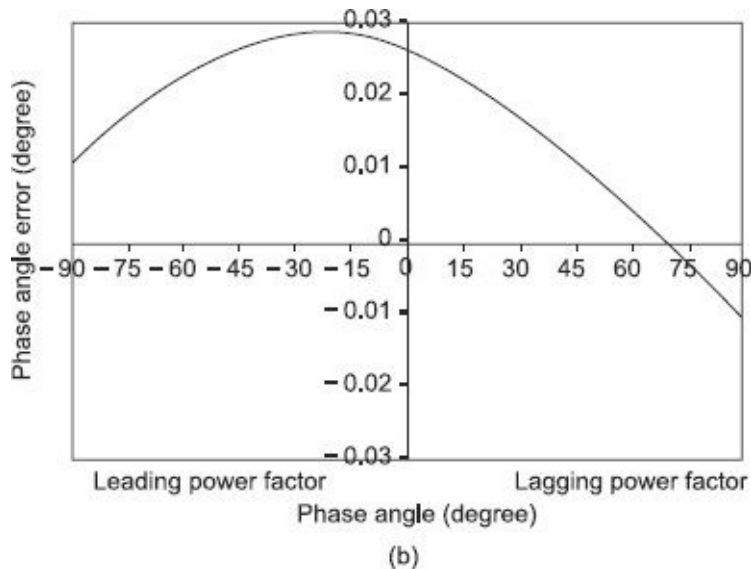
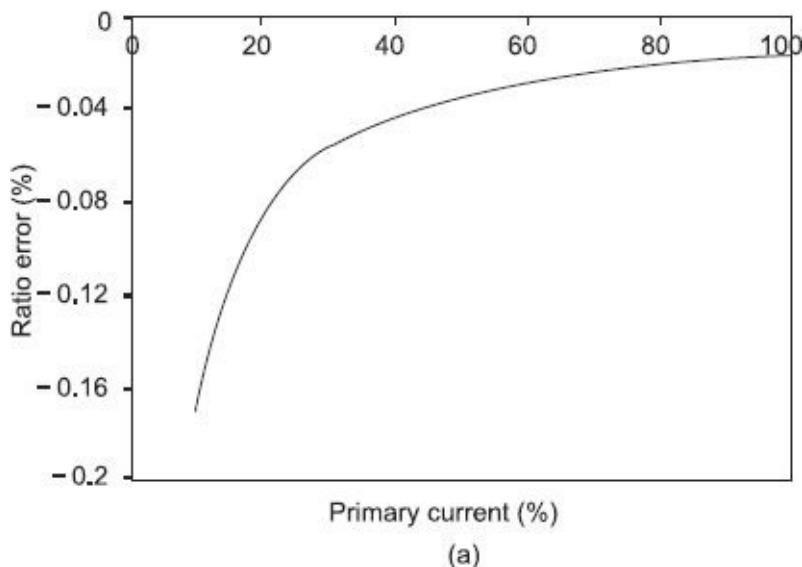

Figure 3.6 Effects of secondary burden power factor variation on (a) CT ratio error, and (b) CT phase-angle error

3.6.3 Effect of Change in Primary Winding Current

As the primary winding current I_p changes, the secondary winding current I_s also changes proportionately. With lower values of I_p (and I_s), the magnetising and loss components of no-load current become comparatively higher, and, therefore, both of ratio and phase angle errors become higher. As the primary current I_p increases, the secondary current I_s also increases, thereby reducing the proportions of magnetising and loss components of currents, which reduces the ratio and phase angle errors. These observations can be verified following Eqs (3.2) and (3.5).

Such variations of CT errors with changing primary (and hence secondary) current under a typical unity power factor burden are shown in Figure 3.7.



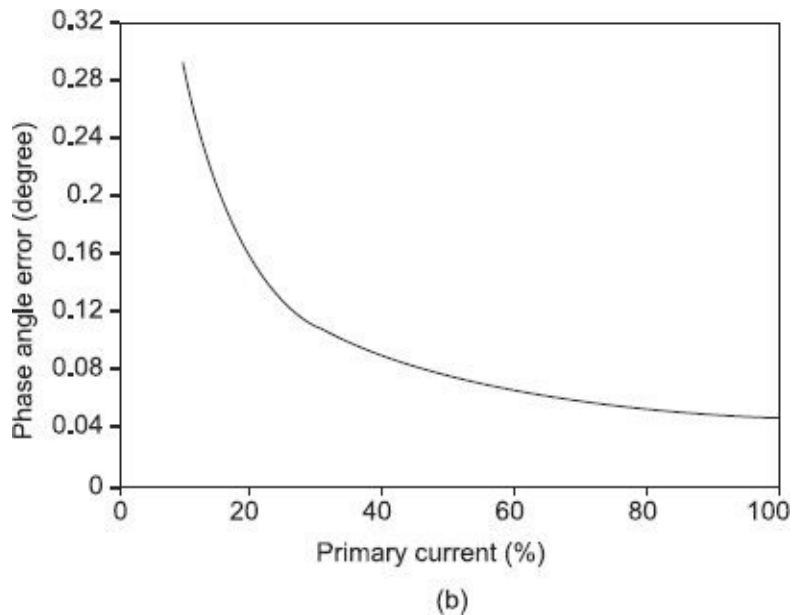

Figure 3.7 Effects of primary current variation on (a) CT ratio error, and (b) CT phase-angle error

3.7

DESIGN AND CONSTRUCTIONAL FEATURES OF CURRENT TRANSFORMERS

3.7.1 Design Features

1. Number of Primary Ampere-Turns (AT)

One of the primary conditions for restricting ratio and phase-angle errors is that the magnetising ampere-turns in the primary shall be only a small proportion of the total primary ampere turns. To satisfy this condition, in most practical cases, the number of primary ampere-turns may be estimated as to be in the range 5000–10000. In the case of CTs having a single bar as their primary winding, the number of primary ampere turns is, of course, determined by the primary current. For most practical purposes, with commercially available magnetic materials at the core of the CT, primary currents not less than 100 A have proved to be necessary for producing satisfactory amount of ampere turns.

2. Core

To satisfy the condition of achieving low magnetising ampere-turns, the core material must have a low reluctance and low iron loss. The flux density in the core also needs to be restricted to low values. Core materials such as Mumetal (an alloy of iron and nickel containing copper) has properties of high permeability, low loss, and low retentivity—all of which are advantageous for being used in CTs. Mumetal, however, has the disadvantage of having low saturation flux densities.

The length of magnetic path in the core should be as small as permissible from the point of view of mechanical construction and with proper insulation requirements in order to reduce the core reluctance. For similar reasons, core joints should be avoided as far as

practicable, or in other case, core joints must be as efficient as possible by careful assembly.

3. Windings

Primary and secondary windings should be placed close together to reduce the leakage reactance; otherwise the ratio error will go up. Thin SWG wires are normally used for secondary winding, whereas copper strips are generally used for primary winding, dimensions of which depend, obviously, upon the primary current.

The windings need to be designed for proper robustness and tight bracing with a view to withstand high mechanical forces without damage. Such mechanical forces may get developed due to sudden short circuits in the system where the CT is connected.

4. Insulation

Lower voltage rating applications allow windings to be insulated with tape and varnish. Higher voltage applications, however, require oil-immersed insulation arrangements for the winding. Still high voltages may require use of solid compound insulation systems.

3.7.2 Constructional Features

1. Indoor Type CTs

For indoor table/panel mounted applications, winding construction can be of two types in a CT: (i) wound type, and (ii) bar type.

In wound-type winding, the primary winding consists of a few turns of heavy conductor to whose projected ends, the primary conductor, cable or bus bar is bolted. The secondary winding, which composes of a large number of turns, is wound over a Bakelite former around a central core. The heavy primary conductor is either wound directly on top of the secondary winding, suitable insulation being first applied over the secondary winding, or the primary is wound entirely separately, insulated with suitable tape and then assembled with the secondary winding on the core. The entire system is housed, normally, within a molded insulation cover. [Figure 3.8\(a\)](#) shows a schematic diagram of the cross section of a wound-type CT. [Figure 3.8 \(b\)](#) shows a photograph of such a wound-type CT.

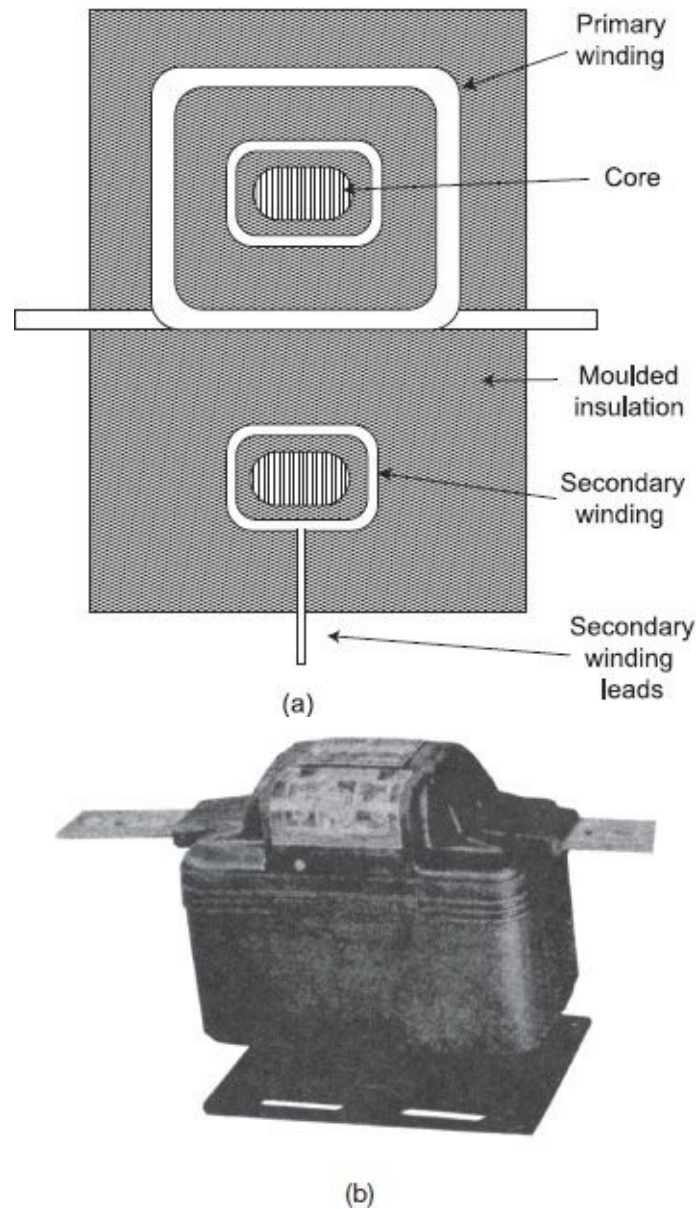

Figure 3.8 (a) Cross section of wound-type CT (b) Butyl-molded wound primary type indoor CT (Courtesy of General Electric Company)

The bar-type CT includes the laminated core and secondary winding but no primary winding as such. The primary consists of the bus-bar or conductor, which is passed through the opening in the insulating sleeve through the secondary winding. The primary winding (bar) here forms an integral part of the CT. Such CTs are sometimes termed as single-turn primary-type CT. The external diameter of the bar type primary must be large enough to keep the voltage gradient in the dielectric at its surface, to an acceptable value such that corona effect can be avoided. [Figure 3.9](#) shows a schematic diagram of the cross-section of a bar-type CT. [Figure 3.10](#) show photograph of such bar-type CTs.

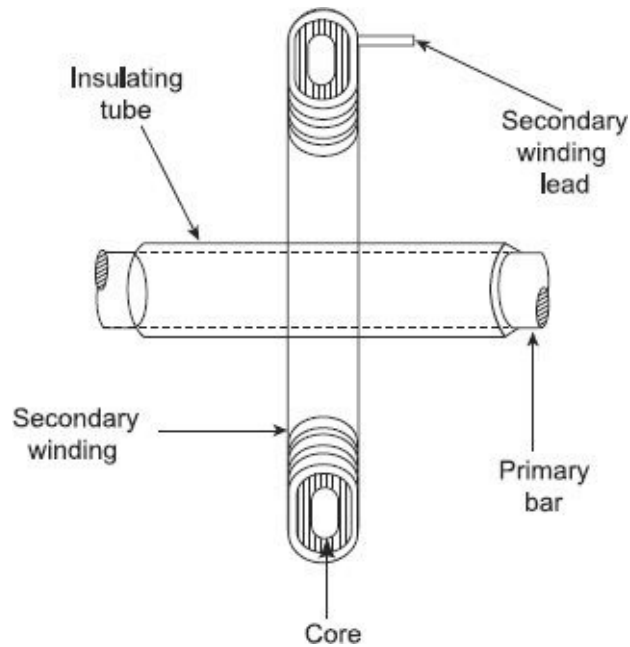

Figure 3.9 Cross section of bar-type CT

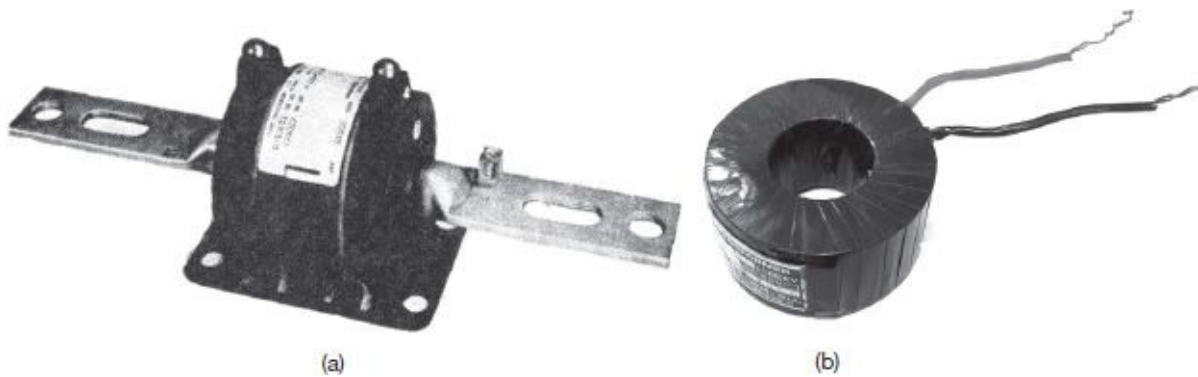

Figure 3.10 (a) Butyl-molded bar primary-type indoor CT for 200–800 A and 600 V range circuit (Courtesy of General Electric Company) (b) Single conductor (bar type) primary CT

2. Clamp-on Type or Portable Type CTs

By the use of a construction with a suitably split and hinged core, upon which the secondary winding is wound, it is possible to measure the current in a heavy-current conductor or bus-bar without breaking the current circuit. The split core of the CT along with the secondary winding is simply clamped around the main conductor, which acts as the primary winding of the CT. When used with range selectable shunts and a calibrated ammeter, clamp on type CTs can be very conveniently used for direct and quick measurement of current. [Figure 3.11](#) shows photograph of such a clamp-on type CT.



Figure 3.11 Multi-range clamp-on type CT (Courtesy of Metravi)

A portable-type CT in which high and largely adjustable current ranges can be obtained by actually winding the primary turns through the core opening is illustrated in [Figure 3.12](#). For example, if one turn of the primary conductor through the opening gives a current ratio of 800/5, then two primary turns through the same opening will give a current ratio of 400/5, and so on.

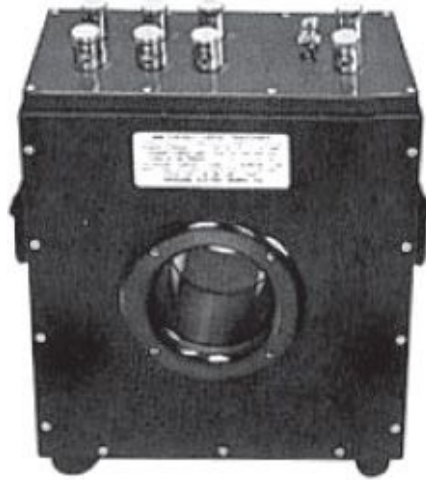
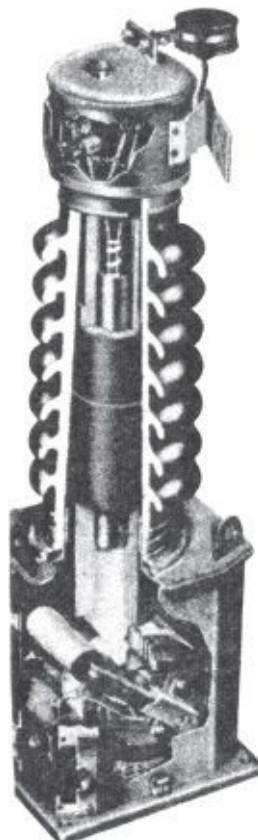

Figure 3.12 Multi-range portable type CT (Courtesy of Yokogawa)

3. Bushing-type CTs

The bushing-type CT is similar in concept to the bar type in the sense that core and secondary winding are mounted around the single primary conductor. It has a circular core that carries the secondary wound over it and forming a unit that may be installed in the high-voltage bushing of a circuit breaker or a power transformer. The ‘primary winding’ in such a case is simply the main conductor in the bushing. [Figure 3.13](#) shows the view of such a bushing-type CT.



3.8

PRECAUTIONS IN USE OF CURRENT TRANSFORMER

3.8.1 Open Circuiting of CT Secondary

Current transformers are always used with its secondary circuit closed through very low resistance loads such as ammeters, wattmeter current coils, or relay coils. In such a case, a current transformer should never have its secondary terminals open circuited while the primary circuit is still energised.

One difference between a normal power transformer and a current transformer is that in a CT, the primary current is independent of the current flowing in the secondary, primary winding being connected in series with the main load, carries the line current. Thus, primary current is in no way controlled by the conditions of the secondary winding circuit of the CT.

Under normal operating conditions, the secondary current produces a so-called 'back-mmf' that almost balances the primary winding ampere turns and restricts the flux in the core. This small mmf is responsible for producing flux in the core and supplies the iron losses. This resultant flux being small, the voltage induced in the secondary winding is also low.

If by any reason whatsoever, the secondary winding gets open circuited, then the secondary reverse mmf vanishes. The demagnetising effect of the secondary mmf is now absent and the core carries the high flux created due to the primary ampere-turns only. This large flux greatly increases flux density in the core and pushes it towards saturation. This large flux, when links with the large number of secondary turns, produces a very high voltage, that could be damaging for the winding insulation as well as dangerous for the operator. The transformer insulation may get damaged under such high voltage stress.

In addition to this, increased hysteresis and eddy current losses at higher flux densities may overheat the transformer core.

Moreover, the high magnetising forces acting on the core while secondary condition tend to magnetise the magnetic material to high values. If the open circuit condition is suddenly removed, the accuracy of the CT may be seriously impaired by the residual magnetism remaining in the core in case the primary circuit is broken or the secondary circuit is re-energised. This residual effect causes the transformer to operate at a different operating point on the magnetisation curve, which affects the permeability and hence the calibration. This may lead to an altogether different values of ratio and phase-angle errors, obtained after such an open circuit, as compared to the corresponding values before it occurred. A transformer so treated, must first be demagnetised and then recalibrated before can be used reliably.

For these reasons, care must be taken to ensure that, even when not in use for measurement purposes, the secondary circuit is closed at any time when the primary circuit is energised. In those idle periods, the secondary circuit could (and should) be

safely short circuited quite safely, since while being used for measurement it is practically short circuited by the ammeter, or wattmeter current coils, impedances of which are merely appreciable.

3.8.2 Permanent Magnetisation of Core

Core material of a CT may undergo permanent magnetisation due to one or more of the following reasons:

1. As discussed earlier, if by any chance the secondary winding is open circuited with the primary winding still energised, then the large flux will tend to magnetise the core to high values. If such a condition is abruptly removed, then there is a good possibility that a large residual magnetism will remain in the core.
2. A switching transient passing through the CT primary may leave behind appreciable amount of residual magnetism in the core.
3. Permanent magnetisation may result from flow of dc current through either of the winding. The dc current may be flown through the winding for checking resistance or checking polarity.
4. Permanent magnetisation may also result from transient short circuit current flowing through the line to which the CT is connected. Such transient currents are found to have dc components along with ac counterparts.

The presence of permanent magnetisation in the core may alter the permeability of the material resulting in loss of calibration and increase in both ratio error and phase angle error. Thus, for reliable operation of the CT, the residual magnetism must be removed and the CT be restored back to its original condition. There are several methods of demagnetising the core as described below:

1. One method is to pass a current through the primary winding equal to the current that was flowing during the period when the CT secondary was open circuited. The CT secondary circuit is left open. The voltage supply to the primary is then gradually reduced to zero. The CT core thus undergoes several cycles of gradually reducing magnetisation till it finishes down to zero.
2. In the second method, the primary winding is supplied from a source so that rated current flows in the primary winding. A variable resistor of value certain hundred ohms is connected across the secondary winding. This simulates almost the CT secondary open circuit condition. The variable resistance is then gradually and uniformly reduced down to zero. In this way, the magnetisation of the CT core gradually reduced down from its initial high value to normal original values.

A current transformer has single-turn primary and a 100-turn secondary winding. The secondary winding of purely resistive burden of 1.5 W draws a current of 6 A. The magnetising ampere-turns is 60 A. Supply frequency is 50 Hz and core cross-sectional area is 800 mm². Calculate the ratio and phase angle of the CT. Also find the flux density in

Example 3.1

the core. Neglect flux leakage, iron losses and copper losses.

Solution Neglecting copper losses and flux leakage implies that secondary winding resistance and reactance are not be considered. The burden of 1.5Ω thus can be assumed to be the burden of the entire secondary circuit.

Secondary induced voltage

$$E_S = \text{Secondary current} \times \text{Secondary burden} = 6 \times 1.5 = 9 \text{ V}$$

As the secondary burden is purely resistive, the secondary current is in phase with the secondary induced voltage, i.e., the phase angle difference between E_S and I_S , $\delta = 0$, and power factor is unity.

Given that iron losses, and hence the loss component of current can be neglected, i.e., $I_C = 0$.

No-load current in this case is thus simply equal to the magnetising component of current, i.e., $I_0 = I_M$

Now, magnetising component of no-load current is given by

$$I_M = \frac{\text{Magnetising mmf}}{\text{Primary winding turns}} = \frac{60}{1} = 60 \text{ A}$$

Secondary winding current $I_S = 6 \text{ A}$

Turns ratio = $n = 100/1 = 100$

Reflected secondary winding current = $nI_S = 100 \times 6 = 600 \text{ A}$

Referring to the phasor diagram shown in the figure, the primary current can be calculated as

$$I_P = \sqrt{(nI_S)^2 + (I_M)^2} = \sqrt{600^2 + 60^2} = 603 \text{ A}$$

\therefore actual transformation ratio

$$R = \frac{I_P}{I_S} = \frac{603}{6} = 100.5$$

$$\text{Phase angle} = \theta = \tan^{-1} \left(\frac{I_M}{nI_S} \right) = \tan^{-1} \frac{60}{600} = 5.7^\circ$$

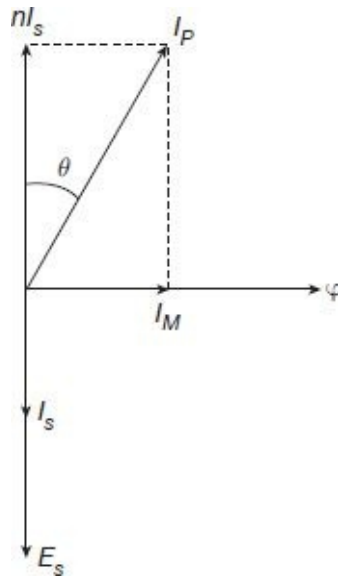

From the relation $E_S = 4.44f\phi_m N_S$, the maximum flux ϕ_M in the core can be calculated as

$$\phi_m = \frac{E_S}{4.44fN_S} = \frac{9}{4.44 \times 50 \times 100} = 0.41 \times 10^{-3} \text{ Wb}$$

Given, area of core = $800 \text{ mm}^2 = 800 \times 10^{-6} \text{ m}^2$

$$\therefore \text{maximum flux density } B_m = \frac{0.41 \times 10^{-3}}{800 \times 10^{-6}} = 0.51 \text{ Wb/m}^2$$

Example 3.2

A ring core type CT has a ratio of 2000/10. When operating at rated primary current with a secondary burden of noninductive resistance value of 2Ω , takes a no-load current of 2 A at power factor of 0.3. Calculate (i) the phase angle difference between primary and secondary currents, and (ii) the ratio error at full load.

Solution Phasor diagram for the corresponding situation with purely resistive burden is shown in the figure.

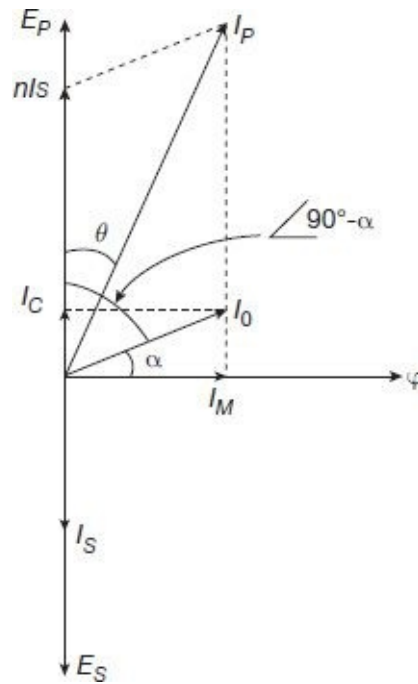

The burden being purely resistive, the secondary current I_S and secondary induced voltage E_S will be in the same phase as shown in the figure. Therefore, secondary winding power factor will be unity and the phase angle difference between I_S and E_S , $\delta = 0$.

Give, no-load current $I_0 = 2$ A, at power factor of 0.3.

$$\therefore \cos(90^\circ - \alpha) = 0.3 \text{ or } \alpha = 17.46^\circ$$

$$\text{Nominal ratio } K_n = \frac{2000}{10} = 200$$

Without any turns compensation, nominal ratio equals the turns ratio, thus $n = K_n$

Under full load rated condition, primary current = 2000 A and secondary current = 10 A.

\therefore transformation ratio

$$R = n + \frac{I_0}{I_S} \sin(\delta + \alpha) = 200 + \frac{2}{10} \sin(0^\circ + 17.46^\circ) = 200.06$$

$$\therefore \text{ratio error} = \frac{\text{Nominal Ratio} - \text{Actual Ratio}}{\text{Actual Ratio}} \times 100\% = \frac{K_n - R}{R} \times 100\%$$

A 1500/5 A, 50 Hz single-turn primary type CT has a secondary burden comprising of a pure resistance of 1.5 Ω . Calculate flux in the core, ratio error and phase-angle error at full load. Neglect leakage reactance and assume the iron loss in the core to be 3 W at full load. The magnetising ampere-turns is 150.

Example 3.3

Solution Phasor diagram for the corresponding situation with purely resistive burden is shown in the figure.

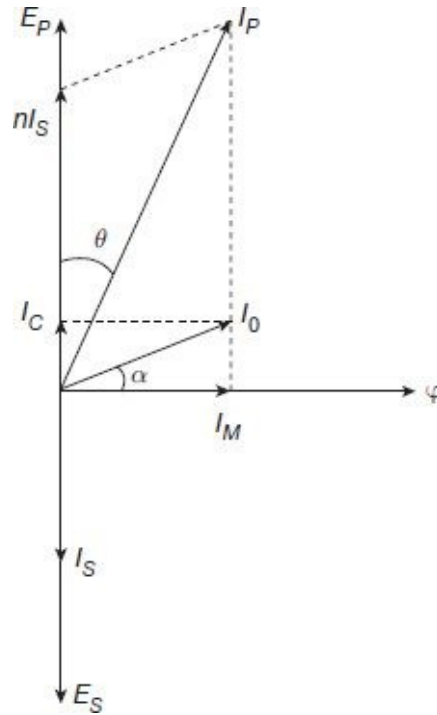

The burden being purely resistive, the secondary current I_S and secondary induced voltage E_S will be in the same phase as shown in the figure. Therefore, secondary winding power factor will be unity and the phase angle difference between I_S and E_S , $\delta = 0$.

$$\text{Nominal ratio } K_n = \frac{1500}{5} = 300$$

Without any turns compensation, nominal ratio equals the turns ratio, thus $n = K_n = 300$

Given, primary number of turns $N_P = 1$

Hence, secondary number of turns $N_S = n \cdot N_P = 300$

Given, secondary burden resistance = 1.5Ω .

Neglecting leakage flux and hence neglecting secondary leakage reactance, the total impedance of secondary circuit = 1.5Ω

Under full load rated condition, primary current = 1500 A and secondary current = 5 A .

$$\therefore \text{secondary induced voltage } E_S = 5 \times 1.5 = 7.5 \text{ V}$$

$$\text{And, primary induced voltage } E_P = E_S / n = 7.5 / 300 = 0.025 \text{ V}$$

From the relation, $E_S = 4.44 f \phi_m N_S$, the maximum flux can be calculated as

$$\phi_m = \frac{E_S}{4.44 f N_S} = \frac{7.5}{4.44 \times 50 \times 300} = 0.113 \times 10^{-3} \text{ Wb}$$

Given, iron loss at full load = 3 W

$$\therefore \text{loss component of current } I_C = \frac{\text{Iron loss}}{E_P} = \frac{3}{0.025} = 120 \text{ A}$$

$$\text{Magnetising component of current } I_M = \frac{\text{Magnetising mmf}}{N_P} = \frac{150}{1} = 150 \text{ A}$$

Noting the fact that for purely resistive burden $\delta = 0$

or,
$$R = 400 + \frac{80 \times 0.6 + 40 \times 0.8}{4} = 420$$

Percentage ratio error $= \frac{K_n - R}{R} \times 100\% = \frac{400 - 420}{420} \times 100\% = -4.76\%$

Phase-angle error $\theta \approx \frac{180}{\pi} \left(\frac{I_M \cos \delta - I_C \sin \delta}{n I_S} \right)$

or,
$$\theta = \frac{180}{\pi} \left(\frac{80 \times 0.8 - 40 \times 0.6}{400 \times 4} \right) = 3^\circ 9'$$

Example 3.5

A bar-type CT has 300 turns in the secondary winding. An ammeter connected to the secondary has a resistance of 1Ω and reactance of 0.8Ω , and the secondary winding impedance is $(0.5 + j0.6)\Omega$. The magnetising MMF requirement for the core is 60 A and to supply the iron loss the current required is 25 A. (a) Find the primary winding current and also determine the ratio error when the ammeter in the secondary winding shows 5 A. (b) How many turns should be reduced in the secondary to bring down ratio error to zero at this condition?

Solution

(a) Total resistance of secondary circuit $= 1 + 0.5 = 1.5 \Omega$

Total reactance of secondary circuit $= 0.8 + 0.6 = 1.4 \Omega$

\therefore secondary circuit phase angle $\delta = \tan^{-1} \left(\frac{1.4}{1.5} \right) = 43^\circ$

\therefore for secondary circuit, $\cos \delta = 0.73$ and $\sin \delta = 0.68$

Given, for bar-type CT, primary number of turns $N_P = 1$

Secondary number of turns $N_S = 300$

\therefore turns ratio $n = N_S / N_P = 300$

Without any turns compensation, nominal ratio equals the turns ratio, thus $K_n = n = 300$ Given, loss component of current $= I_c = 25 \text{ A}$

Magnetising current $I_M = \frac{\text{Magnetising mmf}}{N_P} = \frac{60}{1} = 60 \text{ A}$

\therefore transformation ratio $R \approx n + \frac{I_M \sin \delta + I_C \cos \delta}{I_S}$

or,
$$R = 300 + \frac{60 \times 0.68 + 25 \times 0.73}{5} = 311.8$$

\therefore ratio error $= \frac{K_n - R}{R} \times 100\% = \frac{300 - 311.8}{311.8} \times 100\% = -3.78\%$

Primary current $I_P = \text{Transformation ratio} \times \text{Secondary current} = R \times I_S$

$$\text{or, } I_p = 311.8 \times 4 = 1247.2 \text{ A}$$

- (b) To achieve zero ratio error, we must have the transformation ratio and nominal ratio to be equal.

$$\therefore R = Kn$$

$$\text{Thus, } n + \frac{I_M \sin \delta + I_C \cos \delta}{I_S} = 300, \text{ with } n = \text{the desired turns ratio}$$

$$\text{or, } 300 = n + \frac{60 \times 0.68 + 25 \times 0.73}{5} = n + 11.8$$

$$\text{or, } n = 288.2$$

$$\text{Thus, secondary number of turns required} = n \times N_p = 288.2 \times 1 = 288.2$$

$$\therefore \text{reduction in secondary winding turns} = 300 - 288.2 \approx 12$$

A bar-type CT with turns ratio 1:199 is rated as 2000:10 A, 50 VA. The magnetising and core loss components of primary current are 15 A and 10 A respectively under rated condition. Determine the ratio and phase angle errors for the rated burden and rated secondary current at 0.8 p.f. lagging and 0.8 p.f. leading. Neglect impedance of secondary winding.

Example 3.6

Solution Given, for bar-type CT. primary number of turns $N_p = 1$

$$\text{Turns ratio } n = N_s / N_p = 199$$

$$\therefore \text{secondary number of turns } N_s = 199$$

$$\text{Nominal ratio } K_n = 2000/10 = 200$$

$$\text{Given, loss component of current} = I_c = 10 \text{ A}$$

$$\text{Magnetising current } I_m = 15 \text{ A}$$

Power Factor = 0.8 lagging

For lagging p.f., the secondary phase angle δ is positive.

$$\text{Thus, } \cos \delta = 0.8 \text{ and } \sin \delta = \sqrt{1^2 - 0.8^2} = 0.6$$

$$\text{Transformation ratio } R \approx n + \frac{I_M \sin \delta + I_C \cos \delta}{I_S}$$

$$\text{or, } R = 199 + \frac{15 \times 0.6 + 10 \times 0.8}{10} = 200.7$$

$$\therefore \text{ratio error} = \frac{K_n - R}{R} \times 100\% = \frac{200 - 200.7}{200.7} \times 100\% = -0.35\%$$

$$\text{Phase-angle error } \theta \approx \frac{180}{\pi} \left(\frac{I_M \cos \delta - I_C \sin \delta}{n I_S} \right)$$

$$\text{or, } \theta = \frac{180}{\pi} \left(\frac{15 \times 0.8 - 10 \times 0.6}{199 \times 10} \right) = 10' 37''$$

Power Factor = 0.8 leading

For lagging p.f., the secondary phase angle δ is negative.

Thus, $\cos \delta = 0.8$ and $\sin \delta = -0.6$

$$\text{Transformation ratio } R \approx n + \frac{I_M \sin \delta + I_C \cos \delta}{I_S}$$

$$\text{or, } R = 199 + \frac{-15 \times 0.6 + 10 \times 0.8}{10} = 198.9$$

$$\therefore \text{ ratio error} = \frac{K_n - R}{R} \times 100\% = \frac{200 - 198.9}{198.9} \times 100\% = +0.55\%$$

$$\text{Phase-angle error } \theta \approx \frac{180}{\pi} \left(\frac{I_M \cos \delta - I_C \sin \delta}{n I_S} \right)$$

$$\text{or, } \theta = \frac{180}{\pi} \left(\frac{15 \times 0.8 + 10 \times 0.6}{199 \times 10} \right) = 31' 1''$$

3.9

POTENTIAL TRANSFORMERS (PT)

Measurement of voltage, power, etc., of high voltage lines requires the high level of voltage being stepped down before being applied to the measuring instrument. This is essential from the point of view of safety of operating personnel, reduction in size of instrument and saving in insulation cost. Potential transformers or PTs are used in such cases to operate voltmeters, potential coils of wattmeters, relays and other devices to be operated with high-voltage lines. The primary winding of the PT is connected across the high-voltage line whose voltage is to be measured and the measuring instruments are connected across the secondary of the PT. For all these purposes, it is essential that the secondary voltage be a definite fraction of the primary voltage, and in some applications they need to be in the same phase as well. Uses of PT for such applications are schematically shown in [Figure 3.14](#).

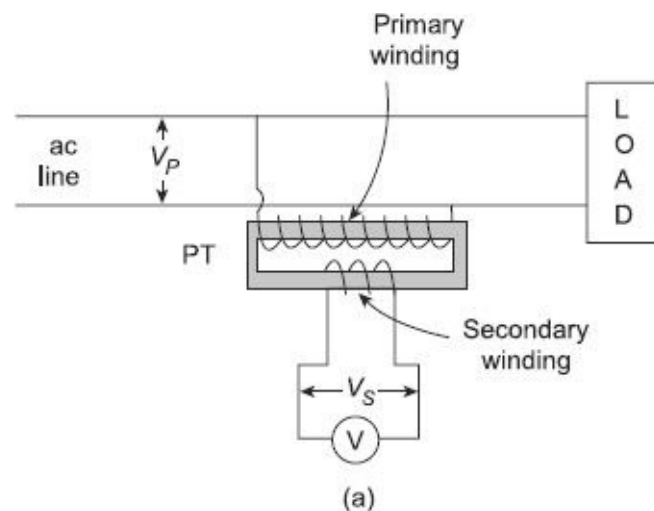

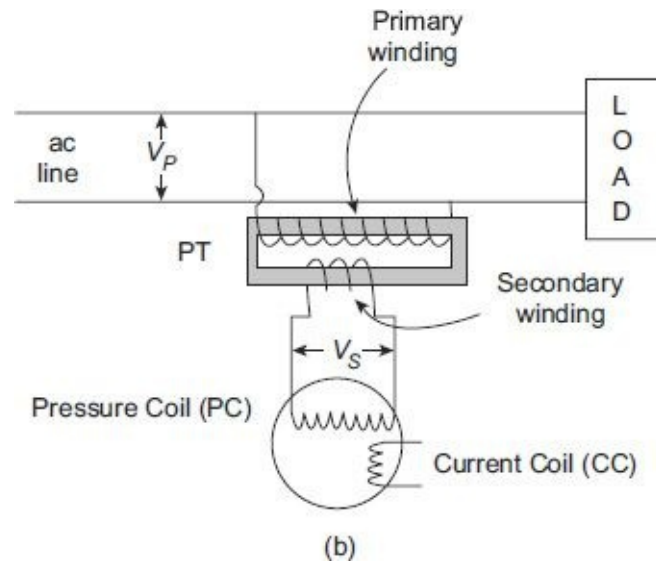

Figure 3.14 Use of PT for (a) voltage, and (b) power measurement

There is essentially no difference in theory between a PT used for measurement purposes and a power transformer for regular use. The main differences between a PT and a power transformer are actually special requirements for the measurement system. These are the following:

1. Attenuation ratio must be accurately maintained in a PT since it is being used for measurement purposes.
2. Voltage drops in the windings must be minimised in a PT in order to reduce effects of phase shift and ratio error. Voltage drops in windings can be reduced by proper design to minimise leakage reactance and using large copper conductors.
3. Loading in a PT is always small, only of the order of few volt-amperes. Loading of a PT is actually limited by accuracy considerations; whereas in a power transformer, load limitation is on a heating basis.
4. Overload capacity for PTs are designed to be up to 2-3 times their normal rated values. Whereas, high capacity power transformers, under special circumstances, can take up overloads up to only 20% above their normal rating.

3.10

THEORY OF POTENTIAL TRANSFORMERS

Figure 3.15 represent the equivalent circuit of a PT and Figure 3.16 plots the phasor diagram under operating condition of the PT.

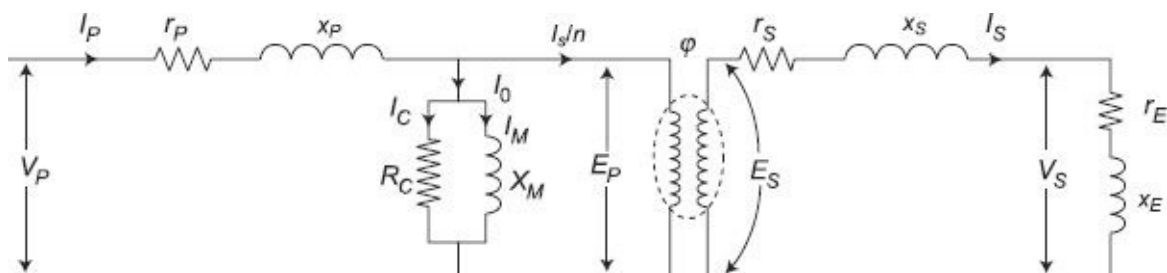

Figure 3.15 Equivalent circuit of a PT

V_P = primary supply voltage

E_P = primary winding induced voltage

V_S = secondary terminal voltage

E_S = secondary winding induced voltage

I_P = primary current

I_S = secondary current

I_0 = no-load current

I_C = core loss component of current

I_M = magnetising component of current

r_P = resistance of primary winding

x_P = reactance of primary winding

r_S = resistance of secondary winding

x_S = reactance of secondary winding

R_C = imaginary resistance representing core losses

X_M = magnetising reactance

r_E = resistance of external load (burden) including resistance of meters, current coils etc.

x_E = reactance of external load (burden) including reactance of meters, current coils, etc.

N_P = primary winding number of turns

N_S = secondary winding number of turns

n = turns ratio $= \frac{N_P}{N_S}$

ϕ = working flux of the PT

θ = the 'phase angle' of the PT

δ = phase angle between secondary winding terminal voltage and secondary winding current (i.e., phase angle of load circuit)

β = phase angle between primary load current and secondary terminal voltage reversed

α = phase angle between no-load current I_0 and flux ϕ

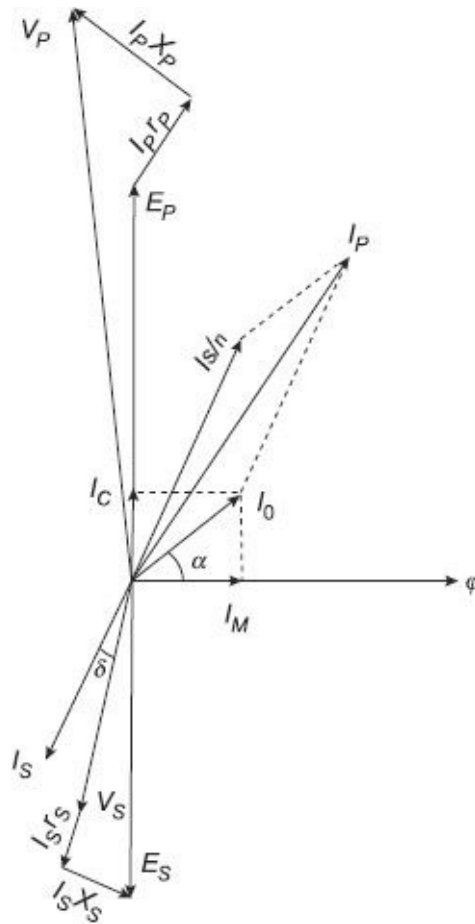

Figure 3.16 Phasor diagram of a PT

The flux \mathbf{j} is plotted along the positive x-axis. Magnetising component of current I_m is in phase with the flux. The core loss component of current I_C , leads by $I_M 90^\circ$. Summation of I_C and I_m produces the no-load current I_0 .

The primary winding induced voltage E_p is in the same phase with the resistive core loss component of current I_C . As per transformer principles, the secondary winding induced voltage E_s will be 180° out of phase with the primary winding induced voltage E_p . Secondary output terminal voltage V_s is obtained by vectorically subtracting the secondary winding resistive and reactive voltage drops $I_s r_s$ and $I_s X_s$ respectively from the secondary induced voltage E_s .

Secondary voltages when referred to primary side need to be multiplied by the turns ratio n , whereas, when secondary currents are to be referred to primary side, they need to be divided by n . Secondary current I_s , when reflected back to primary, can be represented by the 180° shifted phasor indicated by I_s/n . Primary winding current I_p is the phasor summation of this reflected secondary current (load component) I_s/n and the no-load current I_0 .

Vectorically adding the primary winding resistive and reactive voltage drops with the primary induced voltage will give the primary line voltage V_p .

3.10.1 Voltage Transformation Ratio of PT

Redrawing the expanded view of the phasor diagram of [Figure 3.14](#), we obtain the phasor

Substituting the above values in Eq. (3.12) we have,

$$V_P = nV_S + nI_S(r_S \cos \delta + x_S \sin \delta) + \left(I_C + \frac{I_S}{n} \cos \delta \right) r_P + \left(I_M + \frac{I_S}{n} \sin \delta \right) x_P$$

$$\text{or, } V_P = nV_S + I_S \cos \delta \left(nr_S + \frac{r_P}{n} \right) + I_S \sin \delta \left(nx_S + \frac{x_P}{n} \right) + (I_C r_P + I_M x_P) \quad (3.14)$$

$$\text{or, } V_P = nV_S + \frac{I_S}{n} \cos \delta (n^2 r_S + r_P) + \frac{I_S}{n} \sin \delta (n^2 x_S + x_P) + (I_C r_P + I_M x_P)$$

$$\text{or, } V_P = nV_S + \frac{I_S}{n} \cos \delta R_P + \frac{I_S}{n} \sin \delta X_P + (I_C r_P + I_M x_P)$$

$$\text{or, } V_P = nV_S + \frac{I_S}{n} (R_P \cos \delta + X_P \sin \delta) + (I_C r_P + I_M x_P) \quad (3.15)$$

Here, R_P = equivalent resistance of the PT referred to primary side

X_P = equivalent reactance of the PT referred to primary side

Thus, actual voltage transformation ratio:

$$R = \frac{V_P}{V_S} = n + \frac{\frac{I_S}{n} (R_P \cos \delta + X_P \sin \delta) + (I_C r_P + I_M x_P)}{V_S} \quad (3.16)$$

Equation (3.14) may be re-written as

$$V_P = nV_S + nI_S \cos \delta \left(r_S + \frac{r_P}{n^2} \right) + nI_S \sin \delta \left(x_S + \frac{x_P}{n^2} \right) + (I_C r_P + I_M x_P)$$

$$\text{or, } V_P = nV_S + nI_S \cos \delta R_S + nI_S \sin \delta X_S + (I_C r_P + I_M x_P)$$

$$\text{or, } V_P = nV_S + nI_S (R_S \cos \delta + X_S \sin \delta) + (I_C r_P + I_M x_P) \quad (3.17)$$

Here, R_S = equivalent resistance of the PT referred to secondary side

X_S = equivalent reactance of the PT referred to secondary side

Thus, actual voltage transformation ratio can again be written as

$$R = \frac{V_P}{V_S} = n + \frac{nI_S (R_S \cos \delta + X_S \sin \delta) + (I_C r_P + I_M x_P)}{V_S} \quad (3.18)$$

Following Eqs (3.16) and (3.18), the error in ratio, i.e., the difference between actual transformation ratio and turns ratio can be expressed in either of the following two

$$\text{forms: } R - n = \frac{\frac{I_S}{n} (R_P \cos \delta + X_P \sin \delta) + (I_C r_P + I_M x_P)}{V_S} \quad (3.19)$$

$$= \frac{nI_S (R_S \cos \delta + X_S \sin \delta) + (I_C r_P + I_M x_P)}{V_S} \quad (3.20)$$

3.10.2 Phase Angle of PT

From the phasor diagram of [Figure 3.17](#),

$$\tan \theta = \frac{ab}{oa} = \frac{I_P x_P \cos \beta - I_P r_P \sin \beta + nI_S}{nV_S + nI_S r_S \cos \delta + nI_S x_S \sin \delta}$$

To simplify the computations, here we can make the assumption that in the denominator, the terms containing I_P and I_S being much less compared to the large voltage

nV_S , those terms can be neglected; thus we get a simplified form:

$$\tan \theta = \frac{I_P x_P \cos \beta - I_P r_P \sin \beta + n I_S x_S \cos \delta - n I_S r_S \sin \delta}{n V_S} \quad (3.21)$$

Following Eq. (3.12), we get

$$\begin{aligned} \tan \theta &= \frac{x_P \left(I_C + \frac{I_S}{n} \cos \delta \right) - r_P \left(I_M + \frac{I_S}{n} \sin \delta \right) + n I_S x_S \cos \delta - n I_S r_S \sin \delta}{n V_S} \\ \text{or, } \tan \theta &= \frac{I_S \cos \delta \left(\frac{x_P}{n} + n x_S \right) - I_S \sin \delta \left(\frac{r_P}{n} + n r_S \right) + I_C x_P - I_M r_P}{n V_S} \\ \text{or, } \tan \theta &= \frac{\frac{I_S \cos \delta}{n} (x_P + n^2 x_S) - \frac{I_S \sin \delta}{n} (r_P + n^2 r_S) + I_C x_P - I_M r_P}{n V_S} \\ \text{or, } \tan \theta &= \frac{\frac{I_S \cos \delta}{n} X_P - \frac{I_S \sin \delta}{n} R_P + I_C x_P - I_M r_P}{n V_S} \\ \text{or, } \tan \theta &= \frac{\frac{I_S}{n} (X_P \cos \delta - R_P \sin \delta) + I_C x_P - I_M r_P}{n V_S} \end{aligned}$$

Since θ is small, we can assume $\tan \theta = \theta$; thus,

$$\theta = \frac{\frac{I_S}{n} (X_P \cos \delta - R_P \sin \delta) + I_C x_P - I_M r_P}{n V_S} \quad (3.22)$$

$$\text{or, } \theta = \frac{\frac{I_S}{n} (n^2 X_S \cos \delta - n^2 R_S \sin \delta) + I_C x_P - I_M r_P}{n V_S}$$

$$\text{or, } \theta = \frac{n I_S (X_S \cos \delta - R_S \sin \delta) + I_C x_P - I_M r_P}{n V_S}$$

$$\text{Thus, phase angle } \theta = \frac{I_S}{V_S} (X_S \cos \delta - R_S \sin \delta) + \frac{I_C x_P - I_M r_P}{n V_S} \quad (3.23)$$

3.11

ERRORS INTRODUCED BY POTENTIAL TRANSFORMERS

3.11.1 Ratio Error and Phase-Angle Error

It can be seen from the above section that, like current transformers, potential transformers also introduce errors in measurement. This error may be in terms of magnitude or phase, in the measured value of voltage. The ratio error (difference between nominal ratio and actual transformation ratio) only is important when measurements of voltage are to be made; the phase angle error is of importance only while measurement of power.

In presence of these errors, the voltage applied to the primary circuit of the PT can not be obtained accurately by simply multiplying the voltage measured by the voltmeter connected across the secondary by the turns ratio n of the PT.

These errors depend upon the resistance and reactance of the transformer winding as well as on the value of no-load current of the transformer.

3.11.2 Reducing Errors in PT

As discussed in the previous section, errors are introduced in the ratio and phase angle of a PT owing to the presence of the no-load component of the primary current and voltage drops across winding impedances. Improvement of accuracy, then, depends upon minimising these components or nullifying in some way their effects in introducing errors. This can be achieved by a combination of the following schemes:

1. Reducing the loss component and magnetising components, i.e., the no-load component of the primary current can be achieved by reducing the length of magnetic path in the core, using good quality core magnetic materials, designing with appropriate value of flux densities in the core, and adopting precautionary measures while assembling and interleaving of core laminations.
2. Winding resistance can be reduced by using thick conductors and taking care to reduce the length of mean turn of the windings.
3. Winding leakage flux and hence leakage reactance can be reduced by keeping the primary and secondary windings as close as permissible from the point of view of insulation requirements.
4. Sufficiently high flux densities in the core will reduce the core cross-section, thereby reducing the length of winding wound over the core. This, in turn, will reduce the winding resistance. An optimisation in the core flux density value to be used needs to be done, since too high a flux density will increase the no-load current, which is also not desirable.
5. From (3.18) it is clear that at no load, the actual PT transformation ratio exceeds the turns ratio by an amount $(I_C r_P + I_M X_P)/V_S$. With increased loading, this difference grows due to further voltage drops in winding resistance and reactance. If the turns ratio can be set at a value less than the nominal ratio, then the difference between nominal ratio and actual transformation ratio under operating condition can be brought down. This can be achieved by reducing the number of turns in the primary winding or increasing the number of turns in the secondary winding. This makes it possible to make the actual transformation ratio to be equal to the nominal ratio, at least for a particular value and type of burden.

3.12

OPERATIONAL CHARACTERISTICS OF POTENTIAL TRANSFORMERS

Characteristics of potential transformers under different operating conditions may be estimated from the phasor diagram as shown in [Figure 3.20](#) and expressions for ratio error (3.19) and phase-angle error (3.22).

3.12.1 Effect of Change in Secondary Burden (VA or Current)

With increase in PT secondary burden, the secondary current is increased. This in turn will increase the primary current as well. Both primary and secondary voltage drops are increased and hence, for a given value of the primary supply voltage V_P , secondary terminal voltage V_S is reduced with increase of burden. The effect is therefore to increase the actual transformation ratio V_P/V_S with resulting increase in the ratio error as per Eq. (3.19). This increase in ratio error with increasing secondary burden is almost linear as shown in Figure 3.18.

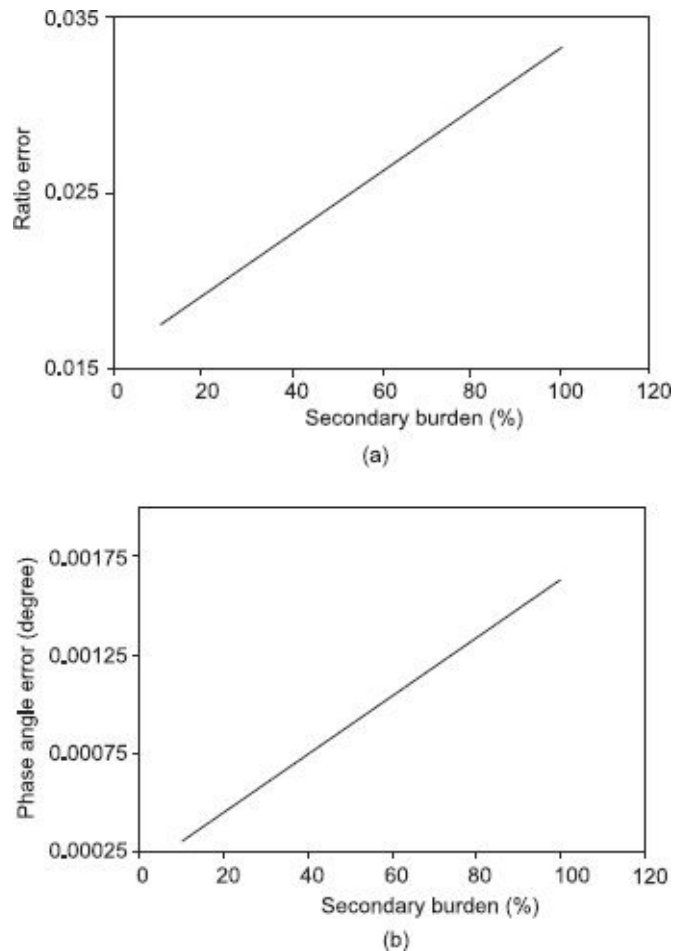

Figure 3.18 Effects of secondary burden variation on (a) PT ratio error, and (b) PT phase angle error

With regard to the phase angle, with increasing voltage drops due to increased burden, the phase difference between V_P and V_S reversed increases with resulting increase in phase angle error. Such a variation of phase-angle error with varying secondary burden in a typical potential transformer is shown in Figure 3.18.

3.12.2 Effect of Change in Power Factor of Secondary Burden

As can be observed from the phasor diagram of potential transformer in Figure 3.18, for all inductive burdens, the secondary winding current I_S lags behind the secondary terminal voltage V_S , so that the phase angle difference δ is positive. At lower power factors, this phase angle difference δ increases as I_S moves further away from V_S . Thus, from the phasor diagram, it is apparent that I_p will now become closer to I_0 . This will, in turn, move V_P and V_S more towards to be in phase with E_P and E_S respectively. It is to be kept in mind that change in power factor does not affect the magnitudes of resultant voltage drops in primary and secondary windings substantially. Under these conditions, with primary

supply voltage V_p being considered to remain the same, there is a reduction of E_p relative to V_p , and V_s relative to E_s . The actual transformation ratio V_p / V_s of the potential transformer will thus increase with reduction in burden power factor.

Further, since V_s is advanced in phase and V_p is retarded in phase, the phase angle of the transformer (between V_s and V_p) is reduced with reduction in burden (inductive) power factor.

Figure 3.19 shows the variations of ratio and phase-angle errors in a typical current transformer at different values of the secondary burden power factor.

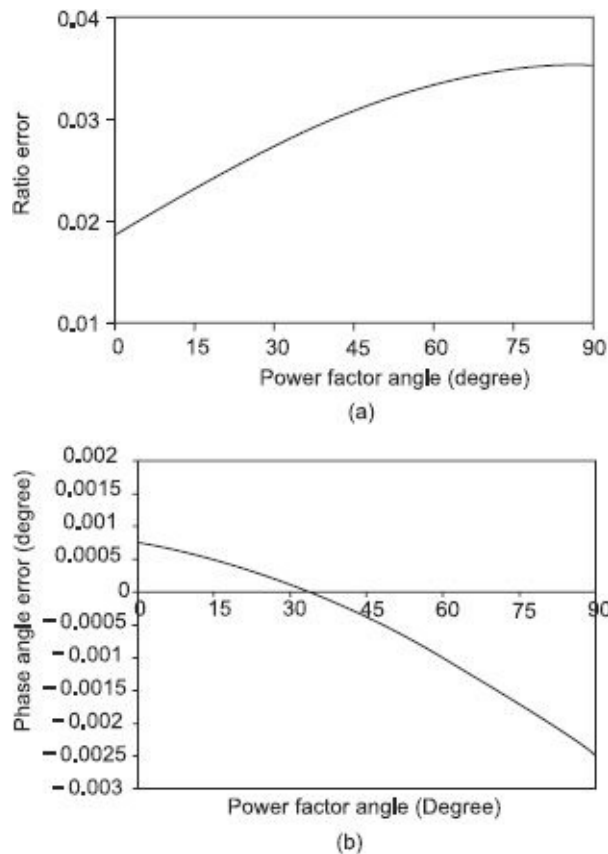

Figure 3.19 Effects of secondary burden power factor variation on (a) PT ratio error, and (b) PT phase angle error

3.13

DESIGN AND CONSTRUCTIONAL FEATURES OF POTENTIAL TRANSFORMERS

1. Core

The core construction of a PT may be of shell type or core type. Core-type construction is only used for low voltage applications. Special care is taken during interleaving and assembling of the core laminations so that minimal air gap is present in the stack joints.

2. Winding

The primary and secondary windings are made coaxial to restrict the leakage reactance to a minimum. In simplifying assembly and reducing insulation requirement, the low-voltage

secondary winding is placed nearer to the core, with the high-voltage primary being wound over the secondary. For lower voltage rating the high-voltage primary winding can be made of a single coil, but for higher voltages, however, a number of separate coils can be assembled together to reduce insulation complicacies.

3. Insulation

Cotton tape and varnish is the most common insulation applied over windings during coil construction. At low voltages, PTs are usually filled with solid compounds, but at higher voltages above 7-10 kV, they are oil-immersed.

4. Bushings

Oil-filled bushings are normally used for oil filled potential transformers as this reduces the overall height. Some potential transformers connected between line and neutral of a grounded neutral system have only one bushing for the high voltage terminal. Some potential transformers can have two bushings when neither side of the line is at ground potential. A view of such a two-bushing potential transformer is shown in [Figure 3.20](#).

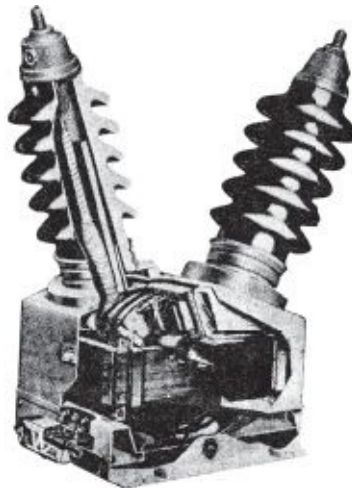

Figure 3.20 *Cutaway view of two-bushing type potential transformer (Courtesy of Westinghouse Electric Corp.)*

5. Cost and Size

Power transformers are designed keeping in view the efficiency, regulation and cost constraints. The cost in such cases is reduced by using smaller cores and conductor sizes. In potential transformers, however, cost cannot be compromised with respect to desired performance and accuracy. Accuracy requirements in potential transformers in terms of ratio and phase angle obviate the use of good quality and amount of magnetic material for the core and also thick conductors for the winding.

6. Overload Capacity

Potential transformers are normally designed for very low power ratings and relatively large weight/ power ratio as compared to a power transformer. Theoretically, this can enable a potential transformer to run on appreciable overloads without causing much heating. Overload capacities of potential transformers are, however, limited by accuracy

requirements, rather than heating.

Example 3.1

A potential transformer with nominal ratio 1100/110 V has the following parameters:

Primary resistance = 82 Ω secondary resistance = 0.9 Ω

Primary reactance = 76 Ω secondary reactance = 0.72 Ω

No load current = 0.02 A at 0.4 power factor

Calculate (a) phase angle error at no load

(b) burden in VA at unity power factor at which phase angle error will be zero

Solution No load power factor = $\cos(90^\circ + \alpha) = 0.4$

$$\alpha = 23.6^\circ \text{ and } \sin \alpha = 0.4, \cos \alpha = 0.917$$

$$I_C = I_0 \sin \alpha = 0.02 \times 0.4 = 0.008 \text{ A}$$

$$I_M = I_0 \cos \alpha = 0.02 \times 0.917 = 0.0183 \text{ A}$$

$$\text{Turns ratio } n = 1100/110 = 10$$

$$\text{From Eq. (3.21), } \theta = \frac{\frac{I_S}{n}(X_P \cos \delta - R_P \sin \delta) + I_C x_P - I_M r_P}{nV_S} \text{ rad}$$

(a) At no load, $I_S = 0$

$$\therefore \theta = \frac{I_C x_P - I_M r_P}{nV_S} = \frac{0.008 \times 76 - 0.0183 \times 82}{10 \times 100} = -3'06''$$

(b) At unity power factor, $\delta = 0$; thus $\cos \delta = 1$ and $\sin \delta = 0$

$$\text{From the equation, } \theta = \frac{\frac{I_S}{n}(X_P \cos \delta - R_P \sin \delta) + I_C x_P - I_M r_P}{nV_S} \text{ we have}$$

$$\theta = \frac{\frac{I_S}{n}(X_P \cos \delta) + I_C x_P - I_M r_P}{nV_S}$$

For zero phase-angle error, $\theta = 0$;

$$\text{Thus, } \theta = \frac{\frac{I_S}{n}(X_P \cos \delta) + I_C x_P - I_M r_P}{nV_S} = 0$$

$$\text{or, } I_S = (I_M r_P - I_C x_P) \frac{n}{X_P}$$

X_P - Total impedance referred to primary - $x_P + n \times X_S$

$$\text{or, } x_P = 76 + 10^2 \times 0.72 = 148 \Omega$$

$$\text{Thus, or, } I_S = (0.0183 \times 82 - 0.008 \times 76) \frac{10}{148} = 0.06 \text{ A}$$

$$\text{secondary burden} = V_S \times I_S = 110 \times 0.06 = 6.6 \text{ VA}$$

A potential transformer rated at 6600/110 V has 24000

Example 3.8

turns in the primary and 400 turns in the secondary winding. With rated voltage applied to the primary and secondary circuit opened, the primary winding draws a current of 0.004 A, lagging the voltage by 75°. In another operating condition with a certain burden connected to the secondary, the primary draws 0.015 A at an angle 60° lagging with respect to the voltage. The following parameters are given for the transformer:

Primary resistance = 600 Ω

secondary resistance = 0.6 Ω

Primary reactance = 1500 Ω

secondary reactance = 0.96 Ω

Calculate (a) Secondary load current and terminal voltage, using rated applied voltage as the reference

(b) The load burden in this condition

(c) Actual transformation ratio and phase angle

(d) How many turns should be changed in the primary winding to make the actual ratio equal to the nominal ratio under such operating condition?

Solution The corresponding phasor diagram is shown in the figure.

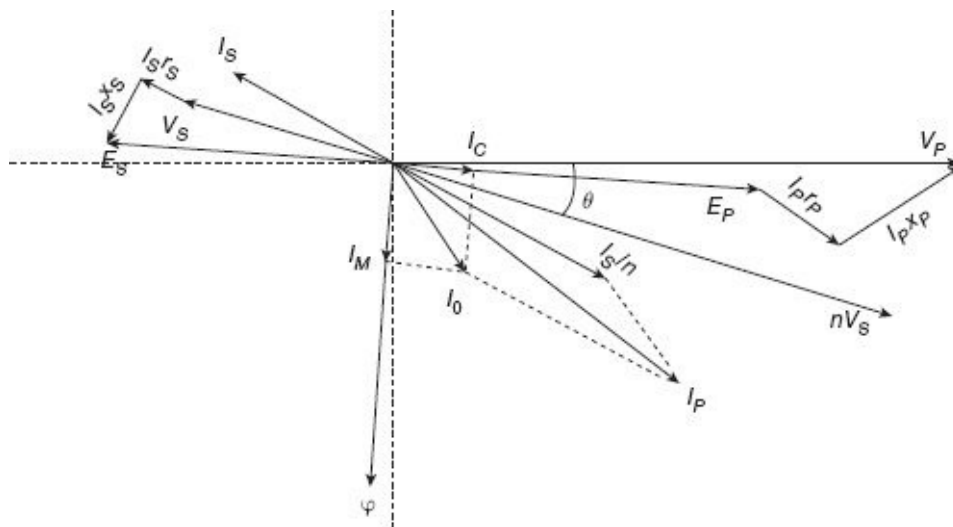

Nominal ratio = 6600/110 = 60 Turns ratio = 24000/400 = 60 No load current = 0.004 A

No load power factor = $\cos 75^\circ = 0.26$ and $\sin 75^\circ = 0.966$ Primary current = 0.015 A

Primary power factor = $\cos 60^\circ = 0.5$ and $\sin 60^\circ = 0.866$

Primary voltage V_P is taken as reference

Thus, $V_P = 6600 + j0$

$$I_P = 0.015(0.5 - j0.866) = 0.0075 - j0.013$$

$$I_0 = 0.004(0.26 - j0.966) = 0.00104 - j0.0039$$

As seen from [Figure 3.21](#), the phasor $\frac{I_S}{n}$ is the phasor difference of I_P and I_0 .

Thus, $\frac{I_S}{n} = (0.0075 - j0.013) - (0.00104 - j0.0039) = 0.00646 - j0.0091$

Thus, I_S (reversed) = $60 \times (0.00646 - j0.0091) = 0.388 - j0.546$

secondary current phasor $I_S = -(0.388 - j0.546) = -0.388 + j0.546$

(a) Secondary current magnitude $I_S = \sqrt{(0.388)^2 + (0.546)^2} = 0.67$ A Primary voltage

$$E_P = V_P - I_P \times Z_P$$

or, $E_P = 6600 + j0 - (0.0075 - j0.013)(600 + j1500)$

or, $E_P = 6576 - j3.45$

Secondary induced voltage (reversed)

$$E_S(\text{reversed}) = \frac{E_P}{n} = \frac{6576 - j3.45}{60} = 109.6 - j0.0575$$

secondary induced voltage phasor = $E_S = -(-109.6 - j0.0575)$

or, $E_S = -109.6 + j0.575$

secondary terminal voltage

$$V_S = E_S - I_S \times Z_S$$

$$= -109.6 + j0.575 - (-0.388 + j0.546)(0.6 + j0.96)$$

$$= -109.9 + j0.76$$

magnitude of secondary terminal voltage

$$V_S = \sqrt{(109.9)^2 + (0.76)^2} = 109.9 \text{ A}$$

(b) Secondary load burden = $V_S \times I_S = 109.9 \times 0.67 = 73.63$ VA

(c) Actual transformation ratio $R = \frac{V_P}{V_S} = \frac{6600}{109.9} = 60.055$

V_S (reversed) = $-(-109.9 + j0.76) = 109.9 - j0.76$ V

Phase angle by which V_S (reversed) lags V_P

$$\theta = \frac{180}{\pi} \times \tan^{-1} \left(\frac{0.76}{109.9} \right) = 23.7'$$

(d) In order to make actual ratio equal to the nominal ratio, the primary number of turns should be reduced to

3.14

DIFFERENCES BETWEEN CT AND PT

In summary, the following differences between a current transformer (CT) and a potential transformer (PT) can be tabulated:

<i>CT</i>	<i>PT</i>
Reduce the main power line current to be measured by normal range instruments, i.e. current is stepped down from primary to secondary	Reduce the main power line voltage to be measured by normal range instruments, i.e. voltage is stepped down from primary to secondary
Primary winding of CT is connected in series with the main power line to sense current	Primary winding of PT is connected across (in parallel with) the main power line to sense voltage
Primary winding has less number of turns as compared to the secondary winding	Primary winding has more number of turns as compared to the secondary winding
CT secondary side should never be open circuited while energised, to restrict accidental over-voltage	PT secondary can be safely open circuited even if the PT is energized, since secondary voltage is always restricted by the turns ratio
In many cases, such as in bar type, in single primary winding type and in clamp-on type CT, the primary winding is nothing but the main power line conductor itself	In all the PTs, separate primary as well as secondary windings are necessary. Primary winding terminals are connected across the main power line (in parallel)
While using CT for measurement of power, secondary winding is connected in series with the current coil of the wattmeter	While using PT for measurement of power, secondary winding is connected in parallel with the pressure coil of the wattmeter

EXERCISE

Objective-type Questions

- The disadvantages of using shunts for high current measurements are
 - power consumption by the shunts themselves is high
 - it is difficult to achieve good accuracy with shunts at high currents
 - the metering circuit is not electrically isolated from the power circuit
 - all of the above
- The disadvantages of using multipliers with voltmeters for measuring high voltages are
 - power consumption by multipliers themselves is high at high voltages
 - multipliers at high voltage need to be shielded to prevent capacitive leakage
 - the metering circuit is not electrically isolated from the power circuit
 - all of the above
- The advantages of instrument transformers are
 - the readings of instruments used along with instrument transformers rarely depend on the impedance of the instrument
 - due to availability of standardised instrument transformers and associated instruments, there is reduction in cost and ease of replacement
 - the metering circuit is electrically isolated from the power circuit
 - all of the above
- Nominal ratio of a current transformer is
 - ratio of primary winding current to secondary winding current
 - ratio of rated primary winding current to rated secondary winding current
 - ratio of number of turns in the primary to number of turns in the secondary
 - all of the above
- Burden of a CT is expressed in terms of
 - secondary winding current
 - VA rating of the transformer

- (c) power and power factor of the secondary winding circuit
 - (d) impedance of secondary winding circuit
6. Ratio error in a CT is due to
- (a) secondary winding impedance (b) load impedance
 - (c) no load current (d) all of the above
7. Phase-angle error in a CT is due to
- (a) primary winding impedance
 - (b) primary circuit phase angle
 - (c) leakage flux between primary and secondary
 - (d) all of the above
8. Errors in instrument transformers can be aggravated by
- (a) leakage flux (b) core saturation
 - (c) transients in main power line (d) all of the above
9. Phase-angle error in a CT can be reduced by
- (a) reducing number of secondary turns
 - (b) using thin conductors for the primary winding
 - (c) using good quality, low loss steel for core
 - (d) all of the above
10. Ratio error in a CT can be reduced by
- (a) using good quality, low loss steel for core
 - (b) placing primary and secondary windings closer to each other
 - (c) using thick conductors for secondary winding
 - (d) all of the above
11. Flux density in instrument transformers must be designed to be
- (a) sufficiently low to reduce core losses
 - (b) sufficiently high to reduce core section and hence reduce length of winding
 - (c) sufficiently low to prevent core saturation
 - (d) properly optimized to have a balance among (a)-(c)
12. Current in the primary winding of CT depends on
- (a) burden in the secondary winding of the transformer
 - (b) load connected to the system in which the CT is being used for measurement
 - (c) both burden of the secondary and load connected to the system
 - (d) none of the above
13. Turns compensation is used in CT to reduce
- (a) phase-angle error
 - (b) both ratio and phase angle error
 - (c) primarily ratio error, reduction in phase angle error is incidental
 - (d) none of the above
14. Secondary winding of CT should never be open circuited with primary still energised because that will
- (a) increase power loss in the secondary winding
 - (b) increase terminal voltage in the secondary winding
 - (c) increase the leakage flux manifolds

- (d) all of the above
15. Open circuiting the secondary winding of CT with primary still energised will result in
- unrestricted primary flux to generate high voltages across secondary terminals
 - possible insulation damage due to high voltage being generated
 - injury to careless operator
 - all of the above
16. A short-circuiting link is provided on the secondary side of a CT to
- allow high current to flow in the primary when the secondary winding of the CT is short circuited with the link
 - allow adjustments to be made in the secondary side, like replacing the ammeter, with the primary energized but the short circuiting link in use
 - enable primary current to drop down to zero when the secondary is open circuited with the short circuiting link in use
 - all of the above
17. Clamp-on type and split-core type CTs are used because
- their accuracy is high
 - it is possible to insert the CT in the circuit without breaking the main line
 - they are cheaper
 - all of the above
18. Transformation ratio of a PT is defined as
- ratio of primary winding voltage to secondary winding voltage
 - ratio of rated primary winding voltage to rated secondary winding voltage
 - ratio of primary number of turns to secondary number of turns
 - all of the above
19. When the secondary winding of a PT is suddenly open circuited with the primary winding still open circuited then
- large voltages will be produced across the secondary terminals that may be dangerous for the operating personnel
 - large voltages thus produced may damage the insulation
 - the primary winding draws only no-load current
 - none of the above
20. The size of a PT as compared to a power transformer of same VA
- is smaller (b) is bigger
 - is the same (d) there is no relation as such

Answers						
1. (d)	2. (d)	3. (a)	4. (b)	5. (b)	6. (d)	7. (c)
8. (d)	9. (d)	10. (d)	11. (d)	12. (b)	13. (c)	14. (b)
15. (d)	16. (d)	17. (b)	18. (a)	19. (c)	20. (a)	

Short-answer Questions

- Discuss the advantages of instrument transformers as compared to shunts and multipliers for extension of instrument range.
- Describe with clear schematic diagrams, how high voltage and currents are measured with the help of instrument transformers.
- Draw and explain the nature of equivalent circuit the and corresponding phasor diagram of a current transformer.

4. Discuss the major sources of error in a current transformer.
5. Describe the design and constructional features of a current transformer for reducing ratio error and phase-angle error.
6. Explain with the help of a suitable example, the method of turns compensation in a CT to reduce ratio error.
7. Why should the secondary winding of a CT never be open circuited with its primary still energised?
8. Explain how the core of a CT may get permanent magnetisation induced in it. What are the bad effects of such permanent magnetisation? What are the ways to de-magnetise the core in such situations?
9. Draw and explain the constructional features of wound-type, bar type, clamp type and bushing type CTs.
10. Draw the equivalent circuit and phasor diagram of a potential transformer being used for measurement of high voltages.
11. What are the differences between a potential transformer and a regular power transformer?
12. Describe the methods employed for reducing ratio error and phase angle error in PTs.

Long-answer Questions

1. Draw and explain the nature of equivalent circuit and corresponding phasor diagram of a current transformer. Derive expressions for the corresponding ratio error and phase angle error.
2. (a) What are the sources of error in a current transformer?
 (b) A ring-core type CT with nominal ratio 1000/5 and a bar primary has a secondary winding resistance of 0.8Ω and negligible reactance. The no load current is 4 A at a power factor of 0.35 when full load secondary current is flowing in a burden of 1.5Ω non-inductive resistance. Calculate the ratio error and phase-angle error at full load. Also calculate the flux in the core at 50 Hz.
3. (a) Describe the design and constructional features of a current transformer for reducing ratio error and phase-angle error.
 (b) A 1000/10 A, 50 Hz single-turn primary type CT has a secondary burden comprising of a pure resistance of 1.0Ω . Calculate flux in the core, ratio error and phase-angle error at full load. Neglect leakage reactance and assume the iron loss in the core to be 5 W at full load. The magnetising ampere-turns is 180.
4. (a) Why the secondary winding of a CT should never be open circuited with its primary still energised?
 (b) A bar-type CT has 300 turns in the secondary winding. The impedance of the secondary circuit is $(1.5 + j2)\Omega$. With 5 A flowing in the secondary, the magnetising mmf is 1000 A and the iron loss is Determine ratio and phase-angle errors.
5. (a) Explain the method of turns compensation in a CT to reduce ratio error.
 (b) A bar-type CT has 400 turns in the secondary winding. An ammeter connected to the secondary has resistance of 1.5Ω and reactance of 1.0Ω , and the secondary winding impedance is $(0.6 + j0.8) \Omega$. The magnetising mmf requirement for the core is 80 A and to supply the iron loss the current required is 30 A. (i) Find the primary winding current and also determine the ratio error when the ammeter in the secondary winding shows 4 A. (ii) How many turns should be reduced in the secondary to bring down ratio error to zero at this condition?
6. Draw and explain the nature of equivalent circuit and corresponding phasor diagram of a potential transformer. Derive expressions for the corresponding ratio error and phase-angle error.
7. (a) What are the differences between a potential transformer and a regular power transformer?
 (b) A potential transformer with nominal ratio 1000/100 V has the following parameters:
 Primary resistance = 96Ω secondary resistance = 0.8Ω
 Primary reactance = 80Ω secondary reactance = 0.65Ω
 No load current = 0.03 a at 0.35 power factor Calculate
 (i) phase angle error at no load
 (ii) burden in VA at unity power factor at which phase angle error will be zero.
- (a) Describe the methods employed for reducing ratio error and phase angle error in PTs?

- (b) A potential transformer rated at 6000/100 V has 24000 turns in the primary and 400 turns in the secondary winding. With rated voltage applied to the primary and secondary circuit opened, the primary winding draws a current of 0.005 A lagging the voltage by 70° . In another operating condition with a certain burden connected to the secondary, the primary draws 0.012 A at an angle 54° lagging with respect to the voltage. The following parameters are given for the transformer:

Primary resistance = 600Ω

secondary resistance = 0.6Ω

Primary reactance = 1500Ω

secondary reactance = 0.96Ω

Calculate

- (i) Secondary load current and terminal voltage, using rated applied voltage as the reference
- (ii) The load burden in this condition
- (iii) Actual transformation ratio and phase angle
- (iv) How many turns should be changed in the primary winding to make the actual ratio equal to the nominal ratio under such operating condition?

4

Measurement of Resistance

4.1

INTRODUCTION

Resistors are used in many places in electrical circuits to perform a variety of useful tasks. Properties of resistances play an important role in determining performance specifications for various circuit elements including coils, windings, insulations, etc. It is important in many cases to have reasonably accurate information of the magnitude of resistance present in the circuit for analysing its behaviour. Measurement of resistance is thus one of the very basic requirements in many working circuits, machines, transformers, and meters. Apart from these applications, resistors are used as standards for the measurement of other unknown resistances and for the determination of unknown inductance and capacitance.

From the point of view of measurement, resistances can be classified as follows:

1. Low Resistances

All resistances of the order less than 1Ω may be classified as low resistances. In practice, such resistances can be found in the copper winding in armatures, ammeter shunts, contacts, switches, etc.

2. Medium Resistances

Resistances in the range 1Ω to $100 \text{ k}\Omega$ may be classified as medium resistances. Most of the electrical apparatus used in practice, electronic circuits, carbon resistance and metal-film resistors are found to have resistance values lying in this range.

3. High Resistances

Resistances higher than $100 \text{ k}\Omega$ are classified as high resistances. Insulation resistances in electrical equipment are expected to have resistances above this range.

The above classifications are, however, not rigid, but only form a guideline for the method of measurement to be adopted, which may be different for different cases.

4.2

MEASUREMENT OF MEDIUM RESISTANCES

The different methods for measurement of medium range resistances are (i) ohmmeter method, (ii) voltmeter–ammeter method, (iii) substitution method, and (iv) Wheatstone-bridge method.

4.2.1 Ohmmeter Method for Measuring Resistance

Ohmmeters are convenient direct reading devices for measurement of approximate resistance of circuit components without concerning too much about accuracy. This instrument is, however, very popular in the sense that it can give quick and direct readings for resistance values without any precise adjustments requirements from the operator. It is also useful in measurement laboratories as an adjunct to a precision bridge. Value of the unknown resistance to be measured is first obtained by the ohmmeter, and this can save lot of time in bridge balancing for obtaining the final precision value using the bridge.

Series-type Ohmmeter

Figure 4.1 shows the elements of a simple single-range series-type ohmmeter.

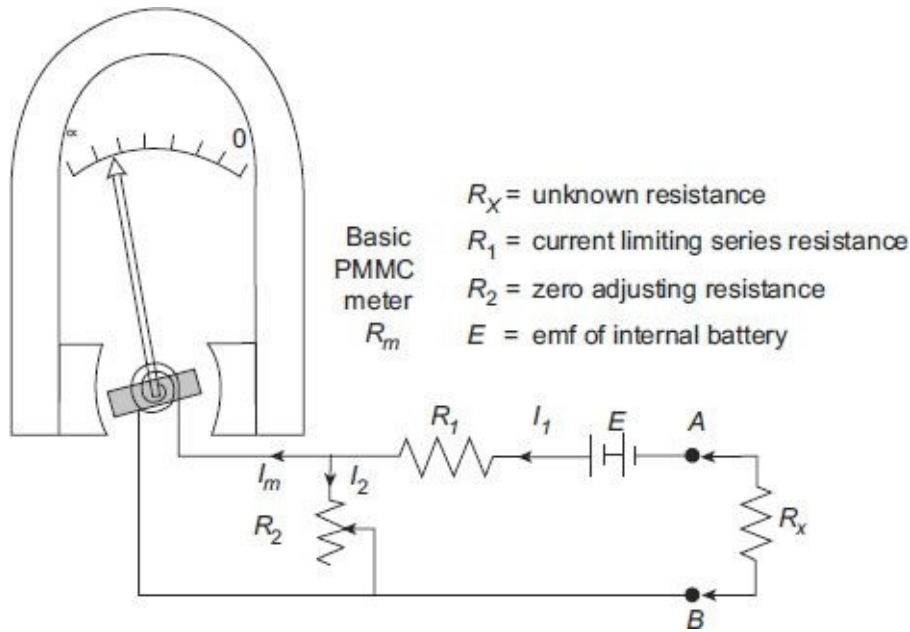

Figure 4.1 Single-range series ohmmeter

The series-type ohmmeter consists basically of a sensitive dc measuring PMMC ammeter connected in parallel with a variable shunt R_2 . This parallel circuit is connected in series with a current limiting resistance R_1 and a battery of emf E . The entire arrangement is connected to a pair of terminals ($A-B$) to which the unknown resistance R_x to be measured is connected.

Before actual readings are taken, the terminals $A-B$ must be shorted together. At this position with $R_x = 0$, maximum current flows through the meter. The shunt resistance R_2 is adjusted so that the meter deflects corresponding to its right most full scale deflection (FSD) position. The FSD position of the pointer is marked 'zero-resistance', i.e., 0Ω on the scale. On the other hand, when the terminals $A-B$ are kept open ($R_x \rightarrow \infty$), no current flows through the meter and the pointer corresponds to the left most zero current position on the scale. This position of the pointer is marked as ' $\infty \Omega$ ' on the scale. Thus, the meter will read infinite resistance at zero current position and zero resistance at full-scale current position. Series ohmmeters thus have '0' mark at the extreme right and ' ∞ ' mark at the extreme left of scale (opposite to those for ammeters and voltmeters).

The main difficulty is the fact that ohmmeters are usually powered by batteries, and the

battery voltage gradually changes with use and age. The shunt resistance R_2 is used in such cases to counteract this effect and ensure proper zero setting at all times.

For zero setting, $R_x = 0$, where R_m = internal resistance of the basic PMMC meter coil

$$\therefore \text{equivalent resistance of the circuit } R_{eq} = R_1 + \frac{R_2 R_m}{R_2 + R_m}$$

$$\text{And, total current } I_1 = \frac{E}{R_{eq}} = I_2 + I_m$$

The current I_2 can be adjusted by varying R_2 so that the meter current I_m can be held at its calibrated value when the main current I_1 changes due to drop in the battery emf E .

If R_2 were not present, then it would also have been possible to bring the pointer to full scale by adjustment of the series resistance R_1 , But this would have changed the calibration all along the scale and cause large error..

(i) Design of R_1 and R_2 The extreme scale markings, i.e., 0 and ∞ , in an ohmmeter do not depend on the circuit constants. However, distributions of the scale markings between these two extremes are affected by the constants of the circuit. It is thus essential to design for proper values of the circuit constants, namely, R_1 and R_2 in particular to have proper calibration of the scale. The following parameters need to be known for determination of R_1 and R_2 .

- Meter current I_m at full scale deflection ($= I_{FSD}$.)
- Meter coil resistance, R_m
- Ohmmeter battery voltage, E
- Value of the unknown resistance at half-scale deflection, (R_h), i.e., the value of R_x when the pointer is at the middle of scale

With terminals A–B shorted, when $R_x = 0$

Meter carries maximum current, and current flowing out of the battery is given as

$$I_{1MAX} = \frac{E}{R_i}$$

where R_i = internal resistance of the ohmmeter $= R_1 + \frac{R_2 R_m}{R_2 + R_m}$

At half-scale deflection, $R_x = R_h$, and $I_h = \frac{I_{1MAX}}{2} = \frac{E}{R_i + R_h}$

$$\therefore \frac{E}{R_i + R_h} = \frac{E}{2R_i}$$

$$\text{or, } R_i = R_h$$

$$\therefore I_h = \frac{E}{2R_h} \text{ and } R_h = R_i = R_1 + \frac{R_2 R_m}{R_2 + R_m}$$

For full-scale deflection,

$$I_h = I_{FSD} \text{ and } I_1 = 2I_h = 2 \times \frac{E}{2R_h} = \frac{E}{R_h}$$

Also, $I_m R_m = I_2 R_2$ and $I_2 = I_1 - I_m$

$$\therefore \text{At FSD, } I_{FSD} R_m = R_2 (I_1 - I_m) = R_2 \left(\frac{E}{R_h} - I_{FSD} \right)$$

Thus,

$$R_2 = \frac{I_{FSD} R_m R_h}{(E - I_{FSD} R_h)} \quad (4.1)$$

Again, since $R_h = R_i = R_1 + \frac{R_2 R_m}{R_2 + R_m}$, putting the value of R_2 from (4.1), we get

$$R_1 = R_h - \frac{I_{FSD} R_m R_h}{E} \quad (4.2)$$

(ii) . Shape of Scale in Series Ohmmeters Electrical equivalent circuit of a series-type ohmmeter is shown in [Figure 4.2](#).

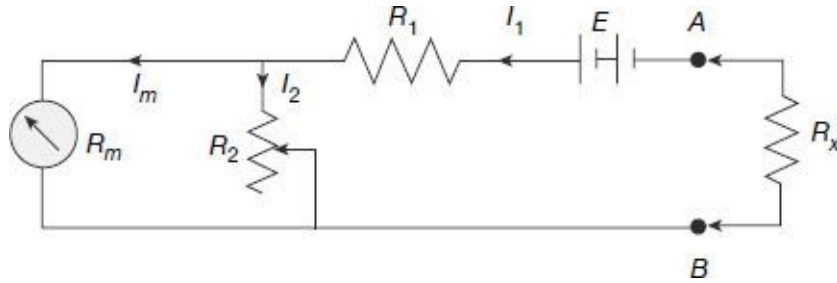

Figure 4.2 Electrical equivalent circuit of a series-type ohmmeter

Internal resistance of the ohmmeter

$$R_i = R_1 + \frac{R_2 R_m}{R_2 + R_m}$$

Thus, $I_1 = \frac{E}{R_i + R_x}$

Meter current $I_m = I_1 \times \frac{R_2}{R_2 + R_m} = \frac{E}{R_i + R_x} \times \frac{R_2}{R_2 + R_m}$

With the terminals A–B short circuited $R_x = 0$; thus, from (4.3) we have

$$I_{FSD} = \frac{E}{R_i} \times \frac{R_2}{R_2 + R_m} \quad (4.4)$$

From (4.3) and (4.4), the meter can be related to the FSD as

$$\frac{I_m}{I_{FSD}} = \frac{\frac{E}{R_i + R_x} \times \frac{R_2}{R_2 + R_m}}{\frac{E}{R_i} \times \frac{R_2}{R_2 + R_m}} = \frac{R_i}{R_i + R_x}$$

Thus,

$$I_m = \frac{R_i}{R_i + R_x} \times I_{FSD} \quad (4.5)$$

From Eq. (4.5), it can be observed that the meter current I_m is not related linearly with the resistance R_x to be measured. The scale (angle of deflection) in series ohmmeter if

thus non-linear and cramped.

The above relation (4.5) also indicates the fact that the meter current and hence graduations of the scale get changed from the initial calibrated values each time the shunt resistance R_2 is adjusted. A superior design is found in some ohmmeters where an adjustable soft-iron shunt is placed across the pole pieces of the meter, as indicated in Figure 4.3.

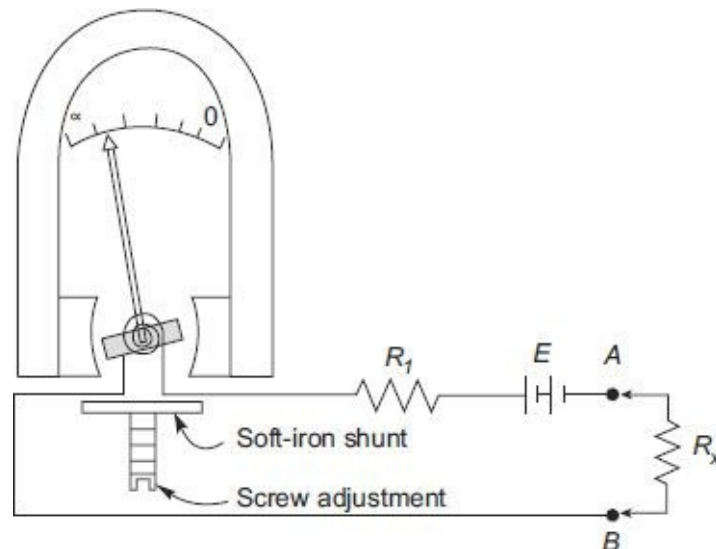

Figure 4.3 Series ohmmeter with soft-iron magnetic shunt

The soft-iron magnetic shunt, when suitably positioned with the help of screw adjustment, modifies the air gap flux of main magnet, and hence controls sensitivity of movement. The pointer can thus be set at proper full scale marking in compensation against changes in battery emf, without any change in the electrical circuit. The scale calibrations thus do not get disturbed when the magnetic shunt is adjusted.

1. Multi-range Series Ohmmeter

For most practical purposes, it is necessary that a single ohmmeter be used for measurement of a wide range of resistance values. Using a single scale for such measurements will lead to inconvenience in meter readings and associated inaccuracies. Multi-range ohmmeters, as shown schematically in Figure 4.4, can be used for such measurements. The additional shunt resistances R_3, R_4, \dots, R_7 are used to adjust the meter current to correspond to 0 to FSD scale each time the range of the unknown resistance R_x is changed. In a practical multi-range ohmmeter, these shunt resistances are changed by rotating the range setting dial of the ohmmeter. The photograph of such a laboratory grade analog multi-range ohmmeter is provided in Figure 4.5.

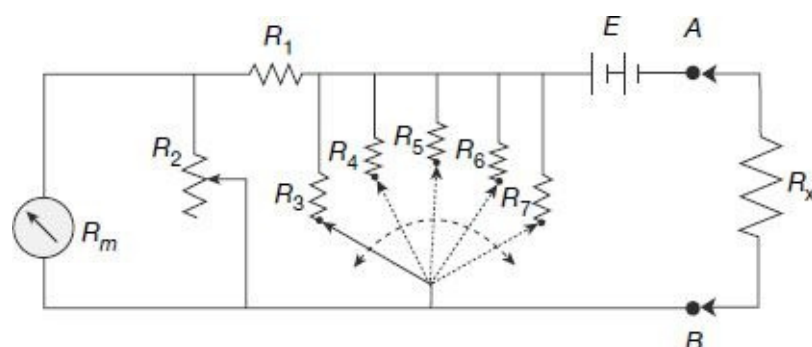

Figure 4.4 Multi-range series-type ohmmeter



Figure 4.5 Photograph of multi-range ohmmeter (Courtesy, SUNWA)

2. Shunt-type Ohmmeter

Figure 4.6 shows the schematic diagram of a simple shunt-type ohmmeter.

The shunt-type ohmmeter consists of a battery in series with an adjustable resistance R_1 and a sensitive dc measuring PMMC ammeter. The unknown resistance R_x to be measured is connected across terminals A–B and parallel with the meter.

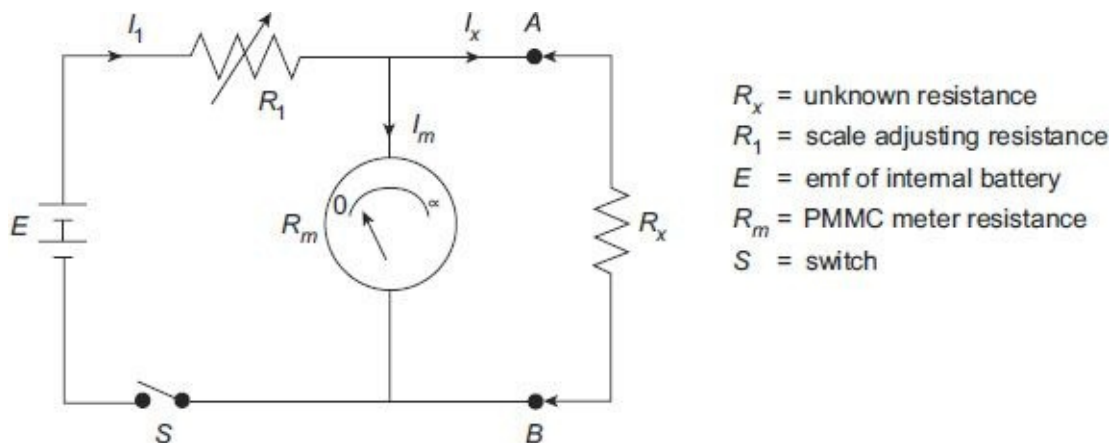

Figure 4.6 Shunt-type ohmmeter

When the terminals A–B are shorted ($R_x = 0$), the meter current is zero, since all the current in the circuit passes through the short circuited path A–B, rather than the meter. This position of the pointer is marked ‘zero-resistance’, i.e., ‘0 Ω’ on the scale. On the other hand, when R_x is removed, i.e., the terminals A–B open circuited ($R_x \rightarrow \infty$), entire current flows through the meter. Selecting proper value of R_1 , this maximum current position of the pointer can be made to read full scale of the meter. This position of the

pointer is marked as ' $\infty\Omega$ ' on the scale. Shunt type ohmmeters, accordingly, has ' $0\ \Omega$ ' at the left most position corresponding to zero current, and ' $\infty\Omega$ ' at the rightmost end of the scale corresponding to FSD current.

When not under measurement, i.e., nothing is connected across the terminals A–B ($R_x \rightarrow \infty$) the battery always drives FSD current through the meter. It is thus essential to disconnect the battery from rest of the circuit when the meter is idle. A switch S, as shown in [Figure 4.6](#), is thus needed to prevent the battery from draining out when the instrument is not in use.

Shape of Scale in Shunt Ohmmeters Internal resistance of the ohmmeter

$$R_i = \frac{R_1 R_m}{R_1 + R_m}$$

With terminals A–B open, the full-scale current through the meter is

$$I_{FSD} = \frac{E}{R_1 + R_m} \quad (4.6)$$

With R_x connected between terminals A–B, the current out of the battery is

$$I_1 = \frac{E}{R_1 + \frac{R_m R_x}{R_m + R_x}}$$

Thus, meter current $I_m = I_1 \times \frac{R_x}{R_x + R_m} = \frac{E}{R_1 + \frac{R_m R_x}{R_m + R_x}} \times \frac{R_x}{R_x + R_m}$ (4.7)

From Eqs (4.6) and (4.7), the meter can be related to the FSD as

$$\frac{I_m}{I_{FSD}} = \frac{\frac{E}{R_1 + \frac{R_m R_x}{R_m + R_x}} \times \frac{R_x}{R_x + R_m}}{\frac{E}{R_1 + R_m}} = \frac{R_x (R_1 + R_m)}{R_1 (R_m + R_x) + R_m R_x} = \frac{R_x (R_1 + R_m)}{R_1 R_m + R_x (R_1 + R_m)}$$

or,
$$\frac{I_m}{I_{FSD}} = \frac{R_x}{\frac{R_1 R_m}{(R_1 + R_m)} + R_x} = \frac{R_x}{R_x + R_i}$$

$$I_m = \frac{R_x}{R_x + R_i} \times I_{FSD} \quad (4.8)$$

From Eq (4.8), it can be observed that the meter current I_m increases almost linearly with the resistance R_x to be measured for smaller values of R_x when $R_x \ll R_i$. The scale (angle of deflection) in shunt type ohmmeters is thus almost linear in the lower range, but progressively becomes more cramped at higher values of R_x . Shunt-type ohmmeters are thus particularly suitable for measurement of low resistances when the meter scale is nearly uniform.

Design a single-range series-type ohmmeter using a PMMC ammeter that has internal resistance of $50\ \Omega$ and requires a current of $1\ \text{mA}$ for full-scale deflection.

Example 4.1

The internal battery has a voltage of 3 V. It is desired to read half scale at a resistance value of 2000 Ω . Calculate (a) the values of shunt resistance and current limiting series resistance, and (b) range of values of the shunt resistance to accommodate battery voltage variation in the range 2.7 to 3.1 V.

Solution Schematic diagram of the series ohmmeter with the given values is shown in the following figure

Given, R_m = meter internal resistance = 50 Ω

I_{FSD} = meter full scale deflection current = 1 mA

R_h = half-scale deflection resistance = 2000 Ω

E = battery voltage = 3 V

(a) With terminals A–B shorted, when $R_x = 0$

Meter carries maximum current, and current flowing out of the battery is given as

$$I_{1MAX} = \frac{E}{R_i},$$

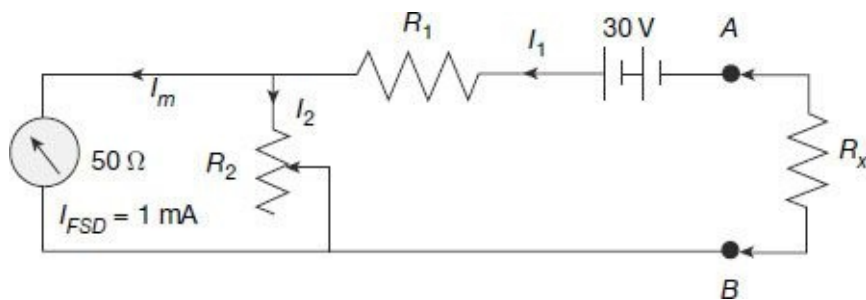

where E = battery voltage = 3 V, and

R_i = internal resistance of the ohmmeter = $R_1 + \frac{R_2 R_m}{R_2 + R_m}$

At half-scale deflection, $R_x = R_h$, and battery current $I_h = \frac{I_{1MAX}}{2} = \frac{E}{R_i + R_h}$

$$\therefore \frac{E}{R_i + R_h} = \frac{E}{2R_i}$$

or, $R_i = R_h$

$$\therefore I_h = \frac{E}{2R_h} = \frac{3}{2 \times 2000} = 0.75 \text{ mA}$$

and $R_h = 2000 = R_i = R_1 + \frac{R_2 R_m}{R_2 + R_m} = R_1 + \frac{50 R_2}{R_2 + 50}$

For full-scale deflection,

$$\therefore \text{ At FSD, } R_2 = \frac{I_{FSD} R_m}{I_2} = \frac{1 \times 10^{-3} \times 50}{0.5 \times 10^{-3}} = 100 \Omega$$

Again, since $R_1 + \frac{50R_2}{R_2 + 50} = 2000$, putting the value of R_2

$$R_1 = 1966.7 \Omega$$

(b) For a battery voltage of $E = 2.7 \text{ V}$, battery current at half scale is

$$I_h = \frac{E}{2R_h} = \frac{2.7}{2 \times 2000} = 0.675 \text{ mA}$$

For full-scale deflection,

$$I_m = I_{FSD} = 1 \text{ mA and } I_1 = 2I_h = 1.35 \text{ mA}$$

Also, $I_m R_m = I_2 R_2$ and $I_1 - I_m = (1.35 - 1) \text{ mA} = 0.35 \text{ mA}$

$$\therefore \text{ At FSD, } R_2 = \frac{I_{FSD} R_m}{I_2} = \frac{1 \times 10^{-3} \times 50}{0.35 \times 10^{-3}} = 142.86 \Omega$$

For a battery voltage of $E = 3.1 \text{ V}$, battery current at half scale is

$$I_h = \frac{E}{2R_h} = \frac{3.1}{2 \times 2000} = 0.775 \text{ mA}$$

For full-scale deflection,

$$I_m = I_{FSD} = 1 \text{ mA and } I_1 = 2I_h = 1.55 \text{ mA}$$

Also, $I_m R_m = I_2 R_2$ and $I_1 - I_m = (1.55 - 1) \text{ mA} = 0.55 \text{ mA}$

$$\therefore \text{ At FSD, } R_2 = \frac{I_{FSD} R_m}{I_2} = \frac{1 \times 10^{-3} \times 50}{0.55 \times 10^{-3}} = 90.0 \Omega$$

\therefore range of R_2 to accommodate the given change in battery voltage is $142.86 \Omega > R_2 > 90.9 \Omega$.

Example 4.2

A shunt-type ohmmeter uses a 2 mA basic d'Arsonval movement with an internal resistance of 25 Ω . The battery emf is 1.5 V.

Calculate (a) value of the resistor in series with the battery to adjust the FSD, and (b) at what point (.percentage) of full-scale will 100 Ω be marked on the scale?

Solution Schematic diagram of a shunt type-ohmmeter under the condition as stated in Example 4.2 is shown below:

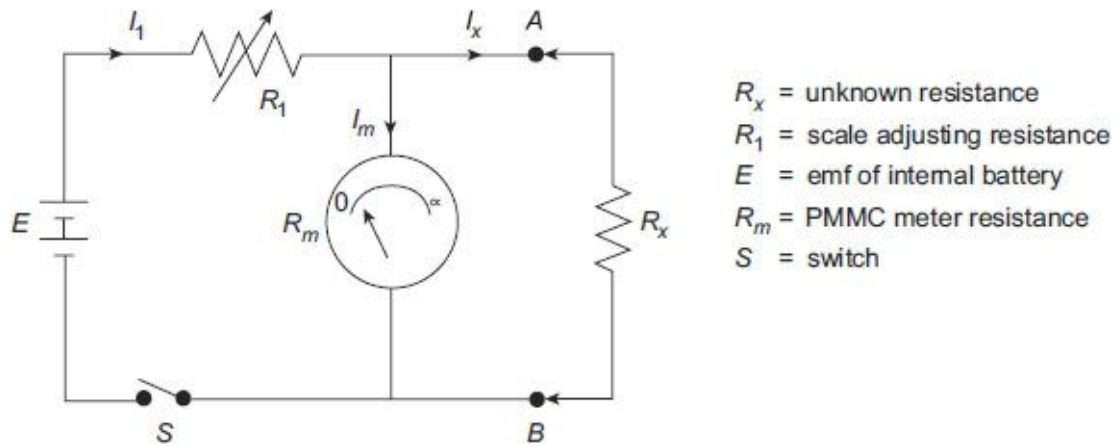

At FSD when terminals A–B is opened, meter FSD current is

$$I_m = I_{FSD} = \frac{E}{R_1 + R_m} = \frac{1.5}{R_1 + 25} = 2 \times 10^{-3}$$

$$\boxed{\text{Thus, } R_1 = 725 \Omega}$$

When $R_x = 100 \Omega$, battery output current will be

$$I_1 = \frac{E}{R_1 + \frac{R_m R_x}{R_m + R_x}} = \frac{1.5}{725 + \frac{25 \times 100}{25 + 100}} = 2.013 \text{ mA}$$

$$\therefore \text{ meter current is } I_m = I_1 \times \frac{R_x}{R_m + R_x} = 2.013 \times \frac{100}{25 + 100} = 1.6104 \text{ mA}$$

Thus, percentage of full scale at which the meter would read 100Ω is

$$\boxed{\frac{I_m}{I_{FSD}} \times 100\% = \frac{1.6104}{2} \times 100\% = 80.52\%}$$

4.2.2 Voltmeter–Ammeter Method for Measuring Resistance

The voltmeter–ammeter method is a direct application of ohm's law in which the unknown resistance is estimated by measurement of current (I) flowing through it and the voltage drop (V) across it. Then measured value of the resistance is

$$R_m = \frac{\text{Voltmeter reading}}{\text{Ammeter reading}} = \frac{V}{I}$$

This method is very simple and popular since the instruments required for measurement are usually easily available in the laboratory.

Two types of connections are employed for voltmeter–ammeter method as shown in [Figure 4.7](#).

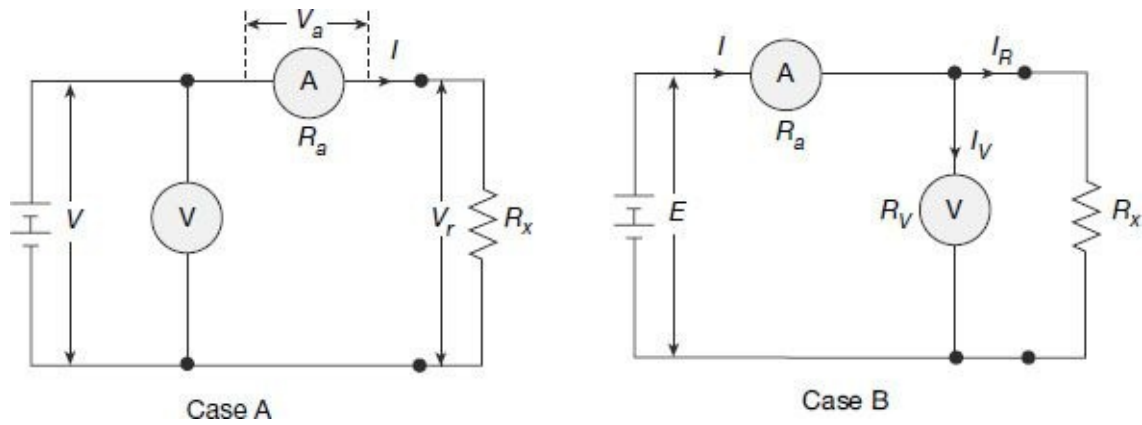

Figure 4.7 Measurement of resistance by voltmeter–ammeter method

R_x = true value of unknown resistance

R_m = measured value of unknown resistance

R_a = internal resistance of ammeter

R_v = internal resistance of voltmeter

It is desired that in both the cases shown in [Figure 4.7](#), the measured resistance R_m would be equal to the true value R_x of the unknown resistance. This is only possible, as we will see, if the ammeter resistance is zero and the voltmeter resistance is infinite.

Case A

In this circuit, the ammeter is connected directly with the unknown resistance, but the voltmeter is connected across the series combination of ammeter and the resistance R_x . The ammeter measures the true value of current through the resistance but the voltmeter does not measure the true value of voltage across the resistance. The voltmeter measures the sum of voltage drops across the ammeter and the unknown resistance R_x .

Let, voltmeter reading = V

And, ammeter reading = I

$$\therefore \text{measured value of resistance} = R_m = \frac{V}{I}$$

However, $V = V_a + V_r$

or, $V = I \times R_a + I \times R_x = I \times (R_a + R_x)$

Thus, $\frac{V}{I} = R_m = (R_a + R_x)$ (4.9)

The measured value R_m of the unknown resistance is thus higher than the true value R_x , by the quantity R_a , internal resistance of the ammeter. It is also clear from the above that true value is equal to the measured value only if the ammeter resistance is zero.

Error in measurement is $\epsilon = \frac{R_m - R_x}{R_x} = \frac{R_a}{R_x}$

Equation (4.10) denotes the fact that error in measurement using connection method

shown in Case A will be negligible only if the ratio $\frac{R_a}{R_x} \rightarrow 0$. In other words, if the resistance under measurement is much higher as compared to the ammeter resistance ($R_x \gg R_a$), then the connection method shown in Case A can be employed without involving much error.

Therefore, circuit shown in Case A should be used for measurement of high resistance values.

Case B

In this circuit, the voltmeter is connected directly across the unknown resistance, but the ammeter is connected in series with the parallel combination of voltmeter and the resistance R_x . The voltmeter thus measures the true value of voltage drop across the resistance but the ammeter does not measure the true value of current through the resistance. The ammeter measures the summation of current flowing through the voltmeter and the unknown resistance R_x .

Let, voltmeter reading = V

And, ammeter reading = I

Thus, $V = I_R \times R_x = I_V \times R_V$

However, $I = I_V + I_R$

∴ measured value of resistance

$$= R_m = \frac{V}{I} = \frac{V}{I_V + I_R} = \frac{V}{\frac{V}{R_V} + \frac{V}{R_x}} = \frac{R_V R_x}{R_V + R_x} = \frac{R_x}{1 + \frac{R_x}{R_V}}$$

or $R_m = \frac{R_x}{1 + \frac{R_x}{R_V}}$ (4.11)

The measured value R_m of the unknown resistance is thus lower than the true value R_x by a quantity related to internal resistance of the voltmeter. It is also clear from Eq. (4.11) that true value is equal to the measured value only if the quantity $\frac{R_x}{R_V} \rightarrow 0$, i.e., if voltmeter resistance is infinite. In other words, if the voltmeter resistance is much higher as compared to the resistance under measurement ($R_V \gg R_x$) then the connection method shown in Case B can be employed without involving much error.

Therefore, circuit shown in Case B should be used for measurement of low resistance values.

A voltmeter of 600 Ω resistance and a milliammeter of 0.8 Ω resistance are used to measure two unknown resistances by voltmeter–ammeter method.

If the voltmeter reads 40 V and milliammeter reads 120 mA in both the cases, calculate the percentage error in the values of measured resistances if (a) in the first case, the

Example 4.3

voltmeter is put across the resistance and the milliammeter connected in series with the supply, and (b) in the second case, the voltmeter is connected in the supply side and milliammeter connected directly in series with the resistance.

Solution The connections are shown in the following figure.

Voltmeter reading $V = 40 \text{ V}$

Ammeter reading $I = 120 \text{ mA}$

\therefore measured resistance from voltmeter and I

ammeter readings is given by

$$= R_m = \frac{V}{I} = \frac{40}{120 \times 10^{-3}} = 333 \Omega$$

The ammeter reads the current flowing I_R through the resistance R_x and also the current I_V through the voltmeter resistance R_V .

Thus, $I = I_V + I_R$

Now, the voltmeter and the resistance R_x being in parallel, the voltmeter reading is given by

$$V = I_R \times R_x = I_V \times R_V$$

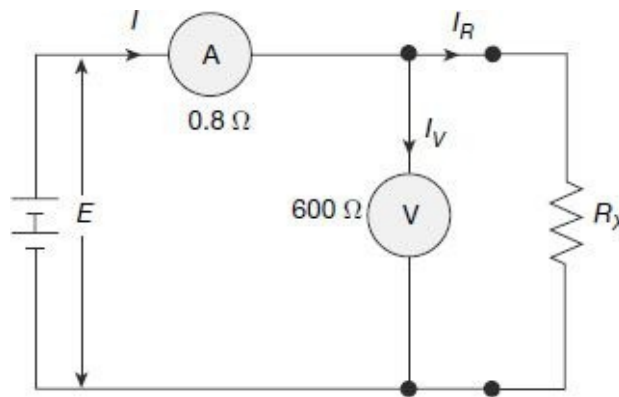

Current through voltmeter

$$I_V = \frac{V}{R_V} = \frac{40}{600} = 66.67 \text{ mA}$$

\therefore true current through resistance $I_R = I - I_V = 120 - 66.67 = 53.33 \text{ mA}$

\therefore true value of resistance $= R_x = \frac{V}{I_R} = \frac{40}{53.33 \times 10^{-3}} = 750 \Omega$

Thus, percentage error $\varepsilon = \frac{R_m - R_x}{R_x} = \frac{333 - 750}{750} \times 100\% = 55.5\%$

The connections are shown in the following figure.

Voltmeter reading $V = 40 \text{ V}$

Ammeter reading $I = 120 \text{ mA}$

∴ measured resistance from voltmeter and ammeter readings is given by

$$= R_m = \frac{V}{I} = \frac{40}{120 \times 10^{-3}} = 333 \Omega$$

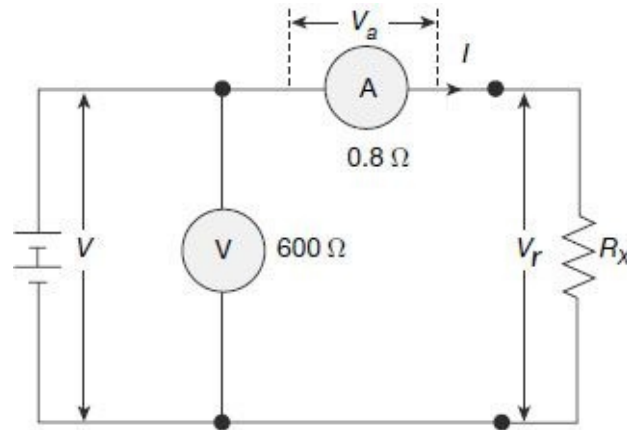

Voltmeter reads the voltage drop V_r across the resistance R_x and also the voltage drop V_a across the ammeter resistance R_a .

Thus, $V = V_a + V_r$

Voltage drop across ammeter

$$V_a = I \times R_a = 120 \times 10^{-3} \times 0.8 = 0.096 \text{ V}$$

∴ true voltage drop across the resistance

$$V_r = V - V_a = 40 - 0.096 \times 39.904 \text{ V}$$

∴ true value of resistance $= R_x = \frac{V_r}{I} = \frac{39.904}{120 \times 10^{-3}} = 332.53 \Omega$

Percentage error in measurement is $\epsilon = \frac{333 - 332.53}{332.53} \times 100\% = 0.14\%$

4.2.3 Substitution Method for Measuring Resistance

The connection diagram for the substitution method is shown in [Figure 4.8](#).

In this method the unknown resistance R_x is measured with respect to the standard variable resistance S . The circuit also contains a steady voltage source V , a regulating resistance r and an ammeter. A switch is there to connect R_x and S in the circuit alternately.

To start with, the switch is connected in position 1, so that the unknown resistance R_x gets included in the circuit. At this condition, the regulating resistance r is adjusted so that the ammeter pointer comes to a specified location on the scale. Next, the switch is thrown to position 2, so that the standard resistance S comes into circuit in place of R_x . Settings in the regulating resistance are not changed. The standard variable resistance S is varied till ammeter pointer reaches the same location on scale as was with R_x . The value of the standard resistance S at this position is noted from its dial. Assuming that the battery emf has not changed and also since the value of r is kept same in both the cases, the current has been kept at the same value while substituting one resistance with another one. The two resistances thus, must be equal. Hence, value of the unknown resistance R_x can be

estimated from dial settings of the standard resistance S .

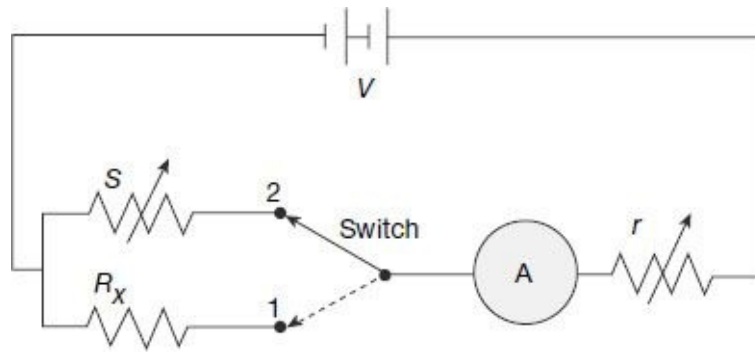

Figure 4.8 Substitution method

Accuracy of this method depends on whether the battery emf remains constant between the two measurements. Also, other resistances in the circuit excepting R and S should also not change during the course of measurement. Readings must be taken fairly quickly so that temperature effects do not change circuit resistances appreciably. Measurement accuracy also depends on sensitivity of the ammeter and also on the accuracy of the standard resistance S .

4.2.4 Wheatstone Bridge for Measuring Resistance

The Wheatstone bridge is the most commonly used circuit for measurement of medium-range resistances. The Wheatstone bridge consists of four resistance arms, together with a battery (voltage source) and a galvanometer (null detector). The circuit is shown in [Figure 4.9](#).

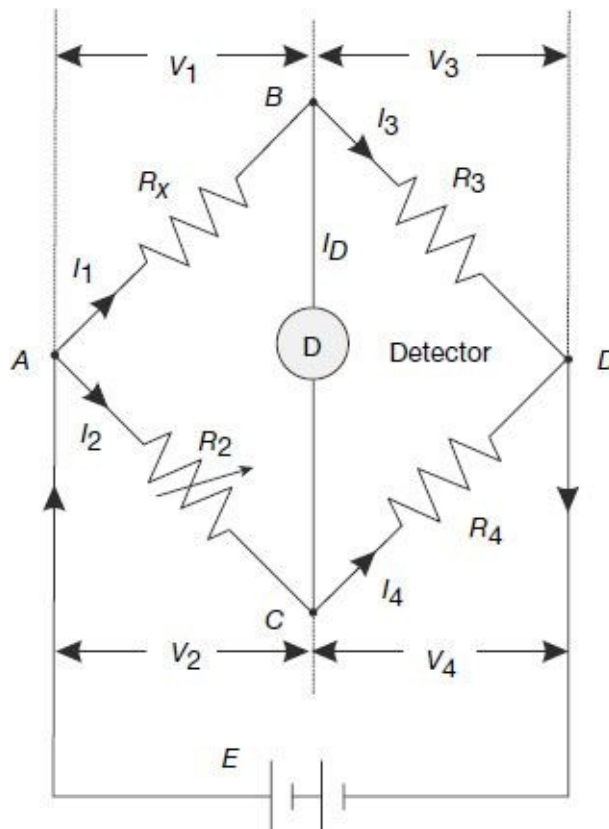

Figure 4.9 Wheatstone bridge for measurement of resistance

In the bridge circuit, R_3 and R_4 are two fixed known resistances, R_2 is a known variable resistance and R_x is the unknown resistance to be measured. Under operating conditions,

current I_D through the galvanometer will depend on the difference in potential between nodes B and C . A bridge balance condition is achieved by varying the resistance R_2 and checking whether the galvanometer pointer is resting at its zero position. At balance, no current flows through the galvanometer. This means that at balance, potentials at nodes B and C are equal. In other words, at balance the following conditions are satisfied:

1. The detector current is zero, i.e., $I_D = 0$ and thus $I_1 = I_3$ and $I_2 = I_4$
2. Potentials at node B and C are same, i.e., $V_B = V_C$, or in other words, voltage drop in the arm AB equals the voltage drop across the arm AC , i.e., $V_{AB} = V_{AC}$ and voltage drop in the arm BD equals the voltage drop across the arm CD , i.e., $V_{BD} = V_{CD}$

From the relation $V_{AB} = V_{AC}$ we have $I_1 \times R_x = I_2 \times R_2$ (4.12)

At balanced 'null' position, since the galvanometer carries no current, it as if acts as if open circuited, thus

$$I_1 = I_3 = \frac{E}{R_x + R_3} \text{ and } I_2 = I_4 = \frac{E}{R_2 + R_4}$$

Thus, from Eq. (4.12), we have

$$\frac{E}{R_x + R_3} \times R_x = \frac{E}{R_2 + R_4} \times R_2$$

or,
$$\frac{R_x + R_3}{R_x} = \frac{R_2 + R_4}{R_2}$$

or,
$$\frac{R_x + R_3}{R_x} - 1 = \frac{R_2 + R_4}{R_2} - 1$$

or,
$$\frac{R_x + R_3 - R_x}{R_x} = \frac{R_2 + R_4 - R_2}{R_2}$$

or,
$$\frac{R_3}{R_x} = \frac{R_4}{R_2}$$

or,
$$\frac{R_x}{R_2} = \frac{R_3}{R_4}$$

or,
$$R_x = R_2 \times \frac{R_3}{R_4} \tag{4.13}$$

Thus, measurement of the unknown resistance is made in terms of three known resistances. The arms BD and CD containing the fixed resistances R_3 and R_4 are called the **ratio arms**. The arm AC containing the known variable resistance R_2 is called the **standard arm**. The range of the resistance value that can be measured by the bridge can be increased simply by increasing the ratio R_3/R_4 .

Errors in a Wheatstone Bridge

A Wheatstone bridge is a fairly convenient and accurate method for measuring resistance. However, it is not free from errors as listed below:

1. Discrepancies between the true and marked values of resistances of the three known arms can introduce errors in measurement.

2. Inaccuracy of the balance point due to insufficient sensitivity of the galvanometer may result in false null points.
3. Bridge resistances may change due to self-heating (I^2R) resulting in error in measurement calculations.
4. Thermal emfs generated in the bridge circuit or in the galvanometer in the connection points may lead to error in measurement.
5. Errors may creep into measurement due to resistances of leads and contacts. This effect is however, negligible unless the unknown resistance is of very low value.
6. There may also be personal errors in finding the proper null point, taking readings, or during calculations.

Errors due to inaccuracies in values of standard resistors and insufficient sensitivity of galvanometer can be eliminated by using good quality resistors and galvanometer.

Temperature dependent change of resistance due to self-heating can be minimised by performing the measurement within as short time as possible.

Thermal emfs in the bridge arms may cause serious trouble, particularly while measuring low resistances. Thermal emf in galvanometer circuit may be serious in some cases, so care must be taken to minimise those effects for precision measurements. Some sensitive galvanometers employ all-copper systems (i.e., copper coils as well as copper suspensions), so that there is no junction of dissimilar metals to produce thermal emf. The effect of thermal emf can be balanced out in practice by adding a reversing switch in the circuit between the battery and the bridge, then making the bridge balance for each polarity and averaging the two results.

Example 4.4

Four arms of a Wheatstone bridge are as follows: $AB = 100 \Omega$, $BC = 10 \Omega$, $CD = 4 \Omega$, $DA = 50 \Omega$. A galvanometer with internal resistance of 20Ω is connected between BD , while a battery of 10-V dc is connected between AC . Find the current through the galvanometer. Find the value of the resistance to be put on the arm DA so that the bridge is balanced.

Solution Configuration of the bridge with the values given in the example is as shown below:

To find out current through the galvanometer, it is required to find out Thevenin equivalent voltage across nodes BD and also the Thevenin equivalent resistance between terminals BD .

To find out Thevenin's equivalent voltage across BD , the galvanometer is open circuited, and the circuit then looks like the figure given below.

At this condition, voltage drop across the arm BC is given by

$$V_{BC} = 10 \times \frac{10}{100+10} = 0.91 \text{ V}$$

Voltage drop across the arm DC is given by:

$$V_{DC} = 10 \times \frac{4}{50+4} = 0.74 \text{ V}$$

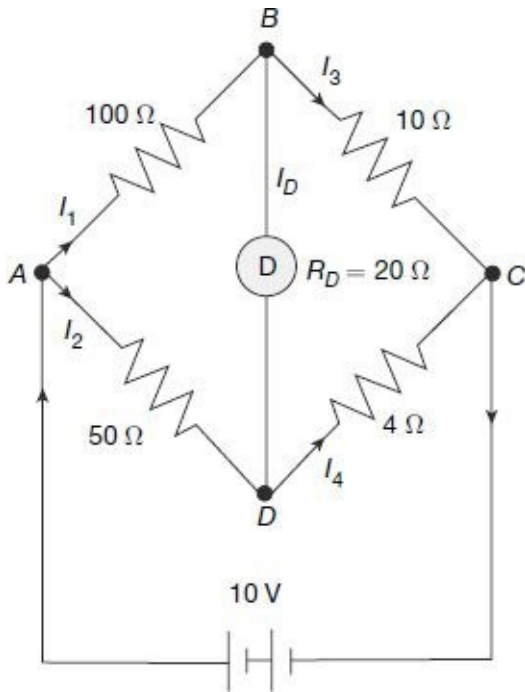

Hence, voltage difference between the nodes B and D , or the Thevenin equivalent voltage between nodes B and D is

$$V_{TH} = V_{BD} = V_B - V_D = V_{BC} - V_{DC} = 0.91 - 0.74 = 0.17 \text{ V}$$

To obtain the Thevenin equivalent resistance between nodes B and D , the 10 V source need to be shorted, and the circuit looks like the figure given below.

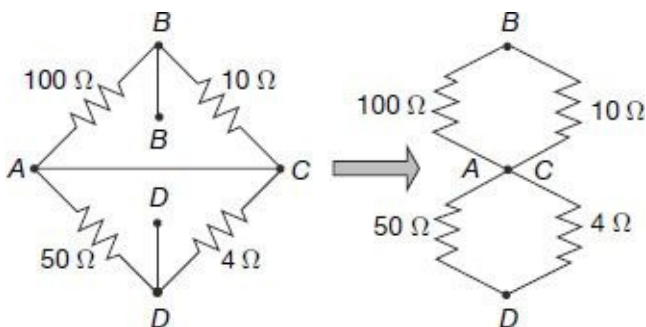

The Thevenin equivalent resistance between the nodes B and D is thus

$$R_{Th} = \frac{100 \times 10}{100+10} + \frac{50 \times 4}{50+4} = 12.79 \Omega$$

Hence, current through galvanometer is

$$I_D = \frac{V_{Th}}{R_D + R_{Th}} = \frac{0.17}{20+12.79} = 5.18 \text{ mA}$$

In order to balance the bridge, there should be no current through the galvanometer, or in other words, nodes B and D must be at the same potential.

Balance equation is thus

$$\frac{100}{10} = \frac{R_{DA}}{4} \quad \text{or, } R_{DA} = 40 \Omega$$

Example 4.5

The four arms of a Wheatstone bridge are as follows: $AB = 100 \Omega$, $BC = 1000 \Omega$, $CD = 4000 \Omega$, $DA = 400 \Omega$. A galvanometer with internal resistance of 100Ω and sensitivity of $10 \text{ mm}/\mu\text{A}$ is connected between AC , while a battery of 4 V dc is connected between BD . Calculate the current through the galvanometer and its deflection if the resistance of arm DA is changed from 400Ω to 401Ω .

Solution Configuration of the bridge with the values given in the example is as shown below:

To find out current through the galvanometer, it is required to find out the Thevenin equivalent voltage across nodes AC and also the Thevenin equivalent resistance between terminals AC .

To find out Thevenin equivalent voltage across AC , the galvanometer is open circuited. At this condition, voltage drop across the arm AB is given by

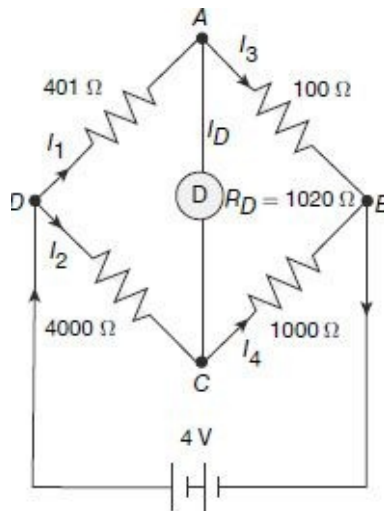

$$V_{AB} = 4 \times \frac{100}{100 + 401} = 0.798 \text{ V}$$

Voltage drop across the arm CB is given by

$$V_{CB} = 4 \times \frac{1000}{4000 + 1000} = 0.8 \text{ V}$$

Hence, voltage difference between the nodes A and C , or the Thevenin equivalent voltage between nodes A and C is

$$V_{TH} = V_{AC} = V_A - V_C = V_{AB} - V_{CB} = 0.798 - 0.8 = -0.002 \text{ V}$$

To obtain the Thevenin equivalent resistance between nodes A and C , the 10 V source need to be shorted. Under this condition, the Thevenin equivalent resistance between the nodes A and C is thus

$$R_{Th} = \frac{100 \times 401}{100 + 401} + \frac{1000 \times 4000}{1000 + 4000} = 880.04 \Omega$$

Hence, current through the galvanometer is

$$I_D = \frac{V_{Th}}{R_D + R_{Th}} = \frac{0.002}{100 + 880.04} = 2.04 \mu\text{A}$$

Deflection of the galvanometer

$$= \text{Sensitivity} \times \text{Current} = 10 \text{ mm}/\mu\text{A} = 2.04 \mu\text{A} = 20.4 \text{ mm}$$

4.3

MEASUREMENT OF LOW RESISTANCES

The methods used for measurement of medium resistances are not suitable for measurement of low resistances. This is due to the fact that resistances of leads and contacts, though small, are appreciable in comparison to the low resistances under measurement. For example, a contact resistance of 0.001Ω causes a negligible error when a medium resistance of value say, 100Ω is being measured, but the same contact resistance would cause an error of 10% while measuring a low resistance of value 0.01Ω . Hence special type of construction and techniques need to be used for measurement of low resistances to avoid errors due to leads and contacts. The different methods used for measurement of low range resistances are (i) voltmeter–ammeter method, (iii) Kelvin’s double-bridge method, and (iv) potentiometer method.

4.3.1 Voltmeter–Ammeter Method for Measuring Low Resistance

In principle, the voltmeter–ammeter method for measurement of low resistance is very similar to the one used for measurement of medium resistances, as described in Section 4.2.2. This method, due to its simplicity, is very commonly used for measurement of low resistances when accuracy of the order of 1% is sufficient. The resistance elements, to be used for such measurements, however, need to be of special construction. Low resistances are constructed with four terminals as shown in [Figure 4.10](#).

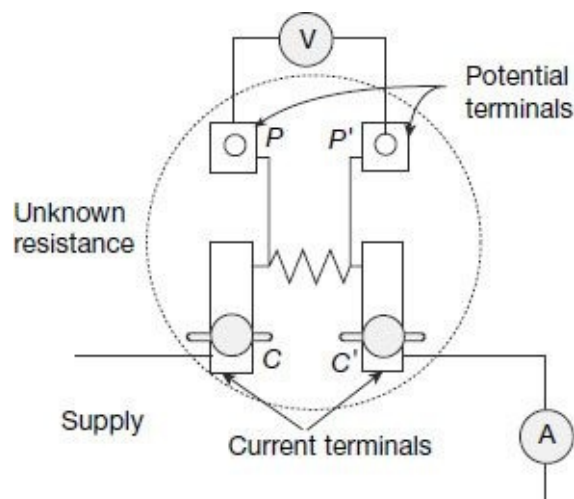

Figure 4.10 Voltmeter–ammeter method for measuring

One pair of terminals CC' , called the current terminals, is used to lead current to and from the resistor. The voltage drop across the resistance is measured between the other pair of terminals PP' , called the potential terminals. The voltage indicated by the voltmeter is thus simply the voltage drop of the resistor across the potential terminals PP' and does not include any contact resistance drop that may be present at the current terminals CC' .

Contact drop at the potential terminals PP' are, however, less itself, since the currents passing through these contacts are extremely small (even zero under ‘null’ balance condition) owing to high resistance involved in the potential circuit. In addition to that, since the potential circuit has a high resistance voltmeter in it, any contact resistance drop in the potential terminals PP' will be negligible with respect to the high resistances involved in the potential circuit.

Value of the unknown resistance R_X in this case is given by

$$R_X = \frac{\text{Voltmeter reading}}{\text{Ammeter reading}}$$

Precise measurement in this method requires that the voltmeter resistance to be appreciably high, otherwise the voltmeter current will be an appreciable fraction of the current actually flowing through the ammeter, and a serious error may be introduced in this account.

4.3.2 Kelvin’s Double-Bridge Method for Measuring Low Resistance

Kelvin’s double-bridge method is one of the best available methods for measurement of low resistances. It is actually a modification of the Wheatstone bridge in which the errors due to contacts and lead resistances can be eliminated. The connections of the bridge are shown in [Figure 4.11](#).

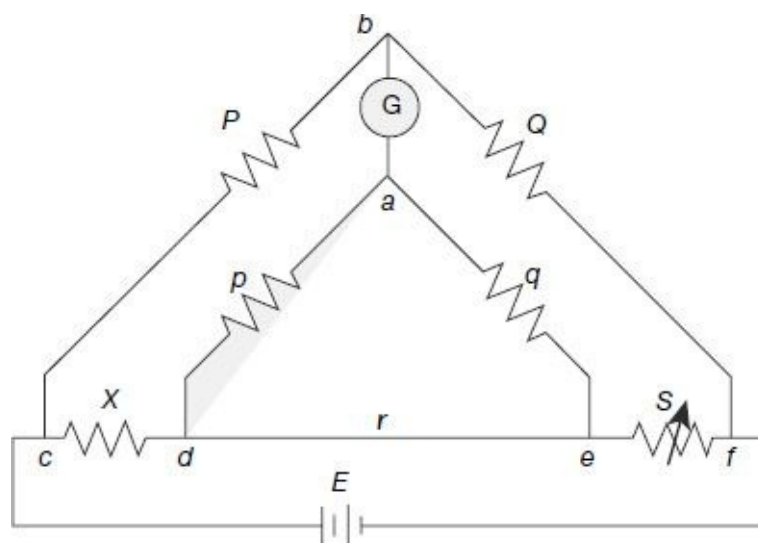

Figure 4.11 Kelvin’s double bridge

Kelvin’s double bridge incorporates the idea of a second set of ratio arms, namely, p and q , and hence the name ‘**double bridge**’.

X is the unknown low resistance to be measured, and S is a known value standard low resistance. ‘ r ’ is a very low resistance connecting lead used connect the unknown resistance X to the standard resistance S . All other resistances $P, Q, p,$ and q are of medium range. Balance in the bridge is achieved by adjusting S .

Under balanced condition, potentials at the nodes a and b must be equal in order that the galvanometer G gives “null” deflection. Since at balance, no current flows through the galvanometer, it can be considered to be open circuited and the circuit can be represented as shown in [Figure 4.12](#).

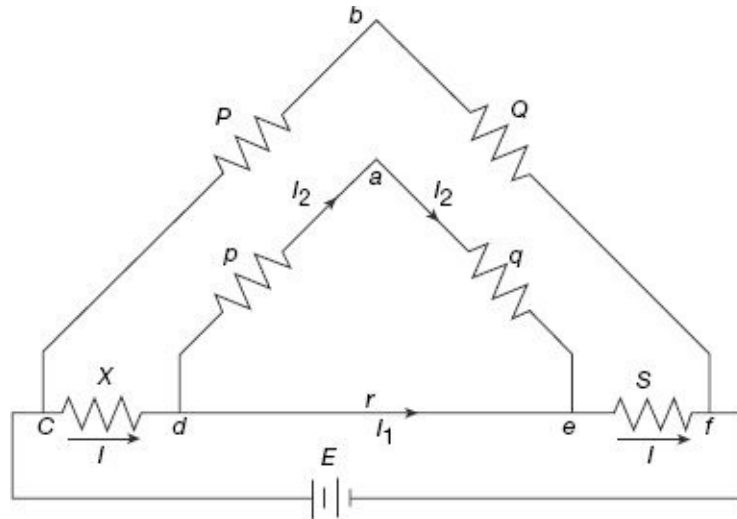

Figure 4.12 Kelvin’s double-bridge under balanced condition

Since under balanced condition, potentials at the nodes a and b are equal, the we must have

$$V_{cb} = V_{cda}$$

Now,
$$V_{cb} = E \times \frac{P}{P+Q} \tag{4.14}$$

and
$$V_{cda} = V_{cd} + V_{da} = X \times I + p \times I_2$$

where,
$$I_2 = I \times \frac{r}{r+p+q}$$

$$\therefore V_{cda} = I \times X + I \times \frac{pr}{r+p+q} = I \left(X + \frac{pr}{r+p+q} \right) \tag{4.15}$$

Supply voltage
$$E = V_{cd} + V_{de} + V_{ef} = I \times X + I \times \frac{(p+q)}{p+q+r} \times r + I \times S$$

or,
$$E = I \left(X + S + \frac{(p+q)}{p+q+r} \times r \right) \tag{4.16}$$

From (4.14) and (4.16), we have

$$V_{cb} = \frac{P}{P+Q} \times I \left(X + S + \frac{(p+q)}{p+q+r} \times r \right) a \tag{4.17}$$

\therefore the balance equation $V_{cb} = V_{cda}$ can now be re-written as

$$\frac{P}{P+Q} \times I \left(X + S + \frac{(p+q)}{p+q+r} \times r \right) = I \left(X + \frac{pr}{r+p+q} \right) a$$

$$\text{or, } \left(X + S + \frac{(p+q)}{p+q+r} \times r \right) = \left(1 + \frac{Q}{P} \right) \times \left(X + \frac{pr}{r+p+q} \right)$$

$$\text{or, } X + S + \frac{(p+q)}{p+q+r} \times r = X + \frac{pr}{r+p+q} + \frac{Q}{P} \times X + \frac{Q}{P} \times \frac{pr}{r+p+q} a$$

$$\text{or, } S + \frac{(p+q)}{p+q+r} \times r = \frac{pr}{r+p+q} + \frac{Q}{P} \times X + \frac{Q}{P} \times \frac{pr}{r+p+q} a$$

$$\text{or, } \frac{Q}{P} \times X = S + \frac{(p+q)}{p+q+r} \times r - \frac{pr}{r+p+q} - \frac{Q}{P} \times \frac{pr}{r+p+q}$$

$$\text{or, } \frac{Q}{P} \times X = S + \frac{pr}{p+q+r} + \frac{qr}{p+q+r} - \frac{pr}{r+p+q} - \frac{Q}{P} \times \frac{pr}{r+p+q}$$

$$\text{or, } \frac{Q}{P} \times X = S + \frac{qr}{p+q+r} - \frac{Q}{P} \times \frac{pr}{r+p+q}$$

$$\text{or, } \frac{Q}{P} \times X = S + \frac{qr}{p+q+r} \left(1 - \frac{Q}{P} \times \frac{p}{q} \right) a$$

$$\text{or, } X = \frac{P}{Q} \times S + \frac{qr}{p+q+r} \left(\frac{P}{Q} - \frac{p}{q} \right) \quad (4.18)$$

The second quantity of the Eq. (4.18), $\frac{qr}{p+q+r} \left(\frac{P}{Q} - \frac{p}{q} \right)$, can be made very small by making the ratio P/Q as close as possible to p/q. In that case, there is no effect of the connecting lead resistance 'r' on the expression for the unknown resistance. Thus, the expression for the unknown resistance X can now be simply written as

$$\text{or, } X = \frac{P}{Q} \times S \quad (4.19)$$

However, in practice, it is never possible to make the ratio p/q exactly equal to P/Q. Thus, there is always a small error.

$\Delta = \left(\frac{P}{Q} - \frac{p}{q} \right)$ and hence, the resistance value becomes

$$\text{or, } X = \frac{P}{Q} \times S + \frac{q}{p+q+r} \times \Delta \times r \quad (4.20)$$

It is thus always better to keep the value of 'r' as small as possible, so that the product $\Delta \times r$ is extremely small and therefore the error part can be neglected, and we can assume, under balanced condition,

$$X = \frac{P}{Q} \times S$$

In order to take into account the effects of thermoelectric emf, two measurements are normally done with the battery connections reversed. The final value of resistance is taken as the average of these two readings.

*A 4-terminal resistor was measured with the help of a Kelvin's double bridge having the following components:
Standard resistor = 98.02 nW, inner ratio arms = 98.022 Ω*

Example 4.6

and 202 W, outer ratio arms = 98.025 Ω and 201.96 W, resistance of the link connecting the standard resistance and the unknown resistance = 600 nW. Calculate the value of the unknown resistance.

Solution From Eq. (4.18), value of the unknown resistance is

$$X = \frac{P}{Q} \times S + \frac{qr}{p+q+r} \left(\frac{P}{Q} - \frac{p}{q} \right)$$

or,

$$X = \frac{98.025}{201.96} \times 98.02 \times 10^{-6} + \frac{202 \times 600 \times 10^{-6}}{98.022 + 202 + 600 \times 10^{-6}} \left(\frac{98.025}{201.96} - \frac{98.022}{202} \right)$$

or,

$$X = 47.62 \mu\Omega$$

4.3.3 Potentiometer Method for Measuring Low Resistance

The circuit for measurement of low value resistance with a potentiometer is shown in Figure 4.13.

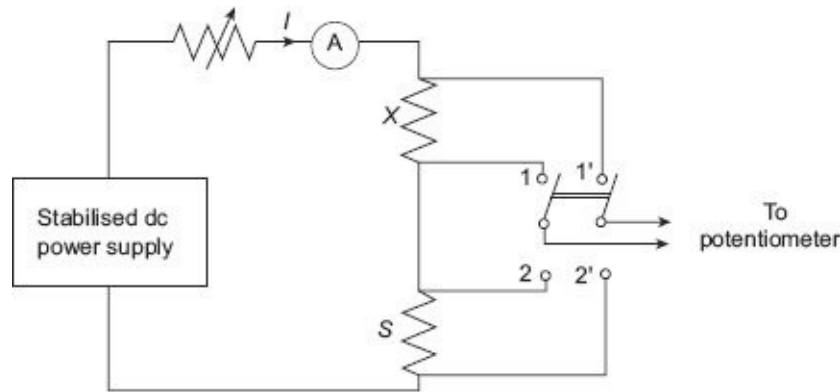

Figure 4.13 Measurement of low resistance using potentiometer

The unknown resistance X is connected in series with a standard known resistance S . Current through the ammeter in the circuit is controlled by a rheostat. A two-pole double throw switch is used. When the switch is in the position 1-1', the unknown resistance X gets connected to the potentiometer, whereas when the switch is at position 2-2', the standard resistance S gets connected to the potentiometer.

Potentiometers are believed to give reasonably accurate values of potentials.

Thus, with the switch in position 1-1', the potentiometer reading is the voltage drop across the unknown resistance, given by

$$V_X = I \times X \tag{4.21}$$

Without changing any of the circuit parameters, now if the switch is thrown to position 2-2', potentiometer now reads the voltage drop across the standard resistance, given by

$$V_S = I \times S \tag{4.22}$$

From Eqs (4.21) and (4.22), we get

$$\text{or, } X = \frac{V_X}{V_S} \times S \tag{4.23}$$

Knowledge of accurate value of the standard resistance S can thus give reasonably accurate values of the unknown resistance X .

Accuracy of this method however, depends on the assumption that the value of current

remains absolutely constant during the two sets of measurements. Therefore, an extremely stabilised dc power supply is required in this method.

Value of the standard resistor S should be of the same order as the unknown resistance X . The ammeter inserted in the circuit has no other function rather than simply indicating whether there is any current is flowing in the circuit is not. Exact value of the current is not required for final calculations. It is however, desired that the current flowing through the circuit be so adjusted that the voltage drop across each resistor is of the order of 1 V to be suitable for accurate measurement by commercially available potentiometers.

4.4

MEASUREMENT OF HIGH RESISTANCES

High resistances of the order of several hundreds and thousands of megohms (MW) are often encountered in electrical equipments in the form of insulation resistance of machines and cables, leakage resistance of capacitors, volume and surface resistivity of different insulation materials and structures.

4.4.1 Difficulties in Measurement of High Resistance

1. Since the resistance under measurement has very high value, very small currents are encountered in the measurement circuit. Adequate precautions and care need to be taken to measure such low value currents.
2. Surface leakage is the main difficulty encountered while measurement of high resistances. The resistivity of the resistance under measurement may be high enough to impede flow of current through it, but due to moisture, dust, etc., the surface of the resistor may provide a lower resistance path for the current to pass between the two measuring electrodes. In other words, there may thus be a leakage through the surface. Leakage paths not only pollute the test results, but also are generally variable from day to day, depending on temperature and humidity conditions. The effect of leakage paths on measurements can be eliminated by the use of guard circuits as described by Figure 4.14.

Figure 4.14(a) shows a high resistance R_X being mounted on a piece of insulation block. A battery along with a voltmeter and a micro-ammeter are used to measure the resistance by voltmeter–ammeter method. The resistance R_X under measurement is fitted on the insulating block at the two binding posts A and B . I_X is the actual current flowing through the high resistance and I_L is the surface leakage current flowing over the body of the insulating block. The micro-ammeter, in this case, thus reads the actual current through the resistor, and also the leakage current ($I = I_X + I_L$). Measured value of the resistance, thus computed from the ratio E/I , will not be the true value of R_X , but will involve some error. To avoid this error, a guard arrangement has been added in Figure 4.14(b). The guard arrangement, at one end is connected to the battery side of the micro-ammeter, and the other end is wrapped over the insulating body and surrounds the resistance terminal A . The surface leakage current now, flows through this guard and bypasses the micro-ammeter. The

micro-ammeter thus reads the true of current I_X through the resistance R_X . This arrangement thus allows correct determination of the resistance value from the readings of voltmeter and micro-ammeter.

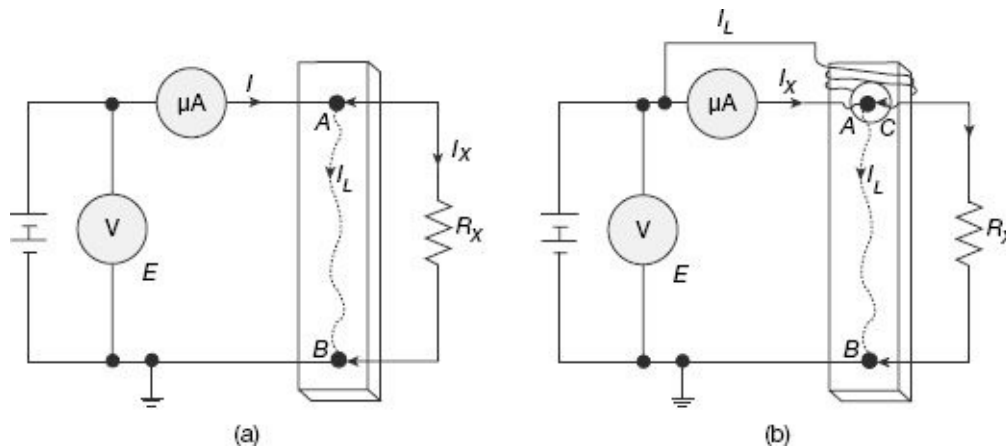

Figure 4.14 Guard circuit for measurement of high resistance: (a) Circuit without guard (b) Circuit with guard

3. Due to electrostatic effects, stray charges may be induced in the measuring circuit. Flow of these stray charges can constitute a current that can be comparable in magnitude with the low value current under measurement in high resistance circuits. This may thus, cause errors in measurement. External alternating electromagnetic fields can also affect the measurement considerably. Therefore, the measuring circuit needs to be carefully screened to protect it against such external electrostatic or electromagnetic effects.
4. While measuring insulation resistance, the test object often has considerable amount of capacitance as well. On switching on the dc power supply, a large charging current may flow initially through the circuit, which gradually decays down. This initial transient current may introduce errors in measurement unless considerable time is provided between application of the voltage supply and reading the measurement, so that the charging current gets sufficient time to die down.
5. High resistance measurement results are also affected by changes in temperature, humidity and applied voltage inaccuracies.
6. Reasonably high voltages are used for measurement of high resistances in order to raise the current to substantial values in order to be measured, which are otherwise extremely low. So, the associated sensitive galvanometers and micro-ammeters need to be adequately protected against such high voltages.

Taking these factors into account, the most well-known methods of high resistance measurements are (i) direct deflection method, (ii) loss of charge method, and (iii) megohmmeter or meggar.

4.4.2 Direct Deflection Method for High Resistance Measurement

The direct deflection method for measuring high resistances is based on the circuit described in Figure 4.14, which in effect is the voltmeter–ammeter method. For measurement of high resistances, a sensitive galvanometer is used instead of a micro-ammeter as shown in Figure 4.14. A schematic diagram for describing the direct deflection

method for measurement of insulation resistance of a metal sheathed cable is given in [Figure 4.15](#).

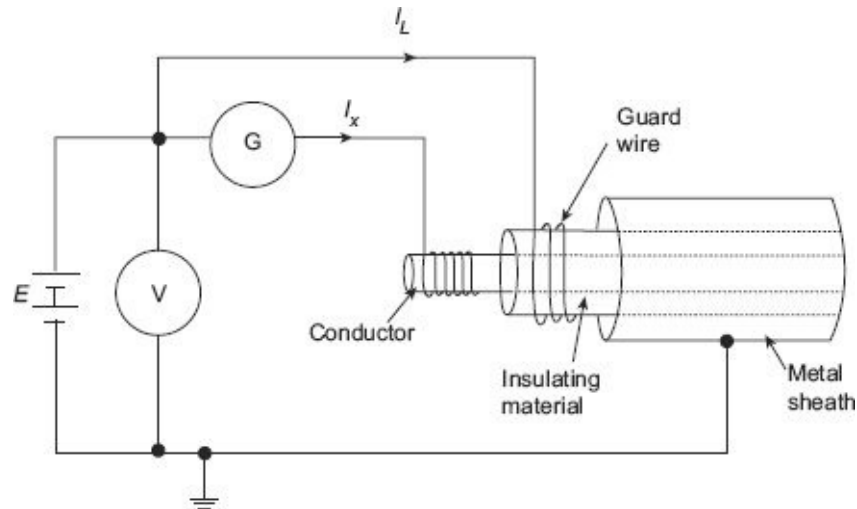

Figure 4.15 Measurement of cable insulation resistance

The test specimen, cable in this case, is connected across a high voltage stable dc source; one end of the source being connected to the inner conductor of the cable, and the other end, to the outer metal sheath of the cable. The galvanometer G , connected in series as shown in [Figure 4.15](#), is intended to measure the current I_x flowing through the volume of the insulation between the central conductor

and the outer metal sheath. Any leakage current I_L flowing over the surface of the insulating material is bypassed through a guard wire wound on the insulation, and therefore does not flow through the galvanometer.

A more detailed scheme for measurement of insulation resistance of a specimen sheet of solid insulation is shown in [Figure 4.16](#).

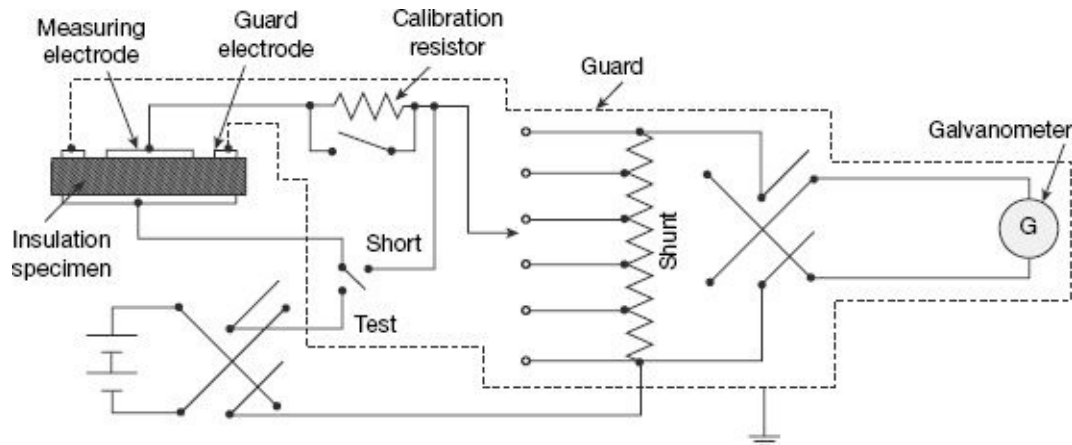

Figure 4.16 Measurement of high resistance by direct deflection method

A metal disk covering almost the entire surface is used as electrode on one side of the insulation sheet under measurement. On the other side of the insulating sheet, the second electrode is made of a smaller size disk. A guard ring is placed around the second electrode with a small spacing in between them. This guarding arrangement bypasses any surface leakage current on the insulator or any other parts of the circuit from entering the actual measuring circuit. The galvanometer thus reads specifically the volume resistance of the insulation specimen, independent of any surface leakage.

A calibrated Ayrton shunt is usually included along with the galvanometer to provide various scale ranges and also to protect it.

The galvanometer scale is graduated directly in terms of resistance. After one set of measurement is over, the galvanometer is calibrated with the help of a high value ($\approx 1 \text{ M}\Omega$) calibrating resistor and the shunts.

In case the insulation under measurement has high inherent capacitance values (like in a cable), there will be an initial inrush of high capacitive charging current when the dc source is first switched on. This charging current will, however, decay down to a steady dc value with time. To protect the galvanometer from such initial rush of high current, the Ayrton shunt connected across the galvanometer should be placed at the highest resistance position (lower most point in [Figure 4.16](#)). Thus, initially the galvanometer is bypassed from the high charging current.

After the test is complete, it is required that the test specimen should be discharged, especially if it is of capacitive in nature. The ‘test-short’ switch is placed in the ‘short’ position so that any charge remaining in the insulation specimen is discharged through the short circuited path.

The change-over switch across the battery enables tests at different polarities. The switch across the galvanometer enables reversal of the galvanometer connections.

A special technique, Price’s guard-wire method is employed for measurement of insulation resistance of cables which do not have metal sheath outside. The schematic diagram of such a measurement system is provided in [Figure 4.17](#).

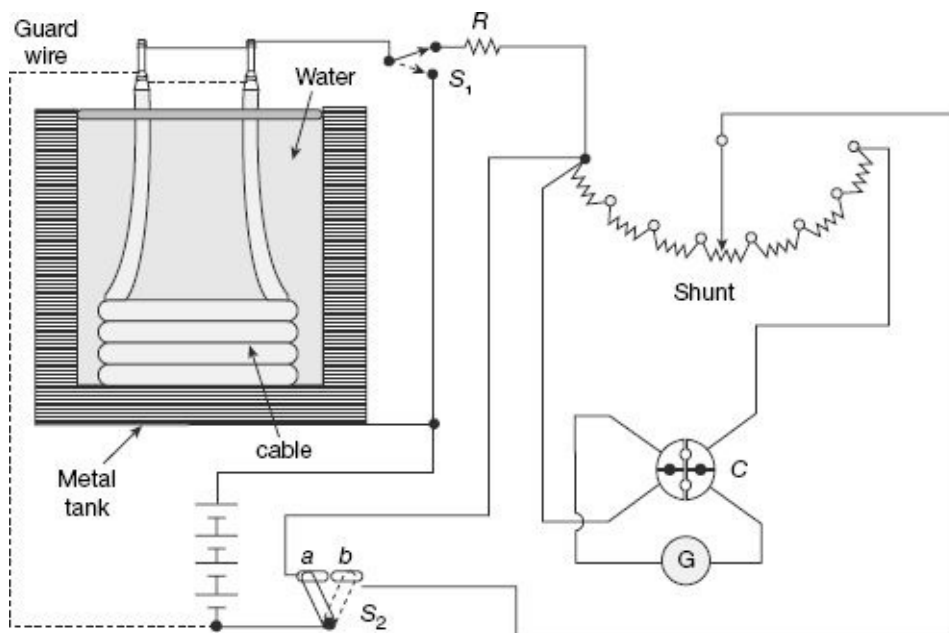

Figure 4.17 Measurement of high resistance by Price’s guard-wire method

The unsheathed cable, except at the two ends where connections are made, is immersed in water in a tank. For testing of the cable insulation, the cable core conductor acts as one electrode and in the absence of the metal sheath outside, the water and the tank act as the other electrode for measurement. The cable is immersed in slightly saline water for about a day and at nearly constant ambient temperature.

The two ends of the cables are trimmed as shown in [Figure 4.17](#), thus exposing the core

conductor as well as some portion of the insulation. The core conductors are connected together to form one electrode of the measuring system. A guard circuit is formed by twisting a bare wire around the exposed portion of the insulation at the two stripped ends of the cable. This guard wire is connected to the negative terminal of the supply battery. The positive terminal of the battery is connected to the metal tank. This enables any surface leakage current to bypass the galvanometer and pass directly to the battery. Thus, the galvanometer will read only true value of the current flowing through volume of the insulation, and not the additional surface leakage current.

The D'Arsonval galvanometer to be used is normally of very high resistance and very sensitive to record the normally extremely low insulation currents. An Ayrton universal shunt is usually included along with the galvanometer to provide various scale ranges and also to protect it. The galvanometer scale is graduated directly in terms of resistance. After one set of measurement is over, the galvanometer is calibrated with the help of the high value ($\approx 1 \text{ M}\Omega$) calibrating resistor R and the shunt. The resistance R and the shunt also serve the purpose of protecting the galvanometer from accidental short circuit current surges. The 4-terminal commutator C , as shown in [Figure 4.17](#) is used for reversal of galvanometer connections.

Since the cable will invariably have high capacitance value, there will be an initial inrush of high capacitive charging current when the dc source is first switched on. This charging current will, however, decay down to a steady dc value with time. To protect the galvanometer from such initial rush of high current, the switch S_2 is placed on position a so that initially the galvanometer is bypassed from the high charging current. Once the capacitor charging period is over and the current settles down, the switch S_2 is pushed over to position b to bring the galvanometer back in the measurement circuit. The contacts a and b are sufficiently close enough to prevent the circuit from breaking while the switch S_2 is moved over.

After the test is complete, it is required that the test specimen should be discharged. The switch S_1 is used for this purpose, so that any charge remaining in the insulation specimen is discharged through itself.

4.4.3 Loss of Charge Method for High Resistance Measurement

In this method, the resistance to be measured is connected directly across a dc voltage source in parallel with a capacitor. The capacitor is charged up to a certain voltage and then discharged through the resistance to be measured. The terminal voltage across the resistance-capacitance parallel combination is recorded for a pre-defined period of time with a help of a high-resistance voltmeter (electrostatic voltmeter or digital electrometers). Value of the unknown resistance is calculated from the discharge time constant of the circuit. Operation of the loss of charge method can be described by the schematic circuit diagram of [Figure 4.18](#).

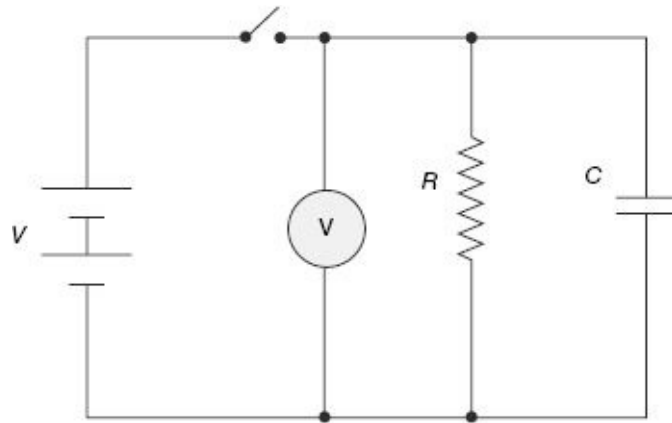

Figure 4.18 Loss of charge method for measurement of high resistance

In [Figure 4.18](#), the unknown resistance R to be measured is connected across the capacitor C and their parallel combination is connected to the dc voltage source.

Let the capacitor is initially charged up to a voltage of V while the switch is kept ON. Once the switch is turned OFF, the capacitor starts to discharge through the resistance R .

During the discharge process, the voltage v across the capacitor at any instant of time t is given by

Thus, the insulation resistance can be calculated as

$$R = \frac{t}{C \times \log_e \left(\frac{V}{v} \right)} \quad (4.24)$$

With known value of C and recorded values of t , V and v , the unknown resistance R can be estimated using (4.24).

The pattern of variation of voltage v with time is shown in [Figure 4.19](#).

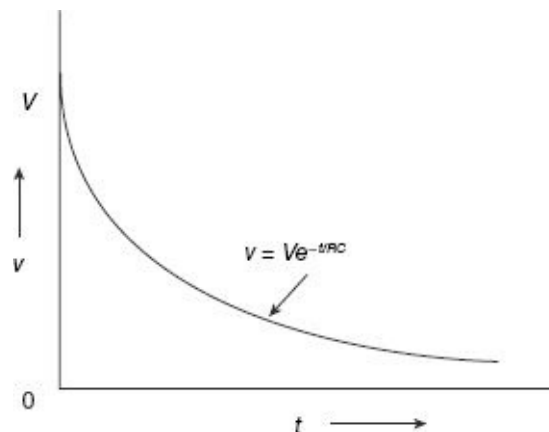

Figure 4.19 Capacitor discharge pattern

Great care must be taken to record the voltages V and v and also the time t very precisely, otherwise large errors may creep in to the calculation results.

This method, though simple in principle, require careful choice of the capacitor. The capacitor C itself must have sufficiently high value of its own leakage resistance, at least in the same range as the unknown resistance under measurement. The resistance of the voltmeter also needs to be very high to have more accurate results.

4.4.4 Megohmmeter, or Meggar, for High Resistance

Measurement

One of the most popular portable type insulation resistance measuring instruments is the megohmmeter or in short, meggar. The meggar is used very commonly for measurement of insulation resistance of electrical machines, insulators, bushings, etc. Internal diagram of a meggar is shown in [Figure 4.20](#).

The traditional analog deflecting-type meggar is essentially a permanent magnet crossed-coil shunt type ohmmeter.

The instrument has a small permanent magnet dc generator developing 500 V dc (some other models also have 100 V, 250 V, 1000 or 2500 V generators). The generator is hand driven, through gear arrangements, and through a centrifugally controlled clutch switch which slips at a predefined speed so that a constant voltage can be developed. Some meggars also have rectified ac as power supply.

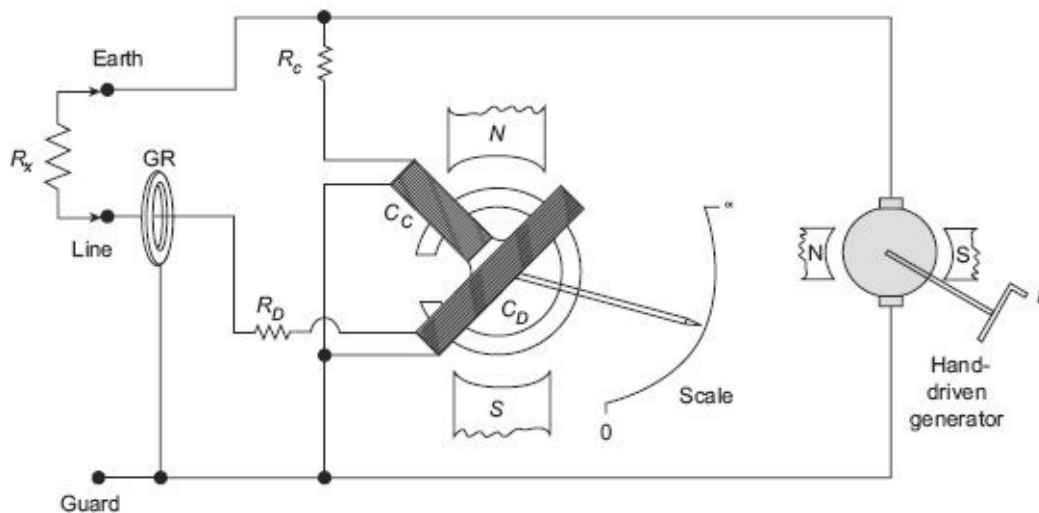

Figure 4.20 Meggar for high resistance measurement

The moving system in such instruments consists of two coils, the control coil C_C and the deflecting coil C_D . Both the coils are mounted rigidly on a shaft that carries the pointer as well. The two coils move in the air gap of a permanent magnet. The two coils are arranged with such numbers of turns, radii of action, and connected across the generator with such polarities that, for external magnetic fields of uniform intensity, the torque produced by the individual coils are in opposition thus giving an astatic combination. The deflecting coil is connected in series with the unknown resistance R_X under measurement, a fixed resistor R_D and then the generator. The current coil or the compensating coil, along with the fixed resistance R_C is connected directly across the generator. For any value of the unknown, the coils and the pointer take up a final steady position such that the torques of the two coils are equal and balanced against each other. For example, when the resistance R_X under measurement is removed, i.e., the test terminals are open-circuited, no current flows through the deflecting coil C_D , but maximum current will flow through the control coil C_C . The control coil C_C thus sets itself perpendicular to the magnetic axis with the pointer indicating ' $\infty \Omega$ ' as marked in the scale shown in [Figure 4.20](#). As the value of R_X is brought down from open circuit condition, more and more current flows through the

deflecting coil CD , and the pointer moves away from the ' $\infty \Omega$ ' mark clockwise (according to Figure 4.20) on the scale, and ultimately reaches the ' 0Ω ' mark when the two test terminals are short circuited.

The surface leakage problem is taken care of by the guard-wire arrangement. The guard ring (GR in Figure 4.20) and the guard wire diverts the surface leakage current from reaching the main moving system and interfering with its performance.

Photographs of some commercially available meggers are shown in Figure 4.21.



(a)



(b)

Figure 4.21 Commercial meggers: (a) Analog type (Courtesy, WACO) (b) Digital type (Courtesy, Yokogawa)

Example 4.7

A cable is tested for insulation resistance by loss of charge method. An electrostatic voltmeter is connected between the cable conductor and earth. This combination is found to form a capacitance of 800 pF between the conductor and earth. It is observed that after charging the cable with 500 V or sufficiently long time, when the voltage supply is withdrawn, the voltage drops down to 160 V in 1 minute . Calculate the insulation resistance of the cable.

Solution The arrangement can be schematically shown by the following figure.

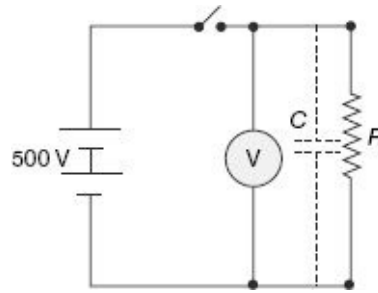

While the cable is charged with 500 V for a long period of time, it is expected that the capacitance of the system is charged up to a steady voltage of 500 V before it is discharged.

Thus, the capacitor discharges from 500 V to 160 V in 1 minute.

During the discharge process, the voltage v across the capacitor at any instant of time t is given by

$$v = Ve^{-t/RC}$$

where V is the initial voltage in the capacitor C , connected across the unknown resistance R .

Thus, the insulation resistance is

$$R = \frac{t}{C \times \log_e \left(\frac{V}{v} \right)} = \frac{60}{800 \times 10^{-12} \times \log_e \left(\frac{500}{160} \right)} = 65 \times 10^9 \Omega = 65,000 \text{ M}\Omega$$

4.5

LOCALISATION OF CABLE FAULTS

Underground cables during their operation can experience various fault conditions. Whereas routine standard tests are there to identify and locate faults in high-voltage cables, special procedures, as will be described in this section are required for localisation of cable faults in low distribution voltage level cables. Determination of exact location of fault sections in underground distribution cables is extremely important from the point of view of quick restoration of service without loss of time for repair.

The faults that are most likely to occur are *ground faults* where cable insulation may break down causing a current to flow from the core of the cable to the outer metal sheath or to the earth; or there may be *short-circuit faults* where a insulation failure between two cables, or between two cores of a multi-core cable results in flow of current between them.

Loop tests are popularly used in localisation of the aforesaid types of faults in low voltage cables. These tests can be carried out to localise a ground fault or a short-circuit fault, provided that an unfaulty cable runs along with the faulty cable. Such tests have the advantage that fault resistance does not affect the measurement sensitivity, that the fault resistance is not too high. Loop tests work on the simple principles of a Wheatstone bridge for measurement of unknown resistances.

4.5.1 Murray Loop Test

Connections for this test are shown in [Figure 4.22](#). [Figure 4.22\(a\)](#) shows the connection

diagram for localisation of ground faults and Figure 4.22(b) relates to localisation of short circuit faults. The general configuration of a Wheatstone bridge is given in Figure 4.23 for ready reference.

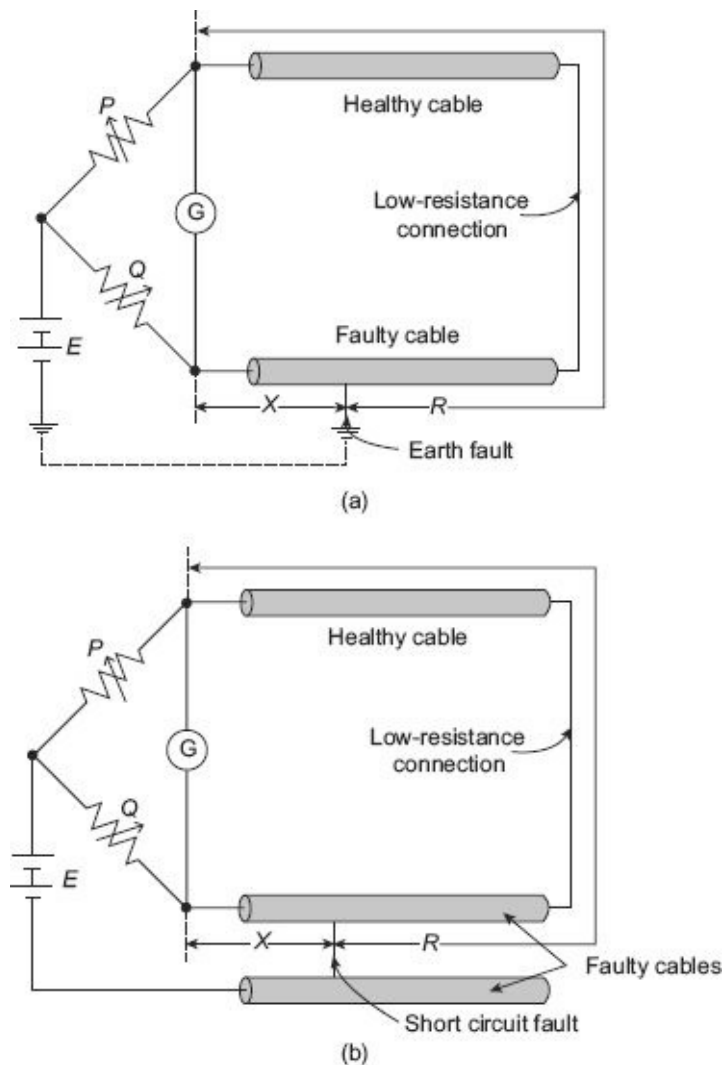

Figure 4.22 Murray loop test for (a) earth fault, and (b) short-circuit fault localisation in cables

The loop circuits formed by the cable conductors form a Wheatstone bridge circuit with the two externally controllable resistors P and Q and the cable resistance X and R as shown in Figure 4.22. The galvanometer G is used for balance detection. The bridge is balanced by adjustment of P and Q till the galvanometer indicates zero deflection.

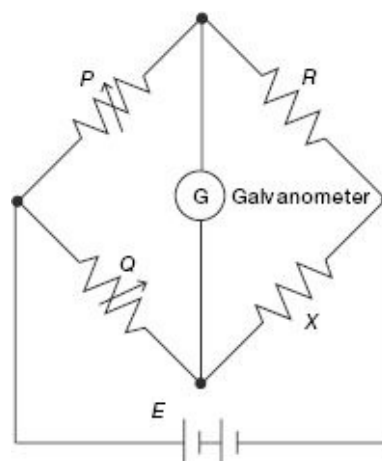

Figure 4.23 Wheatstone bridge configuration relating to Figure 4.22

Under balanced condition,

$$\frac{X}{R} = \frac{Q}{P}$$

or,

$$\frac{X}{R+X} = \frac{Q}{Q+P}$$

$$X = \frac{Q}{Q+P} \times (R+X) \quad (4.25)$$

Here, $(R + X)$ is the total loop resistance formed by the good cable and the faulty cable. When the cables have the same cross section and same resistivity, their resistances are proportional to their lengths.

If L_X represents the distance of the fault point from the test end, and L is the total length of each cable under test, then we can write

1. The resistance X is proportional to the length L_X
2. The resistance $(R + X)$ is proportional to the total length $2L$

Equation (4.25) can now be expressed in terms of the lengths as

Thus, position of the fault can easily be located when the total length of the cables are known.

$$L_X = \frac{Q}{P+X} \times 2L \quad (4.26)$$

4.5.2 Varley Loop Test

In this test, the total loop resistance involving the cables is determined experimentally to estimate the fault location, rather than relying upon the information of length of cables and their resistances per unit length. Connections diagrams for Varley loop test to detect ground fault location and short-circuit fault location in low voltage cables is shown in [Figure 4.24 \(a\)](#) and [Figure 4.24 \(b\)](#) respectively.

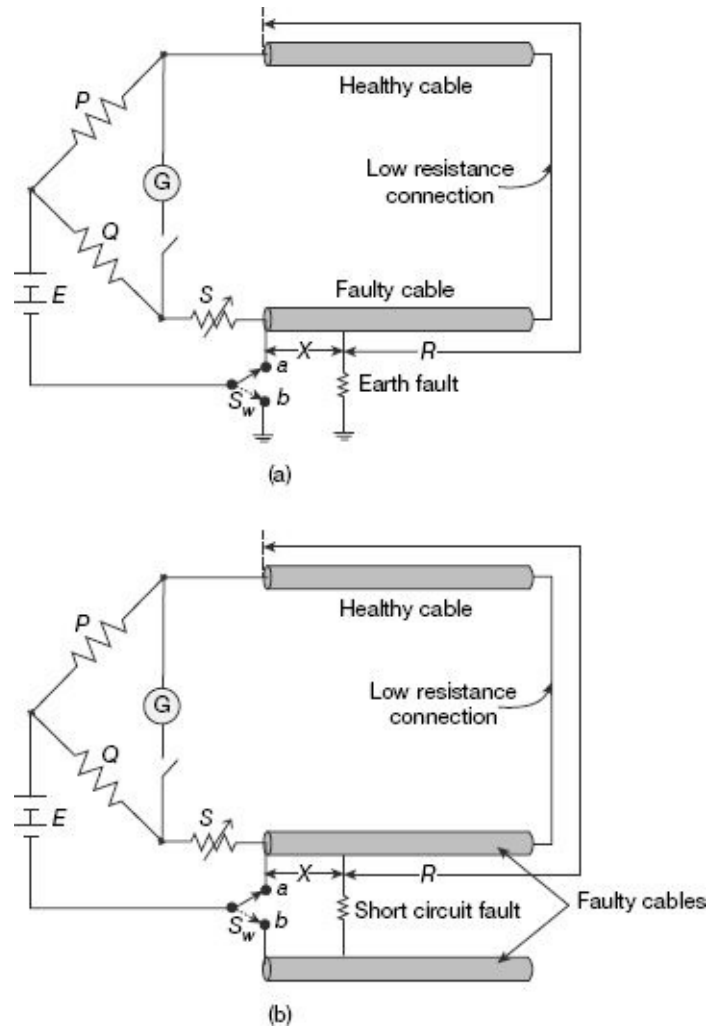

Figure 4.24 Varley loop test for (a) earth fault, and (b) short-circuit fault localisation in cables

The single pole double throw switch S_w is first connected to terminal 'a' and the resistance S is varied to obtain bridge balance.

Let, at this condition, the value of resistance $S = S_1$ when the bridge is balanced. Thus, from Wheatstone bridge principles, at balance condition with the switch at position a , we can write

$$\frac{(R+X)}{S_1} = \frac{P}{Q}$$

or,
$$(R+X) = \frac{P}{Q} \times S_1 \tag{4.27}$$

The total loop resistance $(R + X)$ can thus be experimentally determined using (4.27) by reading the values of P , Q and S_1 under bridge balanced condition with the switch at position a .

Now, the switch S_w is changed over to terminal b and the bridge is balanced again by varying S . Let, at this condition, the value of resistance $S = S_2$ when the bridge is balanced. Thus, once again, from Wheatstone bridge principles, at balance condition with the switch at position b , we can write

$$\frac{R}{X+S_2} = \frac{P}{Q}$$

$$\frac{R+X+S_2}{X+S_2} = \frac{P+Q}{Q}$$

or,

$$X = \frac{(R+X)Q - S_2P}{P+Q} \quad (4.28)$$

Thus, X can be calculated from (4.28) from known values of P , Q , and S_2 and the value of total loop resistance $(R + X)$ obtained from (4.27).

If L_X represents the distance of the fault point from the test end, and L is the total length of each cable under test, then we can write:

1. the resistance X is proportional to the length L_X
2. the resistance $(R + X)$ is proportional to the total length $2L$. Then we can write

$$\frac{X}{R+X} = \frac{L_X}{2L}$$

$$L_X = \frac{X}{R+X} \times 2L \quad (4.29)$$

Thus, the position of the fault can easily be located when the total length of the cables are known.

Both Murray and Varley loop tests are valid only when the cable cross sections are uniform throughout the loop and also between the healthy and faulty cables. Correction factors need also to be included to take care of temperature variation effects. Too many cable joints within length of the cables may also introduce errors in measurement.

In a test for fault to earth by Murray loop test, the faulty cable has a length of 5.2 km.

The faulty cable is looped with a sound (healthy) cable of the same length and cross section. Resistances of the ratio arm of the measuring bridge circuit are 100 Ω and 41.2 Ω at balance. Calculate the distance of the fault point from the testing terminal.

Example 4.8

Solution If X is the resistance of the cable from test end to the fault point, R is the resistance of cable loop from the fault point back over to the other end of the test point, and P and Q are the resistance of the ratio arm, then we can write

$$X = \frac{Q}{Q+P} \times (R+X)$$

If L_X be the distance of the fault point from the test end and L be the length of each cable. If resistivity of the cable core material r is and each of them has cross-sectional area A , then we can write

$$\therefore X = \rho \frac{L_X}{A} \text{ and } (R+X) = \rho \frac{2L}{A}$$

$$\therefore \rho \frac{L_X}{A} = \frac{Q}{P+Q} \times \rho \frac{2L}{A}$$

$$\text{or, } L_X = \frac{Q}{P+Q} \times 2L$$

$$\text{or, } L_X = \frac{41.2}{41.2+100} \times 2 \times 5.2$$

$$\text{or, } L_X = 3.03 \text{ km}$$

Thus, the fault has occurred at a distance of 3.03 km from the test end.

Example 4.9

Varley Loop test is being used to locate short circuit fault. The faulty and sound cables are identical with resistances of 0.5 Ω per km. The ratio arms are set at 15 Ω and 40 Ω. Values of the variable resistance connected with the faulty cable are 20 Ω and 10 Ω at the two positions of the selector switch. Determine the length of each cable and fault distance from test end.

Solution Let S_1 be the resistance of the variable resistance at loop resistance measuring position of the selector switch and S_2 be the resistance of the variable resistor at fault location measuring position of the selector switch.

Hence, at the first position of the switch we can write:

$$\frac{(R+X)}{S_1} = \frac{P}{Q}$$

where X is the resistance of the cable from test end to the fault point, R is the resistance of cable loop from the fault point back over to the other end of the test point, and P and Q are the resistance of the ratio arm

Thus, total resistance of the loop is given as

$$(R+X) = \frac{P}{Q} \times S_1 = \frac{15}{40} \times 20 = 7.5 \Omega$$

Thus, resistance of each cable = $7.5/2 = 3.75 \Omega$

length of each cable = $3.75/0.5 = 7.5 \text{ km}$

At the second position of the switch, we have

$$\frac{R}{X+S_2} = \frac{P}{Q}$$

$$\text{or, } \frac{R+X+S_2}{X+S_2} = \frac{P+Q}{Q}$$

$$\text{or, } X = \frac{(R+X)Q - S_2P}{P+Q} = \frac{7.5 \times 40 - 10 \times 15}{15+40} = 2.73 \Omega$$

. distance of the fault point from test end = $2.73/0.5 = 5.45 \text{ km}$

EXERCISE

Objective-type Questions

- In a series-type ohmmeter
 - zero marking is on the left-hand side
 - zero marking is at the centre
 - zero marking is on the right-hand side
 - zero marking may be either on left or right-hand side
- In series type ohmmeters, zero adjustment should be done by
 - changing the shunt resistance across the meter movement
 - changing the series resistance
 - changing the series and the shunt resistance
 - changing the battery voltage
- Screw adjustments are preferred over shunt resistance adjustments for zero calibration in ohmmeters because
 - the former method is less costly
 - the former method does not disturb the scale calibration
 - the former method does not disturb the meter magnetic field
 - all of the above
- The shape of scale in an analog series-type ohmmeter is
 - linearly spaced (b) cramped near the start
 - cramped near the end (d) directly proportional to the resistance
- Shunt-type ohmmeters have on their scale
 - zero ohm marking on the right corresponding to zero current
 - zero ohm marking on the right corresponding to full scale current
 - infinite ohm marking on the right corresponding to zero current
 - infinite ohm marking on the right corresponding to full scale current
- Shunt-type ohmmeters have a switch along with the battery to
 - disconnect the battery when not in use
 - prevent meter from getting damaged when measuring very low resistances
 - compensate for thermo-emf effects by reversing battery polarity
 - all of the above
- The shape of scale in an analog shunt-type ohmmeter is
 - linearly spaced at lower scales (b) cramped near the start
 - linearly spaced at higher scales (d) uniform all throughout the scale
- High resistances using the voltmeter–ammeter method should be measured with
 - voltmeter connected to the source side
 - ammeter connected to the source side
 - any of the two connections
 - readings are to be taken by interchanging ammeter and voltmeter positions
- Low resistances using the voltmeter–ammeter method should be measured with
 - voltmeter connected to the source side
 - ammeter connected to the source side
 - any of the two connections

- (d) readings are to be taken by interchanging ammeter and voltmeter positions
10. Accuracy of the substitution method for measurement of unknown resistance depends on
- (a) accuracy of the ammeter
 - (b) accuracy of the standard resistance to which the unknown is compared
 - (c) accuracy in taking the readings
 - (d) all of the above
11. The null detector used in a Wheatstone bridge is basically a
- (a) sensitive voltmeter (b) sensitive ammeter
 - (c) may be any of the above (d) none of (a) or (b)
12. Wheatstone bridge is not preferred for precision measurements because of errors due to
- (a) resistance of connecting leads (b) resistance of contacts
 - (c) thermo-electric emf (d) all of the above
13. Error due to thermo-electric emf effects in a Wheatstone bridge can be eliminated by
- (a) taking the readings as quickly as possible
 - (b) by avoiding junctions with dissimilar metals
 - (c) by using a reversing switch to change battery polarity
 - (d) all of the above
14. Low resistances are measured with four terminals to
- (a) eliminate effects of leads
 - (b) enable the resistance value to be independent of the nature of contact at the current terminals
 - (c) to facilitate connections to current and potential coils of the meters
 - (d) all of the above
15. Kelvin's double bridge is called 'double' because
- (a) it has double the accuracy of a Wheatstone bridge
 - (b) its maximum scale range is double that of a Wheatstone bridge
 - (c) it can measure two unknown resistances simultaneously, i.e., double the capacity of a Wheatstone bridge
 - (d) it has two additional ratio arms, i.e., double the number of ratio arms as compared to a Wheatstone bridge
16. Two sets of readings are taken in a Kelvin's double bridge with the battery polarity reversed in order to
- (a) eliminate the error due to contact resistance
 - (b) eliminate the error due to thermo-electric effect
 - (c) eliminate the error due to change in battery voltage
 - (d) all of the above
17. Potentiometers, when used for measurement of unknown resistances, give more accurate results as compared to the voltmeter-ammeter method because
- (a) there is no error due to thermo-electric effect in potentiometers
 - (b) the accuracy of voltage measurement is higher in potentiometers
 - (c) personnel errors while reading a potentiometer is comparatively less
 - (d) all of the above
18. 'Null detection method' is more accurate than 'deflection method' for measurement of unknown resistances because
- (a) the former does not include errors due to nonlinear scale of the meters
 - (b) the former does not include errors due to change in battery voltage

- (c) the former does to depend on meter sensitivity at balanced condition
 (d) all of the above
19. Guard terminals are recommended for high resistance measurements to
- bypass the leakage current
 - guard the resistance from effects of stray electro-magnetic fields
 - guard the resistance from effects of stray electro-static fields
 - none of the above
20. When measuring cable insulation using a dc source, the galvanometer used is initially short circuited to
- discharge the stored charge in the cable
 - bypass the high initial charging current
 - prevent the galvanometer from getting damaged due to low resistance of the cable
 - all of the above
21. The loss of charge method is used for measurement of
- high value capacitances
 - dissipation factor of capacitances
 - low value resistances
 - high value resistances
22. A meggar is used for measurement of
- low value resistances
 - medium value resistances
 - high value, particularly insulation resistances
 - all of the above
23. Controlling torque in a meggar is provided by
- control springs
 - balance weights
 - control coil
 - any one of the above
24. The advantage of Varley loop test over Murray loop test for cable fault localisation is
- the former can be used for localising faults even without knowledge of cable resistance
 - the former can be used for localising both earth fault and short circuit faults
 - the former can experimentally determine the total loop resistance
 - all of the above
25. Possible sources of error in using loop test for cable fault localisation are
- uneven cable resistance/km
 - temperature variations
 - unknown cable joint resistances
 - all of the above

Answers						
1. (c)	2. (a)	3. (b)	4. (c)	5. (d)	6. (a)	7. (a)
8. (a)	9. (b)	10. (a)	11. (c)	12. (d)	13. (d)	14. (d)
15. (d)	16. (b)	17. (b)	18. (c)	19. (a)	20. (b)	21. (d)
22. (c)	23. (c)	24. (a)	25. (d)			

Short-answer Questions

1. Describe the operation of a series-type ohmmeter with the help of a schematic diagram. Comment on the scale markings and zero adjustment procedures in such an instrument.
2. Derive an expression for the meter current as a function of the full-scale deflection value in a series type ohmmeter to determine the shape of scale.
3. Describe the operation of a shunt-type ohmmeter with the help of a schematic diagram. Comment on the scale markings and zero adjustment procedures in such an instrument.
4. Derive an expression for the meter current as a function of the full-scale deflection value in a shunt type ohmmeter to determine the shape of scale.
5. List the sources of errors in a Wheatstone bridge that may affect its precision while measuring medium range resistances. Explain how these effects are eliminated/minimised?
6. What are the different problems encountered while measuring low resistances. Explain how a 4-terminal configuration can minimise these errors while measuring low resistances using a voltmeter–ammeter method.
7. Describe how low resistances can be measured with the help of a potentiometer.
8. Describe with suitable schematic diagram, how a high resistance can be effectively measured using Price’s guard wire method.
9. Explain the principles of the loss of charge method for measurement of high resistances. Also comment on the compensations required to be made in the calculations to take care of circuit component nonidealities.
10. Draw and explain the operation of a meggar used for high resistance measurement.
11. Describe with suitable schematic diagram, the Murray Loop test for localising earth fault in low voltage cables.
12. Describe with suitable schematic diagram, the Varley loop test for localising earth fault in low voltage cables.

Long-answer Questions

1. (a) Discuss with suitable diagrams, the different ways of zero adjustment in a series-type ohmmeter.
(b) Design a single range series-type ohmmeter using a PMMC ammeter that has internal resistance of $60\ \Omega$ and requires a current of $1.2\ \text{mA}$ for full scale deflection. The internal battery has a voltage of $5\ \text{V}$. It is desired to read half scale at a resistance value of $3000\ \Omega$. Calculate (a) the values of shunt resistance and current limiting series resistance, and (b) range of values of the shunt resistance to accommodate battery voltage variation in the range 4.7 to $5.2\ \text{V}$.
2. (a) Describe the operation of a shunt-type ohmmeter with the help of a schematic diagram. Comment on the scale markings and zero adjustment procedures in such an instrument?
(b) A shunt-type ohmmeter uses a $2\ \text{mA}$ basic d’Arsonval movement with an internal resistance of $50\ \Omega$. The battery emf is $3\ \text{V}$. Calculate (a) value of the resistor in series with the battery to adjust the FSD, and (b) at what point (percentage) of full scale will $200\ \Omega$ be marked on the scale?
3. (a) Describe in brief, the use of voltmeter–ammeter method for measurement of unknown resistance.
(b) A voltmeter of $500\ \Omega$ resistance and a milliammeter of $0.5\ \Omega$ resistance are used to measure two unknown resistances by voltmeter–ammeter method. If the voltmeter reads $50\ \text{V}$ and milliammeter reads $50\ \text{mA}$ in both the cases, calculate the percentage error in the values of measured resistances if (i) in the first case, the voltmeter is put across the resistance and the milliammeter connected in series with the supply, and (ii) in the second case, the voltmeter is connected in the supply, side and milliammeter connected directly in series with the resistance.
4. (a) Draw the circuit of a Wheatstone bridge for measurement of unknown resistances and derive the condition for balance.
(b) Four arms of a Wheatstone bridge are as follows: $AB = 150\ \Omega$, $BC = 15\ \Omega$, $CD = 6\ \Omega$, $DA = 60\ \Omega$. A galvanometer with internal resistance of $25\ \Omega$ is connected between BD , while a battery of $20\ \text{V}$ dc is connected between AC . Find the current through the galvanometer. Find the value of the resistance to be put on the arm DA so that the bridge is balanced.
5. (a) Explain the principle of working of a Kelvin’s double bridge for measurement of unknown low resistances. Explain how the effects of contact resistance and resistance of leads are eliminated.

- (b) A 4-terminal resistor was measured with the help of a Kelvin's double bridge having the following components: Standard resistor = $100.02 \mu\Omega$, inner ratio arms = 100.022Ω and 199Ω , outer ratio arms = 100.025Ω and 200.46Ω , resistance of the link connecting the standard resistance and the unknown resistance = $300 \mu\Omega$. Calculate value of the unknown resistance.
6. Discuss the difficulties involved for measurement of high resistances. Explain the purpose of guarding a high resistance measurement circuits.
7. (a) Derive an expression for the unknown resistance measured using the loss of charge method.
- (b) A cable is tested for insulation resistance by loss of charge method. An electrostatic voltmeter is connected between the cable conductor and earth. This combination is found to form a capacitance of 600 pF between the conductor and earth. It is observed that after charging the cable with 1000 V for sufficiently long time, when the voltage supply is withdrawn, the voltage drops down to 480 V in 1 minute. Calculate the insulation resistance of the cable.
8. (a) Describe with suitable schematic diagrams, the Murray loop test for localization of earth fault and short circuit fault in low voltage cables.
- (b) In a test for fault to earth by Murray loop test, the faulty cable has a length of 6.8 km . The faulty cable is looped with a sound (healthy) cable of the same length and cross section. Resistances of the ratio arm of the measuring bridge circuit are 200Ω and 444Ω at balance. Calculate the distance of the fault point from the testing terminal.
9. (a) Describe with suitable schematic diagrams, the Varley loop test for localisation of earth fault and short-circuit fault in low voltage cables.
- (b) Varley loop test is being used to locate short circuit fault. The faulty and sound cables are identical with resistances of 0.4Ω per km. The ratio arms are set at 20Ω and 50Ω . Values of the variable resistance connected with the faulty cable are 30Ω and 15Ω at the two positions of the selector switch. Determine the length of each cable and fault distance from test end.

5

Potentiometers

5.1

INTRODUCTION

A potentiometer is an instrument which is used for measurement of potential difference across a known resistance or between two terminals of a circuit or network of known characteristics. A potentiometer is also used for comparing the emf of two cells. A potentiometer is extensively used in measurements where the precision required is higher than that can be obtained by ordinary deflecting instruments, or where it is required that no current be drawn from the source under test, or where the current must be limited to a small value.

Since a potentiometer measures voltage by comparing it with a standard cell, it can be also used to measure the current simply by measuring the voltage drop produced by the unknown current passing through a known standard resistance. By the potentiometer, power can also be calculated and if the time is also measured, energy can be determined by simply multiplying the power and time of measurement. Thus potentiometer is one of the most fundamental instruments of electrical measurement.

Some important characteristics of potentiometer are the following:

- A potentiometer measures the unknown voltage by comparing it with a known voltage source rather than by the actual deflection of the pointer. This ensures a high degree of accuracy.
- As a potentiometer measures using null or balance condition, hence no power is required for the measurement.
- Determination of voltage using potentiometer is quite independent of the source resistance.

5.2

A BASIC dc POTENTIOMETER

The circuit diagram of a basic dc potentiometer is shown in [Figure 5.1](#).

Operation

First, the switch S is put in the 'operate' position and the galvanometer key K kept open, the battery supplies the working current through the rheostat and the slide wire. The working current through the slide wire may be varied by changing the rheostat setting. The method of measuring the unknown voltage, E_1 , depends upon the finding a position for the sliding contact such that the galvanometer shows zero deflection, i.e., indicates null

condition, when the galvanometer key K is closed. Zero galvanometer deflection means that the unknown voltage E_1 is equal to the voltage drop E_2 , across position $a-c$ of the slide wire. Thus, determination of the values of unknown voltage now becomes a matter of evaluating the voltage drop E_2 along the portion $a-c$ of the slide wire.

When the switch S is placed at 'calibrate' position, a standard or reference cell is connected to the circuit. This reference cell is used to standardize the potentiometer. The slide wire has a uniform cross-section and hence uniform resistance along its entire length. A calibrated scale in cm and fractions of cm, is placed along the slide wire so that the sliding [Figure 5.1](#) A basic potentiometer circuit contact can be placed accurately at any desired position along the slide wire. Since the resistance of the slide wire is known accurately, the voltage drop along the slide wire can be controlled by adjusting the values of working current. The process of adjusting the working current so as to match the voltage drop across a portion of sliding wire against a standard reference source is known as 'standardisation'.

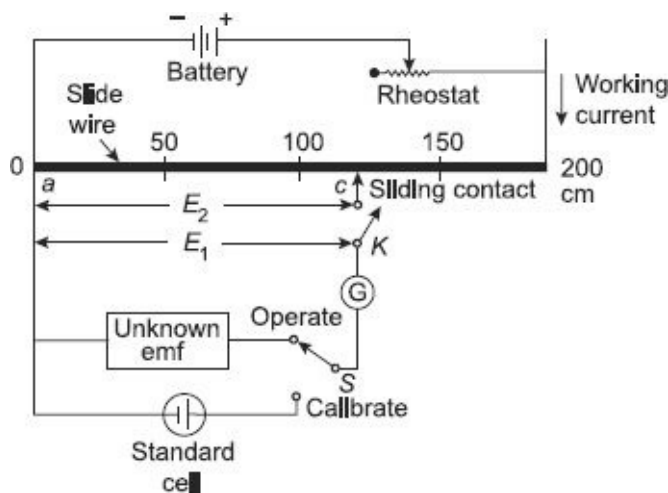

Figure 5.1 A basic potentiometer circuit

5.3

CROMPTON'S dc POTENTIOMETER

The general arrangement of a laboratory-type Crompton's dc potentiometer is shown in [Figure 5.2](#). It consists of a dial switch which has fifteen (or more) steps. Each step has $10\ \Omega$ resistance. So the dial switch has total $150\ \Omega$ resistance. The working current of this potentiometer is $10\ \text{mA}$ and therefore each step of dial switch corresponds to 0.1 volt. So the range of the dial switch is 1.5 volt.

The dial switch is connected in series with a circular slide wire. The circular slide wire has $10\ \Omega$ resistance. So the range of that slide wire is 0.1 volt. The slide wire calibrated with 200 scale divisions and since the total resistance of slide wire corresponds to a voltage drop of 0.1 volt, each division of the slide wire corresponds to $\frac{0.1}{200} = 0.0005$ volt. It is quite comfortable to interpolate readings up to $\frac{1}{5}$ of a scale division and therefore with this Crompton's potentiometer it is possible to estimate the reading up to 0.0001 volt.

Procedure for Measurement of Unknown emf

- At first, the combination of the dial switch and the slide wire is set to the standard cell voltage. Let the standard cell voltage be 1.0175 volts, then the dial resistor is put in 1.0 volt and the slide wire at 0.0175 volts setting.
- The switch 'S' is thrown to the calibrate position and the galvanometer switch 'K' is pressed until the rheostat is adjusted for zero deflection on the galvanometer. The 10 kW protective resistance is kept in the circuit in the initial stages so as to protect the galvanometer from overload.
- After the null deflection on the galvanometer is approached the protective resistance is shorted so as to increase the sensitivity of the galvanometer. Final adjustment is made for the zero deflection with the help of the rheostat. This completes the standardisation process of the potentiometer.
- After completion of the standardisation, the switch 'S' is thrown to the operate position thereby connecting the unknown emf into the potentiometer circuit. With the protective resistance in the circuit, the potentiometer is balanced by means of the main dial and the slide wire adjustment.
- As soon as the balanced is approached, the protective resistance is shorted and final adjustments are made to obtain true balance.
- After the final true balance is obtained, the value of the unknown emf is read off directly from the setting of the dial switch and the slide wire.
- The standardisation of the potentiometer is checked again by returning the switch 'S' to the calibrate position. The dial setting is kept exactly the same as in the original standardisation process. If the new reading does not agree with the old one, a second measurement of unknown emf must be made. The standardisation again should be made after the measurement.

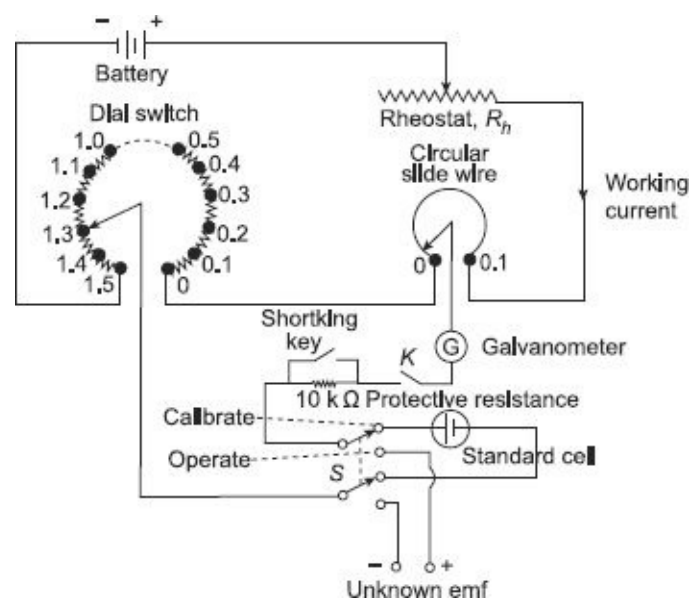

Figure 5.2 General arrangement of Crompton's dc potentiometer

A basic slide-wire potentiometer has a working battery

Example 5.1

voltage of 3.0 volts with negligible resistance. The resistance of the slide-wire is $400\ \Omega$ and its length is 200 cm. A 200-cm scale is placed along the slide wire. The slide-wire has 1 mm scale divisions and it is possible to read up to $1/5$ of a division. The instrument is standardised with 1.018 volt standard cell with with sliding contact at the 101.8 cm mark on scale.

Calculate

- (a) Working current
- (b) Resistance of series rheostat
- (c) Measurement range
- (d) Resolution of the instrument

Solution

(a) Working current, I_m

Because the instrument is standardised with an emf of 1.018 volts with sliding contact at 101.8 cm, it is obvious that a length 101.8 cm represents a voltage of 1.018 volts.

$$\text{Resistance of 101.8 cm length of wire} = \frac{1.018}{200} \times 400 = 203.6\ \Omega$$

$$\therefore \text{working current, } I_m = \frac{101.8}{203.6} = 0.005\ \text{A or 5 mA.}$$

(b) Resistance of series rheostat, R_h

Total resistance of battery circuit = Resistance of rheostat (R_h) + Resistance of slide wire.

$$\therefore R_h = \text{Total resistance} - \text{Resistance of slide wire}$$

$$= \frac{3}{0.005} - 400 = 200\ \Omega$$

(c) Measurement range

The measurement range is the total voltage across the slide wire.

$$\therefore \text{range of voltage} = 0.005 \times 400 = 2.0\ \text{volt.}$$

(d) Resolution of the instrument

A length of 200 cm represents 2.0 volt and therefore 1 mm represents a voltage of $\hat{2} \hat{1}$

$$\left(\frac{2}{200}\right) \times \left(\frac{1}{10}\right) = 1\ \text{mV}$$

Since it is possible to read $\frac{1}{5}$ of 1 mV, therefore, resolution of the instrument is $\frac{1}{5} \times 1 = 0.2\ \text{mV}$

A single-range laboratory-type potentiometer has an 18-step dial switch where each step represents 0.1 volt. The

Example 5.2

dial resistors are 10Ω each. The slide wire of the potentiometer is circular and has 11 turns and a resistance of 1Ω per turn. The slide wire has 100 divisions and interpolation can be done to one fourth of a division. The working battery has a voltage of 6.0 volt. Calculate (a) the measuring range of the potentiometer, (b) the resolution, (c) working current, and (d) setting of the rheostat.

Solution Dial resistor = 10Ω each

Each step = 0.1 v

$$\therefore \text{working current} = \frac{0.1}{10} = 10 \text{ mA}$$

(a) The measuring range of the potentiometer

Total resistance of measuring circuit,

$$R_m = \text{Resistance of dial} + \text{resistance of slide wire}$$

or, $R_m = 18 \times 10 + 11 = 191$

voltage range of the total instrument

$$= R_m \times \text{working current}$$

$$= 191 \times 10 \text{ mA}$$

$$= 1.91 \text{ V}$$

(b) The resolution

The slide wire has a resistance of 11Ω and therefore voltage drop across slide wire

$$= 11 \times 10 \text{ mA} = 0.11 \text{ volt}$$

The slide wire has 11 turns, and therefore voltage drop across each turn

$$= \frac{0.11}{11} = 0.01 \text{ volt}$$

Each turn is divided into 100 divisions and therefore each division represents a voltage drop of $\frac{0.01}{100} = 0.0001$.

Since each turn can be interpolated to of a division,

$$\text{Resolution of instrument} = 0.0001 \times 0.25 = 0.000025 \text{ volt} = 25 \text{ mV}$$

(c) Working current, I_m

As previously mentioned, working current = 10 mA .

(d) Setting of rheostat

$$\text{Total resistance across battery circuit} = \frac{6}{0.01} = 600 \Omega$$

Total resistance of potentiometer circuit is 191Ω

∴ resistance of series rheostat, $R_h = 600 - 191 = 409 \text{ W}$.

5.4

APPLICATIONS OF dc POTENTIOMETERS

Practical uses of dc potentiometers are

- Measurement of current
- Measurement of high voltage
- Measurement of resistance
- Measurement of power
- Calibration of voltmeter
- Calibration of ammeter
- Calibration of wattmeter

5.4.1 Measurement of Current by Potentiometer

The circuit arrangement for measurement of current by a potentiometer is shown in [Figure 5.3](#). The unknown current I , whose value is to be measured, is passed through a standard resistor R as shown. The standard resistor should be of such a value that voltage drop across it caused by flow of current to be measured, may not exceed the range of the potentiometer. Voltage drop across the standard resistor in volts divided by the value of R in ohms gives the value of unknown current in amperes.

$$\text{i.e., unknown current (in Amp) } I = \frac{\text{Voltage drop across } R \text{ (Volt)}}{\text{Value of } R \text{ (ohms)}}$$

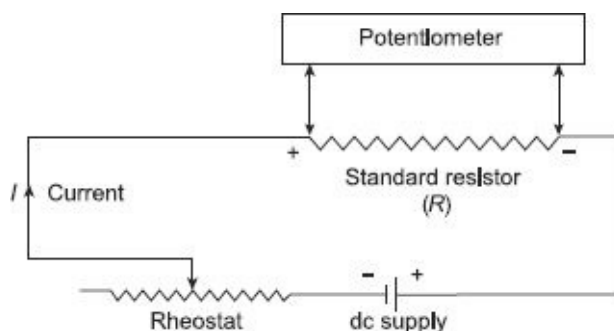

Figure 5.3 Measurement of current with potentiometer

Example 5.3

A simple slide wire potentiometer is used for measurement of current in a circuit. The voltage drop across a standard resistor of 0.1Ω is balanced at 75 cm. find the magnitude of the current if the standard cell emf of 1.45 volt is balanced at 50 cm.

Solution For the same working current, if 50 cm corresponds to 1.45 volt. Then 75 cm of the slide wire corresponds to

$$= \frac{1.45}{50} \times 75 = 2.175 \text{ volt}$$

So, across the resistance 0.1 Ω the voltage drop is 2.175 volt. Then the value of the current is

$$I = \frac{2.175}{0.1} = 21.75 \text{ A}$$

5.4.2 Measurement of High Voltage by Potentiometer

Special arrangements must be made to measure very high voltage by the potentiometer (say a hundreds of volts) as this high voltage is beyond the range of normal potentiometer. The voltage above the direct range of potentiometer (generally 1.8 volt) can be measured by using a volt-ratio box in conjunction with the potentiometer. The volt-ratio box consists of a simple resistance potential divider with various tapping on the input side. The arrangement is shown in Figure 5.4. Each input terminal is marked with the maximum voltage which can be applied and with the corresponding multiplying factor for the potential scale.

High emf to be measured is applied the suitable input terminal of volt-ratio box and leads to the potentiometer are taken from two tapping points intended for this purpose.

The potential difference across these two points is measured by the potentiometer. If the voltage measured by the potentiometer is v and k be the multiplying factor of the volt-ratio box, then the high voltage to be measured is $V = kv$ volt.

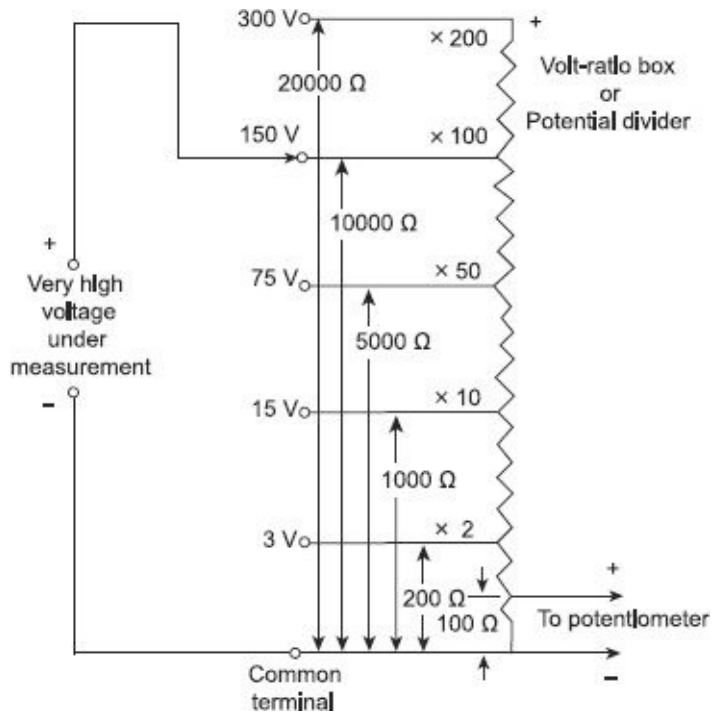

Figure 5.4 Measurement of high voltage by potentiometer in conjunction with volt-ratio box

5.4.3 Measurement of Resistance by Potentiometer

The connection diagram for measuring unknown resistance with the help of potentiometer is shown in Figure 5.5. The unknown resistance R , is connected in series with the known standard resistor S . The rheostat connected in the circuit controls the current flowing through the circuit. An ammeter is also connected in the circuit to indicate whether the value of the working current is within the limit of the potentiometer or not. Otherwise, the exact value of the working current need not be known.

When the two-pole double throw switch is put in position 1, the unknown resistance is connected to the potentiometer. Let the reading of the potentiometer in that position is V_R . Then

$$V_R = IR \tag{5.1}$$

Now the switch is thrown to position 2, this connects the standard resistor S to the potentiometer. If the reading of the potentiometer is that position is V_S then,

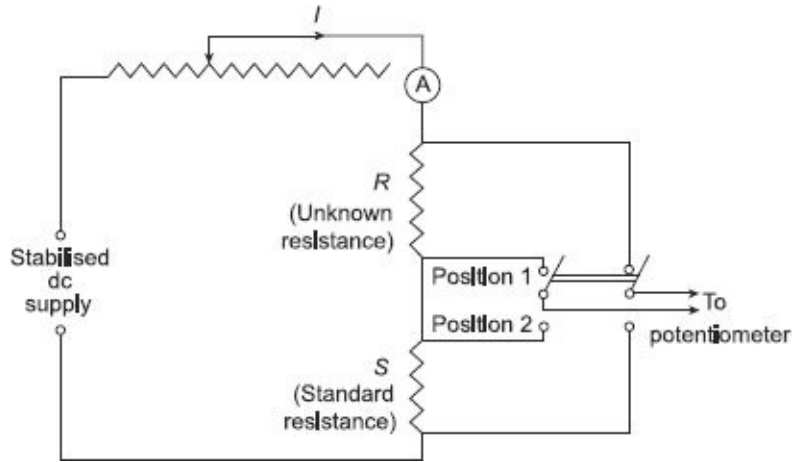

Figure 5.5 Measurement of resistance by potentiometer

$$V_S = IS \tag{5.2}$$

Dividing (5.1) by (5.2), we get

$$\frac{V_R}{V_S} = \frac{IR}{IS}$$

or
$$R = \frac{V_R}{V_S} \times S$$

The value of R can be calculated accurately since the value of the standard resistor S is known. This method of measurement of resistance is used for low value of the resistor.

5.4.4 Measurement of Power by Potentiometer

In measurement of power by potentiometer the measurements are made one across the standard resistor S connected in series with the load and another across the volt-ratio box output terminals. The arrangement is shown in [Figure 5.6](#).

The load current which is exactly equal to the current through the standard resistor S , as it is connected in series with the load, is calculated from the voltage drop across the standard resistor divided by the value of the standard resistor S .

$$\text{Load current } I = \frac{V_S}{S}$$

where V_S = voltage drop across standard resistor S as measured by the potentiometer.

Voltage drop across the load is found by the output terminal of the volt-ratio box. If V_R is the voltage drop across the output terminal of the volt-ratio box and V_L is the voltage drop across load then,

$$V_L = k \times V_R$$

where k is the multiplying factor of the volt-ratio box.

Then the power consumed, $P = V_L I = k \times V_R \times \frac{V_S}{S}$

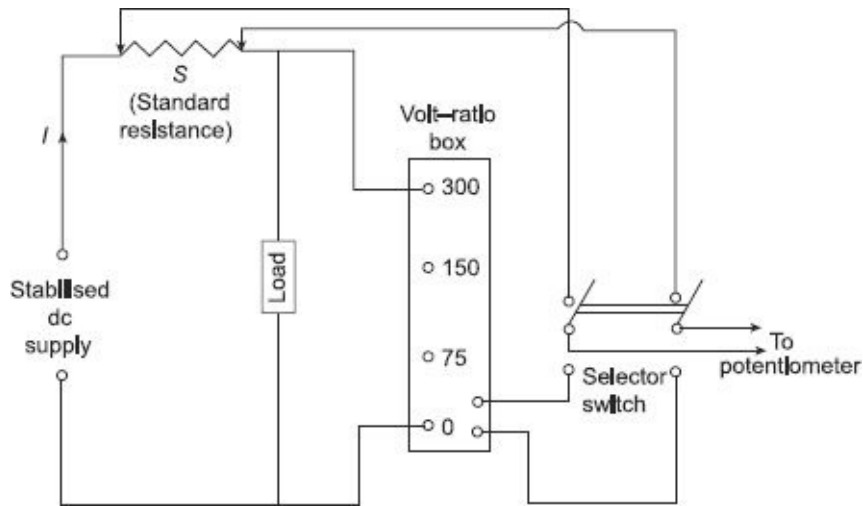

Figure 5.6 Measurement of power by potentiometer

5.4.5 Calibration of Voltmeter by Potentiometer

In case of calibration of voltmeter, the main requirement is that a suitable stable dc voltage supply is available, otherwise any change in the supply voltage will cause a change in the calibration process of the voltmeter.

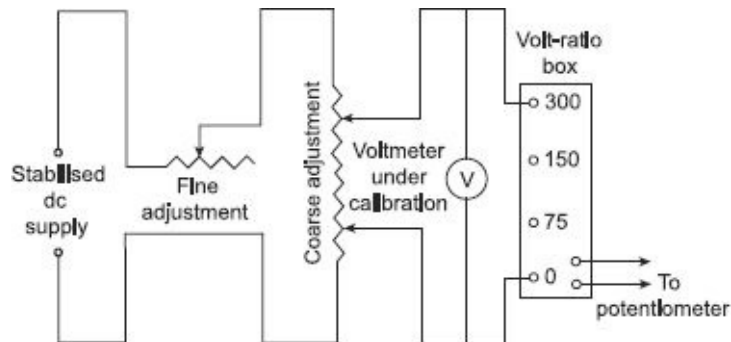

Figure 5.7 Calibration of voltmeter by potentiometer

The arrangement for calibrating a voltmeter by potentiometer is shown in Figure 5.7. The potential divider network consists of two rheostats. One for coarse and the other for fine control of calibrating voltage. With the help of these controls, it is possible to adjust the supply voltage so that the pointer coincides exactly with a major division of the voltmeter.

The voltage across the voltmeter is stepped down to a value suitable for the potentiometer with the help of the volt-ratio box. In order to get accurate measurements, it is necessary to measure voltages near the maximum range of the potentiometer, as far as possible.

The potentiometer measures the true value of the voltage. If the reading of the potentiometer does not match with the voltmeter reading, a positive or negative error is indicated. A calibration curve may be drawn with the help of the potentiometer and the voltmeter reading.

5.4.6 Calibration of Ammeter by Potentiometer

Figure 5.8 shows the circuit arrangement for calibration of an ammeter using

potentiometer.

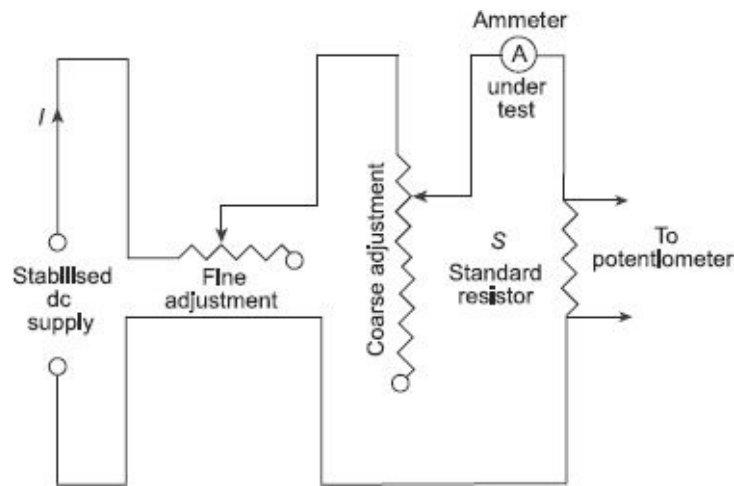

Figure 5.8s Calibration of ammeter by potentiometer

A standard resistor S of high current carrying capacity is placed in series with the ammeter under test. The voltage drop across S measured with the help of the potentiometer and then the current through S and hence the ammeter can be computed by dividing the voltage drop by the value of the standard resistor.

Current, $I = \frac{V_S}{S}$ is the voltage drop across the standard resistor S .

Now, compare the reading of the ammeter with the current found by calculation. If they do not match, a positive or negative error will be induced. A calibration curve may be drawn between the ammeter reading and the true value of the current as indicated by the potentiometer reading.

As the resistance of the standard resistor S is exactly known, the current through S is exactly calculated. This method of calibration of ammeter is very accurate.

5.4.7 Calibration of Wattmeter by Potentiometer

In this calibration process, the current coil of the wattmeter is supplied from low voltage supply and potential coil from the normal supply through potential divider. The voltage V across the potential coil of the wattmeter under calibration is measured directly by the potentiometer. The current through the current coil is measured by measuring the voltage drop across a standard resistor connected in series with the current coil divided by the value of the standard resistor.

The true power is then VI , where V is the voltage across the potential coil and I is the current through the current coil of the wattmeter. The wattmeter reading may be compared with this value, and a calibration curve may be drawn.

The arrangement for calibrating a wattmeter is shown in [Figure 5.9](#).

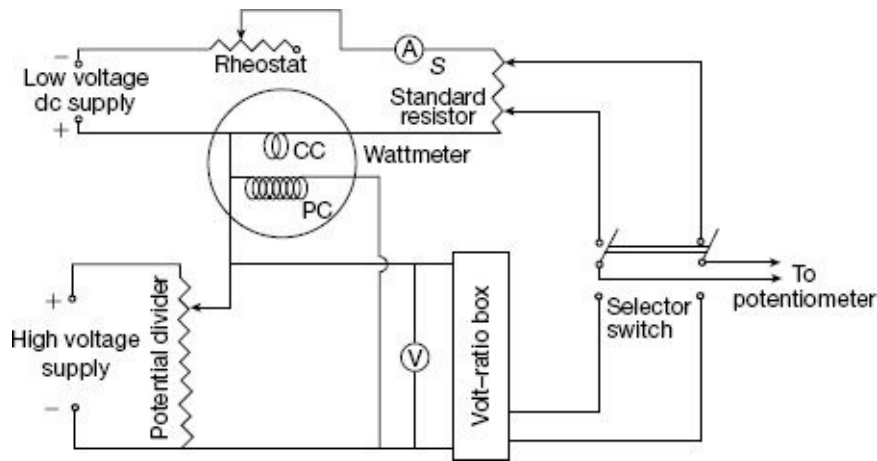

Figure 5.9 Calibration of wattmeter by dc potentiometer

Example 5.4

The emf of a standard cell used for standardisation is 1.0186 volt. If the balanced is achieved at a length of 55 cm, determine

- The emf of the cell which balances at 70 cm
- The current flowing through a standard resistance of 2Ω if the potential difference across it balances at 60 cm
- The voltage of a supply main which is reduced by a volt-ratio box to one hundredth and balance is obtained at 85 cm
- The percentage error in a voltmeter reading 1.40 volt when balance is obtained at 80 cm
- The percentage error in ammeter reading 0.35 ampere when balance is obtained at 45 cm with the potential difference across a 2.5Ω resistor in the ammeter circuit

Solution Emf of the standard cell = 1.0186 volts

The voltage drop per cm length of potentiometer wire,

$$v = \frac{1.0186}{55} = 0.01852$$

- (a) The emf of a cell balanced at 70 cm,

$$= v \cdot l = 0.01852 \times 70 = 1.2964 \text{ volt}$$

- (b) The potential difference which is balanced at 60 cm

$$= v \cdot l = 0.01852 \times 60 = 1.1112 \text{ volt}$$

Magnitude of the standard resistor, $S = 2 \text{ W}$

Therefore, current flowing through 2Ω resistance V

$$= \frac{V}{S} = \frac{1.1112}{2} = 0.5556 \text{ A}$$

- (c) The potential difference which balances at 85 cm,

$$V = v \cdot l = 0.01852 \times 85 = 1.5742 \text{ volt}$$

voltage of supply main = $V \times$ ratio of volt–ratio box

$$1.5742 \times 100 = 157.42 \text{ volt}$$

(d) The potential difference which balances at 80 cm,

$$V = v \cdot l = 0.01852 \times 80 = 1.4816 \text{ volt}$$

Voltmeter reading = 1.40 volt

percentage error in voltmeter reading

$$= \frac{1.4 - 1.4816}{1.4816} \times 100 = -5.507\%$$

(e) The potential difference which balances at 45 cm,

$$V = v \cdot l = 0.01852 \times 45 = 0.8334 \text{ volt}$$

Current flowing through 2.5Ω resistance V 0.8334

$$I = \frac{V}{S} = \frac{0.8334}{2.5} = 0.33336 \text{ A}$$

percentage error in ammeter reading

$$= \frac{0.35 - 0.33336}{0.33336} \times 100 = 4.991\%$$

The following readings were obtained during the measurement of a low resistance using a potentiometer:

Voltage drop across a 0.1Ω standard resistance = 1.0437 V

Voltage drop across the low resistance under test = 0.4205 V

Calculate the value of unknown resistance, current and power lost in it.

Example 5.5

Solution Given: $S = 0.1 \Omega$; $V_S = 1.0437 \text{ V}$; $V_R = 0.4205 \text{ V}$

Resistance of unknown resistor, $R = \frac{V_R}{V_S} \times S = \frac{0.4205}{1.0437} \times 0.1 = 0.04 \Omega$

Current through the resistor, $I = \frac{V_S}{S} = \frac{1.0437}{0.1} = 10.437 \text{ A}$

Power loss, $PI^2 R = (10.437)^2 \times 0.04 = 4.357 \text{ Wa}$

Example 5.6

A Crompton's potentiometer consists of a resistance dial having 15 steps of 10Ω each and a series connected slide wire of 10Ω which is divided into 100 divisions. If the working current of the potentiometer is 10 mA and each division of slide wire can be read accurately upto $1/5$ th of its span, calculate the resolution of the potentiometer in volts.

Solution Total resistance of the potentiometer,

$$\begin{aligned} R &= \text{Resistance of the dial} + \text{Resistance of the slide wire} \\ &= 15 \times 10 + 10 = 160 \text{ W} \end{aligned}$$

Working current, $I = 10 \text{ mA} = 0.01 \text{ A}$

Voltage range of the potentiometer = Working current \times Total resistance of the potentiometer

$$= 0.01 \times 160 = 1.6$$

Voltage drop across slide wire = Working current \times Slide wire resistance

$$= 0.01 \times 10 = 0.1 \text{ V}$$

Since slide wire has 100 divisions, therefore, each division represents $\frac{0.1}{100}$ or 0.001 volt

As each division of slide wire can be read accurately up to $\frac{1}{5}$ potentiometer of its span, therefore, resolution of the potentiometer

$$= \frac{0.001}{5} = 0.0002 \text{ volt}$$

5.5

POTENTIOMETERS

An ac potentiometer is same as dc potentiometer by principle. Only the main difference between the ac and dc potentiometer is that, in case of dc potentiometer, only the magnitude of the unknown emf is compared with the standard cell emf, but in ac potentiometer, the magnitude as well as phase angle of the unknown voltage is compared to achieve balance.

This condition of ac potentiometer needs modification of the potentiometer as constructed for dc operation.

The following points need to be considered for the satisfactory operation of the ac potentiometer:

1. To avoid error in reading, the slide wire and the resistance coil of an ac potentiometer should be non-inductive.
2. The reading is affected by stray or external magnetic field, so in the time of measurement they must be eliminated or measured and corresponding correction factor should be introduced.
3. The sources of ac supply should be free from harmonics, because in presence of harmonics the balance may not be achieved.
4. The ac source should be as sinusoidal as possible.
5. The potentiometer circuit should be supplied from the same source as the voltage or current being measured.

5.6

CLASSIFICATION OF AC POTENTIOMETERS

There are two general types of ac potentiometers:

1. Polar Potentiometer

As the name indicates, in these potentiometers, the unknown emf is measured in polar form, i.e., in terms of its magnitude and relative phase. The magnitude is indicated by one scale and the phase with respect to some reference axis is indicated by another scale. There is provision for reading phase angles up to 360° .

The voltage is read in the form $V - \theta$.

Example: Drysdale polar potentiometer

2. Coordinate Potentiometer

Here, the unknown emf is measured in Cartesian form. Two components along and perpendicular to some standard axis are measured and indicated directly by two different scales known as in phase (V_1) and quadrature (V_2) scales (Figure 5.10). Provision is made in this instrument to read both positive and negative values of voltages so that all angles up to 360° are covered.

$$\text{Voltage } V = \sqrt{(V_1)^2 + (V_2)^2}; \theta = \tan^{-1} \left(\frac{V_2}{V_1} \right)$$

Example: Gall–Tinsley and Campbell–Larsen type potentiometer

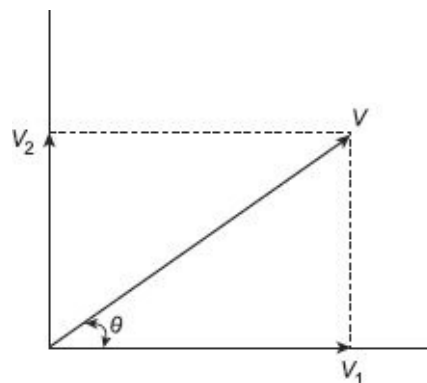

Figure 5.10 Polar and coordinate representation of unknown emf

5.6.1 Drysdale Polar Potentiometer

The different components of a Drysdale polar potentiometer is shown in Figure 5.11.

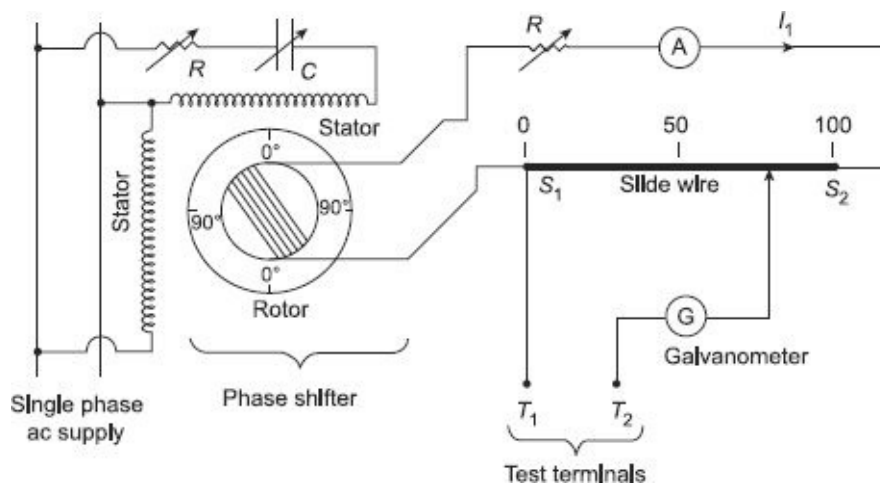

Figure 5.11 Drysdale polar potentiometer

The slide wire S_1-S_2 is supplied from a phase shifting circuit for ac measurement. The phase shifting circuit is so arranged that the magnitude of the voltage supplied by it remains constant while its phase can be varied through 360° . Consequently, slide wire current can be maintained constant in magnitude but varied in phase.

The phase shifting circuit consists of two stator coils connected in parallel supplied from the same source; their currents are made to differ by 90° by using very accurate phase shifting technique. The two windings produce rotating flux which induces a secondary emf in the rotor winding which is of constant magnitude but the phase of which can be varied by rotating the rotor in any position. The phase of the rotor emf is read from the circular dial attached in the potentiometer.

Before the ac measurement, the potentiometer is first calibrated by using dc supply for slide wire and standard cell for test terminals T_1 and T_2 . The unknown alternating voltage to be measured is applied across test terminals and the balance is achieved by varying the slide wire contact and the position of the rotor. The ammeter connected in the slide wire circuit gives the magnitude of the unknown emf and the circular dial in the rotor circuit gives the phase angle of it.

5.6.2 Gall Coordinate Potentiometer

The Gall coordinate potentiometer consists of two separate potentiometer circuit in a single case. One of them is called the '*in-phase*' potentiometer and the other one is called the *quadrature* potentiometer. The slide-wire circuits of these two potentiometers are supplied with two currents having a phase difference of 90° . The value of the unknown voltage is obtained by balancing the voltages of *in-phase* and *quadrature* potentiometers slide wire simultaneously. If the measured values of *in-phase* and *quadrature* potentiometer slide-wires are V_1 and V_2 respectively then the magnitude of the unknown voltage is $V = \sqrt{V_1^2 + V_2^2}$ and the phase angle of the unknown voltage is given by $q = \tan^{-1} \frac{V_2}{V_1}$.

Figure 5.12 shows the schematic diagram of a Gall coordinate-type potentiometer. $W-X$ and $Y-Z$ are the sliding contacts of the *in-phase* and *quadrature* potentiometer respectively. R and R' are two rheostats to control the two slide-wire currents. The *in-phase* potentiometer slide-wire is supplied from a single-phase supply and the *quadrature* potentiometer slide-wire is supplied from a phase-splitting device to create a phase difference of 90° between the two slide-wire currents. T_1 and T_2 are two step-down transformers having an output voltage of 6 volts. These transformers also isolate the potentiometer from the high-voltage supply. R and C are the variable resistance and capacitance for phase-splitting purpose. VG is a vibration galvanometer which is tuned to the supply frequency and K is the galvanometer key. A is a dynamometer ammeter which is used to display the current in both the slide-wires so that they can be maintained at a standard value of 50 mA. SW_1 and SW_2 are two *sign-changing* switches which may be necessary to reverse the direction of unknown emf applied to the slide wires. SW_3 is a selector switch and it is used to apply the unknown voltage to the potentiometer.

Operation Before using the potentiometer for ac measurements, the current in the *in-*

phase potentiometer slide wire is first standardised using a standard dc cell of known value. The vibration galvanometer VG is replaced by a D'Arsonval galvanometer. Now the *in-phase* slide wire current is adjusted to the standard value of 50 mA by varying the rheostat R . This setting is left unchanged for ac calibration; the dc supply is replaced by ac and the D'Arsonval galvanometer by the vibration galvanometer.

The magnitude of the current in the quadrature potentiometer slide wire must be equal to the *in-phase* potentiometer slide wire current and the two currents should be exactly in quadrature. The switch SW_3 is placed to *test position* (as shown in Figure 5.12) so that the emf induced in the secondary winding of mutual inductance M is impressed across the *in-phase* potentiometer wire through the vibration galvanometer. Since the induced emf in the secondary of mutual inductance M will be equal to $2pfMi$ volt in magnitude; where f is the supply frequency and will lag 90° behind the current in the quadrature slide-wire i , so the value of emf calculated from the relation $e' = 2pf Mi$ for a current $i = 50$ mA is set on *in-phase* potentiometer slide wire and R' are adjusted till exact balance point is obtained. At balance position, the current in the potentiometer wires will be exactly equal to 50 mA in magnitude and exactly in quadrature with each other. The polarity difference between the two circuits is corrected by changing switches SW_1 and SW_2 .

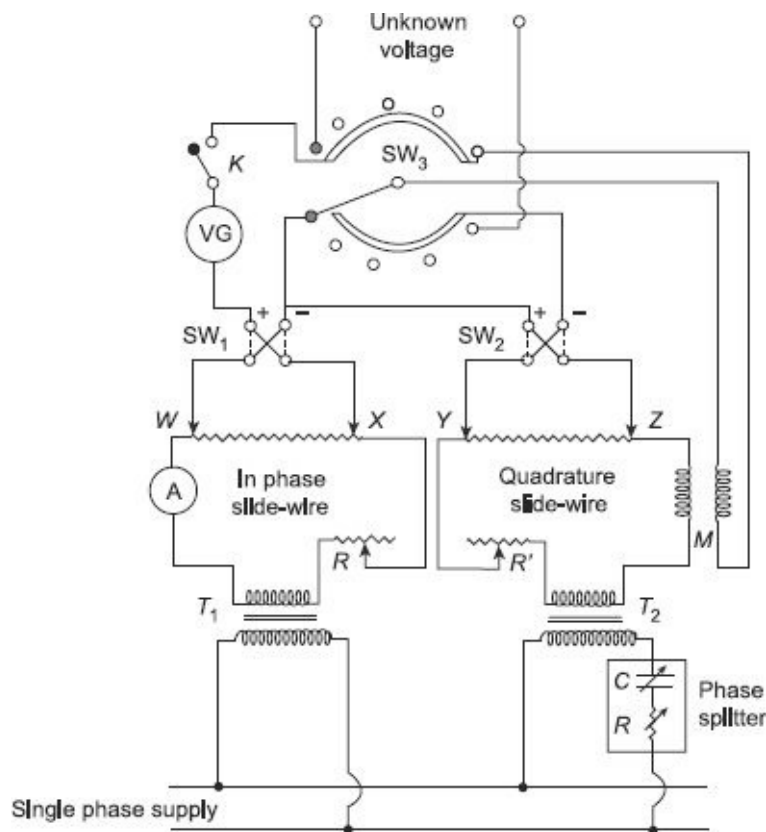

Figure 5.12 Gall coordinate potentiometer

Lastly, the unknown voltage is applied to the potentiometer by means of the switch SW_3 and balance is obtained on both the potentiometer slide-wire by adjusting the slide-wire setting. The reading of slide-wire WX gives the *in-phase* component (V_1) and slide wire YZ gives quadrature component (V_2) of the unknown voltage.

ADVANTAGES AND DISADVANTAGES OF ac

Advantages

1. An ac potentiometer is a very versatile instrument. By using shunt and volt–ratio box, it can measure wide range of voltage, current and resistances.
2. As it is able to measure phase as well as magnitude of two signals, it is used to measure power, inductance and phase angle of a coil, etc.
3. The principle of ac potentiometer is also incorporated in certain special application like Arnold circuit for the measurement of CT (Current Transformer) errors.

Disadvantages

1. A small difference in reading of the dynamometer instrument either in dc or ac calibration brings on error in the alternating current to be set at standard value.
2. The normal value of the mutual inductance M is affected due to the introduction of mutual inductances of various potentiometer parts and so a slight difference is observed in the magnitude of the current of quadrature wire with compared to that in the in–phase potentiometer wire.
3. Inaccuracy in the measured value of frequency will also result in the quadrature potentiometer wire current to differ from that of in–phase potentiometer wire.
4. The presence of mutual inductances in the various parts of the potentiometer and the inter capacitance, the potential gradient of the wires is affected.
5. Since the standardisation is done on the basis of rms value and balance is obtained dependent upon the fundamental frequency only, therefore, the presence of harmonics in the input signal introduces operating problem and the vibration galvanometer tuned to the fundamental frequency may not show full null position at all.

The major applications of the ac potentiometers are

1. Measurement of self-inductance
2. Calibration of voltmeter
3. Calibration of ammeter
4. Calibration of wattmeter

5.8.1 Measurement of Self–inductance

The circuit diagram for measurement of self inductance of a coil by ac potentiometer is shown in [Figure 5.13\(a\)](#). A standard non-inductive resistor is connected in series with the coil under test and two potential differences V_1 and V_2 are measured in magnitude and phase by the potentiometer.

The vector diagram is shown in [Figure 5.13\(b\)](#). Refer to this figure.

Voltage drop across standard resistor $R_S, V_2 = IR_S$

where, I = current flowing through the circuit, and

R_S = resistance of the standard non-inductive resistor

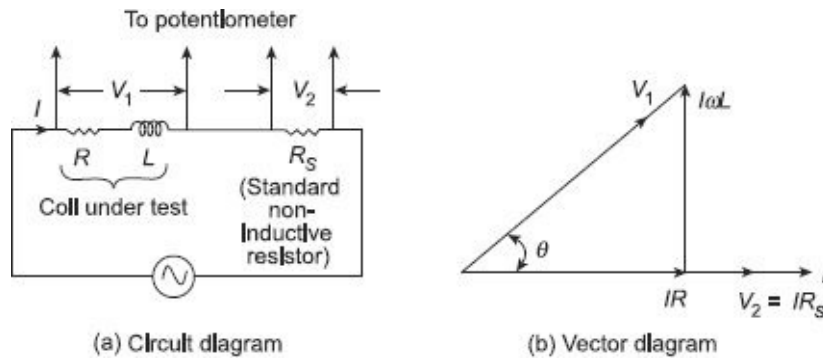

Figure 5.13 Measurement of self-inductance by ac potentiometer

or,
$$I = \frac{V_2}{R_S}$$

Voltage drop across inductive coil = V_1

Phase angle between voltage across and current through the coil = θ

Voltage drop due to resistance of coil, $IR = V_1 \cos \theta$

$$\therefore \text{resistance of the coil, } R = \frac{V_1 \cos \theta}{I} = \frac{V_1 \cos \theta}{\frac{V_2}{R_S}} = \frac{R_S V_1 \cos \theta}{V_2}$$

Voltage drop due to inductance of coil, $I\omega L = V_1 \sin \theta$

$$\therefore \text{inductance of the coil, } L = \frac{V_1 \sin \theta}{I\omega} = \frac{V_1 \sin \theta}{\omega \left(\frac{V_2}{R_S} \right)} = \frac{R_S V_1 \sin \theta}{V_2 \omega}$$

5.8.2 Calibration of Ammeter

The method of calibration of an ac ammeter is similar to dc potentiometer method for dc ammeter (refer to Section 5.4.6) i.e., ac ammeter under calibration is connected in series with a non inductive variable resistance for varying the current, and a non-inductive standard resistor and voltage drop across standard resistor is measured on ac potentiometer. However, the standardising of the ac potentiometer involves the use of a suitable transfer instrument.

5.8.3 Calibration of Voltmeter

The method of calibration of an ac voltmeter by using ac potentiometer is similar to that adopted for calibration of dc voltmeter by using dc potentiometer (refer Section 5.4.5).

5.8.4 Calibration of Wattmeter

The circuit diagram for calibration of wattmeter by ac potentiometer is shown in [Figure 5.14](#). The calibration process is same that adopted in case of calibration of wattmeter by dc potentiometer (refer Section 5.4.7).

The current coil of the wattmeter is supplied through a stepdown transformer and the potential coil from the secondary of a variable transformer whose primary is supplied from the rotor of a phase shifting transformer.

The voltage V across the potential coil of the wattmeter and the current I through the current coil of wattmeter are measured by the potentiometer, introducing a volt-ratio box and a standard resistor as shown in Figure 5.14.

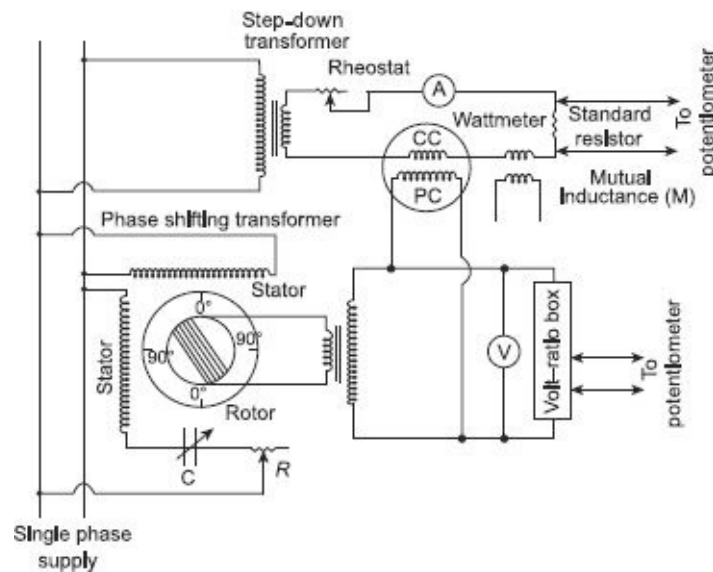

Figure 5.14 Calibration of wattmeter by ac potentiometer

The power factor $\cos q$ is varied by rotating the phase shift rotor, the phase angle between voltage and current, F being given by the reading on the dial of the phase shifter. The power is then $VI \cos F$ and the wattmeter reading may be compared with this reading. A calibration curve may be drawn if necessary. A small mutual inductance M is included to ensure accuracy of measurement of zero power factor.

Example 5.7

The following readings were obtained during measurement of inductance of a coil on an ac potentiometer: Voltage drop across 0.1Ω standard resistor connected in series with the coil = $0.613 \angle 12^\circ 6'$ Voltage across the test coil through a 100:1 volt-ratio box = $0.781 \angle 50^\circ 48'$ Frequency 50 Hz. Determine the value of the inductance of the coil.

Solution

$$\text{Current through the coil } = \bar{I} = \frac{0.613 \angle 12^\circ 6'}{0.1} = 6.13 \angle 12^\circ 6' \text{ A}$$

$$\text{Voltage across the coil } \bar{V} = 100 \times 0.781 \angle 50^\circ 48' = 78.1 \angle 50^\circ 48' \text{ V}$$

$$\therefore \text{impedance of the coil } \bar{Z} = \frac{\bar{V}}{\bar{I}} = \frac{78.1 \angle 50^\circ 48'}{6.13 \angle 12^\circ 6'} = 12.74 \angle 38^\circ 42' \Omega$$

$$\text{Resistance of the coil } R = 12.74 \cos 38^\circ 42' = 9.94 \Omega$$

$$\text{Reactance of the coil } X = 12.74 \sin 38^\circ 42' = 7.96 \Omega$$

$$\therefore \text{ inductance of the coil } L = \frac{X}{2\pi f} = \frac{7.96}{2 \times \pi \times 50} = 0.0253 \text{ H}$$

The power factor $\cos q$ is varied by rotating the phase shift rotor, the phase angle between voltage and current, F being given by the reading on the dial of the phase shifter. The power is then $VI \cos F$ and the wattmeter reading may be compared with this reading.

A calibration curve may be drawn if necessary. A small mutual inductance M is included to ensure accuracy of measurement of zero power factor.

Example 5.7

The following results were obtained for determination of impedance of a coil by using a coordinate type potentiometer: Voltage across the 1.0Ω resistor in series with the coil = $+0.2404 \text{ V}$ in phase dial and 0.0935 V on quadrature dial Voltage across $10:1$ potential divider used with the coil = $+0.3409 \text{ V}$ on in phase dial and $+0.2343 \text{ V}$ on quadrature dial Calculate the resistance and reactance of the coil.

Solution

Current through the coil

$$\bar{I} = \frac{(+0.2404 - j0.0935)}{1.0} = (+0.2404 - j0.0935) \text{ A}$$

Voltage across the coil

$$\bar{V} = 10(0.3409 + j0.2343) = (3.409 + j2.343) \text{ V}$$

\therefore impedance of the coil

$$\begin{aligned} \bar{Z} &= \frac{\bar{V}}{\bar{I}} = \frac{3.409 + j2.343}{0.2404 - j0.0935} = \frac{4.136 \angle 34.5^\circ}{0.258 \angle -21.2^\circ} = 16.03 \angle 55.7^\circ \\ &= (9.03 + j13.24) \Omega \end{aligned}$$

\therefore resistance of the coil $R = 9.03 \Omega$

Reactance of the coil $L = 13.24 \Omega$

Example 5.9

The following results were obtained during the measurement of power by a polar potentiometer: Voltage across 0.2Ω standard resistor in series with the load = $1.52 \angle -35^\circ$ Voltage across $200:1$ potential divider across the line = $1.43 \angle -53^\circ$ Calculate the current, voltage, power and power factor of the load.

Solution

(a) Current through the load, $\bar{I} = \frac{1.52 \angle -35^\circ}{0.2} = 7.6 \angle -35^\circ \text{ A}$

Magnitude of the current $I = 7.6 \text{ A}$

(b) Voltage across the load $V = 200 \times (1.43 \angle -53^\circ) = 286 \angle -53^\circ \text{ V}$

Magnitude of the voltage $V = 286 \text{ V}$

(c) Phase angle of the load = $53^\circ < 35^\circ = 18^\circ$

\therefore power factor of the load $\cos \phi = \cos 18^\circ = 0.951$ (lagging)

(d) Power consumed by the load, $P = I \cos \phi = 286 \times 0.951$

EXERCISE

Objective-type Questions

- The transfer instrument which is used for standardisation of a polar-type ac potentiometer is
 - an electrostatic instrument
 - a dynamometer instrument
 - a moving coil instrument
 - a thermal instrument
- A dc potentiometer is designed to measure up to about 2 volts with a slide wire of 800 mm. A standard cell of emf 1.18 volt obtains balance at 600 mm. a test cell is seen to obtained balance at 680 mm. The emf of the test cell is
 - 1.50 volts
 - 1.00 volts
 - 1.34 volts
 - 1.70 volts
- For measuring an ac voltage by an ac potentiometer, it is desirable that the supply for the potentiometer is taken from
 - a battery
 - the same source as the unknown voltage
 - a source other than the source of unknown voltage
 - any of the above
- The calibration of a voltmeter can be carried out by using
 - an ammeter
 - a function generator
 - a frequency meter
 - a potentiometer
- A slide wire potentiometer has 10 wires of 1 m each. With the help of a standard voltage source of 1.018 volt it is standardise by keeping the jockey at 101.8 cm. If the resistance of the potentiometer wire is $1000\ \Omega$ then the value of the working current is
 - 1 mA
 - 0.5 mA
 - 0.1 A
 - 10 mA
- In the potentiometer circuit, the value of the unknown voltage E under balance condition will be
 - 3 V
 - 200 mV
 - 2.8 V
 - 3.2 V

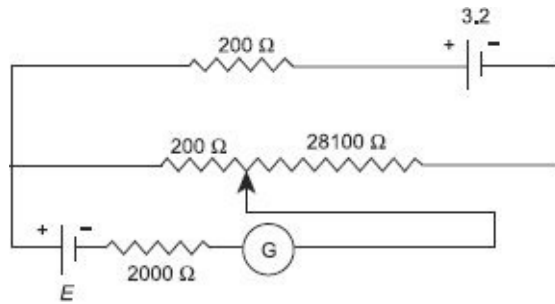

7. The potentiometer is standardised for making it
- precise
 - accurate
 - accurate and precise
 - accurate and direct reading
8. Consider the following statements. A dc potentiometer is the best means available for the measurement of dc voltage because
- The precision in measurement is independent of the type of detector used
 - It is based on null balance technique
 - It is possible to standardize before a measurement is undertaken
 - It is possible to measure dc voltages ranging in value from mV to hundreds of volts
- Of these statements,
- 2 and 3 are correct
 - 1 and 4 are correct
 - 2 and 4 are correct
 - 3 and 4 are correct
9. In a dc potentiometer measurements, a second reading is often taken after reversing the polarities of dc supply and the unknown voltage, and the average of the two readings is taken. This is with a view to eliminate the effects of
- ripples in the dc supply
 - stray magnetic field
 - stray thermal emfs
 - erroneous standardisation

Answers						
1. (d)	2. (c)	3. (b)	4. (d)	5. (d)	6. (b)	7. (d)
8. (c)	9. (c)					

Short-answer Questions

- Explain why a potentiometer does not load the voltage source whose voltage is being measured.
- Describe the procedure of standardisation of a dc potentiometer.
- What is a *volt ratio* box? Explain its principle with a suitable block diagram.
- Explain the reasons why dc potentiometers cannot be used for ac measurement directly.
- Explain the procedure for measurement of self-reactance of a coil with the help of ac potentiometer.
- What is the difference between a slide-wire potentiometer and direct reading potentiometer?
- How can a dc potentiometer be used for calibration of voltmeter?
- Explain with suitable diagram how a dc potentiometer can be used for calibration of an ammeter.
- Explain with a suitable diagram how a dc potentiometer can be used for calibration of wattmeter.
- What are the different forms of ac potentiometers and bring out the differences between them.

Long-answer Questions

1. (a) Explain the working principle of a Crompton dc potentiometer with a suitable diagram.
(b) The emf of a standard cell is measured with a potentiometer which gives a reading of 1.01892 volts. When a $1\text{ M}\Omega$ resistor is connected across the standard cell terminals, the potentiometer reading drops to 1.01874 volts. Calculate the internal resistance of the cell.
[Ans: 176.6 Ω]

2. (a) Name the different types of dc potentiometers and explain one of them.
(b) A slidewire potentiometer is used to measure the voltage between the two points of a certain dc circuit. The potentiometer reading is 1.0 volt. Across the same two points when a $10000\ \Omega/\text{V}$ voltmeter is connected, the reading on the voltmeter is 0.5 volt of its 5-volt range. Calculate the input resistance between two points.
[Ans: 50000 Ω]

3. (a) Write down the procedure of standardisation of a dc potentiometer. How can it be used for calibration of ammeters and voltmeters?
(b) A slidewire potentiometer has a battery of 4 volts and negligible internal resistance. The resistance of slide wire is $100\ \Omega$ and its length is 200 cm. A standard cell of 1.018 volts is used for standardising the potentiometer and the rheostat is adjusted so that balance is obtained when the sliding contact is at 101.8 cm.
 - (i) Find the working current of the slidewire and the rheostat setting.
[Ans: 20 mA, 100 Ω]

 - (ii) If the slidewire has divisions marked in mm and each division can be interpolated to one fifth, calculate the resolution of the potentiometer.
[Ans: 0.2 mV]

4. (a) What are the problems associated with ac potentiometers? Describe the working of any one ac potentiometer.
(b) Power is being measured with an ac potentiometer. The voltage across a $0.1\ \Omega$ standard resistance connected in series with the load is $(0.35 - j0.10)$ volt. The voltage across 300:1 potential divider connected to the supply is $(0.8 + j0.15)$ volt. Determine the power consumed by the load and the power factor.
[Ans: 801 W, 0.8945]

5. (a) Describe the construction and working of an ac coordinate-type potentiometer.
(b) Measurements for the determination of the impedance of a coil are made on a coordinate type potentiometer. The result are: Voltage across $1\ \Omega$ standard resistance in series with the coil = +0.952 V on inphase dial and -0.340 V on quadrature dial; voltage across 10:1 potential divider connected to the terminals of the coil = +1.35 V on inphase dial and +1.28 V on quadrature dial.
Calculate the resistance and reactance of the coil.
[Ans: R = 8.32 Ω , $X = 16.41\ \Omega$]

6. Describe briefly the applications of ac potentiometers.
7. Write short notes on the following (any three):
 - (a) Simple dc potentiometer and its uses
 - (b) Calibration of low range ammeter
 - (c) Measurement of high voltage by dc potentiometer
 - (d) Polar potentiometer
 - (e) Coordinate-type potentiometer
 - (f) Comparison between ac and dc potentiometer

6.1

INTRODUCTION

Alternating current bridges are most popular, convenient and accurate instruments for measurement of unknown inductance, capacitance and some other related quantities. In its simplest form, ac bridges can be thought of to be derived from the conventional dc Wheatstone bridge. An ac bridge, in its basic form, consists of four arms, an alternating power supply, and a balance detector.

6.2

SOURCES AND DETECTORS IN ac BRIDGES

For measurements at low frequencies, bridge power supply can be obtained from the power line itself. Higher frequency requirements for power supplies are normally met by electronic oscillators. Electronic oscillators have highly stable, accurate yet adjustable frequencies. Their output waveforms are very close to sinusoidal and output power level sufficient for most bridge measurements.

When working at a single frequency, a tuned detector is preferred, since it gives maximum sensitivity at the selected frequency and discrimination against harmonic frequencies. *Vibration galvanometers* are most commonly used as tuned detectors in the power frequency and low audio-frequency ranges. Though vibration galvanometers can be designed to work as detectors over the frequency range of 5 Hz to 1000 Hz, they have highest sensitivity when operated for frequencies below 200 Hz.

Head phones or *audio amplifiers* are popularly used as balance detectors in ac bridges at frequencies of 250 Hz and above, up to 3 to 4 kHz.

Transistor amplifier with *frequency tuning* facilities can be very effectively used as balance detectors with ac bridges. With proper tuning, these can be used to operate at a selective band of frequencies with high sensitivity. Such detectors can be designed to operate over a frequency range of 10 Hz to 100 kHz.

6.3

GENERAL BALANCE EQUATION FOR FOUR-ARM BRIDGE

An ac bridge in its general form is shown in [Figure 6.1](#), with the four arms being represented by four unspecified impedances Z_1 , Z_2 , Z_3 and Z_4 .

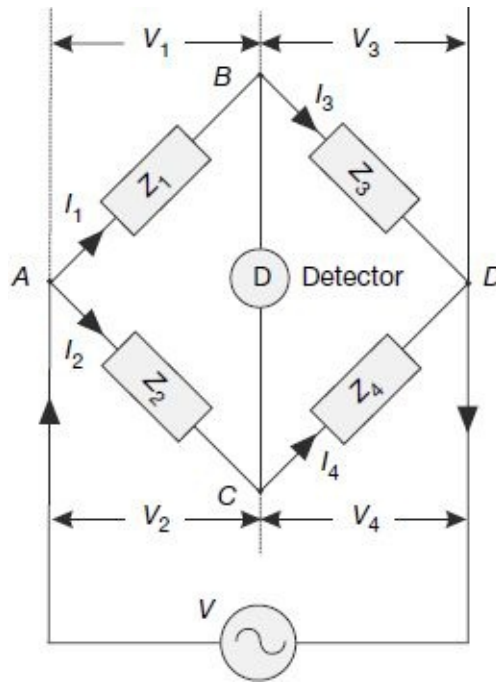

Figure 6.1 General 4-arm bridge configuration

Balance in the bridge is secured by adjusting one or more of the bridge arms. Balance is indicated by zero response of the detector. At balance, no current flows through the detector, i.e., there is no potential difference across the detector, or in other words, the potentials at points B and C are the same. This will be achieved if the voltage drop from A to B equals the voltage drop from A to C, both in magnitude and phase.

Thus, we can write in terms of complex quantities:

$$\bar{V}_1 = \bar{V}_2$$

or,
$$\bar{I}_1 \bar{Z}_1 = \bar{I}_2 \bar{Z}_2 \tag{6.1}$$

Also at balance, since no current flows through the detector,

$$\bar{I}_1 = \bar{I}_3 = \frac{\bar{V}}{\bar{Z}_1 + \bar{Z}_3} \tag{6.2}$$

and
$$\bar{I}_2 = \bar{I}_4 = \frac{\bar{V}}{\bar{Z}_2 + \bar{Z}_4} \tag{6.3}$$

Combining Eqs (6.2) and (6.3) into Eq. (6.1), we have

$$\frac{\bar{V}}{\bar{Z}_1 + \bar{Z}_3} \bar{Z}_1 = \frac{\bar{V}}{\bar{Z}_2 + \bar{Z}_4} \bar{Z}_2$$

or,
$$\bar{Z}_1 \bar{Z}_2 + \bar{Z}_1 \bar{Z}_4 = \bar{Z}_2 \bar{Z}_1 + \bar{Z}_2 \bar{Z}_3$$

or,
$$\bar{Z}_1 \bar{Z}_4 = \bar{Z}_2 \bar{Z}_3 \tag{6.4}$$

or,
$$\frac{\bar{Z}_1}{\bar{Z}_3} = \frac{\bar{Z}_2}{\bar{Z}_4} \tag{6.5}$$

When using admittances in place of impedances, Eq. (6.4) can be re-oriented as

$$\bar{Y}_1 \bar{Y}_4 = \bar{Y}_2 \bar{Y}_3 \tag{6.6}$$

Equations (6.4) and (6.6) represent the basic balance equations of an ac bridge. Whereas (6.4) is convenient for use in bridge configurations having series elements, (6.6) is more

useful when bridge configurations have parallel elements.

Equation (6.4) indicates that under balanced condition, the product of impedances of one pair of *opposite* arms must be equal to the product of impedances of the other pair of *opposite* arms, with the impedances expressed as complex numbers. This will mean, both magnitude and phase angles of the complex numbers must be taken into account.

Re-writing the expressions in polar form, impedances can be expressed as $\bar{Z} = Z\angle\theta$ where Z represents the magnitude and θ represents the phase angle of the complex impedance.

If similar forms are written for all impedances and substituted in (6.4), we obtain:

$$Z_1\angle\theta_1 \times Z_4\angle\theta_4 = Z_2\angle\theta_2 \times Z_3\angle\theta_3$$

Thus, for balance we have,

$$Z_1Z_4\angle(\theta_1 + \theta_4) = Z_2Z_3\angle(\theta_2 + \theta_3) \quad (6.7)$$

Equation (6.7) shows that two requirements must be met for satisfying balance condition in a bridge.

The first condition is that the magnitude of the impedances must meet the relationship;
 $Z_1Z_4 = Z_2Z_3$ (6.8)

The second condition is that the phase angles of the impedances must meet the relationship; $\angle(\theta_1 + \theta_4) = \angle(\theta_2 + \theta_3)$ (6.9)

Example 6.1

In the AC bridge circuit shown in Figure 6.1, the supply voltage is 20 V at 500 Hz. Arm AB is 0.25 mμ pure capacitance; arm BD is 400 Ω pure resistance and arm AC has a 120 Ω resistance in parallel with a 0.15 mμ capacitor. Find resistance and inductance or capacitance of the arm CD considering it as a series circuit.

Solution Impedance of the arm AB is

$$Z_1 = \frac{1}{2\pi fC_1} = \frac{1}{2\pi \times 500 \times 0.25 \times 10^{-6}} = 1273 \Omega$$

Since it is purely capacitive, in complex notation, $\bar{Z}_1 = 1273\angle -90^\circ \Omega$

Impedance of arm *BD* is $Z_3 = 400 \Omega$

Since it is purely resistive, in complex notation, $\bar{Z}_3 = 400\angle 0^\circ \Omega$

Impedance of arm AC containing 120 Ω resistance in parallel with a 0.15 μF capacitor is

$$\bar{Z}_2 = \frac{R_2}{1 + j2\pi fC_2R_2} = \frac{120}{1 + j(2\pi \times 500 \times 0.15 \times 10^{-6} \times 120)}$$

$$= 119.8 \angle -3.2^\circ \Omega$$

For balance, $\bar{Z}_1\bar{Z}_4 = \bar{Z}_2\bar{Z}_3$

\therefore impedance of arm CD required for balance is $\bar{Z}_4 = \frac{\bar{Z}_2\bar{Z}_3}{\bar{Z}_1}$

or,
$$\bar{Z}_4 = \frac{119.88 \times 400}{1273} \angle (-3.2^\circ + 0^\circ + 90^\circ) = 37.65 \angle 86.8^\circ$$

The positive angle of impedance indicates that the branch consists of a series combination of resistance and inductance.

Resistance of the unknown branch $R_4 = 37.65 \times \cos(86.8^\circ) = 2.1 \Omega$

Inductive reactance of the unknown branch

$$X_4 = 37.65 \times \sin(86.8^\circ) = 37.59 \Omega$$

Inductance of the unknown branch $L_4 = \frac{37.59}{2\pi \times 500} H = 11.97 \text{ mH}$

6.4

MEASUREMENT OF SELF-INDUCTANCE

6.4.1 Maxwell's Inductance Bridge

This bridge is used to measure the value of an unknown inductance by comparing it with a variable standard self-inductance. The bridge configuration and phasor diagram under balanced condition are shown in [Figure 6.2](#).

The unknown inductor L_1 of resistance R_1 in the branch AB is compared with the standard known inductor L_2 of resistance R_2 on arm AC . The inductor L_2 is of the same order as the unknown inductor L_1 . The resistances R_1 , R_2 , etc., include, of course the resistances of contacts and leads in various arms. Branch BD and CD contain known non-inductive resistors R_3 and R_4 respectively.

The bridge is balanced by varying L_2 and one of the resistors R_3 or R_4 . Alternatively, R_3 and R_4 can be kept constant, and the resistance of one of the other two arms can be varied by connecting an additional resistor.

Under balanced condition, no current flows through the detector. Under such condition, currents in the arms AB and BD are equal (I_1). Similarly, currents in the arms AC and CD are equal (I_2). Under balanced condition, since nodes B and D are at the same potential, voltage drops across arm BD and CD are equal ($V_3 = V_4$); similarly, voltage drop across arms AB and AC are equal ($V_1 = V_2$).

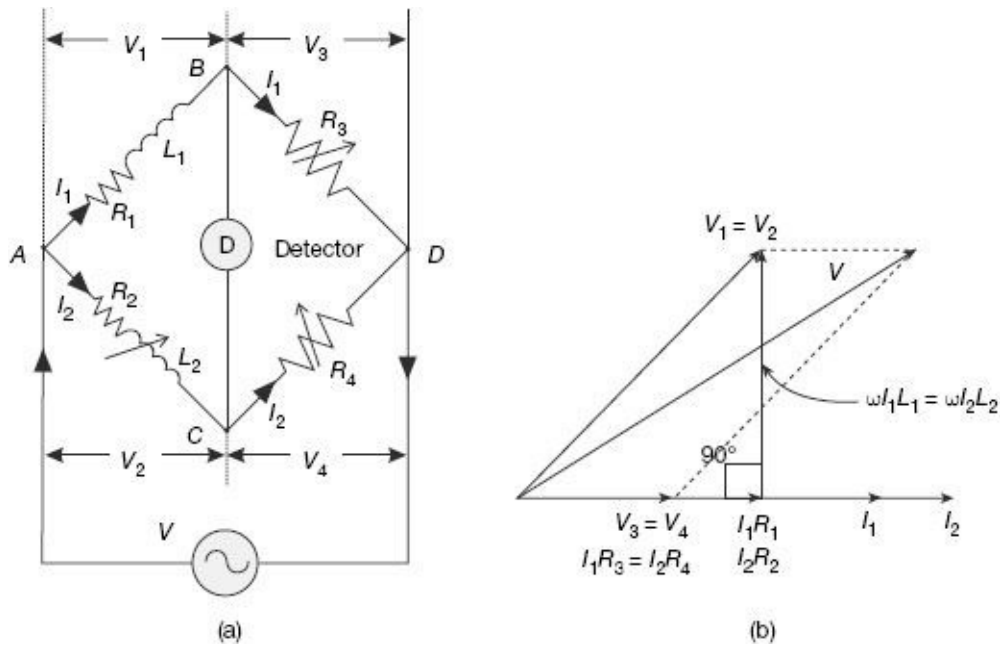

Figure 6.2 Maxwell's inductance bridge under balanced condition: (a) Configuration (b) Phasor diagram

As shown in the phasor diagram of Figure 6.2 (b), V_3 and V_4 being equal, they are overlapping. Arms BD and CD being purely resistive, currents through these arms will be in the same phase with the voltage drops across these two respective branches. Thus, currents I_1 and I_2 will be collinear with the phasors V_3 and V_4 . The same current I_1 flows through branch AB as well, thus the voltage drop I_1R_1 remains in the same phase as I_1 . Voltage drop ωI_1L_1 in the inductor L_1 will be 90° out of phase with I_1R_1 as shown in Figure 6.2(b). Phasor summation of these two voltage drops I_1R_1 and ωI_1L_1 will give the voltage drop V_1 across the arm AB . At balance condition, since voltage across the two branches AB and AC are equal, thus the two voltage drops V_1 and V_2 are equal and are in the same phase. Finally, phasor summation of V_1 and V_3 (or V_2 and V_4) results in the supply voltage V .

$$\text{At balance, } \frac{R_1 + j\omega L_1}{R_3} = \frac{R_2 + j\omega L_2}{R_4}$$

$$\text{or, } R_1R_4 + j\omega L_1R_4 = R_2R_3 + j\omega L_2R_3$$

Equating real and imaginary parts, we have

$$R_1R_4 = R_2R_3$$

$$\text{or, } \frac{R_1}{R_2} = \frac{R_3}{R_4}$$

$$\text{and also, } j\omega L_1R_4 = j\omega L_2R_3$$

$$\text{or, } \frac{L_1}{L_2} = \frac{R_3}{R_4}$$

$$\text{Thus, } \frac{R_1}{R_2} = \frac{R_3}{R_4} = \frac{L_1}{L_2}$$

Unknown quantities can hence be calculated as

$$L_1 = L_2 \times \frac{R_3}{R_4} \text{ and } R_1 = R_2 \times \frac{R_3}{R_4} \quad (6.10)$$

Care must be taken that the inductors L_1 and L_2 must be placed at a distance from each

other to avoid effects of mutual inductance.

The final expression (6.10) shows that values of L_1 and R_1 do not depend on the supply frequency. Thus, this bridge configuration is immune to frequency variations and even harmonic distortions in the power supply.

6.4.2 Maxwell's Inductance–Capacitance Bridge

In this bridge, the unknown inductance is measured by comparison with a standard variable capacitance. It is much easier to obtain standard values of variable capacitors with acceptable degree of accuracy. This is however, not the case with finding accurate and stable standard value variable inductor as is required in the basic Maxwell's bridge described in Section 6.4.1.

Configuration of a Maxwell's inductance–capacitance bridge and the associated phasor diagram at balanced state are shown in Figure 6.3.

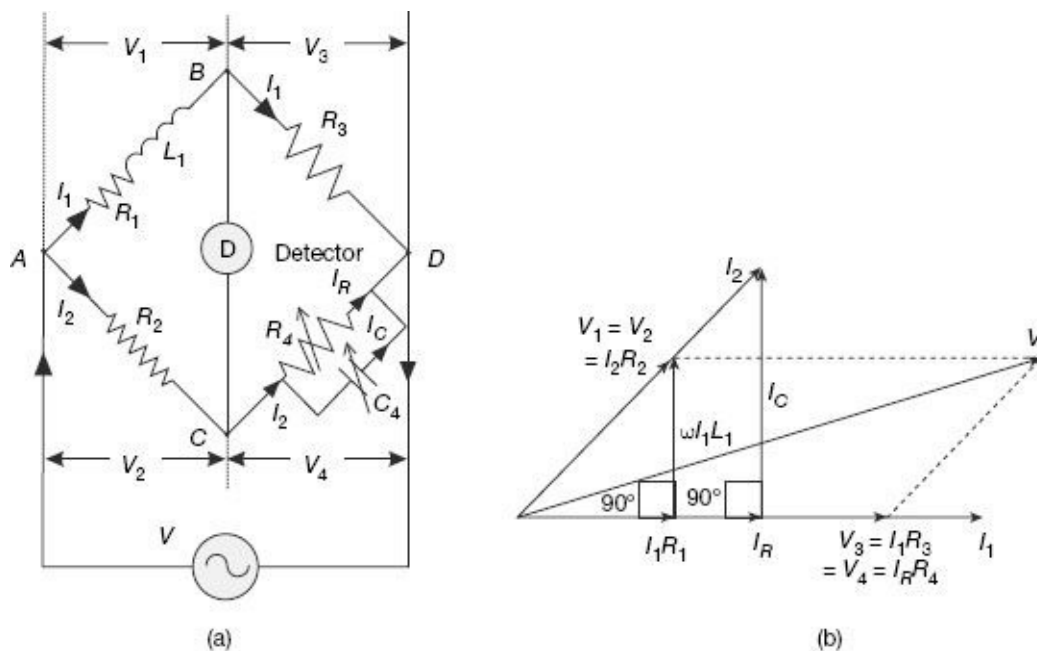

Figure 6.3 Maxwell's inductance–capacitance bridge under balanced condition: (a) Configuration (b) Phasor diagram

The unknown inductor L_1 of effective resistance R_1 in the branch AB is compared with the standard known variable capacitor C_4 on arm CD . The other resistances R_2 , R_3 , and R_4 are known as non-inductive resistors.

The bridge is preferably balanced by varying C_4 and R_4 , giving independent adjustment settings.

Under balanced condition, no current flows through the detector. Under such condition, currents in the arms AB and BD are equal (I_1). Similarly, currents in the arms AC and CD are equal (I_2). Under balanced condition, since nodes B and D are at the same potential, voltage drops across arm BD and CD are equal ($V_3 = V_4$); similarly, voltage drops across arms AB and AC are equal ($V_1 = V_2$).

As shown in the phasor diagram of Figure 6.3 (b), V_3 and V_4 being equal, they are overlapping both in magnitude and phase. The arm BD being purely resistive, current I_1

through this arm will be in the same phase with the voltage drop V_3 across it. Similarly, the voltage drop V_4 across the arm CD , current I_R through the resistance R_4 in the same branch, and the resulting resistive voltage drop $I_R R_4$ are all in the same phase [horizontal line in Figure 6.3(b)]. The resistive current I_R when added with the quadrature capacitive current I_C , results in the main current I_2 flowing in the arm CD . This current I_2 while flowing through the resistance R_2 in the arm AC , produces a voltage drop $V_2 = I_2 R_2$, that is in same phase as I_2 . Under balanced condition, voltage drops across arms AB and AC are equal, i.e., $V_1 = V_2$. This voltage drop across the arm AB is actually the phasor summation of voltage drop $I_1 R_1$ across the resistance R_1 and the quadrature voltage drop $\omega L_1 I_1$ across the unknown inductor L_1 . Finally, phasor summation of V_1 and V_3 (or V_2 and V_4) results in the supply voltage V .

$$\text{At balance, } \frac{R_1 + j\omega L_1}{R_3} = \frac{R_2}{\left(\frac{R_4}{1 + j\omega C_4 R_4} \right)}$$

$$\text{or, } R_1 R_4 + j\omega L_1 R_4 = R_2 R_3 + j\omega C_4 R_2 R_3 R_4$$

Equating real and imaginary parts, we have

$$R_1 R_4 = R_2 R_3$$

$$\text{or, } R_1 = R_2 \times \frac{R_3}{R_4}$$

$$\text{and also, } j\omega L_1 R_4 = j\omega C_4 R_2 R_3 R_4$$

$$\text{or, } L_1 = C_4 R_2 R_3$$

Thus, the unknown quantities are

$$L_1 = C_4 R_2 R_3 \text{ and } R_1 = R_2 \times \frac{R_3}{R_4} \quad (6.11)$$

Once again, the final expression (6.11) shows that values of L_1 and R_1 do not depend on the supply frequency. Thus, this bridge configuration is immune to frequency variations and even harmonic distortions in the power supply.

It is interesting to note that both in the Maxwell's Inductance Bridge and Inductance-Capacitance Bridge, the unknown Inductor L_1 was always associated with a resistance R_1 . This series resistance has been included to represent losses that take place in an inductor coil. An ideal inductor will be lossless irrespective of the amount of current flowing through it. However, any real inductor will have some non-zero resistance associated with it due to resistance of the metal wire used to form the inductor winding. This series resistance causes heat generation due to power loss. In such cases, the Quality Factor or the Q -Factor of such a lossy inductor is used to indicate how closely the real inductor comes to behave as an ideal inductor. The Q -factor of an inductor is defined as the ratio of its inductive reactance to its resistance at a given frequency. Q -factor is a measure of the efficiency of the inductor. The higher the value of Q -factor, the closer it approaches the behavior of an ideal, loss less inductor. An ideal inductor would have an infinite Q at all frequencies.

The Q-factor of an inductor is given by the formula $Q = \frac{\omega L}{R}$, where R is its internal resistance R (series resistance) and ωL is its inductive reactance at the frequency ω .

Q-factor of an inductor can be increased by either increasing its inductance value (by using a good ferromagnetic core) or by reducing its winding resistance (by using good quality conductor material, in special cases may be super conductors as well).

In the Maxwell's Inductance-Capacitance Bridge, Q-factor of the inductor under measurement can be found at balance condition to be $Q = \frac{\omega L_1}{R_1}$ or,

$$Q = \frac{\omega C_4 R_2 R_3}{R_2 \times \frac{R_3}{R_4}} = \omega C_4 R_4 \quad (6.12)$$

The above relation (6.12) for the inductor Q factor indicate that this bridge is not suitable for measurement of inductor values with high Q factors, since in that case, the required value of R_4 for achieving balance becomes impracticably high.

Advantages of Maxwell's Bridge

1. The balance equations (6.11) are independent of each other, thus the two variables C_4 and R_4 can be varied independently.
2. Final balance equations are independent of frequency.
3. The unknown quantities can be denoted by simple expressions involving known quantities.
4. Balance equation is independent of losses associated with the inductor.
5. A wide range of inductance at power and audio frequencies can be measured.

Disadvantages of Maxwell's Bridge

1. The bridge, for its operation, requires a standard variable capacitor, which can be very expensive if high accuracies are asked for. In such a case, fixed value capacitors are used and balance is achieved by varying R_4 and R_2 .
2. This bridge is limited to measurement of low Q inductors ($1 < Q < 10$).
3. Maxwell's bridge is also unsuited for coils with very low value of Q (e.g., $Q < 1$). Such low Q inductors can be found in inductive resistors and RF coils. Maxwell's bridge finds difficult and laborious to obtain balance while measuring such low Q inductors.

6.4.3 Hay's Bridge

Hay's bridge is a modification of Maxwell's bridge. This method of measurement is particularly suited for high Q inductors.

Configuration of Hay's bridge and the associated phasor diagram under balanced state are shown in [Figure 6.4](#).

The unknown inductor L_1 of effective resistance R_1 in the branch AB is compared with

the standard known variable capacitor C_4 on arm CD . This bridge uses a resistance R_4 in series with the standard capacitor C_4 (unlike in Maxwell's bridge where R_4 was in parallel with C_4). The other resistances R_2 and R_3 are known no-inductive resistors.

The bridge is balanced by varying C_4 and R_4 .

Under balanced condition, since no current flows through the detector, nodes B and D are at the same potential, voltage drops across arm BD and CD are equal ($V_3 = V_4$); similarly, voltage drops across arms AB and AC are equal ($V_1 = V_2$).

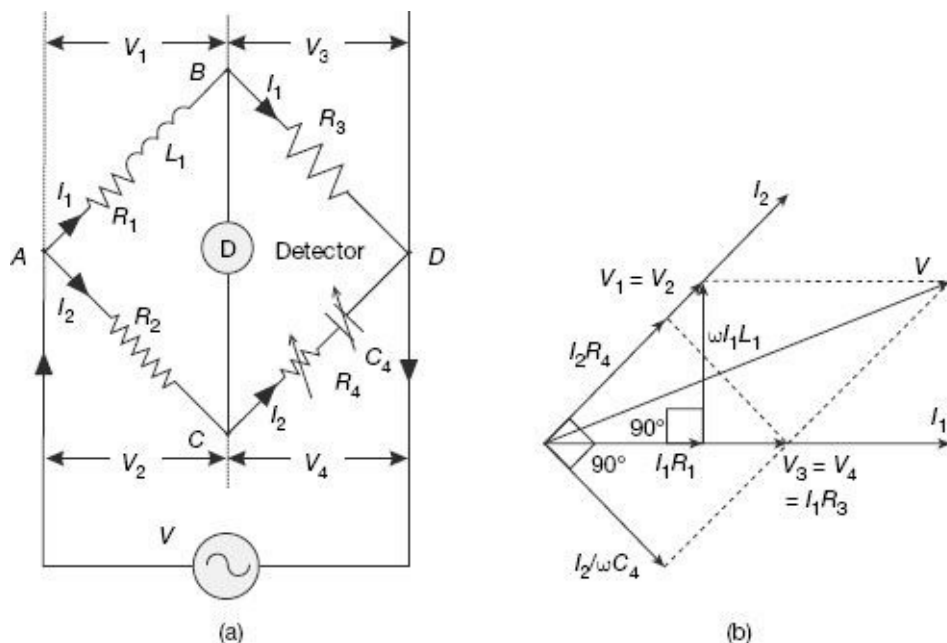

Figure 6.4 Hay's bridge under balanced condition: (a) Configuration, (b) Phasor diagram

As shown in the phasor diagram of [Figure 6.4 \(b\)](#), V_3 and V_4 being equal, they are overlapping both in magnitude and phase and are drawn along the horizontal axis. The arm BD being purely resistive, current I_1 through this arm will be in the same phase with the voltage drop $V_3 = I_1R_3$ across it. The same current I_1 , while passing through the resistance R_1 in the arm AB , produces a voltage drop I_1R_1 that is once again, in the same phase as I_1 . Total voltage drop V_1 across the arm AB is obtained by adding the two quadrature phasors I_1R_1 and ωI_1L_1 representing resistive and inductive voltage drops in the same branch AB . Since under balance condition, voltage drops across arms AB and AC are equal, i.e., ($V_1 = V_2$), the two voltages V_1 and V_2 are overlapping both in magnitude and phase. The branch AC being purely resistive, the branch current I_2 and branch voltage V_2 will be in the same phase as shown in the phasor diagram of [Figure 6.4 \(b\)](#). The same current I_2 flows through the arm CD and produces a voltage drop I_2R_4 across the resistance R_4 . This resistive voltage drop I_2R_4 , obviously is in the same phase as I_2 . The capacitive voltage drop $I_2/\omega C_4$ in the capacitance C_4 present in the same arm AC will however, lag the current I_2 by 90° . Phasor summation of these two series voltage drops across R_4 and C_4 will give the total voltage drop V_4 across the arm CD . Finally, phasor summation of V_1 and V_3 (or V_2 and V_4) results in the supply voltage V .

At balance,

$$\frac{R_1 + j\omega L_1}{R_3} = \frac{R_2}{\left(R_4 - \frac{j}{\omega C_4}\right)}$$

or,

$$R_1 R_4 + \frac{L_1}{C_4} + j\omega L_1 R_4 - \frac{jR_1}{\omega C_4} = R_2 R_3$$

Equating real and imaginary parts, we have

Equating real and imaginary parts, we have

$$R_1 R_4 + \frac{L_1}{C_4} = R_2 R_3 \quad (6.13)$$

and

$$\omega L_1 R_4 = \frac{R_1}{\omega C_4} \quad (6.14)$$

Solving Eqs (6.13) and (6.14) we have the unknown quantities as

$$L_1 = \frac{R_2 R_3 C_4}{1 + \omega^2 R_4^2 C_4^2} \quad (6.15)$$

and

$$R_1 = \frac{R_2 R_3 R_4 \omega^2 C_4^2}{1 + \omega^2 R_4^2 C_4^2} \quad (6.16)$$

Q factor of the inductor in this case can be calculated at balance condition as

$$Q = \frac{\omega L_1}{R_1} = \frac{1}{\omega C_4 R_4} \quad (6.17)$$

Hay's bridge is more suitable for measurement of unknown inductors having Q factor more than 10. In those cases, bridge balance can be attained by varying R_2 only, without losing much accuracy.

From (6.15) and (6.17), the unknown inductance value can be written as

$$L_1 = \frac{R_2 R_3 C_4}{1 + (1/Q)^2} \quad (6.18) \text{ For inductors with}$$

$Q > 10$, the quantity $(1/Q)^2$ will be less than $1/100$, and thus can be neglected from the denominator of (6.18). In such a case, the inductor value can be simplified to $L_1 = R_2 R_3 C_4$, which essentially is the same as obtained in Maxwell's bridge.

6.4.4 Anderson's Bridge

This method is a modification of Maxwell's inductance–capacitance bridge, in which value of the unknown inductor is expressed in terms of a standard known capacitor. This method is applicable for precise measurement of inductances over a wide range of values.

Figure 6.5 shows Anderson's bridge configuration and corresponding phasor diagram under balanced condition.

The unknown inductor L_1 of effective resistance R_1 in the branch AB is compared with the standard known capacitor C on arm ED . The bridge is balanced by varying r .

Under balanced condition, since no current flows through the detector, nodes B and E are at the same potential.

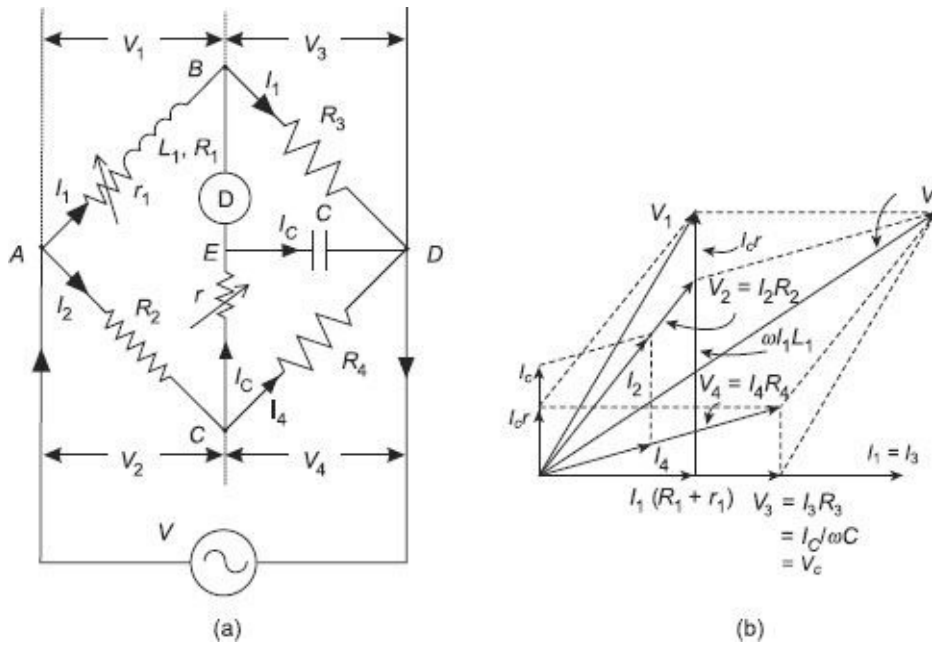

Figure 6.5 Anderson's bridge under balanced condition: (a) Configuration (b) Phasor diagram

As shown in the phasor diagram of Figure 6.5 (b), I_1 and $V_3 = I_1 R_3$ are in the same phase along the horizontal axis. Since under balance condition, voltage drops across arms BD and ED are equal, $V_3 = I_1 R_3 = I_C / \omega C$ and all the three phasors are in the same phase. The same current I_1 , when flowing through the arm AB produces a voltage drop $I_1(R_1 + r_1)$ which is once again, in phase with I_1 . Since under balanced condition, no current flows through the detector, the same current I_C flows through the resistance r in arm CE and then through the capacitor C in the arm ED . Phasor summation of the voltage drops $I_C r$ in arm the CE and $I_C / \omega C$ in the arm ED will be equal to the voltage drop V_4 across the arm CD . V_4 being the voltage drop in the resistance R_4 on the arm CD , the current I_4 and V_4 will be in the same phase. As can be seen from the Anderson's bridge circuit, and also plotted in the phasor diagram, phasor summation of the currents I_4 in the arm CD and the current I_C in the arm CE will give rise to the current I_2 in the arm AC . This current I_2 , while passing through the resistance R_2 will give rise to a voltage drop $V_2 = I_2 R_2$ across the arm AC that is in phase with the current I_2 . Since, under balance, potentials at nodes B and E are the same, voltage drops between nodes $A - B$ and between $A - C - E$ will be equal. Thus, phasor summation of the voltage drop $V_2 = I_2 R_2$ in the arm AC $I_C r$ in arm the CE will build up to the voltage V_1 across the arm AB . The voltage V_1 can also be obtained by adding the resistive voltage drop $I_1(R_1 + r_1)$ with the quadrature inductive voltage drop $\omega I_1 L_1$ in the arm AB . Finally, phasor summation of V_1 and V_3 (or V_2 and V_4) results in the supply voltage V .

$$\text{At balance, } I_2 = I_C + I_4$$

$$\text{and, } V_{BD} = V_{ED}, \text{ or } I_1 R_3 = I_C \times \frac{1}{j\omega C}$$

$$\therefore I_C = j\omega I_1 R_3 C \quad (6.19)$$

The other balance equations are:

$$V_{AB} = V_{AC} + V_{CE}, \text{ or } I_1(r_1 + R_1 + j\omega L_1) = I_2 R_2 + I_C r \quad (6.20)$$

$$\text{and, } V_{CD} = V_{CE} + V_{ED}, \text{ or } I_C \left(r + \frac{1}{j\omega C} \right) = (I_2 - I_C)R_4 \quad (6.21)$$

Putting the value of I_C from Eq. (6.19) in Eq. (6.20), we have: $I_1 r (+R + j\omega L) = IR + j\omega I R C r$

$$I_1 (r_1 + R_1 + j\omega L_1) = I_2 R_2 + j\omega I_1 R_3 C r$$

$$\text{or, } I_1 (r_1 + R_1 + j\omega L_1 - j\omega R_3 C r) = I_2 R_2 \quad (6.22)$$

Then, putting the value of I_C from Eq. (6.19) in Eq. (6.21), we have: $\hat{E}1 \wedge$

$$j\omega I_1 R_3 C \left(r + \frac{1}{j\omega C} \right) = (I_2 - j\omega I_1 R_3 C) R_4$$

$$\text{or, } I_1 (j\omega R_3 C r + R_3 + j\omega R_3 C R_4) = I_2 R_4 \quad (6.23)$$

From Eqs (6.22) and (6.23), we obtain:

From Eqs (6.22) and (6.23), we obtain:

$$I_1 (r_1 + R_1 + j\omega L_1 - j\omega R_3 C r) = I_1 (j\omega R_3 C r + R_3 + j\omega R_3 C R_4) \frac{R_2}{R_4}$$

Equating real and imaginary parts, we get

$$R_1 = \frac{R_2 R_3}{R_4} - r_1 \quad (6.24)$$

$$\text{and, } L_1 = C \frac{R_3}{R_4} [r(R_2 + R_4) + R_2 R_4] \quad (6.25)$$

The advantage of Anderson's bridge over Maxwell's bride is that in this case a fixed value capacitor is used thereby greatly reducing the cost. This however, is at the expense of connection complexities and balance equations becoming tedious.

6.4.5 Owen's Bridge

This bridge is used for measurement of unknown inductance in terms of known value capacitance.

Figure 6.6 shows the Owen's bridge configuration and corresponding phasor diagram under balanced condition.

The unknown inductor L_1 of effective resistance R_1 in the branch AB is compared with the standard known capacitor C_2 on arm AC . The bridge is balanced by varying R_2 and C_2 independently.

Under balanced condition, since no current flows through the detector, nodes B and C are at the same potential, i.e., $V_1 = V_2$ and $V_3 = V_4$.

As shown in the phasor diagram of Figure 6.5 (b), I_1 , $V_3 = I_1 R_3$ and $V_4 = I_2 / \omega C_4$ are all in the same phase along the horizontal axis. The resistive voltage drop $I_1 R_1$ in the arm AB is also in the same phase

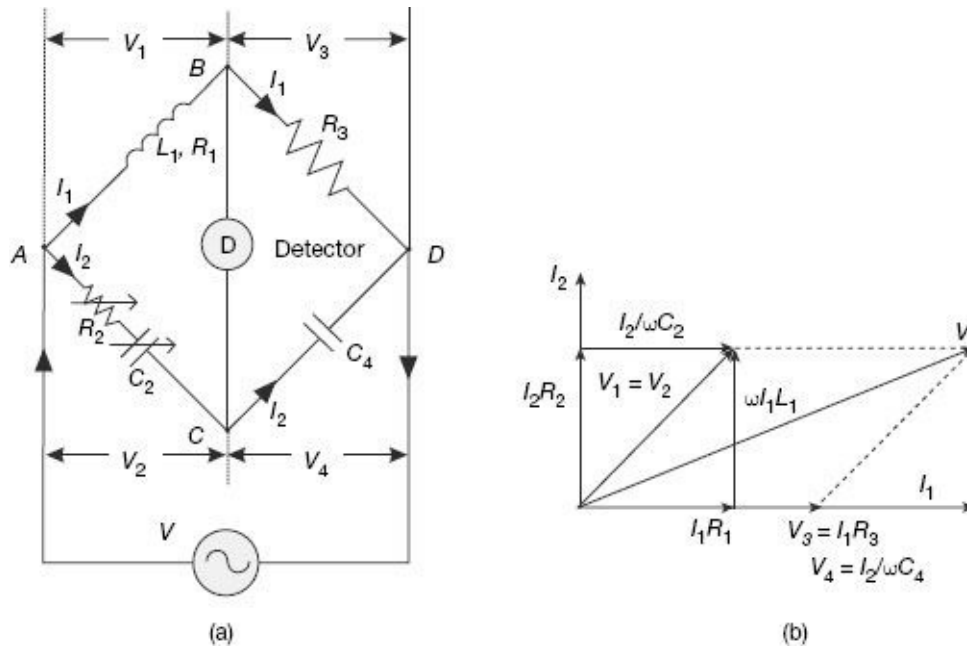

Figure 6.6 Owen's bridge under balanced condition: (a) Configuration (b) Phasor diagram

with I_1 . The inductive voltage drop $\omega I_1 L_1$ when added in quadrature with the resistive voltage drop $I_1 R_1$ gives the total voltage drop V_1 across the arm AB . Under balance condition, voltage drops across arms AB and AC being equal, the voltages V_1 and V_2 coincide with each other as shown in the phasor diagram of Figure 6.6 (b). The voltage V_2 is once again summation of two mutually quadrature voltage drops $I_2 R_2$ (resistive) and $I_2/\omega C_2$ (capacitive) in the arm AC . It is to be noted here that the current I_2 leads the voltage V_4 by 90° due to presence of the capacitor C_4 . This makes I_2 and hence $I_2 R_2$ to be vertical, as shown in the phasor diagram. Finally, phasor summation of V_1 and V_3 (or V_2 and V_4) results in the supply voltage V .

$$\text{At balance, } \frac{(R_1 + j\omega L_1)}{R_3} = \frac{\left(R_2 + \frac{1}{j\omega C_2}\right)}{\frac{1}{j\omega C_4}}$$

Simplifying and separating real and imaginary parts, the unknown quantities can be found out as

$$R_1 = R_3 \frac{C_4}{C_2} \quad (6.26)$$

and

$$L_1 = R_2 R_3 C_4 \quad (6.27)$$

It is thus possible to have two independent variables C_2 and R_2 for obtaining balance in Owen's bridge. The balance equations are also quite simple. This however, does come with additional cost for the variable capacitor

Example 6.2

A Maxwell's inductance–capacitance bridge is used to measure a unknown inductive impedance. The bridge constants at bridge balance are: Pure resistance arms = 2.5

$k\Omega$ and $50 k\Omega$. In between these two resistors, the third arm has a capacitor of value $0.012 \mu F$ in series with a resistor of value $235 k\Omega$. Find the series equivalent of the unknown impedance.

Solution Referring to the diagram of a Maxwell's inductance–capacitance bridge:

Using the balance equation,

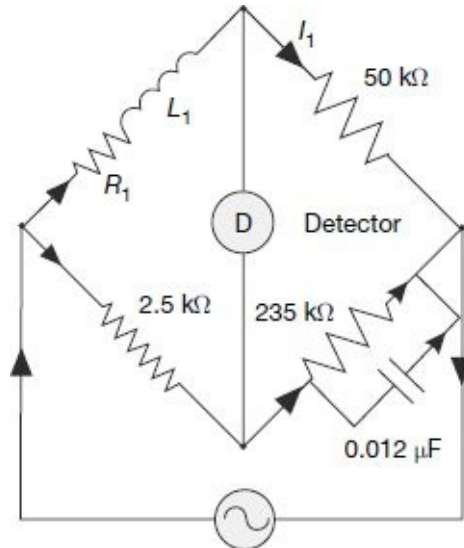

$$L_1 = C_4 R_2 R_3 = 0.012 \times 10^{-6} \times 2.5 \times 10^3 \times 50 \times 10^3 = 1.5 \text{ H}$$

$$\text{and } R_1 = R_2 \times \frac{R_3}{R_4} = 2.5 \times 10^3 \times \frac{50 \times 10^3}{235 \times 10^3} = 0.53 \text{ k}\Omega$$

Example 6.3

The four arms of a bridge are connected as follows:

Arm AB: A choke coil L_1 with an equivalent series resistance r_1

Arm BC: A noninductive resistance R_3

Arm CD: A mica capacitor C_4 in series a noninductive resistance R_4

Arm DA: A noninductive resistance R_2

When the bridge is supplied from a source of 450 Hz is given between terminals A and C and the detector is connected between nodes B and D, balance is obtained the following conditions: $R_2 = 2400 \Omega$, $R_3 = 600 \Omega$, $C_4 = 0.3 \mu F$ and $R_4 = 55.4 \Omega$. Series resistance of the capacitor is 0.5Ω . Calculate the resistance and inductance of the choke coil.

Solution The bridge configuration is shown below:

Given that at balance,

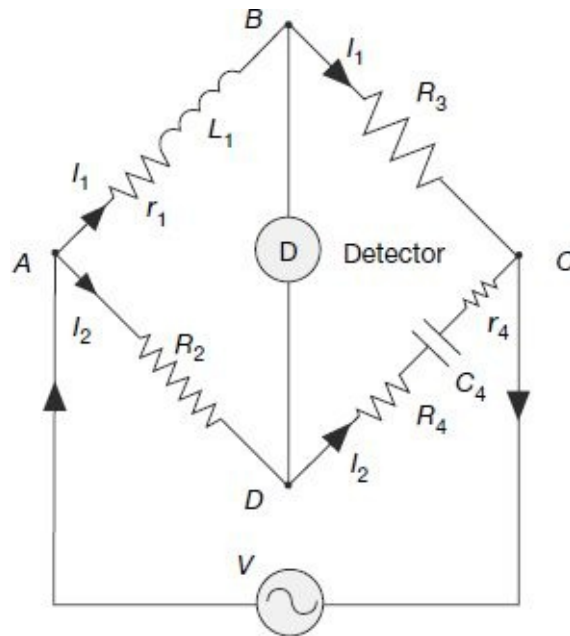

$R_2 = 2400 \Omega$, $R_3 = 600 \Omega$, $C_4 = 0.3 \mu\text{F}$, $R_4 = 55.4 \Omega$ and $r_4 = 0.5 \Omega$.

$$\text{At balance, } \frac{r_1 + j\omega L_1}{R_3} = \frac{R_2}{r_4 + R_4 - \frac{j}{\omega C_4}}$$

or,

$$r_1 r_4 + r_1 R_4 + \frac{L_1}{C_4} + j\omega L_1 R_4 + j\omega L_1 r_4 - \frac{j r_1}{\omega C_4} = R_2 R_3$$

Equating real and imaginary parts, we have

$$r_1 r_4 + r_1 R_4 + \frac{L_1}{C_4} = R_2 R_3 \quad \text{(i)}$$

$$\text{and } \omega L_1 R_4 + \omega L_1 r_4 = \frac{r_1}{\omega C_4} \quad \text{(ii)}$$

Solving (i) and (ii), we have the unknown quantities as

$$L_1 = \frac{R_2 R_3 C_4}{1 + \omega(R_4 + r_4)^2 C_4^2} = \frac{2400 \times 600 \times 0.3 \times 10^{-6}}{1 + (2\pi \times 450 \times 55.9 \times 0.3 \times 10^{-6})^2} = 0.43 \text{ H}$$

and

$$r_1 = \frac{R_2 R_3 (R_4 + r_4) \omega^2 C_4^2}{1 + \omega(R_4 + r_4)^2 C_4^2} = \frac{2400 \times 600 \times 55.9 \times (2\pi \times 450)^2 \times (0.3 \times 10^{-6})^2}{1 + (2\pi \times 450 \times 55.9 \times 0.3 \times 10^{-6})^2} = 57.8 \Omega$$

6.5

MEASUREMENT OF CAPACITANCE

Bridges are used to make precise measurements of unknown capacitances and associated losses in terms of some known external capacitances and resistances. An ideal capacitor is formed by placing a piece of dielectric material between two conducting plates or electrodes. In practical cases, this dielectric material will have some power losses in it due to dielectric's conduction electrons and also due to dipole relaxation phenomena. Thus, whereas an ideal capacitor will not have any losses, a real capacitor will have some losses associated with its operation. The potential energy across a capacitor is thus dissipated in all real capacitors as heat loss inside its dielectric material. This loss is equivalently

represented by a series resistance, called the equivalent series resistance (ESR). In a good capacitor, the ESR is very small, whereas in a poor capacitor the ESR is large. C_{real} C_{ideal} ESR

A real, lossy capacitor can thus be equivalently represented by an ideal lossless capacitor in series with its equivalent series resistance (ESR) shown [Figure 6.7](#) *Equivalent series resistance (ESR)* in [Figure 6.7](#).

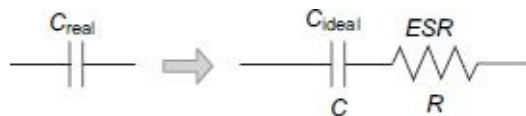

Figure 6.7 *Equivalent series resistance (ESR)*

The quantifying parameters often used to describe performance of a capacitor are ESR, its dissipation factor (DF), Quality Factor (Q-factor) and Loss Tangent ($\tan d$). Not only that these parameters describe operation of the capacitor in radio frequency (RF) applications, but ESR and DF are also particularly important for capacitors operating in power supplies where a large dissipation factor will result in large amount of power being wasted in the capacitor. Capacitors with high values of ESR will need to dissipate large amount of heat. Proper circuit design needs to be practiced so as to take care of such possibilities of heat generation.

Dissipation factor due to the non-ideal capacitor is defined as the ratio of the resistive power loss in the ESR to the reactive power oscillating in the capacitor, or

$$DF = \frac{i^2 R}{i^2 X_C} = \frac{R}{1/\omega C} = \omega CR$$

When representing the electrical circuit parameters as phasors, a capacitor's dissipation factor is equal to the tangent of the angle between the capacitor's impedance phasor and the negative reactive axis, as shown in the *impedance triangle diagram* of [Figure 6.8](#) This gives rise to the parameter known as the loss tangent d where [Figure. 6.8 Impedance](#)

$$\tan \delta = \frac{R}{X_C} = \frac{R}{1/\omega C} = \omega CR$$

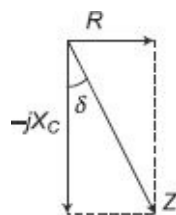

Figure. 6.8 *Impedance triangle diagram*

Loss tangent of a real capacitor can also be defined in the *voltage triangle diagram* of [Figure 6.9](#) as the ratio of voltage drop across the ESR to the voltage drop across the capacitor only, i.e. tangent of the angle between the capacitor voltage only and the total voltage drop across the combination of capacitor and ESR.

$$\tan \delta = \frac{V_R}{V_C} = \frac{iR}{iX_C} = \frac{R}{1/\omega C} = \omega CR$$

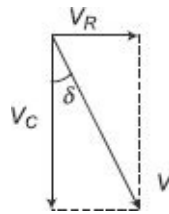

Figure 6.9 Voltage triangle diagram

Though the expressions for dissipation factor (*DF*) and loss tangent ($\tan \delta$) are the same, normally the dissipation factor is used at lower frequencies, whereas the loss tangent is more applicable for high frequency applications. A good capacitor will normally have low values of dissipation factor (*DF*) and loss tangent ($\tan \delta$).

In addition to *ESR*, *DF* and loss tangent, the other parameter used to quantify performance of a real capacitor is its Quality Factor or *Q*-Factor. Essentially for a capacitor it is the ratio of the energy stored to that dissipated per cycle.

$$Q = \frac{i^2 X_C}{i^2 R} = \frac{X_C}{R}$$

It can thus be deduced that the *Q* can be expressed as the ratio of the capacitive reactance to the *ESR* at the frequency of interest.

$$Q = \frac{X_C}{R} = \frac{1}{\omega CR} = \frac{1}{DF} = \frac{1}{\tan \delta}$$

A high quality capacitor (high *Q*-factor) will thus have low values of dissipation factor (*DF*) and loss tangent ($\tan \delta$), i.e. less losses.

The most commonly used bridges for capacitance measurement are De Sauty's bridge and Schering Bridge.

6.5.1 De Sauty's Bridge

This is the simplest method of finding out the value of a unknown capacitor in terms of a known standard capacitor. Configuration and phasor diagram of a De Sauty's bridge under balanced condition is shown in [Figure 6.10](#).

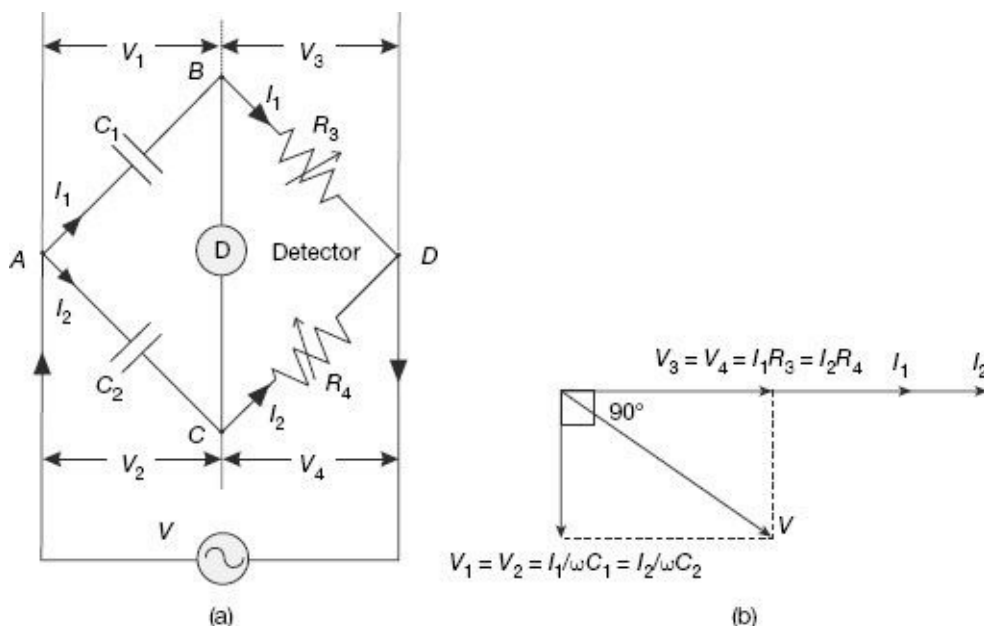

Figure 6.10 De Sauty's bridge under balanced condition: (a) Configuration (b) Phasor diagram

The unknown capacitor C_1 in the branch AB is compared with the standard known capacitor C_2 on arm AC . The bridge can be balanced by varying either of the non-inductive resistors R_3 or R_4 .

Under balanced condition, since no current flows through the detector, nodes B and C are at the same potential, i.e., $V_1 = V_2$ and $V_3 = V_4$.

As shown in the phasor diagram of Figure 6.7 (b), $V_3 = I_1 R_3$ and $V_4 = I_2 R_4$ being equal both in magnitude and phase, they overlap. Current I_1 in the arm BD and I_2 in the arm CD are also in the same phase with $I_1 R_3$ and $I_2 R_4$ along the horizontal line. Capacitive voltage drop $V_1 = I_1 / \omega C_1$ in the arm AB lags behind I_1 by 90° . Similarly, the other capacitive voltage drop $V_2 = I_2 / \omega C_2$ in the arm AC lags behind I_2 by 90° . Under balanced condition, these two voltage drops V_1 and V_2 being equal in magnitude and phase, they overlap each other along the vertical axis as shown in Figure 6.7 (b). Finally, phasor summation of V_1 and V_3 (or V_2 and V_4) results in the supply voltage V .

$$\text{At balance, } \frac{\left(\frac{1}{j\omega C_1}\right)}{R_3} = \frac{\left(\frac{1}{j\omega C_2}\right)}{R_4}$$

or, $C_1 = C_2 \frac{R_4}{R_3}$ (6.28)

The advantage of De Sauty's bridge is its simplicity. However, this advantage may be nullified by impurities creeping in the measurement if the capacitors are not free from dielectric losses. This method is thus best suited for loss-less air capacitors.

In order to make measurement in capacitors having inherent dielectric losses, the *modified De Sauty's bridge* as suggested by Grover, can be used. This bridge is also called the *series resistance-capacitance bridge*. Configuration of such a bridge and its corresponding phasor diagram under balanced condition is shown in Figure 6.11.

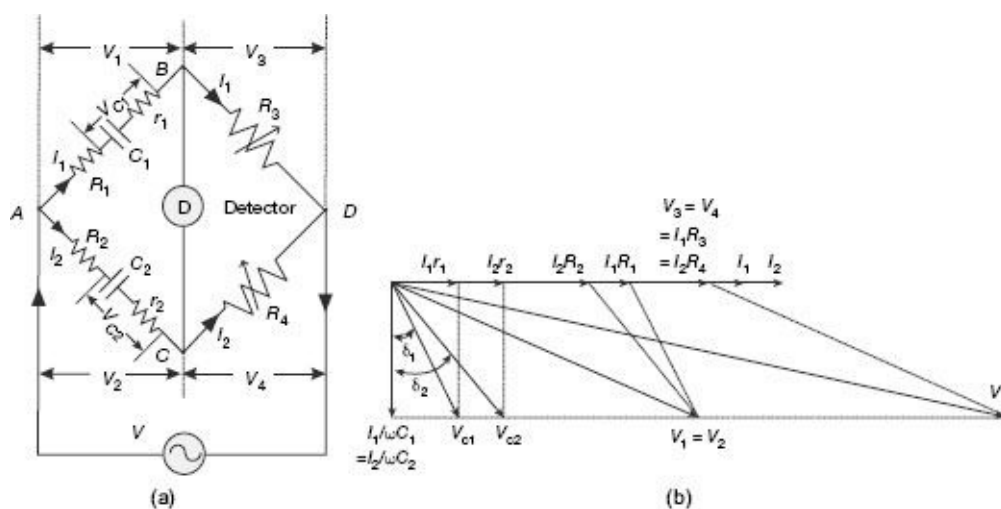

Figure 6.11 Modified De Sauty's bridge under balanced condition: (a) Configuration, and (b) Phasor diagram

The unknown capacitor C_1 with internal resistance r_1 representing losses in the branch AB is compared with the standard known standard capacitor C_2 along with its internal resistance r_2 on arm AC . Resistors R_1 and R_2 are connected externally in series with C_1

and C_2 respectively. The bridge can be balanced by varying either of the non-inductive resistors R_3 or R_4 .

Under balanced condition, since no current flows through the detector, nodes B and C are at the same potential, i.e., $V_1 = V_2$ and $V_3 = V_4$.

As shown in the phasor diagram of [Figure 6.11](#) (b), $V_3 = I_1R_3$ and $V_4 = I_2R_4$ being equal both in magnitude and phase, they overlap. Current I_1 in the arm BD and I_2 in the arm CD are also in the same phase with I_1R_3 and I_2R_4 along the horizontal line. The other resistive drops, namely, I_1R_1 in the arm AB and I_2R_2 in the arm AC are also along the same horizontal line. Finally, resistive drops inside the capacitors, namely, I_1r_1 and I_2r_2 are once again, in the same phase, along the horizontal line. Capacitive voltage drops $I_1/\omega C_1$ lags behind I_1r_1 by 90° . Similarly, the other capacitive voltage drop $I_2/\omega C_2$ lags behind I_2r_2 by 90° . Phasor summation of the resistive drop I_1r_1 and the quadrature capacitive drop $I_1/\omega C_1$ produces the total voltage drop V_{C1} across the series combination of capacitor C_1 and its internal resistance r_1 . Similarly, phasor summation of the resistive drop I_2r_2 and the quadrature capacitive drop $I_2/\omega C_2$ produces the total voltage drop V_{C2} across the series combination of capacitor C_2 and its internal resistance r_2 . d_1 and d_2 represent loss angles for capacitors C_1 and C_2 respectively. Phasor summation of I_1R_1 and V_{C1} gives the total voltage drop V_1 across the branch AB . Similarly, phasor summation of I_2R_2 and V_{C2} gives the total voltage drop V_2 across the branch AC . Finally, phasor summation of V_1 and V_3 (or V_2 and V_4) results in the supply voltage V .

$$\text{At balance, } \frac{\left(R_1 + r_1 + \frac{1}{j\omega C_1}\right)}{R_3} = \frac{\left(R_2 + r_2 + \frac{1}{j\omega C_2}\right)}{R_4}$$

$$\text{or, } R_1R_4 + r_1R_4 - \frac{jR_4}{\omega C_1} = R_2R_3 + r_2R_3 - \frac{jR_3}{\omega C_2}$$

Equating real and imaginary parts, we have

$$\frac{C_1}{C_2} = \frac{(R_2 + r_2)}{(R_1 + r_1)} = \frac{R_4}{R_3} \quad (6.29)$$

$$\therefore C_1 = C_2 \frac{R_4}{R_3} \quad (6.30)$$

The modified De Sauty's bridge can also be used to estimate dissipation factor for the unknown capacitor as described below:

Dissipation factor for the capacitors are defined as

$$D_1 = \tan \delta_1 = \frac{I_1 r_1}{I_1} = \omega C_1 r_1 \quad \text{and} \quad D_2 = \tan \delta_2 = \frac{I_2 r_2}{I_2} = \omega C_2 r_2 \quad (6.31)$$

From Eq. (6.29), we have

$$\frac{C_1}{C_2} = \frac{(R_2 + r_2)}{(R_1 + r_1)}$$

or, $C_2 r_2 - C_1 r_1 = C_1 R_1 - C_2 R_2$

or, $\omega C_2 r_2 - \omega C_1 r_1 = \omega C_1 R_1 - C_2 R_2$

Using Eq. (6.31), we get, $D - D = \omega (C_1 R_1 - C_2 R_2)$

or, $D_2 - D_1 = \omega (C_1 R_1 - C_2 R_2)$

Substituting the value of C_1 from Eq. (6.30), we have

$$D_2 - D_1 = \omega C_2 \left(\frac{R_1 R_4}{R_3} - R_2 \right) \quad (6.32)$$

Thus, dissipation factor for one capacitor can be estimated if dissipation factor of the other capacitor is known.

6.5.2 Schering Bridge

Schering bridges are most popularly used these days in industries for measurement of capacitance, dissipation factor, and loss angles. Figure 6.12 illustrates the configuration of a Schering bridge and corresponding phasor diagram under balanced condition.

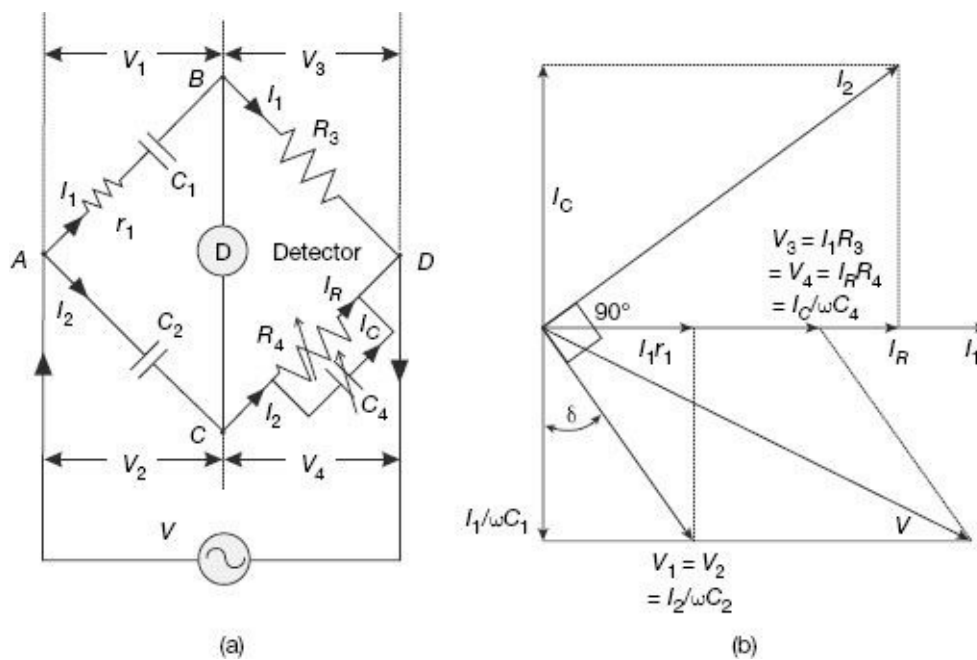

Figure 6.12 Schering bridge under balanced condition: (a) Configuration (b) Phasor diagram

The unknown capacitor C_1 along with its internal resistance r_1 (representing loss) placed on the arm AB is compared with the standard loss-less capacitor C_2 placed on the arm AC . This capacitor C_2 is either an air or a gas capacitor to make it loss free. R_3 is a non-inductive resistance placed on arm BD . The bridge is balanced by varying the capacitor C_4 and the non-inductive resistor R_4 parallel with C_4 , placed on arm CD .

Under balanced condition, since no current flows through the detector, nodes B and C are at the same potential, i.e., $V_1 = V_2$ and $V_3 = V_4$.

As shown in the phasor diagram of Figure 6.12 (b), $V_3 = I_1 R_3$ and $V_4 = I_R R_4$ being equal

both in magnitude and phase, they overlap. Current I_1 in the arm BD and I_R flowing through R_4 are also in the same phase with I_1R_3 and I_RR_4 along the horizontal line. The other resistive drop namely, I_1R_1 in the arm AB is also along the same horizontal line. The resistive current I_R through R_4 and the quadrature capacitive current I_C through C_4 will add up to the total current I_2 in the branch CD (and also in AC under balanced condition). Across the arm AB , the resistive drop I_1r_1 and the quadrature capacitive drop $I_1/\omega C_1$ will add up to the total voltage drop V_1 across the arm. At balance, voltage drop V_1 across arm AB will be same as the voltage drop $V_2 = I_2/\omega C_2$ across the arm AC . It can be confirmed from the phasor diagram in [Figure 6.12\(b\)](#) that the current I_2 has quadrature phase relationship with the capacitive voltage drop $I_2/\omega C_2$ in the arm AC . Finally, phasor summation of V_1 and V_3 (or V_2 and V_4) results in the supply voltage V .

$$\text{At balance, } \frac{\left(r_1 + \frac{1}{j\omega C_1}\right)}{R_3} = \frac{\left(\frac{1}{j\omega C_2}\right)}{\left(\frac{R_4}{1 + j\omega C_4 R_4}\right)}$$

$$\text{or, } R_4 \left(r_1 + \frac{1}{j\omega C_1}\right) = \left(\frac{R_3}{j\omega C_2}\right) (1 + j\omega C_4 R_4)$$

$$\text{or, } R_4 r_1 - \frac{jR_4}{\omega C_1} = \frac{R_3 R_4 C_4}{C_2} - \frac{jR_3}{\omega C_2}$$

Equating real and imaginary parts, we have the unknown quantities:

$$r_1 = \frac{R_3 C_4}{C_2} \quad (6.33)$$

and

$$C_1 = C_2 \frac{R_4}{R_3} \quad (6.34)$$

Dissipation Factor

$$D_1 = \tan \delta_1 = \frac{I_1 r_1}{I_1 / \omega C_1} = \omega C_1 r_1 = \omega \times C_2 \frac{R_4}{R_3} \times \frac{R_3 C_4}{C_2} = \omega R_4 C_4 \quad (6.35)$$

Thus, using Schering bridge, dissipation factor can be obtained in terms of the bridge parameters at balance condition.

6.6

MEASUREMENT OF FREQUENCY

6.6.1 Wien's Bridge

Wien's bridge is primarily used for determination of an unknown frequency. However, it can be used for various other applications including capacitance measurement, in harmonic distortion analysers, where it is used as notch filter, and also in audio and HF

oscillators.

Configuration of a Wien's bridge for determination of unknown frequency and corresponding phasor diagram under balanced condition is shown in [Figure 6.13](#).

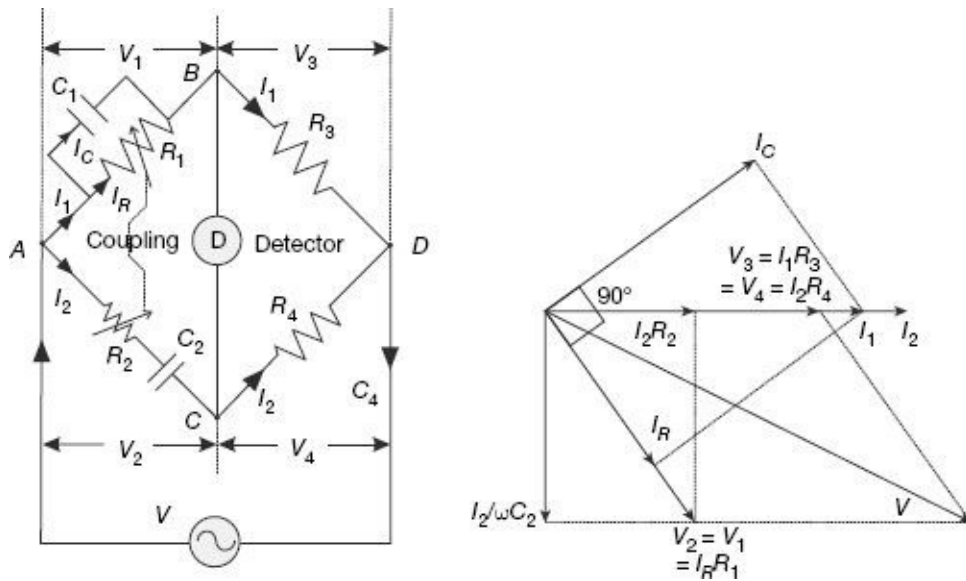

Figure 6.13 Wien's bridge under balanced condition: (a) Configuration (b) Phasor diagram

Under balanced condition, since no current flows through the detector, nodes B and C are at the same potential, i.e., $V_1 = V_2$ and $V_3 = V_4$.

As shown in the phasor diagram of [Figure 6.13](#) (b), $V_3 = I_1 R_3$ and $V_4 = I_2 R_4$ being equal both in magnitude and phase, they overlap. Current I_1 in the arm BD and I_2 flowing through R_4 are also in the same phase with $I_1 R_3$ and $I_2 R_4$ along the horizontal line. The other resistive drop, namely, $I_2 R_2$ in the arm AC is also along the same horizontal line. The resistive voltage drop $I_R R_2$ across R_2 and the quadrature capacitive drop $I_2 / \omega C_2$ across C_2 will add up to the total voltage drop V_2 in the arm AC. Under balanced condition, voltage drops across arms AB and AC are equal, thus $V_1 = V_2$ both in magnitude and phase. The voltage V_1 will be in the same phase as the voltage drop $I_R R_1$ across the resistance R_1 in the same arm AB. The resistive current I_R will thus be in the same phase as the voltage $V_1 = I_R R_1$. Phasor addition of the resistive current I_R and the quadrature capacitive current I_C , which flows through the parallel $R_1 C_1$ branch, will add up to the total current I_1 in the arm AB. Finally, phasor summation of V_1 and V_3 (or V_2 and V_4) results in the supply voltage V .

$$\text{At balance, } \frac{\left(\frac{R_1}{1 + j\omega C_1 R_1} \right)}{R_3} = \frac{\left(R_2 - \frac{j}{\omega C_2} \right)}{R_4}$$

$$\text{or, } \frac{R_1 R_4}{1 + j\omega C_1 R_1} = \frac{\omega C_2 R_2 R_3 - j R_3}{\omega C_2}$$

$$\text{or, } \omega C_2 R_1 R_4 = \omega C_2 R_2 R_3 - j R_3 + j \omega^2 C_1 C_2 R_1 R_2 R_3 + \omega C_1 R_1 R_3$$

$$\text{or, } \omega (C_2 R_1 R_4) = \omega (C_2 R_2 R_3 + C_1 R_1 R_3) - j (R_3 - \omega^2 C_1 C_2 R_1 R_2 R_3)$$

Equating real and imaginary parts, we get

$$C_2 R_1 R_4 = C_2 R_2 R_3 + C_1 R_1 R_3$$

$$\text{or, } \frac{R_4}{R_3} = \frac{R_2}{R_1} + \frac{C_1}{C_2} \quad (6.36)$$

and

$$\omega^2 C_1 C_2 R_1 R_2 R_3 = R_3$$

$$\text{or, } \omega = \sqrt{\frac{1}{C_1 C_2 R_1 R_2}}$$

$$\text{or, } f = \frac{1}{2\pi \sqrt{C_1 C_2 R_1 R_2}} \quad (6.37)$$

In most bridges, the parameters are so chosen that,

$$R_1 = R_2 = R \text{ and } C_1 = C_2 = C$$

Then, from Eq. (6.37), we get

$$f = \frac{1}{2\pi RC} \quad (6.38)$$

Sliders for the resistors R_1 and R_2 are mechanically coupled to satisfy the criteria $R_1 = R_2$.

Wien's bridge is frequency sensitive. Thus, unless the supply voltage is purely sinusoidal, achieving balance may be troublesome, since harmonics may disturb balance condition. Use of filters with the null detector in such cases may solve the problem.

Example 6.4

The four arms of a bridge are connected as follows:

Arm AB: A capacitor C_1 with an equivalent series resistance r_1

Arm BC: A noninductive resistance R_3

Arm CD: A noninductive resistance R_4

Arm DA: A capacitor C_2 with an equivalent series resistance r_2 in series with a resistance R_2

A supply of 500 Hz is given between terminals A and C and the detector is connected between nodes B and D. At balance, $R_2 = 5 \Omega$, $R_3 = 1000 \Omega$, $R_4 = 3000 \Omega$, $C_2 = 0.3 \mu\text{F}$ and $r_2 = 0.25 \Omega$. Calculate the values of C_1 and r_1 , and also dissipation factor of the capacitor.

Solution The configuration can be shown as

$$\text{At balance, } \frac{r_1 + \frac{1}{j\omega C_1}}{1000} = \frac{5.25 + \frac{1}{j2\pi \times 500 \times 0.3 \times 10^{-6}}}{3000}$$

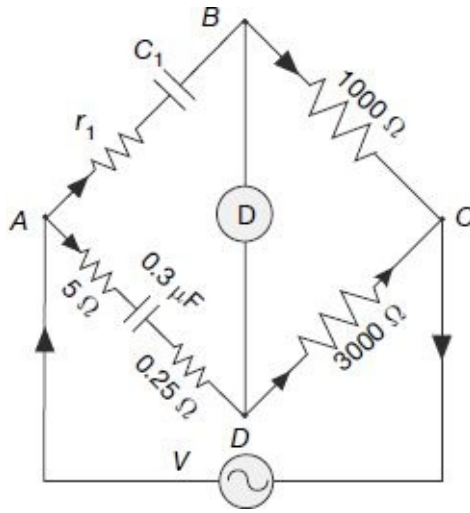

or,

$$3r_1 + \frac{3}{j\omega C_1} = 5.25 + \frac{1}{j2\pi \times 500 \times 0.3 \times 10^{-6}}$$

Equating real and imaginary terms, we get

$$r_1 = \frac{5.25}{3} = 1.75 \Omega$$

and,

$$\frac{3}{j2\pi \times 500 \times C_1} = \frac{1}{j2\pi \times 500 \times 0.3 \times 10^{-6}}$$

or,

$$C_1 = 3 \times 0.3 \times 10^{-6} = 0.9 \mu\text{F}$$

Example 6.5

The four arms of a bridge supplied from a sinusoidal source are configured as follows:

Arm AB: A resistance of 100Ω in parallel with a capacitance of $0.5 \mu\text{F}$

Arm BC: A 200Ω noninductive resistance

Arm CD: A 800Ω noninductive resistance

Arm DA: A resistance R_x in series with a $1 \mu\text{F}$ capacitance

Determine the value of R_x and the frequency at which the bridge will balance.

Supply is given between terminals A and C and the detector is connected between nodes B and D.

Solution The configuration can be shown as

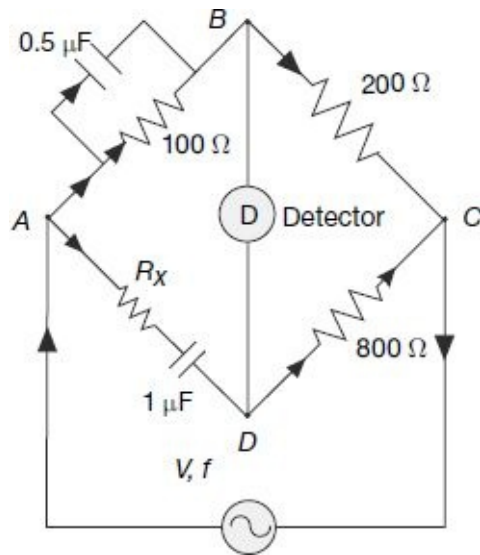

The configuration shows that it is a Wien's bridge. Thus, following Eq. (6.36), the balance equation can be written as

$$\frac{R_4}{R_3} = \frac{R_x}{R_1} + \frac{C_1}{C_2}$$

Thus,

$$R_x = R_1 \times \left(\frac{R_4}{R_3} - \frac{C_1}{C_2} \right) = 100 \times \left(\frac{800}{200} - \frac{0.5 \times 10^{-6}}{1 \times 10^{-6}} \right) = 350 \Omega$$

The frequency at which bridge is balanced is given by Eq. (6.37):

$$f = \frac{1}{2\pi \sqrt{0.5 \times 10^{-6} \times 1 \times 10^{-6} \times 100 \times 350}} = 1203 \text{ Hz}$$

6.7

WAGNER EARTHING DEVICE

A serious problem encountered in sensitive ac bridge circuits is that due to stray capacitances. Stray capacitances may be formed in an ac bridge between various junction points within the bridge configuration and nearest ground (earthed) object. These stray capacitors affect bridge balance in severe ways since these capacitors carry leakage current when the bridge is operated with ac, especially at high frequencies. Formation of such stray capacitors in a simple ac bridge circuit is schematically shown in Figure 6.14.

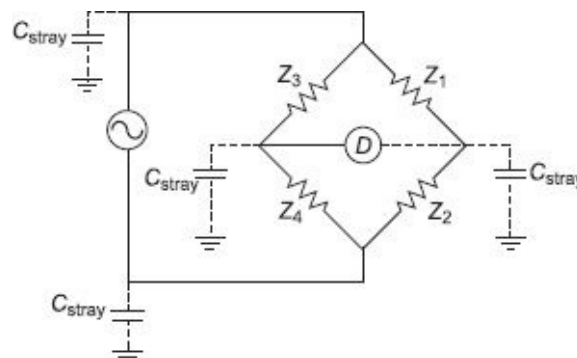

Figure 6.14 Formation of stray capacitors in an ac bridge

One possible way of reducing this effect is to keep the detector at ground potential, so there will be no ac voltage between it and the ground, and thus no current through [Figure 6.14](#)

Formation of stray capacitors in an ac bridge the stray capacitances can leak out. However, directly connecting the null detector to ground is not an option, since it would create a direct current path for other stray currents. Instead, a special voltage-divider circuit, called a *Wagner ground* or *Wagner earth*, may be used to maintain the null detector at ground potential without having to make a direct connection between the detector and ground.

The Wagner earth circuit is nothing more than a voltage divider as shown in Figure 6.15. There are two additional (auxiliary) arms Z_A and Z_B in the bridge configuration with a ground connection at their junction E . The switch S is used to connect one end of the detector alternately to the ground point e and the bridge connection point d . The two impedances Z_A and Z_B must be made of such components (R , L , or C) so that they are capable of forming a balanced bridge with the existing bridge arm pairs Z_1-Z_2 or Z_3-Z_4 . Stray capacitances formed between bridge junctions and the earthing point E are shown as C_1 , C_2 , C_3 and C_4 .

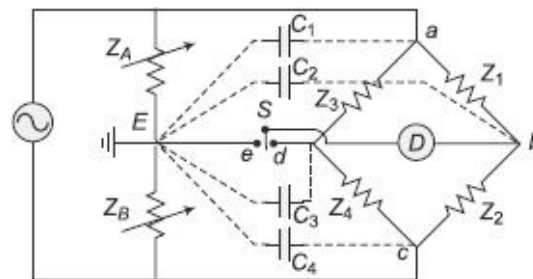

Figure 6.15 Wagner earthing device

The bridge is first balanced with the arms Z_1-Z_2 and Z_3-Z_4 with the switch at the position d . The switch is next thrown to position e and balance is once again attained between arms Z_1-Z_2 and Z_5-Z_6 . The process is repeated till both bridge configurations become balanced. At this point, potential at the points b , d , e are the same and are all at earth potential. Thus, the Wagner earthing divider forces the null detector to be at ground potential, without a direct connection between the detector and ground. Under these conditions, no current can flow through the stray capacitors C_2 and C_3 since their terminals are both at earth potential. The other two stray capacitors C_1 and C_4 become part of (shunt to) the Wagner arms Z_A and Z_B , and thus get eliminated from the original bridge network.

The Wagner earthing method gives satisfactory results from the point of view of eliminating stray capacitance charging effects in ac bridges, but the entire balancing process is time consuming at times.

EXERCISE

Objective-type Questions

1. A bridge circuit works at a frequency of 2 kHz. Which of the following can be used as null detector in such a bridge?
 - (a) Vibration galvanometers and tunable amplifiers
 - (b) Headphones and tunable amplifiers

- (c) Vibration galvanometers and headphones
 - (d) All of the above
2. Under balanced condition of a bridge for measuring unknown impedance, if the detector is suddenly taken out
 - (a) measured value of the impedance will be lower
 - (b) measured value of the impedance will be higher
 - (c) measured value of the impedance will not change
 - (d) the impedance can not be measured
 3. Harmonic distortions in power supply does not affect the performance of Maxwell's bridge since
 - (a) filters are used to remove harmonics
 - (b) final expression for unknown inductance contain only fundamental frequency
 - (c) mechanical resonance frequency of null detectors are beyond the range of harmonic frequencies
 - (d) final expression for unknown inductance is independent of frequency
 4. Maxwell's bridge can be used for measurement of inductance with
 - (a) high Q factors
 - (b) very low Q factors
 - (c) medium Q factors
 - (d) wide range of Q factor variations
 5. The advantage of Hay's bridge over Maxwell's inductance–capacitance bridge is that
 - (a) its final balance equations are independent of frequency
 - (b) it reduces cost by not making capacitor or inductor as the variable parameters
 - (c) it can be used measuring low Q inductors
 - (d) it can be used measuring high Q inductors
 6. The advantage of Anderson's bridge over Maxwell's bridge is that
 - (a) its final balance equations are independent of inductor losses
 - (b) it reduces cost by not making capacitor or inductor as the variable parameters
 - (c) number of bridge components required are less
 - (d) attaining balance condition is easier and less time consuming
 7. The main advantage of Owen's bridge for measurement of unknown inductance is that
 - (a) it has two independent elements R and C for achieving balance
 - (b) it can be used for measurement of very high Q coils
 - (c) it is very inexpensive
 - (d) it can be used for measurement of unknown capacitance as well
 8. DeSauty's bridge is used for measurement of
 - (a) high Q inductances
 - (b) low Q inductances
 - (c) loss less capacitors
 - (d) capacitors with dielectric losses
 9. Schering bridge can be used for measurement of
 - (a) capacitance and dissipation factor
 - (b) dissipation factor only
 - (c) inductance with inherent loss
 - (d) capacitor but not dissipation factor

10. Frequency can be measured using
- Anderson's bridge
 - Maxwell's bridge
 - De Sauty's bridge
 - Wien's bridge

Answers						
1. (b)	2. (c)	3. (d)	4. (c)	5. (d)	6. (b)	7. (a)
8. (c)	9. (a)	10. (d)				

Short-answer Questions

- Derive the general equations for balance in ac bridges. Show that both magnitude and phase conditions need to be satisfied for balancing an ac bridge.
- Derive the expression for balance in Maxwell's inductance bridge. Draw the phasor diagram under balanced condition.
- Show that the final balance expressions are independent of supply frequency in a Maxwell's bridge. What is the advantage in having balance equations independent of frequency?
- Discuss the advantages and disadvantages of Maxwell's bridge for measurement of unknown inductance.
- Explain why Maxwell's inductance–capacitance bridge is suitable for measurement of inductors having quality factor in the range 1 to 10.
- Explain with the help of phasor diagram, how unknown inductance can be measured using Owen's bridge.
- Explain how Wien's bridge can be used for measurement of unknown frequencies. Derive the expression for frequency in terms of bridge parameters.

Long-answer Questions

- Explain with the help of a phasor diagram, how unknown inductance can be measured using Maxwell's inductance–capacitance bridge.
 - The following data relate to a basic ac bridge:

$$\bar{Z}_1 = 50 \Omega \angle 80^\circ \quad \bar{Z}_2 = 125 \Omega \quad \bar{Z}_3 = 200 \Omega \angle 30^\circ \quad \bar{Z}_4 = \text{unknown}$$

Determine the unknown arm parameters.

[10 + 5]

- Describe the working of Hay's bridge for measurement of inductance. Derive the equations for balance and draw the phasor diagram under balanced condition. Explain how this bridge is suitable for measurement of high Q chokes?
- Derive equations for balance for an Anderson's bridge. Draw its phasor diagram under balance. What are its advantages and disadvantages?
- Describe how unknown capacitors can be measured using De Sauty's bridge. What are the limitations of this bridge and how they can be overcome by using a modified De Sauty's bridge? Draw relevant phasor diagrams
- Describe the working of a Schering bridge for measurement of capacitance and dissipation factor. Derive relevant equations and draw phasor diagram under balanced condition.
- In an Anderson's bridge for measurement of inductance, the arm AB consists of an unknown impedance with L and R , the arm BC contains a variable resistor, fixed resistances of 500Ω each in arms CD and DA , a known variable resistance in the arm DE , and a capacitor of fixed capacitance $2 \mu\text{F}$ in the arm CE . The ac supply of 200 Hz is connected across A and C , and the detector is connected between B and E . If balance is obtained with a resistance of 300Ω in the arm DE and a resistance of 600Ω in the arm BC , calculate values of unknown impedance L and R . Derive the relevant equations for balance and draw the phasor diagram.
- The four arms of a Maxwell's inductance–capacitance bridge at balance are Arm AB : A choke coil L_1 with an equivalent series resistance R_1 Arm BC : A non-inductive resistance of 800Ω Arm CD : A mica capacitor of $0.3 \mu\text{F}$ in parallel with a noninductive resistance of 800Ω Arm DA : A non-inductive resistance 800Ω Supply is given between terminals A and C and the detector is connected between nodes B and D . Derive the equations for balance

of the bridge and hence determine values of L_1 and R_1 . Draw the phasor diagram of the bridge under balanced condition.

8. The four arms of a Hay's bridge used for measurement of unknown inductance is configured as follows: Arm AB : A choke coil of unknown impedance Arm BC : A non-inductive resistance of 1200Ω Arm CD : A non-inductive resistance of 900Ω in series with a standard capacitor of $0.4 \mu\text{F}$ Arm DA : A noninductive resistance 18000Ω If a supply of 300 V at 50 Hz is given between terminals A and C and the detector is connected between nodes B and D , determine the inductance and inherent resistance of the unknown choke coil. Derive the conditions for balance and draw the phasor diagram under balanced condition.
9. A capacitor busing forms the arm AB of a Schering bridge and a standard capacitor of $400 \mu\text{F}$ capacitance and negligible loss, form the arm AD . Arm BC consists of a non-inductive resistance of 200Ω . When the detector connected between nodes B and D shows no deflection, the arm CD has a resistance of 82.4Ω in parallel with a capacitance of $0.124 \mu\text{F}$. The supply frequency is 50 Hz . Calculate the capacitance and dielectric loss angle of the capacitor. Derive the equations for balance and draw the relevant phasor diagram at balanced state.
10. (a) An ac bridge is configured as follows:
 - Arm AB : A resistance of 600Ω in parallel with a capacitance of $0.3 \mu\text{F}$
 - Arm BC : An unknown non-inductive resistance
 - Arm CD : A noninductive resistance of 1000Ω
 - Arm DA : A resistance of 400Ω in series with a capacitance of $0.1 \mu\text{F}$If a supply is given between terminals A and C and the detector is connected between nodes B and D , find the resistance required in the arm BC and also the supply frequency for the bridge to be balanced.
- (b) Explain how Wien's bridge can be used for measurement of unknown frequency. Draw the phasor diagram under balanced condition and derive the expression for balance.

7

Power Measurement

7.1

INTRODUCTION

Measurement of electric power is as essential in industry as in commercial or even domestic applications. Prior estimation and subsequent measurements of instantaneous and peak power demands of any installation are mandatory for design, operation and maintenance of the electric power supply network feeding it. Whereas an under-estimation of power demand may lead to blowing out of power supply side accessories, on the other hand, over-estimation can end up with over-design and additional cost of installation. Knowledge about accurate estimation, calculation and measurement of electric power is thus of primary concern for designers of new installations. In this chapter, the most popular power measurement methods and instruments in dc and ac circuits are illustrated.

7.2

POWER MEASUREMENT IN dc CIRCUITS

Electric power (P) consumed by a load (R) supplied from a dc power supply (V_S) is the product of the voltage across the load (V_R) and the current flowing through the load (I_R):

$$P = V_R \times I_R \quad (7.1)$$

Thus, power measurement in a dc circuit can be carried out using a voltmeter (V) and an ammeter (A) using any one of the arrangements shown in [Figure 7.1](#).

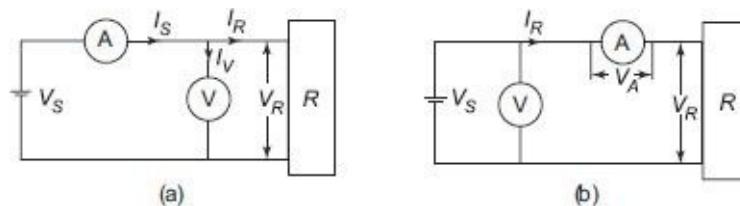

Figure 7.1 Two arrangements for power measurement in dc circuits

One thing should be kept in mind while using any of the two measuring arrangements shown in [Figure 7.1](#); that both the voltmeter and the ammeter requires power for their own operations. In the arrangement of [Figure 7.1\(a\)](#), the voltmeter is connected between the load and the ammeter. The ammeter thus, in this case measures the current flowing into the voltmeter, in addition to the current flowing into the load.

$$\begin{aligned} \text{Current through the voltmeter} &= I_V = V_R/R_V \\ \text{where, } R_V &\text{ is the internal resistance of the voltmeter.} \end{aligned} \quad (7.2)$$

$$\begin{aligned} \text{Power consumed by the load} &= V_R \times I_R = V_R \times (I_S - I_V) \\ &= V_R \times I_S - V_R \times I_V \\ &= V_R \times I_S - V_R^2/R_V \\ &= \text{Power indicated by instruments} - \text{Power loss in voltmeter} \end{aligned} \quad (7.3)$$

Thus, Power indicated = Power consumed + Power loss in voltmeter

In the arrangement of Figure 7.1(b), the voltmeter measures the voltage drop across the ammeter in addition to that dropping across the load.

$$\text{Voltage drop across ammeter} = V_A = I_R \times R_A \tag{7.4}$$

where, R_A is the internal resistance of the ammeter.

$$\begin{aligned} \text{Power consumed by the load} &= V_R \times I_R = (V_S - V_A) \times I_R \\ &= V_S \times I_R - V_A \times I_R \\ &= V_S \times I_R - I_R^2 \times R_A \\ &= \text{power indicated by instruments} - \text{Power loss in ammeter} \end{aligned} \tag{7.5}$$

Thus, Power indicated = Power consumed + Power loss in Ammeter

Thus, both arrangements indicate the additional power absorbed by the instruments in addition to indicating the true power consumed by the load only. The corresponding measurement errors are generally referred to as insertion errors.

Ideally, in theory, if we consider voltmeters to have infinite internal impedance and ammeters to have zero internal impedance, then from (7.3) and (7.5) one can observe that the power consumed by the respective instruments go down to zero. Thus, in ideal cases, both the two arrangements can give correct indication of the power consumed by the load. Under practical conditions, the value of power loss in instruments is quite small, if not totally zero, as compared with the load power, and therefore, the error introduced on this account is small.

Example 7.1

Two incandescent lamps with 80 Ω and 120 Ω resistances are connected in series with a 200 V dc source. Find the errors in measurement of power in the 80 Ω lamp using a voltmeter with internal resistance of 100 kΩ and an ammeter with internal resistance of 0.1 mΩ, when (a) the voltmeter is connected nearer to the lamp than the ammeter, and (b) when the ammeter is connected nearer to the lamp than the voltmeter

Solution Assuming both the instruments to be ideal, i.e., the voltmeter with infinite internal impedance and ammeter with zero internal impedance, the current through the series circuit should be

$$= 200 / (80 + 120) = 1 \text{ A}$$

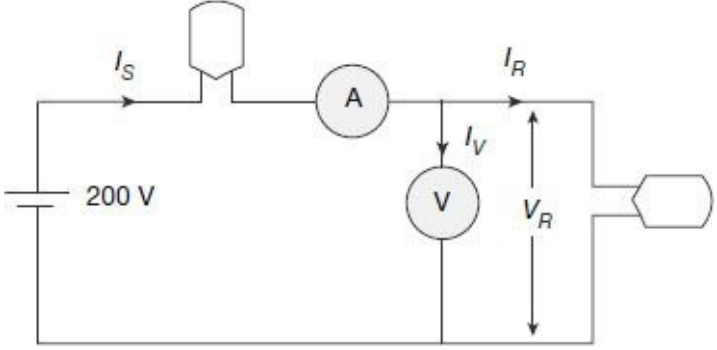

Figure 7.2 Actual connections for Example 7.1(a)

Hence, true power consumed by the 80 Ω lamp would have been

$$= 1^2 \times 80 = 80 \Omega$$

However, considering the internal resistance of the ammeter and voltmeter, the equivalent circuit will look like **Figure 7.3**.

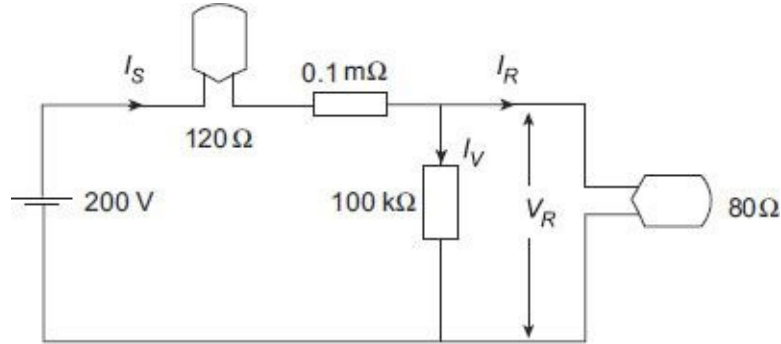

Figure 7.3 Equivalent circuit for Example 7.1(a)

Supply current (ammeter reading)

$$\begin{aligned}
 I_S &= \text{Supply voltage} / \text{Equivalent resistance of the circuit} \\
 &= \frac{\text{Supply voltage}}{(\text{Series of Lamp 1 and ammeter}) + (\text{Parallel of Lamp 2 and voltmeter})} \\
 &= 200 / \left((120 + 0.1 \times 10^{-3}) + \frac{(100 \times 10^3 \times 80)}{(100 \times 10^3 + 80)} \right) \\
 &= 1.0003 \text{ A}
 \end{aligned}$$

Actual current through the 80 Ohm lamp is

$$\begin{aligned}
 I_R &= 1.0003 \times \frac{100 \times 10^3}{100 \times 10^3 + 80} \text{ A} \\
 &= 0.9995 \text{ A}
 \end{aligned}$$

Voltage across the 80 Ohm lamp (voltmeter reading) is

$$\begin{aligned}
 V_R &= I_R \times 80 \\
 &= 79.962 \text{ V}
 \end{aligned}$$

Thus, actual power consumed by the 80 Ohm lamp is

$$V_R \times I_R = 79.962 \times 0.9995 = 79.922 \text{ W}$$

Power consumption as indicated by the two meters

$$\begin{aligned}
 &= \text{Voltmeter reading} \times \text{Ammeter reading} \\
 &= 79.962 \times 1.0003 = 79.986 \text{ W}
 \end{aligned}$$

(b) In this case, the actual circuit and its equivalent will look like **Figure 7.4**.

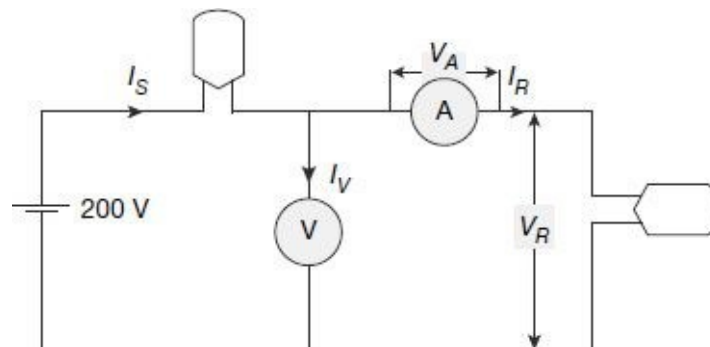

Figure 7.4 Actual connection for Example 7.1(b)

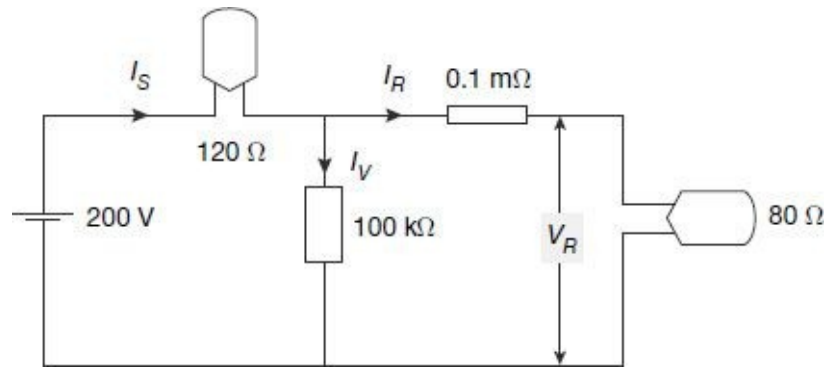

Figure 7.5 Equivalent circuit for Example 7.1(a)

Supply current

$$\begin{aligned}
 I_S &= \text{Supply voltage/Equivalent resistance of the circuit} \\
 &= \frac{\text{Supply voltage}}{\text{Series of Lamp 1 and [Parallel of voltmeter and (Series of ammeter and Lamp 2)]}} \\
 &= 200 / \left(120 + \frac{[100 \times 10^3 \times (80 + 0.1 \times 10^{-3})]}{100 \times 10^3 + (80 + 0.1 \times 10^{-3})} \right) \\
 &= 1.003 \text{ A}
 \end{aligned}$$

Current through the 80 Ω lamp (ammeter reading) is

$$\begin{aligned}
 I_R &= 1.0003 \times \frac{100 \times 10^3}{100 \times 10^3 + (80 + 0.1 \times 10^{-3})} \\
 &= 0.9995 \text{ A}
 \end{aligned}$$

Voltage across the 80 Ω lamp

$$= I_R \times 80 = 79.96 \text{ V}$$

Voltmeter reading

$$\begin{aligned}
 &= I_V \times 100 \times 10^3 \\
 &= (I_S - I_R) \times 100 \times 10^3 = 80 \text{ V}
 \end{aligned}$$

Thus, actual power consumed by the 80 Ω lamp is

$$V_R \times I_R = 79.96 \times 0.9995 = 79.92 \text{ W}$$

Power consumption as indicated by the two meters

$$\begin{aligned}
 &= \text{Voltmeter reading} \times \text{Ammeter reading} \\
 &= 80 \times 0.9995 = 79.96 \text{ W}
 \end{aligned}$$

Thus, we can have the following analysis:

Case	Power Consumption by 80 W lamp (W)			% Error from ideal
	Ideal Power	Actual Power	Meter Indication	
a	80	79.922	79.986	0.0175
b	80	79.92	79.96	0.05

Power in dc circuits can also be measured by wattmeter. Wattmeter can give direct indication of power and there is no need to multiply two readings as in the case when ammeter and voltmeter is used.

The type of wattmeter most commonly used for such power measurement is the *dynamometer*. It is built by (1) two fixed coils, connected in series and positioned coaxially with space between them, and (2) a moving coil, placed between the fixed coils and fitted with a pointer. Such a construction for a dynamometer-type wattmeter is shown in [Figure 7.6](#).

It can be shown that the torque produced in the dynamometer is proportional to the product of the current flowing through the fixed coils times that through the moving coil.

The fixed coils, generally referred to as current coils, carry the load current while the moving coil, generally referred to as voltage coil, carries a current that is proportional, via the multiplier resistor R_V , to the voltage across the load resistor R . As a consequence, the deflection of the moving coil is proportional to the power consumed by the load.

A typical connection of such a wattmeter for power measurement in dc circuit is shown in Figure 7.7.

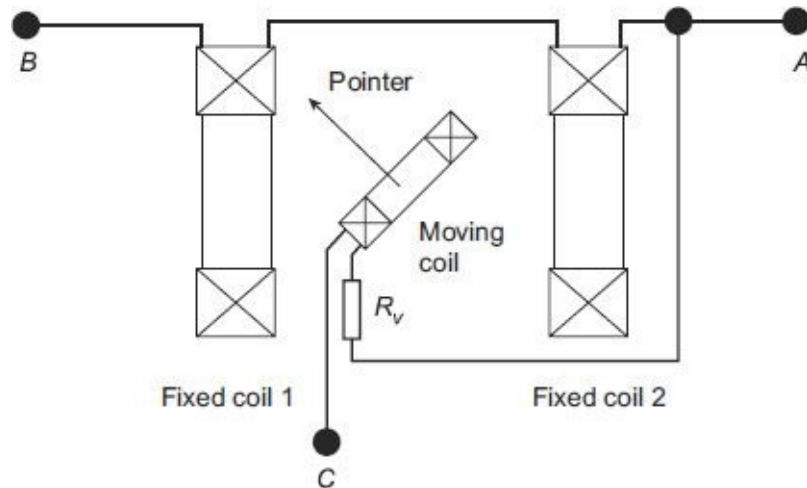

Figure 7.6 Basic construction of dynamometer-type wattmeter

In such a connection of the wattmeter, the insertion error, as in the previous case with ammeter and voltmeter, still exists. Relative β positioning of the current coil and the voltage coil with respect to load, introduce similar V_S errors in measurement of actual power. In particular, by connecting the voltage coil between A and C (Figure 7.7), the current coils carry the surplus current flowing through the voltage coil. On the other hand, by connecting the moving coil between B and C, this current error can be avoided, but now the voltage coil measures the surplus voltage drop across the current coils.

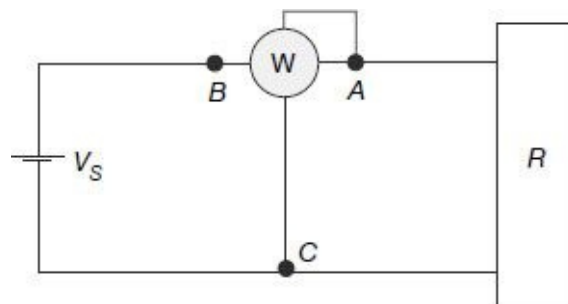

Figure 7.7 Connection of dynamometer-type wattmeter for power measurement in dc circuit

7.3

POWER MEASUREMENT IN ac CIRCUITS

In alternating current circuits, the instantaneous power varies continuously as the voltage and current varies while going through a cycle. In such a case, the power at any instant is given by

$$p(t) = v(t) \times i(t) \tag{7.6}$$

where, $p(t)$, $v(t)$, and $i(t)$ are values of instantaneous power, voltage, and current

respectively.

Thus, if both voltage and current can be assumed to be sinusoidal, with the current lagging the voltage by phase-angle ϕ , then

$$v(t) = V_m \sin \omega t$$

and
$$i(t) = I_m \sin (\omega t - \phi)$$

where, V_m and I_m are peak values of voltage and current respectively, and ω is the angular frequency.

The instantaneous power p is therefore given by

$$p(t) = V_m I_m \sin \omega t \sin (\omega t - \phi) \quad (7.7)$$

or,
$$p(t) = \frac{V_m I_m}{2} [\cos \phi - \cos(2\omega t - \phi)]$$

Average value of power over a complete cycle in such a case will be

$$\begin{aligned} P &= \frac{1}{2T} \int_0^{2T} p(t) dt = \frac{1}{2T} \int_0^{2T} \frac{V_m I_m}{2} [\cos \phi - \cos(2\omega t - \phi)] dt \\ &= \frac{V_m I_m}{2T} \int_0^{2T} \left[\cos \phi - \cos \left(\frac{4\pi}{T} t - \phi \right) \right] dt \\ &= \frac{V_m I_m}{2T} \left[\cos \phi t \Big|_0^T - \frac{T}{4\pi} \sin \left(\frac{4\pi}{T} t - \phi \right) \Big|_0^T \right] \\ &= \frac{V_m I_m}{4T} [\cos \phi T - 0] \\ &= \frac{V_m I_m}{2} \cos \phi \\ &= \frac{V_m}{\sqrt{2}} \frac{I_m}{\sqrt{2}} \cos \phi \\ &= V I \cos \phi \end{aligned} \quad (7.8)$$

where, V and I are rms values of voltage and current respectively and $\cos \phi$ is power factor of the load.

Involvement of the power-factor term $\cos \phi$ in the expression for power in ac circuit indicates that ac power cannot be measured simply by connecting a pair of ammeter and voltmeter. A wattmeter, with in-built facility for taking in to account the power factor, can only be used for measurement of power in ac circuits.

Figure 7.8 plots the waveforms of instantaneous power $p(t)$, voltage $v(t)$, and current $i(t)$.

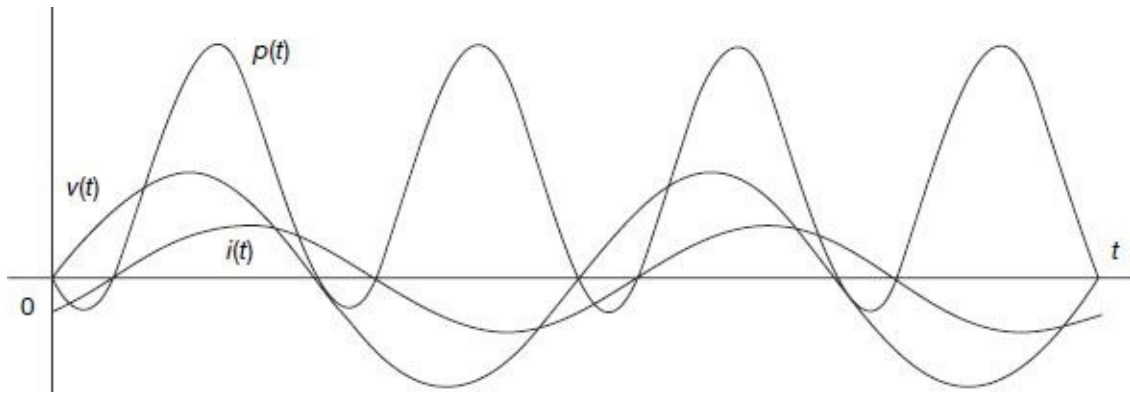

Figure 7.8 Plot of the waveforms of instantaneous power voltage and current in ac circuit

Readers may find interesting to note in [Figure 7.8](#) that though voltage and current waveforms have zero average value over a complete cycle, the instantaneous power has offset above zero having non-zero average value.

7.4

ELECTRODYNAMOMETER-TYPE WATTMETER

An electrodynamicometer-type wattmeter is similar in design and construction with the analog electrodynamicometer-type ammeter and voltmeter described in [Chapter 2](#).

7.4.1 Construction of Electrodynamicometer-type Wattmeter

Schematic diagram displaying the basic constructional features of an electrodynamicometer-type wattmeter is shown in [Figure 7.9](#).

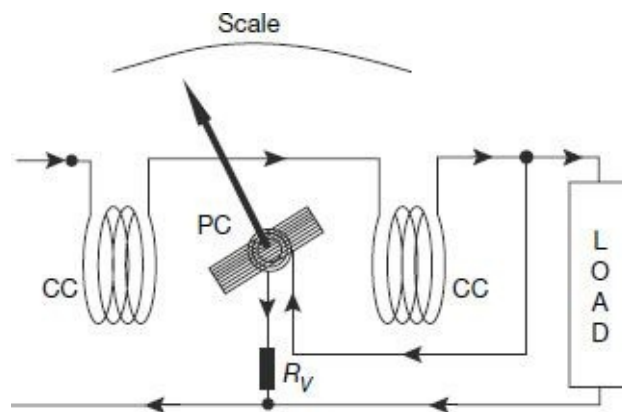

Figure 7.9 Schematic of electrodynamicometer-type wattmeter

Internal view of such an arrangement is shown in the photograph of [Figure 7.10](#).

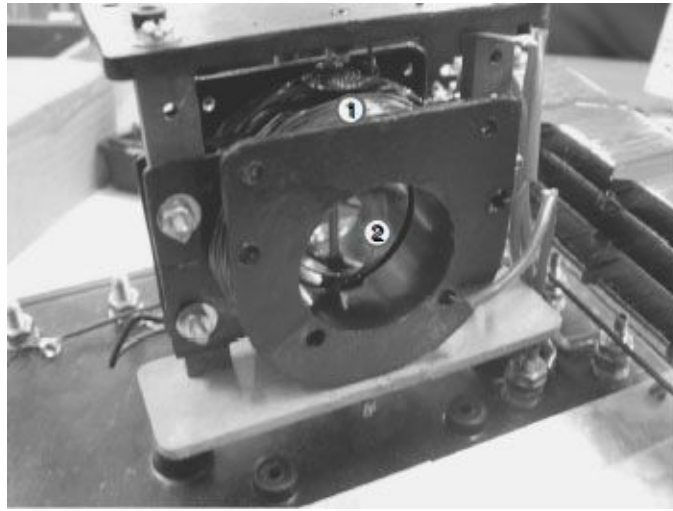

Figure 7.10 Internal photograph of electro-dynamometer-type wattmeter:(1) Fixed (current) coil (2) Moving (potential) coil

1. Fixed Coil System

Such an instrument has two coils connected in different ways to the same circuit of which power is to be measured. The *fixed coils* or the *field coils* are connected in series with the load so as to carry the same current as the load. The fixed coils are hence, termed as the *Current Coils (CC)* of the wattmeter. The main magnetic field is produced by these fixed coils. This coil is divided in two sections so as to provide more uniform magnetic field near the centre and to allow placement of the instrument moving shaft.

Fixed coils are usually wound with thick wires for carrying the main load current through them. Windings of the fixed coil is normally made of stranded conductors running together but, insulated from each other. All the strands are brought out to an external commutating terminator so that a number of current ranges of the instrument may be obtained by grouping them all in series, all in parallel, or in a series-parallel combination. Such stranding of the fixed coils also reduces Eddy-current loss in the conductors. Still higher current or voltage ranges, however, can be accommodated only through the use of instrument transformers.

Fixed coils are mounted rigidly with the coil supporting structures to prevent any small movement whatsoever and resulting field distortions. Mounting supports are made of ceramic, and not metal, so as not to disturb the magnetic field distribution.

2. Moving Coil System

The **moving coil** that is connected across the load carries a current proportional to the voltage. Since the moving coil carries a current proportional to the voltage, it is called the *voltage coil* or the *pressure coil* or simply *PC* of the wattmeter. The moving coil is entirely embraced by the pair of fixed coils. A high value **non-inductive resistance** is connected in series with the voltage coil to restrict the current through it to a small value, and also to ensure that voltage coil current remains as far as possible in phase with the load voltage.

The moving coil, made of fine wires, is wound either as a self-sustaining air-cored coil, or else wound on a nonmetallic former. A metallic former, otherwise would induce Eddy-currents in them under influence of the alternating field.

3. Movement and Restoring System

The moving, or voltage coil along with the pointer is mounted on an aluminum spindle in case jewel bearings are used to support the spindle. For higher sensitivity requirements, the moving coil may be suspended from a torsion head by a metallic suspension which serves as a lead to the coil. In other constructions, the coil may be suspended by a silk fibre together with a spiral spring which gives the required torsion. The phosphor-bronze springs are also used to lead current into and out of the moving coil. In any case, the torsion head with suspension, or the spring, also serves the purpose of providing the restoring torque to bring the pointer back to its initial position once measurement is over.

The moving, or voltage coil current must be limited to much low values keeping in mind the design requirements of the movement system. Current is lead to and out of the moving coil through two spiral springs. Current value in the moving coil is thus to be limited to values that can be safely carried by the springs without appreciable heating being caused.

4. Damping System

Damping in such instruments may be provided by small aluminum vanes attached at the bottom of the spindle. These vanes are made to move inside enclosed air chambers, thereby creating the damping torque. In other cases, the moving coil itself can be stitched on a thin sheet of mica, which acts as the damping vane while movements. Eddy-current damping, however, cannot be used with these instruments. This is due to the fact that any metallic element to be used for Eddy-current damping will interfere and distort the otherwise weak operating magnetic field. Moreover, introduction of any external permanent magnet for the purpose of Eddy-current damping will severely hamper the operating magnetic field.

5. Shielding System

The operating field produced by the fixed coils, is comparatively lower in electro-dynamometer-type instruments as compared to other type of instruments. In some cases, even the earth's magnetic field can pollute the measurement readings. It is thus essential to shield the electro-dynamometer-type instruments from effects of external magnetic fields. Enclosures of such instruments are thus made of alloys with high permeability to restrict penetration of external stray magnetic fields into the instrument.

7.4.2 Operation of Electro-dynamometer-type Wattmeter

The schematic operational circuit of an electro-dynamometer-type wattmeter being used for measurement of power in a circuit is shown in [Figure 7.11](#).

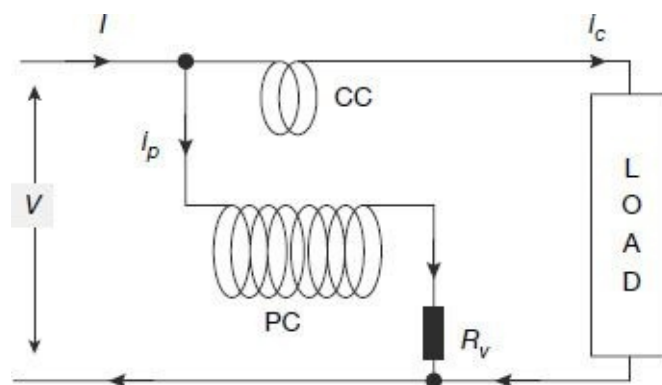

Figure 7.11 Operational circuit of electrodynameometer-type wattmeter

V = voltage to be measured (rms)

I = current to be measured (rms)

i_p = voltage (pressure) coil instantaneous current

i_c = current coil instantaneous current

R_V = external resistance connected with pressure coil

R_p = resistance of pressure coil circuit (PC resistance + R_V)

M = mutual inductance between current coil and pressure coil

θ = angle of deflection of the moving system

ω = angular frequency of supply in radians per second

ϕ = phase-angle lag of current I with respect to voltage V

As described in [Chapter 2](#), the instantaneous torque of the electrodynameometer wattmeter shown in [Figure 7.11](#) is given by

$$T_i = i_p i_c \frac{dM}{d\theta} \quad (7.9)$$

Instantaneous value of voltage across the pressure-coil circuit is

$$v_p = \sqrt{2} \times V \sin \omega t$$

If the pressure coil resistance can be assumed to be very high, the whole pressure coil can be assumed to be behaving like a resistance only. The current i_p in the pressure coil thus, can be assumed to be in phase with the voltage v_p , and its instantaneous value is

$$i_p = \frac{v_p}{R_p} = \sqrt{2} \times \frac{V}{R_p} \sin \omega t = \sqrt{2} \times I_p \sin \omega t$$

where $I_p = V/R_p$ is the rms value of current in pressure coil.

Assuming that the pressure-coil resistance is sufficiently high to prevent branching out of any portion of the supply current towards the pressure coil, the current coil current can be written as

$$i_c = \sqrt{2} \times I \sin(\omega t - \phi)$$

Thus, instantaneous torque from (7.9) can be written as

$$\begin{aligned}
T_i &= \sqrt{2} \times I_p \sin \omega t \times \sqrt{2} \times I \sin(\omega t - \varphi) \frac{dM}{d\theta} \\
&= 2I_p I \sin \omega t \sin(\omega t - \varphi) \frac{dM}{d\theta} \\
&= I_p I \{ \cos \varphi - \cos(2\omega t - \varphi) \} \frac{dM}{d\theta} \tag{7.10}
\end{aligned}$$

Presence of the term containing $2\omega t$, indicates the instantaneous torque as shown in (7.10) varies at twice the frequency of voltage and current.

Average deflecting torque over a complete cycle is

$$\begin{aligned}
T_d &= \frac{1}{T} \int_0^T T_i d\omega t = \frac{1}{2\pi} \int_0^{2\pi} I_p I \{ \cos \varphi - \cos(2\omega t - \varphi) \} \frac{dM}{d\theta} d\omega t \\
&= \frac{I_p I}{2\pi} [\omega t \cos \varphi]_0^{2\pi} \frac{dM}{d\theta} \\
&= I_p I \cos \varphi \frac{dM}{d\theta} \tag{7.11}
\end{aligned}$$

$$\begin{aligned}
&= \frac{V}{R_p} I \cos \varphi \frac{dM}{d\theta} \\
&= \frac{VI \cos \varphi}{R_p} \frac{dM}{d\theta} \tag{7.12}
\end{aligned}$$

With a spring constant K , the controlling torque provided by the spring for a final steady-state deflection of θ is given by

$$T_C = K\theta$$

Under steady-state condition, the average deflecting torque will be balanced by the controlling torque provided by the spring. Thus, at balanced condition $T_C = T_d$

$$\begin{aligned}
T_C &= T_d \\
K\theta &= \frac{VI \cos \varphi}{R_p} \frac{dM}{d\theta} \\
\theta &= \frac{VI \cos \varphi}{KR_p} \frac{dM}{d\theta} \\
\theta &= \left(K_1 \frac{dM}{d\theta} \right) P \tag{7.13}
\end{aligned}$$

where, P is the power to be measured and $K_1 = 1/KR_p$ is a constant.

Steady-state deflection θ is thus found to be an indication of the power P to be measured.

7.4.3 Shape of scale in Electrodynamometer-type Wattmeter

Steady-state deflection θ can be made proportional to the power P to be measured, i.e., the deflection will vary linearly with variation in power if the rate of change of mutual inductance is constant over the range of deflection. In other words, the scale of measurement will be uniform if the mutual inductance between the fixed and moving coils varies linearly with angle of deflection. Such a variation in mutual inductance can be achieved by careful design of the instrument. [Figure 7.12](#) shows the expected nature of

variation of mutual inductance between fixed and moving coils with respect to angle of deflection.

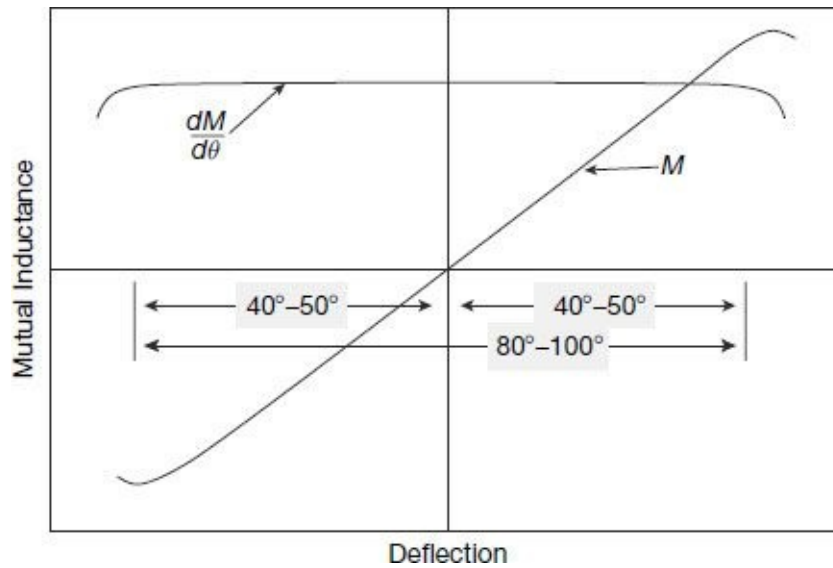

Figure 7.12 Variation of mutual inductance with deflection

By a suitable design, the mutual inductance between fixed and moving coils can be made to vary linearly with deflection angle over a range of 40° to 50° on either side of zero mutual inductance position, as shown in Figure 7.12. If the position of zero mutual inductance can be kept at the mid-scale, then the scale can be graduated to be uniform over 80° to 100° , which covers almost entire range of the scale.

7.4.4 Errors in Electrodynamometer-type Wattmeter

1. Error due to Pressure-Coil Inductance

It was assumed during the discussions so far that the pressure coil circuit is purely resistive. In reality, however, the pressure coil will have certain inductance along with resistance. This will introduce errors in measurement unless necessary compensations are taken care of. To have an estimate of such error, let us consider the following:

V = voltage applied to the pressure coil circuit (rms)

I = current in the current coil circuit (rms)

I_p = current in the voltage (pressure) coil circuit (rms)

r_p = resistance of pressure coil only

L = inductance of pressure coil

R_V = external resistance connected with pressure coil

R_p = resistance of pressure coil circuit (PC resistance + R_V)

Z_p = impedance of pressure coil circuit

M = mutual inductance between current coil and pressure coil

ω = angular frequency of supply in radian per second

ϕ = phase-angle lag of current I with respect to voltage V

Due to inherent inductance of the pressure coil circuit, the current and voltage in the pressure coil will no longer be in phase, rather the current through the pressure coil will lag the voltage across it by a certain angle given by

$$\alpha = \tan^{-1} \left(\frac{\omega L}{R_p} \right) = \tan^{-1} \left(\frac{\omega L}{r_p + R_v} \right)$$

As can be seen from [Figure 7.13](#), current through the pressure coil lags voltage across it by a phase-angle which is less than that between the current coil current and the pressure coil voltage.

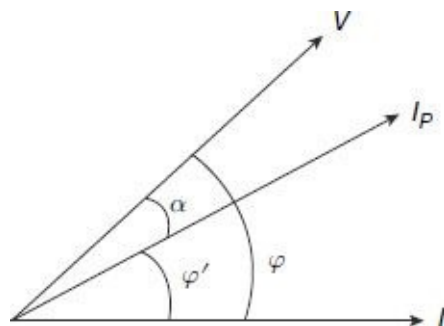

Figure 7.13 Wattmeter phasor diagram with pressure coil inductance

In such a case, phase-angle difference between the with pressure coil inductance pressure coil current and current coil current is

$$\phi' = \phi - \alpha$$

Following from (7.11), the wattmeter deflection will be

$$\theta' = \frac{I_p I}{K} \cos \phi' \cdot \frac{dM}{d\theta}$$

$$\theta' = \frac{V}{Z_p K} I \cos(\phi - \alpha) \cdot \frac{dM}{d\theta}$$

Relating to $R_p = Z_p \cos \alpha$ in the pressure coil circuit, the wattmeter deflection can be re-written as $VI \frac{dM}{d\theta}$

$$\theta' = \frac{VI}{R_p K} \cos \alpha \cdot \cos(\phi - \alpha) \cdot \frac{dM}{d\theta} \tag{7.14}$$

In the absence of inductance, $Z_p = R_p$ and $\alpha = 0$; wattmeter in that case will read true power, given by,

$$\theta = \frac{VI}{R_p K} \cos \phi \frac{dM}{d\theta} \tag{7.15}$$

Taking the ratio of true power indication to actual wattmeter reading, we get

$$\frac{\text{True power indication}}{\text{Actual wattmeter reading}} = \frac{\theta}{\theta'} = \frac{\frac{VI}{R_p K} \cos \phi \frac{dM}{d\theta}}{\frac{VI}{R_p K} \cos \alpha \cdot \cos(\phi - \alpha) \cdot \frac{dM}{d\theta}} = \frac{\cos \phi}{\cos \alpha \cdot \cos(\phi - \alpha)}$$

Thus, the correction factor can be identified as

$$CF = \frac{\cos \phi}{\cos \alpha \cdot \cos(\phi - \alpha)}$$

True power indication can thus be obtained from the actual wattmeter reading using the correction factor CF as

$$\text{True power indication} = CF \times \text{Actual wattmeter reading}$$

Thus, for lagging power factor loads,

$$\text{True power indication} = \frac{\cos \phi}{\cos \alpha \cdot \cos(\phi - \alpha)} \times \text{Actual wattmeter readings}$$

The above relations, along with [Figure 7.13](#) indicate that under lagging power factor loads, unless special precautions are taken, actual wattmeter reading will tend to display higher values as compared to true power consumed.

For leading power factor loads, however, the wattmeter phasor diagram will be as shown in [Figure 7.14](#).

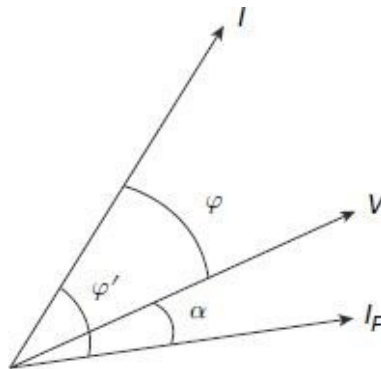

Figure 7.14 Wattmeter phasor diagram with pressure coil inductance during leading load

For leading power factor loads,

$$\text{True power indication} = \frac{\cos \phi}{\cos \alpha \cdot \cos(\phi + \alpha)} \times \text{Actual wattmeter readings}$$

The above relations, along with [Figure 7.13](#) indicate that under leading power factor loads, unless special precautions are taken, actual wattmeter reading will tend to display higher values as compared to true power consumed.

2. Compensation for Pressure Coil Inductance

A wattmeter can be compensated for pressure coil inductance by connecting a preset value of capacitance across a certain portion of the external resistance connected in series with the pressure coil, as shown in [Figure 7.15](#).

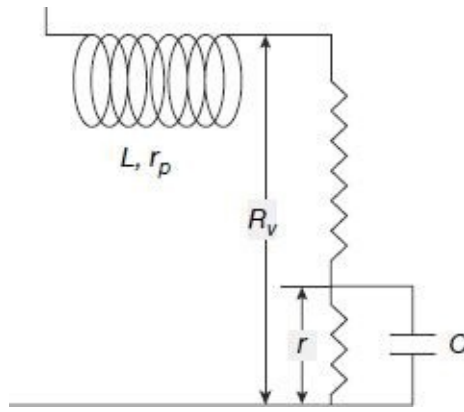

Figure 7.15 Compensation for pressure coil inductance

The total impedance of the circuit in such a case can be written as

$$Z_p = (r_p + R_v - r) + j\omega L + \frac{r - j\omega Cr^2}{1 + \omega^2 C^2 r^2}$$

To make the entire circuit behave as purely resistive, if we can design the circuit parameters in such a case that for power frequencies

$$\omega^2 C^2 r^2 \ll 1$$

Then we can re-write the total impedance of the pressure coil as

$$Z_p = (r_p + R_v - r) + j\omega L + r - j\omega Cr^2 = r_p + R_v + j\omega(L - Cr^2)$$

If by proper design, we can make $L = Cr^2$

Then, impedance = $r_p + R_v = R_p$

Thus error introduced due pressure coil inductance can be substantially eliminated.

3. Error due to Pressure Coil Capacitance

The voltage, or pressure coil circuit may have inherent capacitance in addition to inductance. This capacitance effect is mainly due to inter-turn capacitance of the winding and external series resistance. The effect of stray capacitance of the pressure coil is opposite to that due to inductance. Therefore, the wattmeter reads low on lagging power factors and high on leading power factors of the load. Actual reading of the wattmeter, thus, once again needs to be corrected by the corresponding correction factors to obtain the true reading. The effect of capacitance (as well as inductance) varies with variable frequency of the supply.

4. Error due to Connection

There are two alternate methods of connection of wattmeter to the circuit for measurement of power. These are shown in [Figure 7.16](#). In either of these connection modes, errors are introduced in measurement due power losses in pressure coil and current coil.

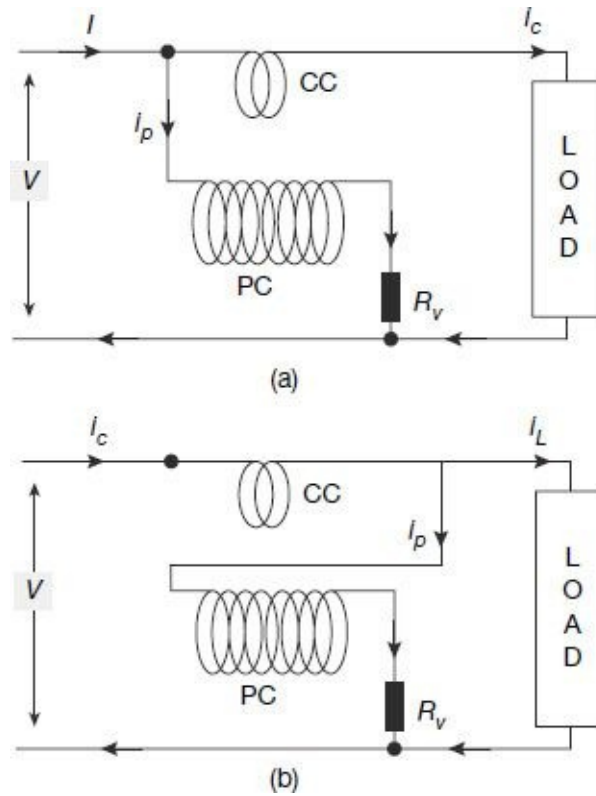

Figure 7.16 *Wattmeter connections*

In the connection of [Figure 7.16\(a\)](#), the pressure coil is connected across the supply, thus pressure coil measures the voltage across the load, plus the voltage drop across the current coil. Wattmeter reading in this case will thus include power loss in current coil as well, along with power consumed by the load.

$$\text{Wattmeter reading} = \text{Power consumed by load} + \text{Power loss in CC}$$

In the connection of [Figure 7.16\(b\)](#), the current coil is connected to the supply side; therefore, it carries load current plus the pressure coil current. Hence, wattmeter reading in this case includes, along with power consumed by the load, power loss in the pressure coil as well.

$$\text{Wattmeter reading} = \text{Power consumed by load} + \text{Power loss in PC}$$

In the case when load current is small, power loss in the current coil is small and hence the connection of [Figure 7.16\(a\)](#) will introduce comparatively less error in measurement.

On the other hand, when load current is large, current branching through the pressure coil is relatively small and error in measurement will be less if connection of [Figure 7.16\(b\)](#) is used.

Errors due to branching out of current through the pressure coil can be minimised by the use of compensating coil as schematically shown in [Figure 7.17](#).

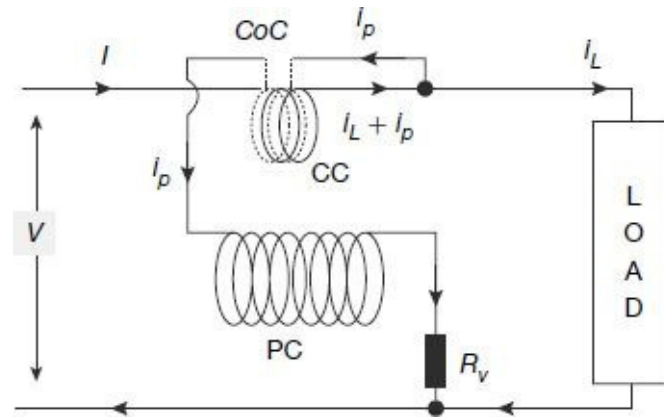

Figure 7.17 Schematic connection diagram of compensated wattmeter

In the compensated connection, the current coil consists of two windings, each winding having the same number of turns. The two windings are made as far as possible identical and coincident. One of the two windings (CC) is made of heavy wire that carries the load current plus the current for the pressure coil. The other winding (compensating coil-CoC) which is connected in series with the pressure coil, uses thin wire and carries only the current to the pressure coil. This current in the compensating coil is, however, in a direction opposite to the current in main current coil, creating a flux that opposes the main flux. The resultant magnetic field is thus due to the current coil only, effects of pressure coil current on the current coil flux mutually nullifying each other. Thus, error due to pressure coil current flowing in the current coil is cancelled out and the wattmeter indicates correct power.

5. Eddy-current Errors

Unless adequate precautions are adopted, Eddy-currents may be induced in metallic parts of the instrument and even within the thickness of the conductors by alternating magnetic field of the current coil. These Eddy-currents produce spurious magnetic fields of their own and distort the magnitude and phase of the main current coil magnetic field, thereby introducing error in measurement of power.

Error caused by Eddy-currents is not easy to estimate, and may become objectionable if metal parts are not carefully avoided from near the current coil. In fact, solid metal in coil supports and structural part should be kept to a minimum as far as practicable. Any metal that is used is kept away and is selected to have high resistivity so as to reduce Eddy-currents induced in it. Stranded conductors are recommended for the current coil to restrict generation of Eddy-current within the thickness of the conductor.

6. Stray Magnetic Field Errors

The operating field in electro-dynamometer-type instruments being weak, special care must be taken to protect these instruments from external magnetic fields. Hence, these instruments should be shielded against effects of stray magnetic fields. Laminated iron shields are used in portable laboratory instruments, while steel casings are provided as shields in switchboard mounted wattmeter. Precision wattmeters, however, are not provided with metals shields, for that will introduce errors due to Eddy-current, and also some dc error due to permanent magnetization of the metal shield under influence of external magnetic field. Such wattmeters are manufactured to have *astatic* system as shown in Figure

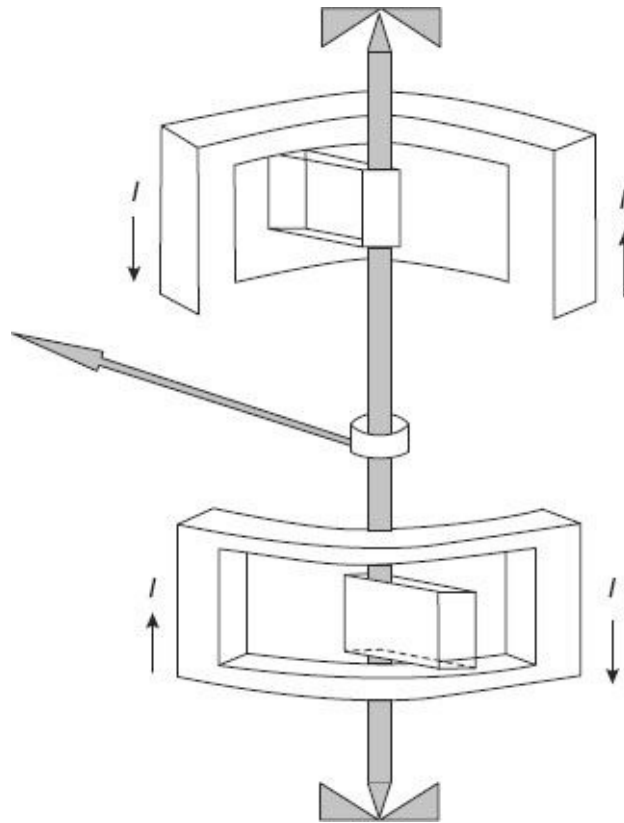

Figure 7.18 *Astatic systems for electro-dynamometer wattmeter*

Astatic electro-dynamometer instruments are constructed with two similar sets of fixed and moving coils mounted on the same shaft. The pair of fixed coils is so connected that their magnetic fields are in opposition. Similarly, the pair of moving coils is also connected to produce magnetic fields in opposite directions. This makes the deflecting torque acting on the two moving coils to be in the same direction. Deflection of the pointer is thus due to additive action of the two moving coils. However, since the two fields in the two pairs of fixed and moving coils are in opposition, any external uniform field will affect the two sets of pairs differently. The external field will reduce the field in one coil and will enhance the field in the other coil by identical amount. Therefore, the deflecting torque produced by one coil is increased and that by the other coil is reduced by an equal amount. This makes the net torque on account of the external magnetic field to zero.

7. Error Caused by Vibration of the Moving System

The instantaneous torque on the moving system varies cyclically at twice the frequency of the voltage and current (7.10). If any part of the moving system, such as the spring or the pointer has natural frequency close to that of torque pulsation, then accidental resonance may take place. In such a case, the moving system may vibrate with considerable amplitude. These vibrations may pose problems while noting the pointer position on the scale. These errors due to vibrations may be avoided by designing the moving elements to have natural frequencies much further away from twice the frequency of the supply voltage.

8. Temperature Errors

Temperature changes may affect accuracy of wattmeter by altering the coil resistances. Temperature may change due to change in room temperature or even due to heating effects in conductors with flow of current. Change in temperature also affects the spring stiffness,

thereby introducing error in the deflection process. High-precision instruments are fitted with temperature compensating resistors that tend to neutralise the effects of temperature variation.

Example 7.2

An electro-dynamometer-type wattmeter has a current coil with a resistance of 0.1Ω and a pressure coil with resistance of $6.5 \text{ k}\Omega$. Calculate the percentage errors while the meter is connected as (i) current coil to the load side, and (ii) pressure coil to the load side. The load is specified as (a) 12 A at 250 V with unity power factor, and (b) 12 A at 25 V with 0.4 lagging power factor.

Solution

(a) Load specified as 12 A at 250 V with unity power factor

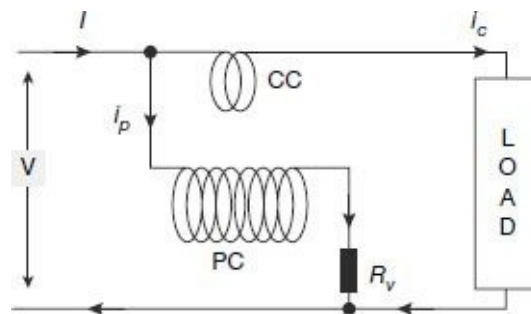

(i) Current coil (CC) on load side

$$\begin{aligned} \text{True power} &= VI \cos j \\ &= 250 \times 12 \times 1 \\ &= 3000 \text{ W} \end{aligned}$$

$$\begin{aligned} \text{Power lost in CC} &= I^2 \times r_C \text{ (where } r_C \text{ is the resistance of CC)} \\ &= 12^2 \times 0.1 \\ &= 14.4 \text{ W} \end{aligned}$$

The wattmeter will thus read total power = $3000 + 14.4 = 3014.4 \text{ W}$

$$\text{Hence, error in measurement} = \frac{14.4}{3000} \times 100\% = 0.48\%$$

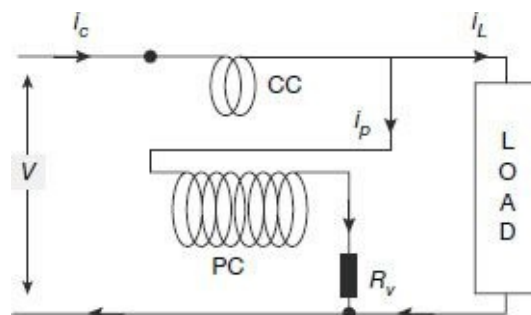

(ii) Pressure coil (CC) on load side

$$\text{True power} = VI \cos j$$

$$= 250 \times 12 \times 1$$

$$= 3000 \text{ W}$$

$$\text{Power lost in PC} = V^2/R_P \text{ (where } R_P \text{ is the resistance of PC)}$$

$$= 250^2/6500$$

$$= 9.6 \text{ W}$$

$$\text{The wattmeter will thus read total power} = 3000 + 9.6 = 3009.6 \text{ W}$$

$$\text{Hence, error in measurement} = \frac{9.6}{3000} \times 100\% = 0.32\%$$

(b) Load specified as 12 A at 250 V with 0.4 power factor

(i) Current coil (CC) on load side

$$\text{True power} = VI \cos j$$

$$= 250 \times 12 \times 0.4$$

$$= 1200 \text{ W}$$

$$\text{Power lost in CC} = I^2 \times r_C \text{ (where } r_C \text{ is the resistance of CC)}$$

$$= 12^2 \times 0.1$$

$$= 14.4 \text{ W}$$

$$\text{The wattmeter will thus read total power} = 1200 + 14.4 = 1214.4 \text{ W}$$

$$\text{Hence, error in measurement} = \frac{14.4}{1200} \times 100\% = 1.2\%$$

(ii) Pressure coil (PC) on load side

$$\text{True power} = 1200 \text{ W}$$

$$\text{Power lost in PC} = V^2/R_P \text{ (where } R_P \text{ is the resistance of PC)}$$

$$= 250^2/6500$$

$$= 9.6 \text{ W}$$

$$\text{The wattmeter will thus read total power} = 1200 + 9.6 = 1209.6 \text{ W}$$

$$\text{Hence, error in measurement} = \frac{9.6}{1200} \times 100\% = 0.8\%$$

An electrodynamicometer-type wattmeter is used for power

Example 7.3

measurement of a load at 100 V and 9 A at a power factor of 0.1 lagging. The pressure coil circuit has a resistance of 3000 Ω and inductance of 30 mH. Calculate the percentage error in wattmeter reading when the pressure coil is connected (a) on the load side, and (b) on the supply side. The current coil has a resistance of 0.1 Ω and negligible inductance. Assume 50 Hz supply frequency.

Solution

(a) Load specified as 9 A at 100 V with 0.1 power factor:

$$\begin{aligned}\text{True power} &= VI \cos \phi \\ &= 100 \times 9 \times 0.1 \\ &= 90 \text{ W}\end{aligned}$$

$$\text{Phase-angle } \phi = \cos^{-1}(0.1) = 1.471 \text{ rad}$$

Given, resistance of pressure coil circuit = 3000 Ω

and reactance of pressure coil circuit = $2\pi \times 50 \times 30 \times 10^{-3} = 9.42 \Omega$

$$\therefore \text{phase-angle of the pressure coil circuit } \alpha = \tan^{-1} \frac{9.42}{3000} = 0.00313 \text{ rad}$$

(i) Pressure coil connected on the load side

Following the expression (7.15) for actual power indication of the wattmeter in the presence of pressure coil inductance, the actual wattmeter reading is given by

$$\text{Actual wattmeter reading} = \frac{\text{True power indication}}{\cos \phi} \times \cos \alpha \cdot \cos(\phi - \alpha)$$

$$\text{Actual wattmeter reading} = \frac{90}{0.1} \times \cos(0.00313) \cdot \cos(1.471 - 0.00313) = 92.47 \text{ W}$$

$$\begin{aligned}\text{Power loss in wattmeter} &= \frac{V^2}{R_p} \\ &= \frac{100^2}{3000} \\ &= 3.33 \text{ W}\end{aligned}$$

$$\begin{aligned}\text{Total power indication of wattmeter, taking power loss in PC into account as well is} \\ &= 92.47 + 3.33 \\ &= 95.8 \text{ W}\end{aligned}$$

$$\therefore \text{error in measurement} = \frac{95.8 - 90}{90} \times 100\% = 6.44\%$$

(ii) Current coil connected on the load side

True power remains = 90 W

The CC gets in series with the load, and power loss in CC gets included in the total power.

$$\text{Total power} = 90 + I^2 \times r_C = 90 + 9^2 \times 0.1 = 98.1 \text{ W}$$

$$\text{Load impedance } Z = V/I = 100/9 = 11.1 \Omega$$

$$\text{Load resistance } R_L = Z \times \cos \varphi = 11.1 \times 0.1 = 1.11 \Omega$$

$$\text{Load reactance } X_L = Z \times \sin \varphi = 11.1 \times 0.995 = 11.05 \Omega$$

Total load resistance including CC resistance

$$R_L \phi = 1.11 + 0.1 = 11.21 \Omega$$

Since CC has no inductance, total load reactance including CC reactance = $X_L \phi = 11.05 + 0 = 11.05 \Omega$

Total load power factor including CC

$$\cos \varphi' = \cos (\tan^{-1}(11.05/1.21)) = 1.462 \text{ rad}$$

$$\text{Actual wattmeter reading} = \frac{\text{Total power indication}}{\cos \varphi'} \times \cos \alpha \cdot \cos(\varphi' - \alpha)$$

$$\text{Actual wattmeter reading} = \frac{98.1}{0.109} \times \cos(0.00313) \cdot \cos(1.462 - 0.00313) = 100.52 \text{ W}$$

$$\therefore \text{error in measurement} = \frac{100.52 - 90}{90} \times 100\% = 11.69\%$$

Larger error in case (ii) as compared to case (i) confirms the fact that low power factor power measurements should not have the CC of wattmeter connected to the load side.

7.5

INDUCTION-TYPE WATTMETER

Induction-type wattmeters work in similar principles as for induction type ammeters and voltmeters previously discussed in [Chapter 2](#). Induction-type wattmeters, however, following the very basic principles of mutual induction, can only be used for measurement of ac power, in contrast to electrodynamicometer type wattmeters that can be used for power measurements in both ac and dc circuits. Induction type wattmeters, in contradiction to electrodynamicometer-type wattmeters, can be used only with circuits having relatively steady values of frequency and voltage.

7.5.1 Construction of Induction-type Wattmeter

Schematic diagram displaying the basic constructional features of an induction-type wattmeter is shown in [Figure 7.19](#).

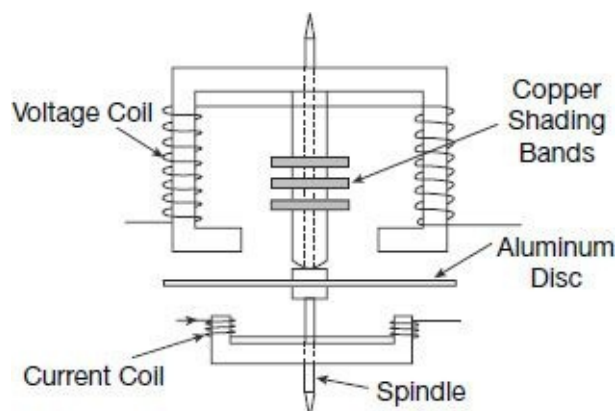

Figure 7.19 *Constructional details of induction-type wattmeter*

Induction-type wattmeters have two laminated iron-core electromagnets. One of the electromagnets is excited by the load current, and the other by a current proportional to the voltage of the circuit in which the power is to be measured. The upper magnet in [Figure 7.19](#), which is connected across the voltage to be measured, is named as the *shunt* magnet, whereas the other electromagnet connected in series with the load to carry load current is called the *series* magnet. A thin aluminum disc, mounted in the space between the two magnets is acted upon by a combined effect of fluxes coming out of these two electromagnets. In ac circuits, interaction of these changing fluxes will induce Eddy-current within the aluminum disc.

The two voltage coils, connected in series, are wound in such a way that both of them send flux through the central limb. Copper shading bands fitted on the central limb of the shunt magnet makes the flux coming out of the magnet lag behind the applied voltage by 90° .

The series magnet houses two small current coils in series. These are wound in a way that the fluxes they create within the core of the magnet are in the same direction.

7.5.2 Operation of Induction-type Wattmeter

A simplified phasor diagram for describing the theory of operation of induction-type wattmeter is shown in [Figure 7.20](#).

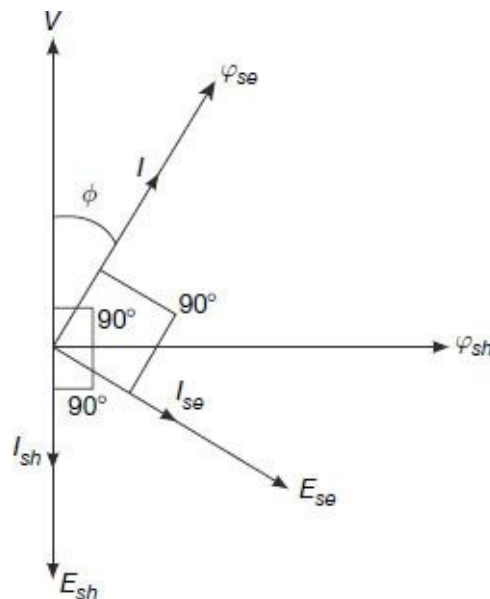

Figure 7.20 *Phasor diagram for induction-type wattmeter*

V = voltage to be measured

I = current to be measured

ϕ = phase-angle lag of current I with respect to voltage V

ϕ_{sh} = flux of the shunt magnet

ϕ_{se} = flux of the series magnet

E_{sh} = eddy emf induced in the disc by the flux ϕ_{sh} of shunt magnet

I_{sh} = eddy-current flowing in the disc due to and in phase with E_{sh} (neglecting inductance of the Eddy-current path)

E_{se} = eddy emf induced in the disc by the flux ϕ_{se} of series magnet

I_{se} = eddy-current flowing in the disc due to and in phase with E_{se} (neglecting inductance of the Eddy-current path)

Z = impedance of the Eddy-current path

ω = angular frequency of supply in radians per second

T_d = average torque acting on the disc

The shunt magnet flux ϕ_{sh} is made to lag behind the applied voltage (V) by 90° . This is achieved by the use of copper shading rings. On the other hand, the series magnet flux ϕ_{se} is in the same phase as the load current (I) through it.

Continuing from theories of induction-type instruments in [Chapter 2](#), the instantaneous torque acting on the aluminum disc is proportional to $(\phi_{sh} \cdot i_{se} - \phi_{se} \cdot i_{sh})$.

Let, instantaneous value the applied voltage is

$$v = V_m \sin \omega t$$

Then, the instantaneous current is given by

$$i = I_m \sin (\omega t - \phi)$$

The shunt magnet flux generated is

$$\phi_{sh} = k' \int v \cdot dt = -k' \frac{V_m}{\omega} \cos \omega t \quad (7.16)$$

where k' is a constant and the minus (-) sign indicating the fact the flux ϕ_{sh} lags behind the voltage by 90° .

The series magnet flux generated is

$$\phi_{se} = k I_m \sin(\omega t - \phi) \quad (7.17)$$

where k is another constant.

The eddy emf induced in the disc due to the shunt magnet flux is

$$E_{sh} = -\frac{d\phi_{sh}}{dt} = -k'V_m \sin\omega t$$

The resultant eddy-current flowing in the disc is

$$I_{sh} = -\frac{k'V_m}{Z} \sin(\omega t - \alpha) \quad (7.18)$$

where α is the phase-angle of the eddy path impedance (Z).

Similarly, the eddy emf induced in the disc due to the series magnet flux is

$$E_{se} = -\frac{d\phi_{se}}{dt} = -kI_m \omega \cos(\omega t - \phi) a$$

The resultant Eddy-current flowing in the disc is

$$I_{se} = -\frac{kI_m}{Z} \omega \cos(\omega t - \phi - \alpha) \quad (7.19)$$

The instantaneous deflecting torque (T) acting on the disc can now be calculated as

$$T = \frac{kk'}{Z} V_m I_m [\cos\omega t \cos(\omega t - \phi - \alpha) + \sin(\omega t - \phi) \sin(\omega t - \alpha)] \quad (7.20)$$

The average torque acting on the disc is thus

$$\begin{aligned} T_d &= \frac{1}{2\pi} \int_0^{2\pi} \frac{kk'}{Z} V_m I_m [\cos\omega t \cos(\omega t - \phi - \alpha) + \sin(\omega t - \phi) \sin(\omega t - \alpha)] dt \\ &= \frac{kk'}{Z} V_m I_m \frac{1}{2} [\cos(\phi + \alpha) + \cos(\phi - \alpha)] \\ &= \frac{kk'}{Z} V_m I_m \cos\alpha \cos\phi \\ &= \left(\frac{2kk'}{Z} \cos\alpha \right) VI \cos\phi \end{aligned} \quad (7.21)$$

where, V and I are rms values of voltage and current. Average torque on the instrument is thus found to be proportional to the power in the circuit.

7.5.3 Differences Between Dynamometer Wattmeter and Induction-type Wattmeters

Though both electro-dynamometer and induction type wattmeters can be used for measurement of power, following are the differences between the two.

Dynamometer Type Wattmeter	Induction Type Wattmeter
Schematic of electro-dynamometer type wattmeter	Schematic of induction type wattmeter
Current coil split in two parts, but a single pressure coil	Both current and pressure coils split in two parts each, placed on each of two arms of the two magnets
Pressure coil is the moving coil	None of the coils are moving, rather there is an aluminum disc placed between the two electromagnets, that moves
Pointer is attached with the moving (pressure) coil	Pointer is attached with the aluminum disc
Can be used for measurement of power both in AC as well as DC circuits	Can only be used for measurement of power in AC circuits
Fluid friction damping is used	Eddy current damping is used
Both the coils are air-cored	Both the coils are mounted on laminated iron core
Can be used in circuits even with fluctuating frequency and voltage	Can be used only with circuits having relatively steady values of frequency and voltage

7.6

POWER MEASUREMENT IN POLYPHASE SYSTEMS

Blondel's Theorem

The theorem states that 'in an n -phase network, the total power can be obtained by taking summation of the n wattmeters so connected that current elements of the wattmeters are each in one of the n lines and the corresponding voltage element is connected between that line and a common point'.

Consider the case of measuring power using three wattmeters in a 3-phase, 3-wire system as shown

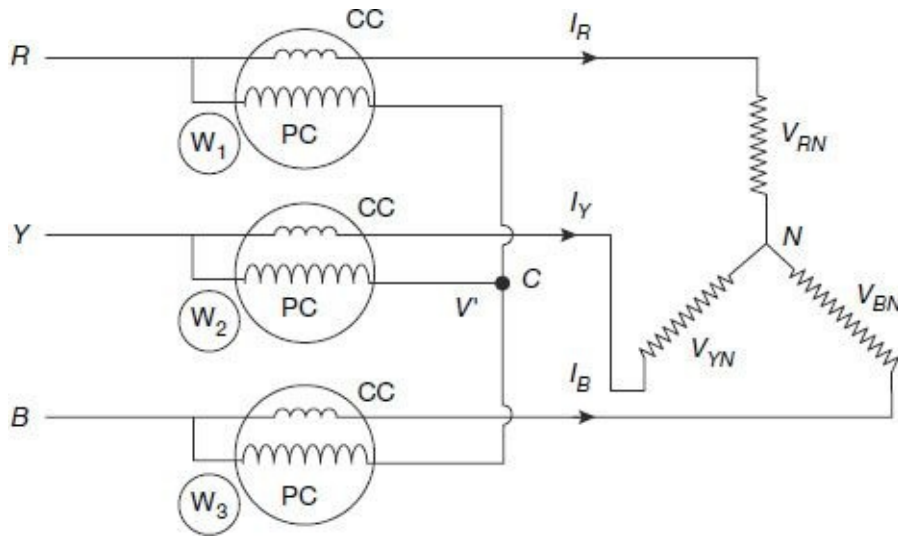

Figure 7.21 Power measurement in a 3-phase 3-wire system

Current coils of the three wattmeters, W_1 , W_2 and W_3 are connected to the three lines R , Y , and B . Potential coils of the three wattmeters are connected to the common point C . The potential at the point C may be different from the neutral point (N) potential of load.

Power consumed by the load

$$P = V_{RN} \times I_R + V_{YN} \times I_Y + V_{BN} \times I_B \quad (7.22)$$

Reading of wattmeter W_1 , $P_1 = V_{RC} \times I_R$

Reading of wattmeter W_2 , $P_2 = V_{YC} \times I_Y$

Reading of wattmeter W_3 , $P_3 = V_{BC} \times I_B$

Now, if the voltage difference between the nodes C and N is taken as $V_{CN} = V_C - V_N$, then we can have

$$V_{RN} = V_R - V_N = V_R - V_C + V_C - V_N = V_{RC} + V_{CN}$$

$$V_{YN} = V_Y - V_N = V_Y - V_C + V_C - V_N = V_{YC} + V_{CN}$$

$$V_{BN} = V_B - V_N = V_B - V_C + V_C - V_N = V_{BC} + V_{CN}$$

Sum of the three wattmeter readings can now be combined as

$$\begin{aligned} P_1 + P_2 + P_3 &= (V_{RN} - V_{CN}) \times I_R + (V_{YN} - V_{CN}) \times I_Y + (V_{BN} - V_{CN}) \times I_B \\ &= V_{RN} \times I_R + V_{YN} \times I_Y + V_{BN} \times I_B - V_{CN} (I_R + I_Y + I_B) \end{aligned}$$

Applying Kirchhoff's current law at node N , $(I_R + I_Y + I_B) = 0$

Thus, sum of wattmeter readings,

$$P_1 + P_2 + P_3 = V_{RN} \times I_R + V_{YN} \times I_Y + V_{BN} \times I_B \quad (7.23)$$

Comparing with Eq. (7.22), it is observed that sum of the three individual wattmeter readings indicate the total power consumed by the load.

7.7.1 Three-Wattmeter Method

1. Three-Phase Three-Wire Systems

Measurement of power in a 3-phase 3-wire system using three wattmeters has already been described in Section 7.6.1.

2. Three-Phase Four-Wire Systems

Wattmeter connections for measurement of power in a 3-phase 4-wire system are shown in Figure 7.22.

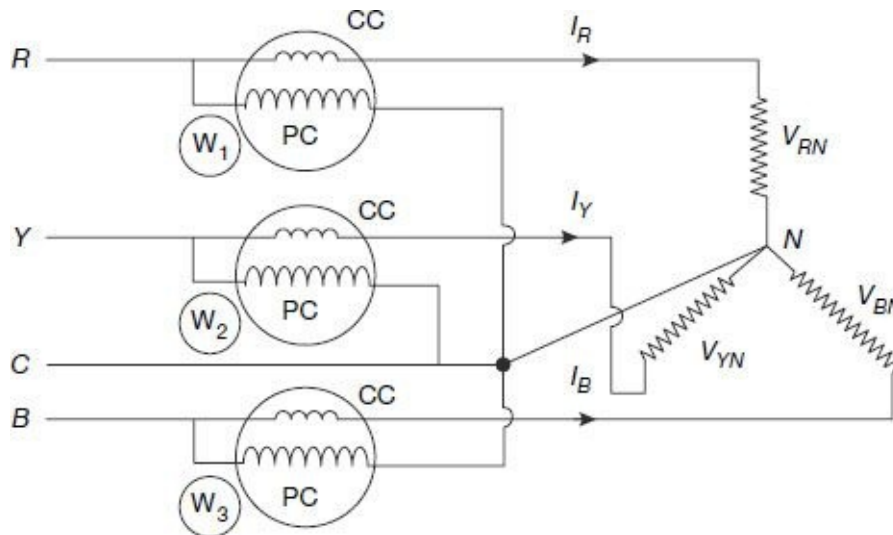

Figure 7.22 Power measurement in 3-phase 4-wire system

In this case, the common point of the three pressure coils coincides with the neutral N of the system. Voltage across each potential coil is thus, effectively the per-phase voltages of the corresponding phases. Current through current coils of the three wattmeters are nothing but the phase currents of the corresponding phases.

Sum of the three wattmeter readings in such a case will be

$$P_1 + P_2 + P_3 = V_{RN} \times I_R + V_{YN} \times I_Y + V_{BN} \times I_B$$

This is exactly the same as the power consumed by the load.

Hence, summation of the three wattmeter readings display the total power consumed by the load.

7.7.2 Two-Wattmeter Method

This is the most common method of measuring three-phase power. It is particularly useful when the load is unbalanced.

1. Star-Connected System

The connections for measurement of power in the case of a star-connected three-phase load are shown

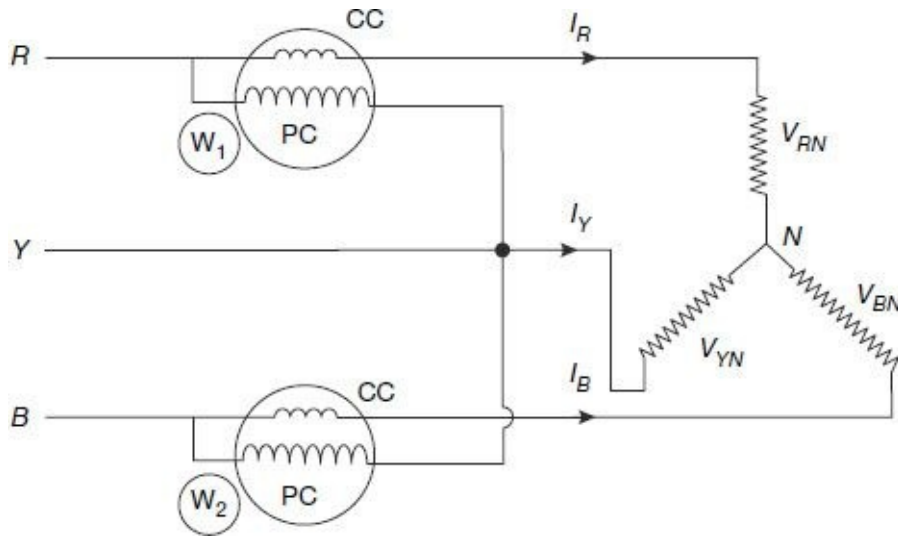

Figure 7.23 Two-wattmeter method for star-connected load

The current coils of the wattmeters are connected in lines R and B , and their voltage coils are connected between lines R and Y , and B and Y respectively.

Power consumed by the load

$$P = V_{RN} \times I_R + V_{YN} \times I_Y + V_{BN} \times I_B \quad (7.24)$$

Reading of wattmeter W_1 , $P_1 = V_{RY} \times I_R = (V_{RN} - V_{YN}) \times I_R$

Reading of wattmeter W_2 , $P_2 = V_{BY} \times I_B = (V_{BN} - V_{YN}) \times I_B$

Summation of the two wattmeter readings:

$$\begin{aligned} &= P_1 + P_2 = (V_{RN} - V_{YN}) \times I_R + (V_{BN} - V_{YN}) \times I_B \\ &= V_{RN} \times I_R + V_{BN} \times I_B - V_{YN} \times (I_R + I_B) \end{aligned} \quad (7.25)$$

From Kirchhoff's law, summation of currents at node N must be zero, i.e.,

$$I_R + I_Y + I_B = 0$$

or $I_R + I_B = -I_Y$

Thus, from Eq. (7.25), we can re-write,

$$P_1 + P_2 = V_{RN} \times I_R + V_{YN} \times I_Y + V_{BN} \times I_B \quad (7.26)$$

It can thus, be concluded that sum of the two wattmeter readings is equal to the total power consumed by the load. This is irrespective of fact whether the load is balanced or not.

2. Delta-Connected System

Two wattmeters can also be used for measurement of total power in a three-phase delta-connected system. The connections in the case of a delta-connected three-phase load are shown in [Figure 7.24](#).

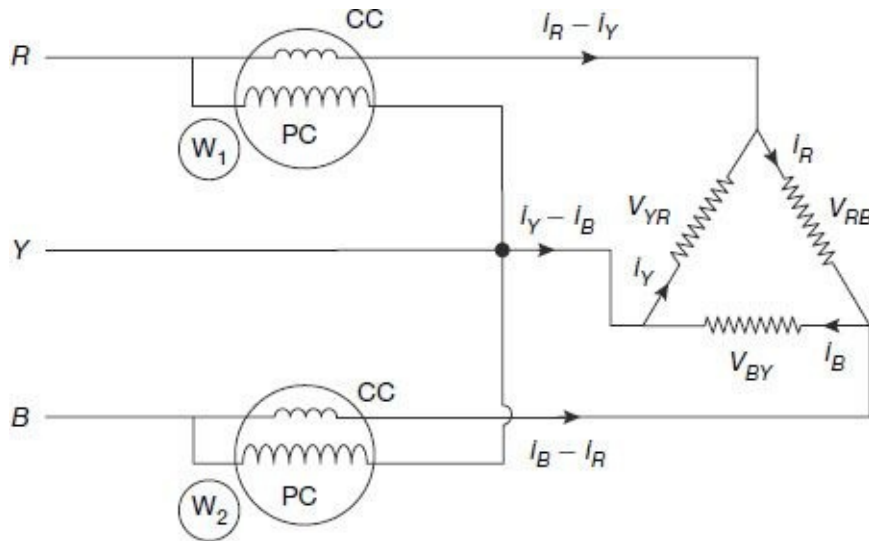

Figure 7.24 Two-wattmeter method for delta-connected load

The current coils of the wattmeters are connected in lines R and B , and their voltage coils are connected between lines R and Y , and B and Y respectively.

Power consumed by the load

$$P = V_{RB} \times i_R + V_{YR} \times i_Y + V_{BY} \times i_B \quad (7.27)$$

Reading of wattmeter W_1 , $P_1 = -V_{YR} \times (i_R - i_Y)$

Reading of wattmeter W_2 , $P_2 = V_{BY} \times (i_B - i_R)$

Summation of the two-wattmeter readings:

$$\begin{aligned} &= P_1 + P_2 = -V_{YR} \times (i_R - i_Y) + V_{BY} \times (i_B - i_R) \\ &= V_{YR} \times i_Y + V_{BY} \times i_B - i_R \times (V_{YR} + V_{BY}) \end{aligned} \quad (7.28)$$

From Kirchhoff's voltage law, summation of voltage drops across a closed loop is zero, i.e.,

$$V_{YR} + V_{BY} + V_{RB} = 0$$

or
$$V_{YR} + V_{BY} = -V_{RB}$$

Thus, from Eq. (7.28) we can re-write,

$$P_1 + P_2 = V_{YR} \times i_Y + V_{BY} \times i_B + V_{RB} \times i_R \quad (7.29)$$

Therefore, sum of the two wattmeter readings is equal to the total power consumed by the load. This is once again, irrespective of fact whether the load is balanced or not.

3. Effect of Power Factor on Wattmeter Readings

Phasor diagram for the star-connected load of [Figure 7.23](#) with a balanced load is shown in [Figure 7.25](#).

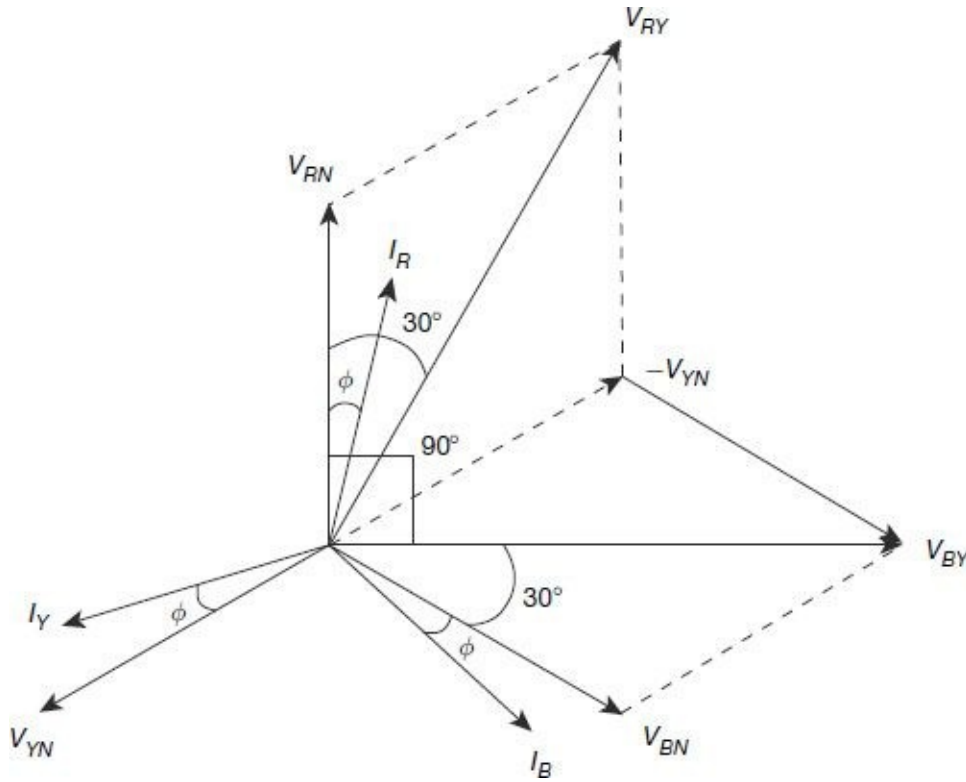

Figure 7.25 Phasor diagram for balanced three-phase star-connected load

Let, V_{RN} , V_{BN} , and V_{YN} are phase voltages and I_R , I_B , and I_Y are phase currents for the balanced three phase star-connected system under study.

For a balanced system, phase voltages, $V_{RN} = V_{BN} = V_{YN} = V$ (say)

And, phase currents, $I_R = I_B = I_Y = I$ (say)

For a star-connected system,

Line voltages $V_{RY} = V_{YB} = V_{BR} = \sqrt{3} V$

Line currents $I_R = I_B = I_Y = I$

Power factor = $\cos \phi$, where ϕ is the angle by which each of the phase currents lag the corresponding phase voltages.

Current through the CC of wattmeter W_1 is I_R and voltage across its potential coil is V_{RY} . The current I_R leads the voltage by V_{RY} an angle $(30^\circ - \phi)$, as shown in Figure 7.25.

\therefore reading of wattmeter W_1 is,

$$P_1 = V_{RY} \times I_R \cos(30^\circ - \phi) = \sqrt{3} VI \cos(30^\circ - \phi) \quad (7.30)$$

Current through the CC of wattmeter W_2 is I_B and voltage across its potential coil is V_{BY} . The current I_B lags the voltage by V_{BY} an angle $(30^\circ + \phi)$, as shown in Figure 7.25.

\therefore reading of wattmeter W_2 is,

$$P_2 = V_{BY} \times I_B \cos(30^\circ + \phi) = \sqrt{3} VI \cos(30^\circ + \phi) \quad (7.31)$$

Sum of these two-wattmeter readings:

$$P_1 + P_2 = \sqrt{3} VI \cos(30^\circ - \phi) + \sqrt{3} VI \cos(30^\circ + \phi) = 3 VI \cos \phi \quad (7.32)$$

This is the total power consumed by the load, adding together the three individual phases.

Thus, at any power factor, the total power consumed by the load will be, in any case, summation of the two wattmeter readings.

There is way to find out value of the load power factor, if unknown, by a few steps of manipulation.

Using Eq. (7.30) and Eq. (7.31), difference of the two wattmeter readings:

$$P_1 - P_2 = \sqrt{3} VI \cos(30^\circ - \phi) - \sqrt{3} VI \cos(30^\circ + \phi) = \sqrt{3} VI \sin \phi \quad (7.33)$$

Taking the ratio Eq. (7.33) to Eq. (7.32), one can have,

$$\text{or,} \quad \phi = \tan^{-1} \left(\sqrt{3} \frac{P_1 - P_2}{P_1 + P_2} \right) \quad (7.34)$$

Then, power factor, $\cos \phi = \cos \left[\tan^{-1} \left(\sqrt{3} \frac{P_1 - P_2}{P_1 + P_2} \right) \right]$

4. Unity Power Factor

With unity power factor, $\cos \phi = 1$, $\phi = 0$

$$\text{Total power } P = 3 VI \cos \phi = 3 VI \cos 0^\circ = 3 VI$$

Reading of wattmeter W_1 is,

$$P_1 = \sqrt{3} VI \cos(30^\circ - \phi) = \sqrt{3} VI \cos 30^\circ = \frac{3}{2} VI$$

Reading of wattmeter W_2 is,

$$P_2 = \sqrt{3} VI \cos(30^\circ + \phi) = \sqrt{3} VI \cos 30^\circ = \frac{3}{2} VI$$

Thus, summation of the two wattmeter readings $= P_1 + P_2 = \frac{3}{2} VI + \frac{3}{2} VI = 3 VI$, which is same as the total power.

Thus, at unity power factor, readings of the two wattmeters are equal; each wattmeter reads half the total power.

5. 0.5 Power Factor

With power factor, $\cos \phi = 0.5$, $\phi = 60^\circ$

$$\text{Total power } P = 3 VI \cos \phi = 3 VI \cos 60^\circ = \frac{3}{2} VI$$

$$P_1 = \sqrt{3} VI \cos(30^\circ - \phi) = \sqrt{3} VI \cos(30^\circ - 60^\circ) = \frac{3}{2} VI$$

$$P_2 = \sqrt{3} VI \cos(30^\circ + \phi) = \sqrt{3} VI \cos(30^\circ + 60^\circ) = 0$$

Thus, summation of the two wattmeter readings $= P_1 + P_2 = \frac{3}{2} VI + 0 = \frac{3}{2} VI$, which is same as the total power.

Therefore, at 0.5 power factor, one of the wattmeters reads zero, and the other reads total power.

6. Zero Power Factor

With power factor, $\cos \phi = 0$, $\phi = 90^\circ$

$$\text{Total power } P = 3VI \cos \phi = 3VI \cos 90^\circ = 0$$

$$P_1 = \sqrt{3} VI \cos(30^\circ - \phi) = \sqrt{3} VI \cos(30^\circ - 90^\circ) = \sqrt{3} VI \cos(-60^\circ) = \frac{\sqrt{3}}{2} VI$$

$$P_2 = \sqrt{3} VI \cos(30^\circ + \phi) = \sqrt{3} VI \cos(30^\circ + 90^\circ) = \sqrt{3} VI \cos(120^\circ) = -\frac{\sqrt{3}}{2} VI$$

Thus, summation of two-wattmeter readings $= P_1 + P_2 = \frac{\sqrt{3}}{2} VI - \frac{\sqrt{3}}{2} VI = 0$, which is same as the total power.

Therefore, at zero power factor, readings of the two wattmeters are equal but of opposite sign.

It should be noted from the above discussions that, at power factors below 0.5, one of the wattmeters would tend to give negative readings. [Figure 7.26](#) plots the nature of variations in the two wattmeter readings with changing power factor. However, in many cases, meter scales are not marked on the negative side, and hence negative readings cannot be recorded. In such a case, either the current or the pressure coil needs to be reversed; such that the meter reads along positive scale. This positive reading, however, should be taken with a negative sign for calculation of total power.

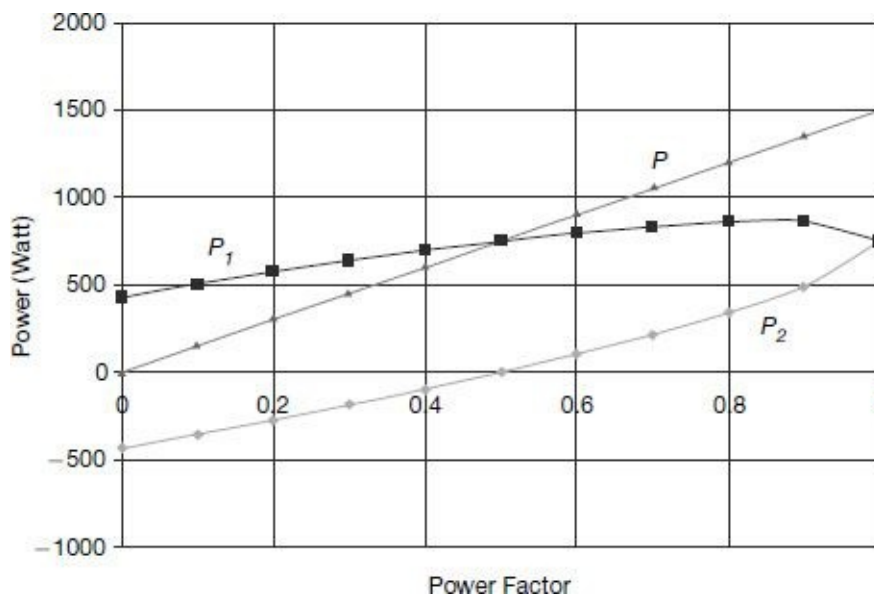

Figure 7.26 Variation of two wattmeter readings (P_1 and P_2) in comparison to the total power (P) with respect to changing power factor; load is assumed to be 5 A at 100 V

Example 7.4

Two wattmeters are connected to measure the power consumed by a 3-phase balanced load. One of the wattmeters read 1500 W and the other 700 W. Find power factor of the load, when (a) both the readings are positive, and (b) when the reading of the second wattmeter is obtained after reversing its current coil connection.

Solution

- (a) Given, $P_1 = 1500$ W and $P_2 = 700$ W
According to (7.34), power factor angle is given by

$$\phi = \tan^{-1} \left(\sqrt{3} \frac{P_1 - P_2}{P_1 + P_2} \right)$$

or,
$$\phi = \tan^{-1} \left(\sqrt{3} \frac{1500 - 700}{1500 + 700} \right) = 32.2^\circ$$

\therefore power factor = $\cos \phi = \cos 32.2^\circ = 0.846$

- (b) Given, $P_1 = 1500$ W and $P_2 = -700$ W

\therefore
$$\phi = \tan^{-1} \left(\sqrt{3} \frac{1500 - (-700)}{1500 + (-700)} \right) = 78.1^\circ$$

\therefore power factor = $\cos \phi = \cos 78.1^\circ = 0.21$

Example 7.5

Two wattmeters are connected to measure the power consumed by a 3-phase load with power factor 0.4. Total power consumed by the load, as indicated by the two wattmeters is 30 kW. Find the individual wattmeter readings.

Solution If P_1 and P_2 are the two individual wattmeter readings then according to the problem, $P_1 + P_2 = 30$ kW

Given, power factor, $\cos \phi = 0.4$

\therefore power factor angle $\phi = \cos^{-1} 0.4 = 66.4^\circ$

According to Eq. (7.3),

$$\phi = \tan^{-1} \left(\sqrt{3} \frac{P_1 - P_2}{P_1 + P_2} \right)$$

or,
$$\left(\sqrt{3} \frac{P_1 - P_2}{P_1 + P_2} \right) = \tan \phi = 2.29$$

Solving (i) and (ii), we get $P_1 = 34.85$ kW and $P_2 = -4.85$ kW

7.8

REACTIVE POWER MEASUREMENTS

If V and I are the rms values of the voltage and current in a single-phase circuit and Φ is the phase-angle difference between them, then the active power in the circuit is, $VI \cos \Phi$. The active power is obtained by multiplying the voltage by the component of current which is in same phase with the voltage (i.e., $I \cos \Phi$). The component of current which is 90° out of phase with the voltage (i.e., $I \sin \Phi$) is called the reactive component of current and the product $VI \sin \Phi$ is called the reactive power. Measurement of reactive power, along with active power is sometimes important, since the phase-angle Φ of the circuit can be obtained from the ratio (reactive power)/(active power).

$$\frac{\text{Reactive power}}{\text{Active power}} = \frac{VI \sin \phi}{VI \cos \phi} = \tan \phi$$

The same wattmeter that is used for measurement of active power can also be used for

measurement of reactive power with slight modifications in the connections. Observing the fact that $\sin \Phi = \cos (90^\circ - \Phi)$, the wattmeter may be so connected that the current coil carries the load current and the voltage coil should have a voltage that is 90° out of phase with the actual voltage of the circuit. Under these circumstances, the wattmeter will read

$$VI \cos (90^\circ - \Phi), \text{ or } VI \sin \Phi$$

For single-phase measurements, the pressure coil circuit may be made to behave as large inductive by inclusion of external inductors in series with it. This will cause the pressure coil current to lag behind the voltage by 90° , and thus the wattmeter will read

$$VI \cos (90^\circ - \Phi) = VI \sin \Phi = \text{Reactive power}$$

For measurement of reactive power in a circuit with a balanced 3-phase load, a single wattmeter may be used with suitable connections as shown in Figure 7.27, the corresponding phasor diagram is drawn in Figure 7.28.

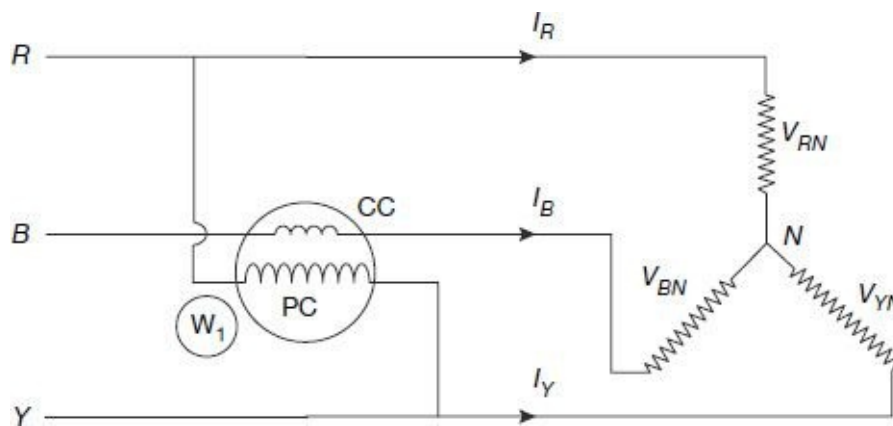

Figure 7.27 Connection diagram for reactive power measurement

The phasor I_B represents the current flowing through the CC of the wattmeter. The voltage applied across the voltage coil is the voltage difference between the lines R and Y, i.e., the difference between the phasors V_{RN} and V_{YN} , i.e., the phasor V_{RY} . The phase-angle between V_{RY} and $-V_{YN}$ is 30° , for the balanced system, and that between $-V_{YN}$ and V_{BN} is 60° . Thus, the total phase-angle difference between V_{RY} and V_{BN} is 90° , and the angle between V_{RY} and I_B is $(90^\circ + \Phi)$. The wattmeter will read

$$V_{RY} \times I_B \times \cos(90^\circ + \phi) = \sqrt{3} VI \cos(90^\circ + \phi) = -\sqrt{3} VI \sin \phi = -W_R$$

where, V is the per phase rms voltage and I is the line current of the system.

The total reactive power of the circuit is thus:

$$3 VI \sin \phi = -\sqrt{3} W_R$$

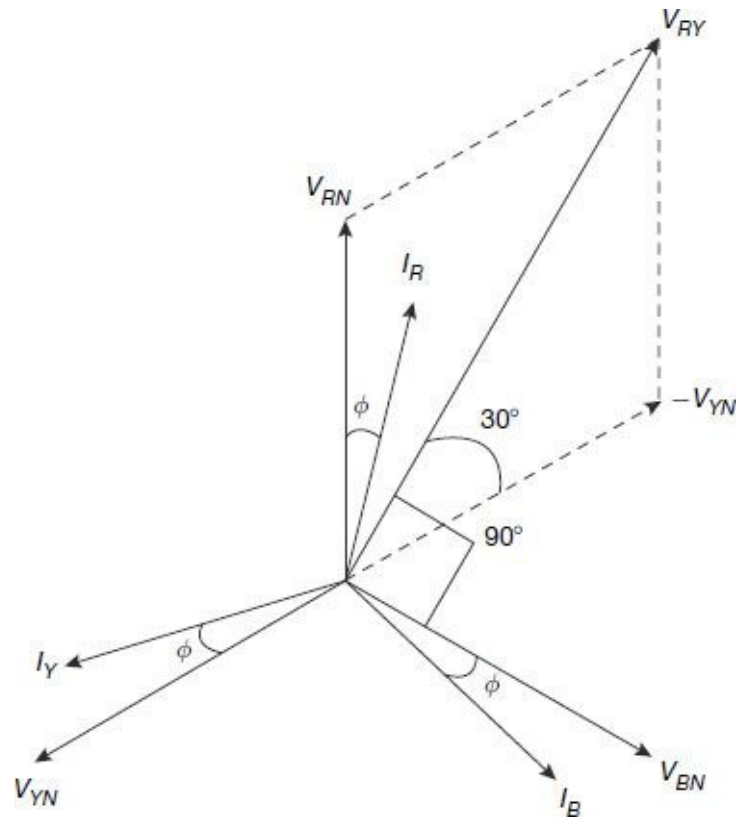

Figure 7.28 Phasor diagram for reactive power measurement

7.9

POWER MEASUREMENT WITH INSTRUMENT TRANSFORMERS

Power measurements in high-voltage, high-current circuits can be effectively done by the use of Potential Transformers (PT) and Current Transformers (CT) in conjunction with conventional wattmeters. By using a number of current transformers of different ratio for the current coil, and a number of potential transformers with different turns ratio for the voltage coil, the same wattmeter can be utilised for power measurements over a wide range.

Primary winding of the CT is connected in series with the load and the secondary winding is connected with the wattmeter current coil, often with an ammeter in between.

Primary winding of the PT is connected across the main power supply lines, and its secondary winding is connected in parallel with the wattmeter voltage coil.

The connections of a wattmeter when so used are shown in [Figure 7.29](#), an ammeter and a voltmeter is also connected in the circuit.

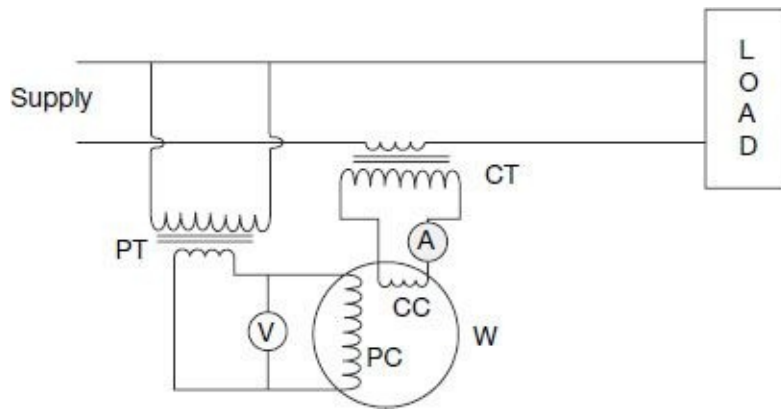

Figure 7.29 Power measurement using instrument transformers

PT and CT are, however, unless carefully designed and compensated, have inherent ratio and phase-angle errors. Ratio errors are more severe for ammeters and voltmeters, where phase-angle errors have more pronounced effects on power measurements. Unless properly compensated for, these can lead to substantial errors in power measurements.

Error introduced in power measurement due to ratio errors in PT and CT can be explained with the help of phasor diagrams of current and voltage in load and also in wattmeter coils, as shown in [Figure 7.30](#). [Figure 7.30\(a\)](#) refers to a load with lagging power factor, and [Figure 7.30\(b\)](#) to a load with leading power factor.

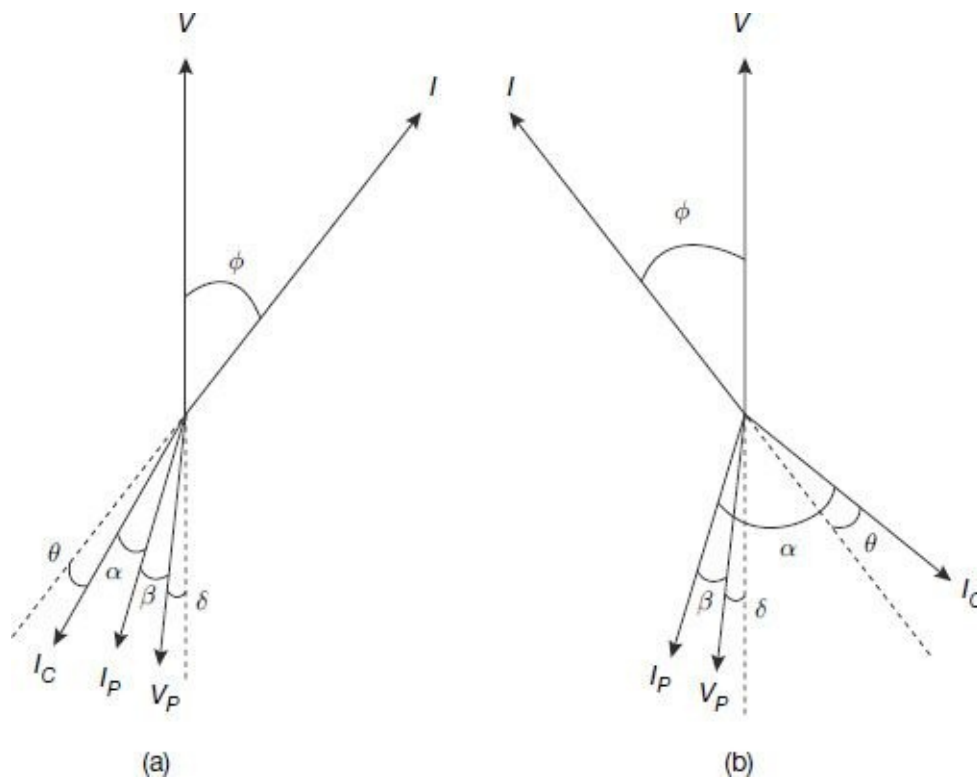

Figure 7.30 Phasor diagram showing phase-angle error during power measurement using instrument transformers for (a) lagging load, and (b) leading load

V = voltage across the load

I = load current

Φ = load phase-angle between V and I

V_P = voltage across secondary winding of PT Voltage across PC of Wattmeter

I_P = current through the PC

β = phase-angle lag between current I_P and voltage V_P due to inductance of the PC

I_C = secondary current of CT Current through CC of wattmeter

α = phase-angle difference the currents in CC and PC of wattmeter

δ = phase-angle error of PT, i.e., the deviation from secondary being exactly 180° out of phase with Respect to primary

θ = phase-angle error of CT, i.e., the deviation from secondary being exactly 180° out of phase with respect to primary

The Phasor shown with dotted lines are images of V and I with 180° phase shift.

1. Lagging Power Factor

In general, phase-angle (θ) of CT is positive, whereas phase-angle of PT (δ) may be positive or negative.

Thus, phase-angle of the load is $\Phi = \theta + \alpha + \beta \pm \delta$

2. Leading Power Factor

Phase-angle of the load is $\Phi = \alpha - \theta - \beta \pm \delta$

3. Correction Factors

For the time being, neglecting the ratio error, the correction factor that need to be incorporated for lagging power factor load is

$$K = \frac{\cos \phi}{\cos \beta \cdot \cos \alpha} = \frac{\cos \phi}{\cos \beta \cdot \cos(\phi - \theta - \beta \pm \delta)}$$

For leading power factor, the correction factor is

$$K = \frac{\cos \phi}{\cos \beta \cdot \cos \alpha} = \frac{\cos \phi}{\cos \beta \cdot \cos(\phi + \theta + \beta \pm \delta)}$$

Considering ratio errors for both PT and CT, the corresponding correction factors for ratio errors also need to be incorporated.

General expression for the power to be measured can now be written as

Power = K x Actual PT ratio x Actual CT ratio x Wattmeter reading

Example 7.6

A 110 V, 5 A wattmeter indicates 450 W, when used along with a PT with nominal ratio 110:1 and a CT with nominal ratio 25:1 respectively. Resistance and inductance of the wattmeter pressure coil circuit is 250 Ω and 7 mH

respectively. The ratio errors and phase-angles of PT and CT are +0.6%, -60', and -0.3% and +75' respectively. What is the true value of power being measured? The load phase-angle is 35° lagging, and the supply frequency is 50 Hz.

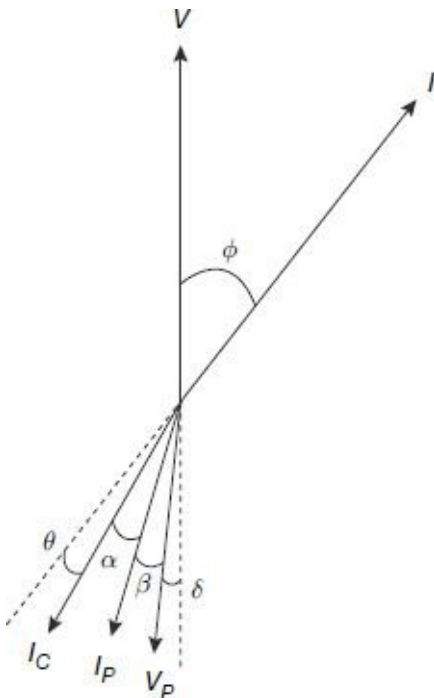

Solution Resistance of pressure coil circuit = 250 Ω

Reactance of pressure coil circuit

$$= 2\pi \times 50 \times 70 \times 10^{-3} = 2.2 \Omega$$

∴ phase-angle of pressure coil

$$\beta = \tan^{-1} \frac{2.2}{250} \approx 30'$$

Given,

Phase-angle of CT = $\theta = +75'$

Phase-angle of PT = $\delta = -60'$

Phase-angle of load = $\Phi = 35^\circ$

∴ phase-angle between wattmeter pressure coil current I_P and current coil current I_C is

$$\alpha = \Phi - \theta - \beta - \delta = 35^\circ - 75' - 60' - 30'$$

or, $\alpha = 32^\circ 15'$

Correction factor for phase-angle error,

$$K = \frac{\cos \phi}{\cos \beta \cdot \cos \alpha} = \frac{\cos 35^\circ}{\cos 30' \times \cos 32^\circ 15'} = 1.495$$

For PT or CT, the percentage ratio error is given by

$$\%E = \frac{K_n - K_a}{K_a} \times 100$$

where K_n = Nominal ratio and K_a = Actual ratio

$$\text{Thus, actual ratio } K_a = \frac{K_n \times 100}{100 + \%E}$$

$$\text{Thus, for CT, actual ratio} = \frac{25 \times 100}{100 - 0.3} = 25.08$$

$$\text{And, for PT, actual ratio} = \frac{110 \times 100}{100 + 0.6} = 109.34$$

$$\begin{aligned} \text{Hence, true power of load } P &= 1.495 \times 25.08 \times 109.34 \times 450 \times 10^{-3} \\ &= 1844.8 \text{ kW} \end{aligned}$$

EXERCISE

Objective-type Questions

- Power consumed by a simple dc circuit can be measured with the help of a single ammeter if
 - the load resistance is known
 - the supply voltage is known
 - both of (a) and (b) known
 - cannot be measured
- Power indicated while measuring power in a dc circuit using an ammeter and a voltmeter, when the voltmeter is connected to the load side, is
 - true power consumed by the load
 - power consumed by the load plus power lost in ammeter
 - power consumed by the load plus power lost in voltmeter
 - power consumed by load plus power lost in both ammeter and voltmeter
- In ammeter–voltmeter method for measurement of power in dc circuits, true power will be obtained with ammeter connected to the load side when
 - voltmeter has zero internal impedance
 - ammeter has zero internal impedance
 - ammeter has infinite internal impedance
 - voltmeter has infinite internal impedance
- Electrodynamometer-type wattmeters have a construction where
 - current coil is fixed
 - voltage coil is fixed
 - both voltage and current coils are movable
 - both voltage and current coils are fixed
- In electro-dynamometer-type wattmeters, current coil is made of two sections
 - to reduce power loss
 - to produce uniform magnetic field
 - to prevent Eddy-current loss
 - to reduce errors due to stray magnetic field
- In electro-dynamometer-type wattmeters, current coils carrying heavy currents are made of stranded wire
 - to reduce iron loss

- (b) to reduce Eddy-current loss in conductor
 - (c) to reduce hysteresis loss
 - (d) all of the above
7. In electrodynamicometer-type wattmeters, a high value noninductive resistance is connected in series with the pressure coil
- (a) to prevent overheating of the spring leading current in the pressure coil
 - (b) to restrict the current in the pressure coil
 - (c) to improve power factor of the pressure coil
 - (d) all of the above
8. In electrodynamicometer-type wattmeters, both current coil and pressure coil are preferably air-cored
- (a) to reduce effects of stray magnetic field
 - (b) to reduce Eddy-current losses under AC operation
 - (c) to increase the deflecting torque
 - (d) all of the above
9. In electrodynamicometer-type wattmeters, pressure coil inductance produce error which is
- (a) constant irrespective of load power factor
 - (b) higher at low power factors of load
 - (c) lower at low power factors of load
 - (d) same at lagging and leading power factors of load
10. When measuring power in a circuit with low current, the wattmeter current coil should be connected
- (a) to the load side
 - (b) to the source side
 - (c) anywhere, either load side or source side, does not matter
 - (d) in series with the load along with CT for current amplification
11. When measuring power in a circuit with high current
- (a) current coil should be connected to the load side
 - (b) pressure coil should be connected to the load side
 - (c) pressure coil should be connected to the source side
 - (d) the placement of pressure and current coils are immaterial
12. In induction-type wattmeters,
- (a) voltage coil is the moving coil
 - (b) current coil is the moving coil
 - (c) both are moving
 - (d) none are moving
13. Three wattmeters are used to measure power in a 3-phase balanced star connected load.
- (a) The reading will be higher when the neutral point is used as the common point for wattmeter pressure coils.
 - (b) The reading will be lower when the neutral point is used as the common point for wattmeter pressure coils.
 - (c) Wattmeter reading will remain unchanged irrespective whether the neutral is used for measurement or not.
 - (d) The three-wattmeter method cannot be used in systems with 4 wires.
14. Two wattmeters can be used to measure power in a
- (a) three-phase four-wire balanced load
 - (b) three-phase four-wire unbalanced load

- (c) three-phase three-wire unbalanced load
 (d) all of the above
15. In 2-wattmeter method for measurement of power in a star-connected 3 phase load, magnitude of the two wattmeter readings will be equal
- (a) at zero power factor
 (b) at unity power factor
 (c) at 0.5 power factor
 (d) readings of the two wattmeters will never be equal

Answers						
1. (a)	2. (c)	3. (b)	4. (a)	5. (b)	6. (b)	7. (d)
8. (b)	9. (a)	10. (a)	11. (b)	12. (d)	3. (c)	14. (d)
15. (b)						

Short-answer Questions

- Draw and label the different internal parts of an electro-dynamometer-type wattmeter. What are the special constructional features of the fixed and the moving coils in such an instrument?
- Discuss about the special shielding requirements and measures taken for shielding internal parts of an electro-dynamometer-type wattmeter against external stray magnetic fields.
- Draw and explain the operation of a compensated wattmeter used to reduce errors due to connection of pressure coil nearer to the load side as pertinent to electro-dynamometer-type wattmeters.
- Draw and explain the constructional features of an induction-type wattmeter used for measurement of power.
- Draw the schematic and derive how three-phase power consumed by a delta-connected load can be measured by two wattmeters.
- Explain how power factor of an unknown three-phase load can be estimated by using two wattmeters.
- Two wattmeters are connected to measure the power consumed by a 3-phase load with a power factor of 0.35. Total power consumed by the load, as indicated by the two wattmeters, is 70 kW. Find the individual wattmeter readings.
- With the help of suitable diagrams and sketches, explain how a single wattmeter can be used for measurement of reactive power in a 3-phase balanced system.
- Derive an expression for the correction factor necessary to be incorporated in wattmeter readings to rectify phase-angle error in instrument transformers while used for measurement of power.

Long-answer Questions

- Describe the constructional details of an electro-dynamometer-type wattmeter. Comment upon the shape of scale when spring control is used.
- Derive the expression for torque when an electro-dynamometer-type wattmeter is used for measurement of power in ac circuits. Why should the pressure-coil circuit be made highly resistive?
- List the different sources of error in electro-dynamometer-type wattmeters. Briefly discuss the error due to pressure coil inductance. How is this error compensated?
- Discuss the special features of damping systems in electro-dynamometer-type wattmeters.
 - An electro-dynamometer-type wattmeter is used for power measurement of a load at 200 V and 9 A at a power factor of 0.3 lagging. The pressure-coil circuit has a resistance of 4000 and inductance of 40 mH. Calculate the percentage error in the wattmeter reading when the pressure coil is connected (a) on the load side, and (b) on the supply side. The current coil has a resistance of 0.2 and negligible inductance. Assume 50 Hz supply frequency.
- A 250 V, 10 A electro-dynamometer wattmeter has resistance of current coil and potential coil of 0.5 and 12.5 k respectively. Find the percentage error due to the two possible connections: (a) pressure coil on load side, and (b) current coil on load side with unity power factor loads at 250 V with currents (i) 4A, and (ii) 8A. Neglect error due to pressure coil inductance.

6. Discuss in brief the constructional details of an induction-type wattmeter. Show how the deflecting torque in such instrument can be made proportional to the power in ac circuits.
7. (a) Draw the schematic and derive how three-phase power consumed by a star-connected load can be measured by two wattmeters.
(b) Two wattmeters are connected to measure the power consumed by a 3-phase balanced load. One of the wattmeters reads 1500 Ω and the other, 700 Ω . Calculate power and power factor of the load, when (a) both the readings are positive, and (b) when the reading of the second wattmeter is obtained after reversing its current coil connection.
8. A 110 V, 5 A range wattmeter is used along with instrument transformers to measure power consumed by a load at 6 KV taking 100 A at 0.5 lagging power factor. The instrument transformers have the following specifications:
PT: Nominal ratio = 80:1; Ratio error = +1.5%; Phase error = -2°
CT: Nominal ratio = 20:1; Ratio error = -1.0% ; Phase error = $+1^\circ$
Assuming wattmeter reads correctly, find the error in the indicated power due to instrument-transformer errors.

8.1

INTRODUCTION

Energy is the total power consumed over a time interval, that is $\text{Energy} = \text{Power} \times \text{Time}$. Generally, the process of measurement of energy is same as that for measurement of power except for the fact that the instrument used should not merely measure power or rate of consumption of energy, but must also take into account the time interval during which the power is being supplied.

The unit of energy can be expressed in terms of Joule or Watt-second or Watt-hour as per convenience. A larger unit that is most commonly used is kilowatt-hour (kWh), which is defined as the energy consumed when power is delivered at an average rate of 1 kilowatt for one hour. In commercial metering, this amount of 1 kilowatt-hour (kWh) energy is specified as 1 unit of energy.

Energy meters used for measurement of energy have moving systems that revolve continuously, unlike in indicating instruments where it deflects only through a fraction of a revolution. In energy meters, the speed of revolution is proportional to the power consumed. Thus, total number of revolutions made by the meter moving system over a given interval of time is proportional to the energy consumed. In this context, a term called meter constant, defined as the number of revolutions made per kWh, is used. Value of the meter constant is usually marked on the meter enclosure.

8.2

SINGLE-PHASE INDUCTION-TYPE ENERGY METER

Induction-type instruments are most commonly used as energy meters for measurement of energy in domestic and industrial ac circuits. Induction-type meters have lower friction and higher torque/weight ratio; they are inexpensive, yet reasonably accurate and can retain their accuracy over considerable range of loads and temperature.

8.2.1 Basic Theory of Induction-type Meters

In all induction-type instruments, two time-varying fluxes are created in the windings provided on the static part of the instrument. These fluxes are made to link with a metal disc or drum and produce emf therein. These emfs in turn, circulate eddy current on the body of the metal disc. Interaction of these fluxes and eddy currents produce torques that make the disc or drum to rotate. Schematic diagrams representing front and top views of such an instrument is shown in [Figure 8.1](#).

A thin aluminum disc free to rotate about its central axis is fitted with a spindle and placed below the two poles ϕ_1 and ϕ_2 . Fluxes ϕ_1 and ϕ_2 coming out of the two

electromagnets ϕ_1 and ϕ_2 link with the aluminum disc placed below. These fluxes are alternating in nature, and hence they induce emfs in the aluminum disc. These induced emfs will in turn produce eddy currents i_1 and i_2 on the disc, as shown in Figure 8.1. There are two sets of fluxes ϕ_1 and ϕ_2 , and two sets of currents i_1 and i_2 . Current i_1 interacts with flux ϕ_2 to produce a force F_1 and hence a torque T_{d1} on the disc. Similarly, current i_2 interacts with flux ϕ_1 to produce a force F_2 and hence a torque T_{d2} on the disc. Total torque is resultant of the torques T_{d1} and T_{d2} .

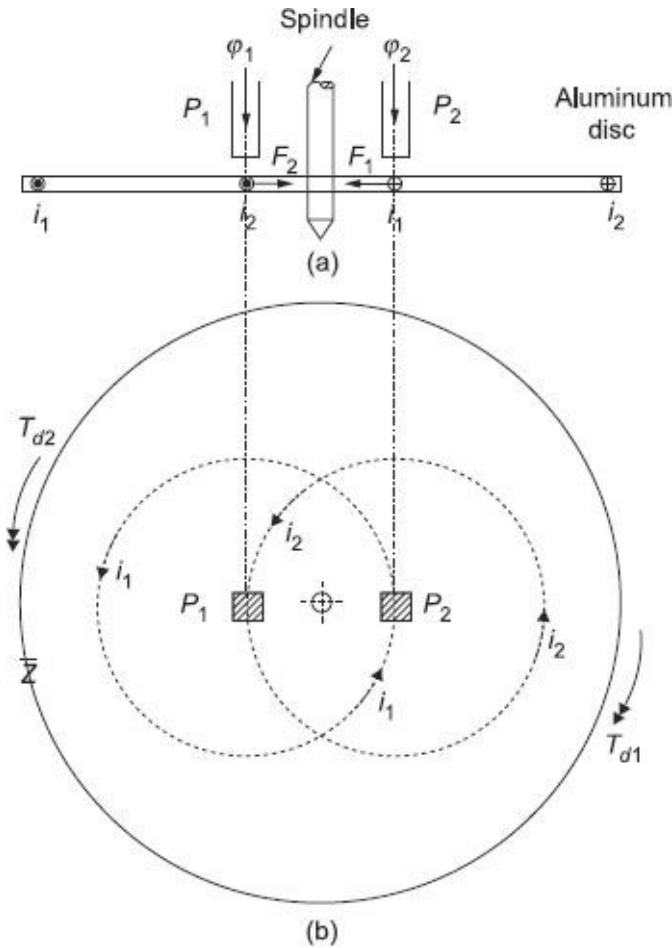

Figure 8.1 Working principle of induction-type instrument:
 (a) Front view (b) Top view

Let ϕ_1 and ϕ_2 are the instantaneous values of two fluxes having a phase difference of α between them. Therefore, we can write

$$\phi_1 = \phi_m \sin \omega t$$

and

$$\phi_2 = \phi_m \sin(\omega t - \alpha)$$

where, ϕ_{1m} and ϕ_{2m} are peak values of fluxes ϕ_1 and ϕ_2 respectively.

The flux ϕ_1 will produce an alternating emf in the disc, given by

$$e_1 = -\frac{d\phi_1}{dt} = -\frac{d}{dt}(\phi_{1m} \sin \omega t) = -\phi_{1m} \omega \cos \omega t$$

Similarly, the alternating emf produced in the disc due to the flux ϕ_2 is given by

$$e_2 = -\phi_{2m} \omega \cos(\omega t - \alpha)$$

If, \bar{Z} is considered to be the impedance of the aluminum disc with power factor β then

eddy current induced in the disc due to the emf e_1 can be expressed as

$$i_1 = \frac{e_1}{Z} = -\frac{\phi_{1m}\omega \cos(\omega t - \beta)}{Z}$$

Similarly, eddy current induced in the disc due to the emf e_2 is given by

$$i_2 = \frac{e_2}{Z} = -\frac{\phi_{2m}\omega \cos(\omega t - \alpha - \beta)}{Z}$$

Instantaneous torque developed in proportional to the product of instantaneous current and instantaneous flux are those that interact with each other to produce the torque in question.

\therefore instantaneous torque T_{d1} produced due to interaction of the current i_1 and flux ϕ_2 is given by

$$T_{d1} \propto \phi_2 i_1$$

Similarly, instantaneous torque T_{d2} produced due to interaction of the current i_2 and flux ϕ_1 is given by

$$T_{d2} \propto \phi_1 i_2$$

Total deflecting torque can thus be calculated as

$$\begin{aligned} T_d &\propto T_{d1} - T_{d2} \propto \phi_2 i_1 - \phi_1 i_2 \\ T_d &\propto \left[\begin{aligned} &\left\{ \phi_{2m} \sin(\omega t - \alpha) \right\} \times \left\{ -\frac{\phi_{1m}\omega \cos(\omega t - \beta)}{Z} \right\} \\ &- \left\{ \phi_{1m} \sin \omega t \right\} \times \left\{ -\frac{\phi_{2m}\omega \cos(\omega t - \alpha - \beta)}{Z} \right\} \end{aligned} \right] \\ T_d &\propto \frac{\phi_{1m}\phi_{2m}\omega}{Z} [\sin \omega t \cos(\omega t - \alpha - \beta) - \sin(\omega t - \alpha) \cos(\omega t - \beta)] \\ T_d &\propto \frac{\phi_{1m}\phi_{2m}\omega}{Z} \cdot \frac{1}{2} \left[\begin{aligned} &\sin(\omega t + \omega t - \alpha - \beta) + \sin(\omega t - \omega t + \alpha + \beta) \\ &- \sin(\omega t - \alpha + \omega t - \beta) - \sin(\omega t - \alpha - \omega t + \beta) \end{aligned} \right] \\ T_d &\propto \frac{\phi_{1m}\phi_{2m}\omega}{Z} \cdot \frac{1}{2} \left[\begin{aligned} &\sin(2\omega t - \alpha - \beta) + \sin(\alpha + \beta) \\ &- \sin(2\omega t - \alpha - \beta) - \sin(\beta - \alpha) \end{aligned} \right] \\ T_d &\propto \frac{\phi_{1m}\phi_{2m}\omega}{Z} \cdot \frac{1}{2} [\sin(\alpha + \beta) - \sin(\beta - \alpha)] \\ T_d &\propto \frac{\phi_{1m}\phi_{2m}\omega}{Z} \cdot \frac{1}{2} [\sin \alpha \cos \beta + \cos \alpha \sin \beta - \sin \beta \cos \alpha + \cos \beta \sin \alpha] \end{aligned}$$

$$T_d \propto \frac{\phi_{1m}\phi_{2m}\omega}{Z} \cdot \sin \alpha \cos \beta \quad (8.1)$$

The following two observations can be made from Eq. (8.1):

1. The torque is directly proportional to the power factor of the aluminum disc ($\cos \beta$). Thus, to increase the deflecting torque, the path of eddy current in the disc must be as resistive as possible, so that value of $\cos \beta$ is as high as possible.
2. The torque is directly proportional to $\sin \alpha$. Therefore, to have large deflecting

torque, the angle α between the two fluxes should preferably be as nearly as possible close to 90° .

8.2.2 Constructional Details of Induction-Type Energy Meter

Constructional details of an induction-type single-phase energy meter are schematically shown in Figure 8.2(a). The photograph of such an arrangement is shown in Figure 8.2(b).

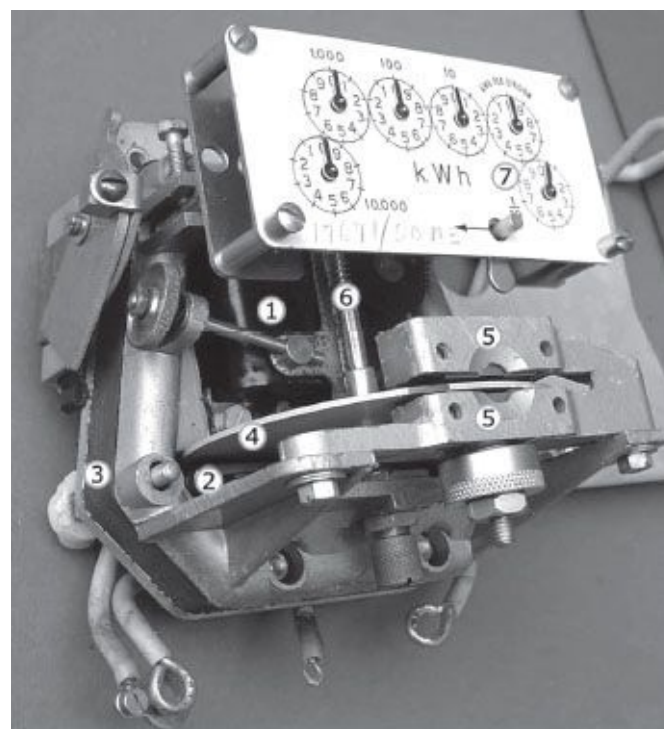
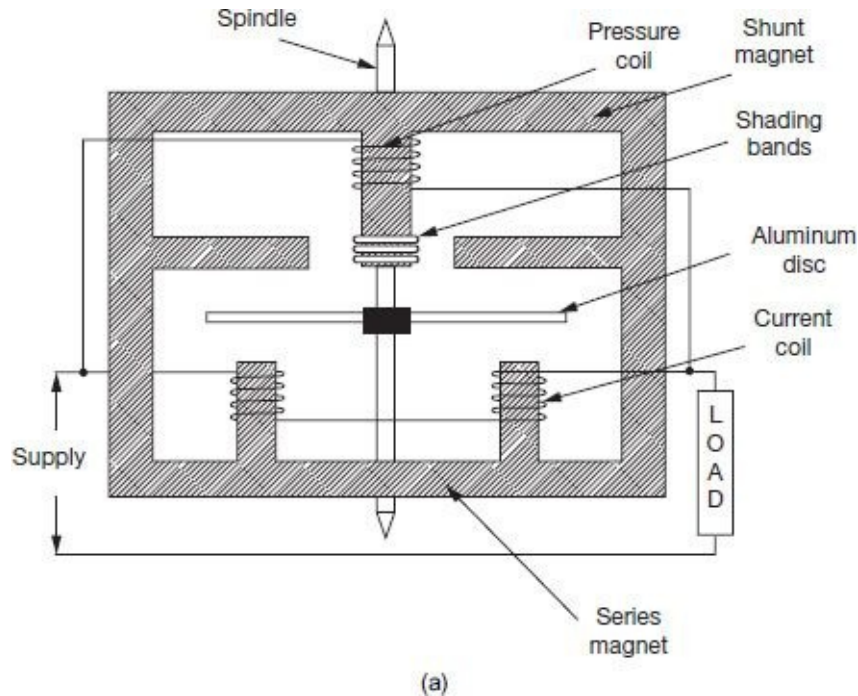

Figure 8.2 (a) Constructional details of induction-type single-phase energy meter

(b) Photograph of induction-type single-phase energy meter

(Courtesy, Creative Commons Attribution Share Alike 2.5)

1. **Volatage coil**—many turns of fine wire encased in plastic, connected in parallel with load.
2. **Current coil**—few turns of thick wire, connected in series with load

3. **Stator**—concentrates and confines magnetic field.
4. **Aluminum rotor disc.**
5. **Rotor brake magnets**
6. **Spindle with worm gear.**
7. **Display dials**

A single phase energy meter has four essential parts:

- (i) Operating system
- (ii) Moving system
- (iii) Braking system
- (iv) Registering system

1. Operating System

The operating system consists of two electromagnets. The cores of these electromagnets are made of silicon steel laminations. The coils of one of these electromagnets (series magnet) are connected in series with the load, and is called the current coil. The other electromagnet (shunt magnet) is wound with a coil that is connected across the supply, called the pressure coil. The pressure coil, thus, carries a current that is proportional to supply voltage.

Shading bands made of copper are provided on the central limb of the shunt magnet. Shading bands, as will be described later, are used to bring the flux i — Bearing produced by a shunt magnet exactly in quadrature Pivot with the applied voltage.

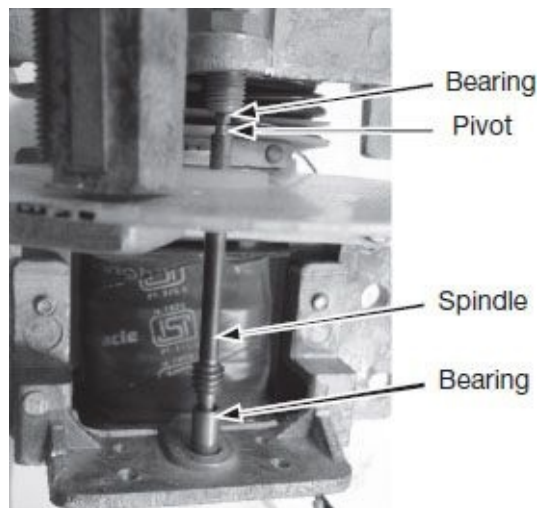

Figure 8.3 *Pivot and jewel bearing*

2. Moving System

The moving system consists of a light aluminum disc mounted on a spindle. The disc is placed in the space between the series and shunt magnets. The disc is so positioned that it intersects the flux produced by both the magnets. The deflecting torque on the disc is produced by interaction between these fluxes and the eddy current they induce in the disc. In energy meters, there is no control spring as such, so that there is continuous rotation of the disc.

The spindle is supported by a steel pivot supported by jewel bearings at the two ends, as shown in [Figure 8.3](#). A unique design for suspension of the rotating disc is used in 'floating-shaft' energy meters. In such a construction, the rotating shaft has one small piece of permanent magnet at each end. The upper magnet is attracted by a magnet placed in the upper bearing, whereas the lower magnet is attracted by another magnet placed in the lower bearing. The moving system thus floats without touching either of the bearing surfaces. In this way, friction while movement of the disc is drastically reduced.

3. Braking System

The braking system consists of a braking device which is usually a permanent magnet positioned near the edge of the aluminum disc. The arrangement is shown in [Figure 8.4](#).

The emf induced in the aluminum disc due to relative motion between the rotating disc and the fixed permanent magnet (brake magnet) induces eddy current in the disc. This eddy current, while interacting with the brake magnet flux, produces a retarding or braking torque. This braking torque is proportional to speed of the rotating disc. When the braking torque becomes equal to the operating torque, the disc rotates at a steady speed.

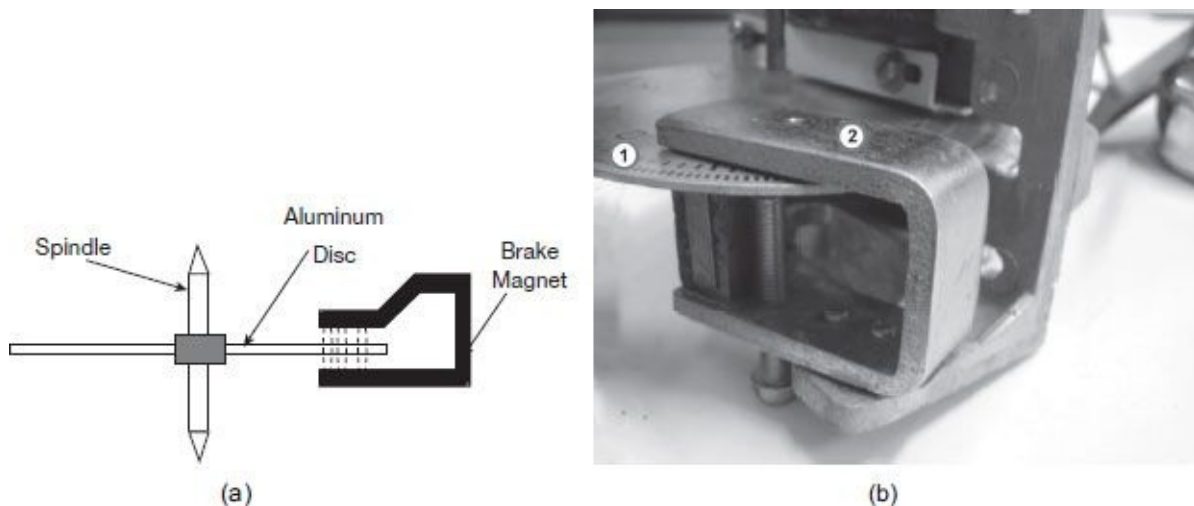

Figure 8.4 Brake magnet to provide eddy current braking in induction-type single-phase energy meter:
(a) Schematic diagram (b) Actual picture (1) Aluminum rotating disc (2) Brake magnet

The position of the permanent magnet with respect to the rotating disc is adjustable. Therefore, braking torque can be adjusted by shifting the permanent magnet to different radial positions with respect to the disc.

It is pertinent to mention here that the series magnet also acts as a braking magnet, since it opposes the main torque producing flux generated by the shunt magnet.

4. Registering System

The function of a registering or counting system is to continuously record a numerical value that is proportional to the number of revolutions made by the rotating system. By suitable combination of a train of reduction gears, rotation of the main aluminum disc can be transmitted to different pointers to register meter readings on different dials. Finally, the kWh reading can be obtained by multiplying the number of revolutions as pointed out by

the dials with the meter constant. The photograph of such a dial-type registering system is shown in [Figure 8.5](#).



Figure 8.5 Photograph of dial-type single phase energy meter

8.2.3 Operation of Induction-Type Energy Meter

As per construction, the pressure coil winding is made highly inductive by providing a large number of turns. The air gaps in a shunt magnet circuit are also made small to reduce the reluctance of shunt flux paths. Thus, as supply voltage is applied across the pressure coil, the current I_p through the pressure coil is proportional to the supply voltage and lags behind it by an angle that is only a few degrees less than 90° . Ideally, this angle of lag should have been 90° but for the small unavoidable resistance present in the winding itself and the associated iron losses in the magnetic circuit.

[Figure 8.6](#) shows the path of different fluxes while the meter is under operation. The corresponding phasor diagram is shown in [Figure 8.7](#).

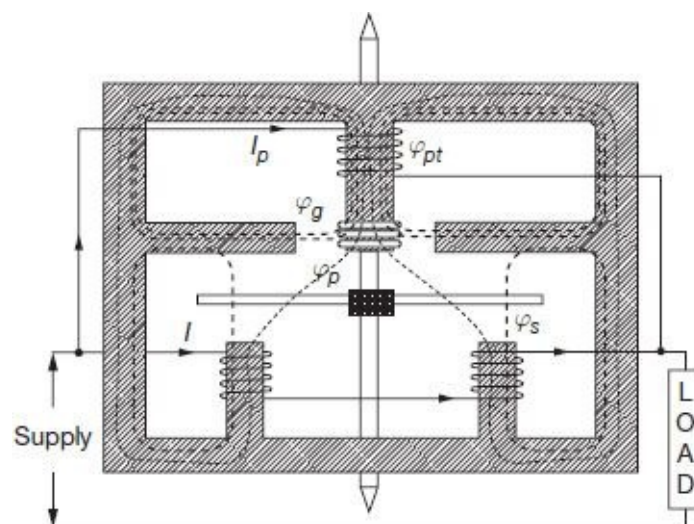

Figure 8.6 Flux paths in induction-type single-phase energy meter

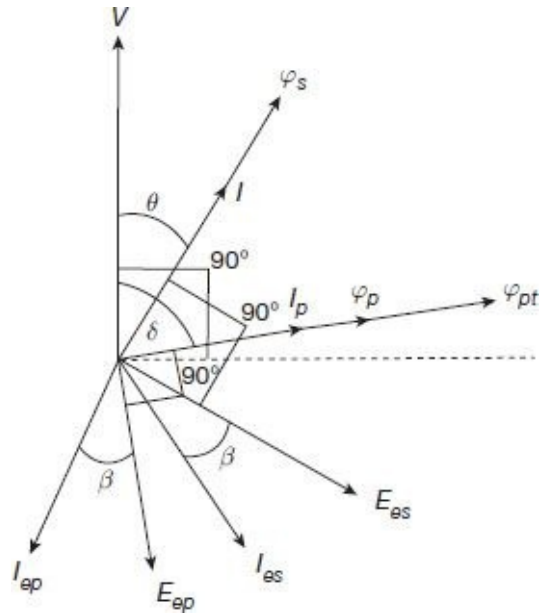

Figure 8.7 Phasor diagram of single-phase induction-type energy meter

Let,

V = supply voltage

I = load current

θ = phase angle of load

β = phase angle of aluminum disc

α = phase angle between shunt magnet and series magnet fluxes

δ = phase angle between supply voltage and pressure coil flux

The current I_p produces a flux ϕ_{pt} that is in same phase as I_p . This flux is made to divide itself in two parts, ϕ_g and ϕ_p . The major portion of total pressure coil flux, i.e., ϕ_g passes through the side gaps as shown in [Figure 8.6](#), as reluctance of these paths are low due very small air gaps. Remaining portion of the flux, i.e., ϕ_p passes through the disc and is responsible for production of the driving torque. Due to larger reluctance of the path, this flux ϕ_p is relatively weaker.

The flux ϕ_p is proportional to the current I_p and is in the same phase, as shown in the phasor diagram of [Figure 8.7](#). The flux ϕ_p is thus proportional to the supply voltage V and lags it by an angle δ which is only a few degrees less than 90° . The flux ϕ_p being alternating in nature, induces an eddy emf E_{ep} in the disc, which in turn produces eddy current I . Depending on the impedance angle β of the aluminum disc, eddy current I will lag behind the eddy emf E_{ep} by an angle β .

The load current I flows through the series magnet current coil and produces a flux ϕ_s . This flux is proportional to the load current I and is in phase with it. This flux, in the same way, induces an eddy emf E_{es} in the disc, which in turn produces eddy current I_{es} . The eddy current I_{es} lags behind the eddy emf E_{es} by the same angle β .

Now, the eddy current I_{es} interacts with flux ϕ_p to produce a torque and the eddy current I_{ep} interacts with flux ϕ_s to produce another torque. These two torques are in opposite

direction as shown in Figure 8.1, and the resultant torque is the difference of these two.

Following (8.1), the resultant deflecting torque on the disc due to combined action of two fluxes ϕ_p and ϕ_s is given as

$$T_d \propto \frac{\phi_p \phi_s \omega}{Z} \cdot \sin \alpha \cos \beta \tag{8.2}$$

where, Z is the impedance of the aluminum disc and ω is the angular frequency of supply voltage.

The driving torque can be re-written following the phasor diagram in Figure 8.7 as

$$T_d = K_1 \frac{\phi_p \phi_s \omega}{Z} \cdot \sin(\delta - \theta) \cos \beta, \text{ where } K_1 \text{ is a constant}$$

Since we have, $j_p \propto V$ and $\phi_s \propto I$,

$$\therefore \text{ driving torque } T_d = K_2 VI \frac{\omega}{Z} \cdot \sin(\delta - \theta) \cos \beta \tag{8.3}$$

$$\text{If } \omega, Z \text{ and } \beta \text{ are constants, then } T_d = K_3 VI \sin(\delta - \theta) \tag{8.4}$$

If N is the speed of rotation of the disc, then braking torque $T_b = K_4 N$

At steady running condition of the disc, the driving torque must equal the braking torque,

$$\therefore K_4 N = K_3 VI \sin(\delta - \theta)$$

$$\text{or, } N = KVI \sin(\delta - \theta) \tag{8.5}$$

If we can make $\delta = 90^\circ$

$$\begin{aligned} \text{Then speed of disc is } N &= KVI \sin(90^\circ - \theta) = KVI \cos \theta \\ \text{Thus speed } N &= K \times \text{Power} \end{aligned} \tag{8.6}$$

Thus, in order that the speed of rotation can be made to be proportionate to the power consumed, the angle difference δ between the supply voltage V and the pressure coil flux ϕ_p must be made 90°

Total number of revolutions within a time interval dt is

$$\begin{aligned} &= \int N dt = \int KVI \sin(\delta - \theta) dt \\ &= K \int VI \cos \theta dt \end{aligned} \tag{8.7}$$

$$\begin{aligned} \text{If, } \delta &= 90^\circ, \text{ total number of revolutions} \\ &= K \int (\text{power}) \times dt \\ &= K \times \text{Energy} \end{aligned}$$

Thus, total number of revolutions is proportional to the energy consumed.

8.3.1 Phase-angle Error

It is clear from (8.7) that the meter will indicate true energy only if the phase angle between the pressure coil flux ϕ_p and the supply voltage V is 90° . This requires that the pressure coil winding should be designed as highly inductive and its resistance and iron losses should be made minimum. But, even then the phase angle is not exactly 90° , rather a few degrees less than 90° . Suitable adjustments can be implemented such that the shunt magnet flux linking with the disc can be made to lag the supply voltage by an angle exactly equal to 90° .

1. Shading Coil with Adjustable Resistance

Figure 8.8 shows the arrangement where an additional coil (shading coil) with adjustable resistance is placed on the central limb of the shunt magnet close to the disc. Main flux created by the shunt magnet induces an emf in this shading coil. This emf creates its own flux. These two fluxes result in a modified flux to pass through the air gap to link the disc and thus produce the driving torque. With proper adjustment of the shading coil resistance, the resultant flux can be made to lag the supply voltage exactly by an angle of 90° .

Operation of the shading coil can be explained with the help of the phasor diagram shown in Figure 8.9. The pressure coil, when excited from the supply voltage V , carries a current I_p and produces an mmf AT_{pt} which in turn produces the total flux ϕ_{pt} . The flux ϕ_{pt} lags the supply voltage V by an angle ϕ which is slightly less than 90° . The current I_p produces a flux ϕ_{pt} that is in same phase as I_p . The flux ϕ_{pt} gets divided in two parts, ϕ and ϕ_p . The portion of flux ϕ passes through the side gaps as shown in Figure 8.8, and remaining portion of the flux, i.e., ϕ_p passes through the disc and also the shading coil. Due to linkage with the time varying flux, an emf E_{sc} is induced in the shading coil that lags behind its originating flux ϕ_p by 90° (i.e. E_{sc} is 180°) lagging behind the supply voltage V . This emf circulates and eddy current I_{sc} through the shading coil itself. I_{sc} lags behind the emf E_{sc} by an angle λ that depends on the impedance of the shading coil. The shading coil current I_{sc} produces an mmf AT_{sc} which is in phase with I_{sc} . The flux ϕ_p passing through to the disc will thus be due to the resultant mmf AT_p which is summation of the original mmf AT_{pt} and the mmf AT_{sc} due to the shading coil. This flux ϕ_p will be in phase with the mmf AT_p . As seen in the phasor diagram of Figure 8.9, the flux ϕ_p can be made to lag the supply voltage V by exactly 90° if the mmf AT_p or in other words, the shading coil phase angle λ can be adjusted properly. The shading coil phase angle can easily be adjusted by varying the external resistance connected to the shading coil.

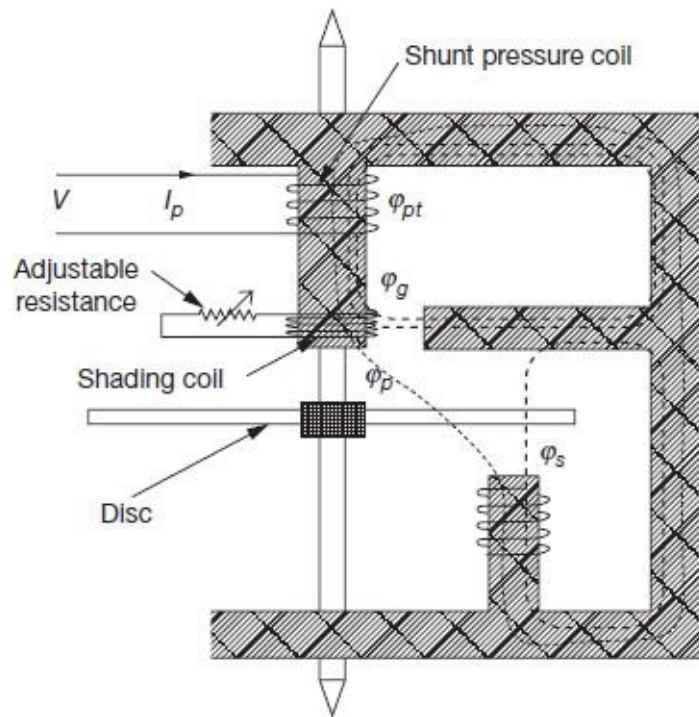

Figure 8.8 Shading coil for lag adjustment V

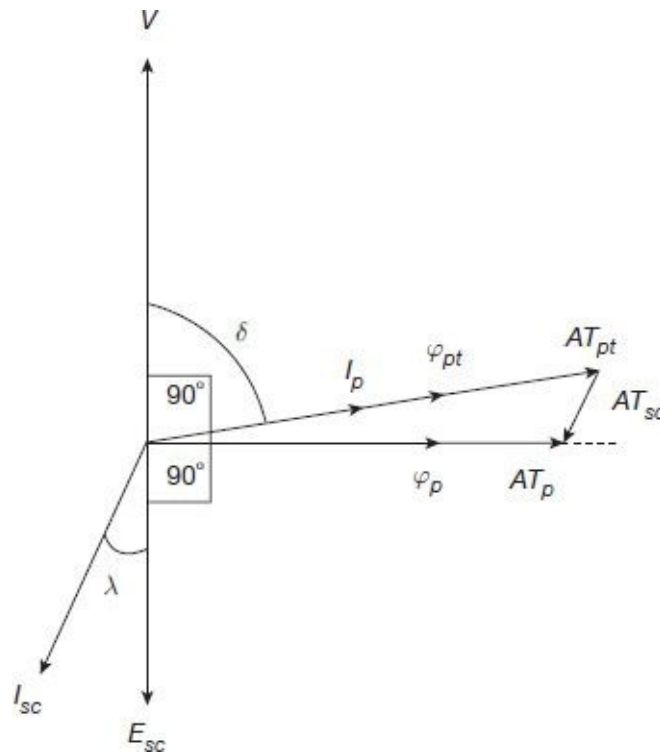

Figure 8.9 Phasor diagram showing operation of shading coil for lag adjustment

2. Copper Shading Bands

A similar result of lag adjustment can be obtained by the use of copper shading bands placed on the central limb of the shunt magnet. Such an arrangement is shown in [Figure 8.10](#). Following the same arguments, the resultant flux ϕ_p crossing over to the disc can be made to lag the supply voltage V by exactly 90° by proper adjustment of the mmf produced by the copper shading bands. Adjustments in this case can be done by moving the shading bands along the axis of the limb. As the bands are moved upwards along the limb, they embrace more flux. This results in increased values of induced emf, increased values of induced eddy current and hence increased values of the mmf produced by the

bands. Similarly, as the bands are moved downwards, mmf produced by the bands is reduced. This changes the phase angle difference between ϕ_p and ϕ_{pt} , as can be observed from the phasor diagram of [Figure 8.9](#). Thus, careful adjustments of the copper shading bands position can make the phase difference between the supply voltage V and resultant shunt magnet flux ϕ_p to be exactly 90° .

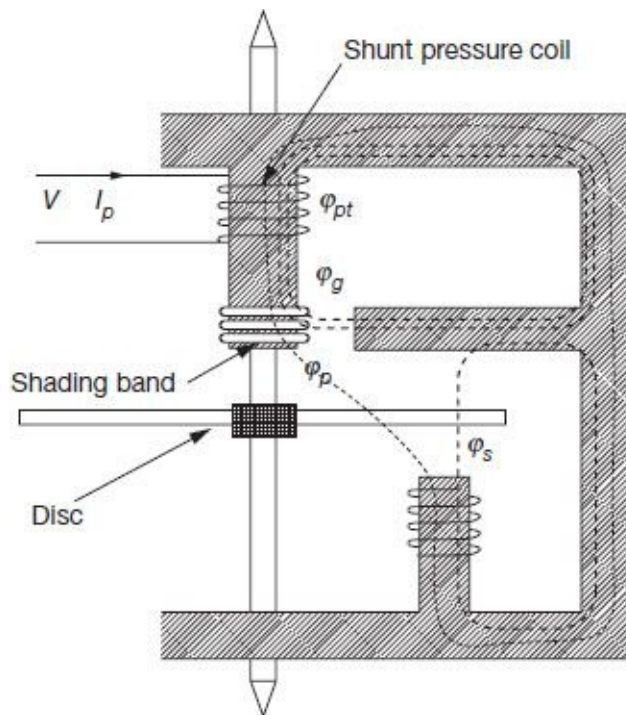

Figure 8.10 Copper shading bands for lag adjustment

8.3.2 Error due to Friction at Light Loads

Friction in bearings can pose serious errors in measurement of energy in the form of that it will impede proper movement of the rotating disc. This problem is particularly objectionable at low loads, when the driving torque itself is very low; therefore, unwanted friction torque can even stop the disc from rotating. To avoid this, it is necessary to provide an additional torque that is essentially independent of the load, to be applied in the direction of the driving torque, i.e., opposite to the frictional torque to compensate for the frictional retarding torque. This is achieved by means of a small vane or shading loop placed in the air gap between the central limb of the shunt magnet and the aluminum disc, and slightly off-centre from the central limb, as shown in [Figure 8.11](#). Interactions between fluxes which are linked and not linked by the shading or compensating vane and the currents they induce in the disc result in a small driving torque that can compensate for the frictional retarding torque. The value of this small additional torque can be adjusted by lateral movement of the vane in and out of its position in the air gap.

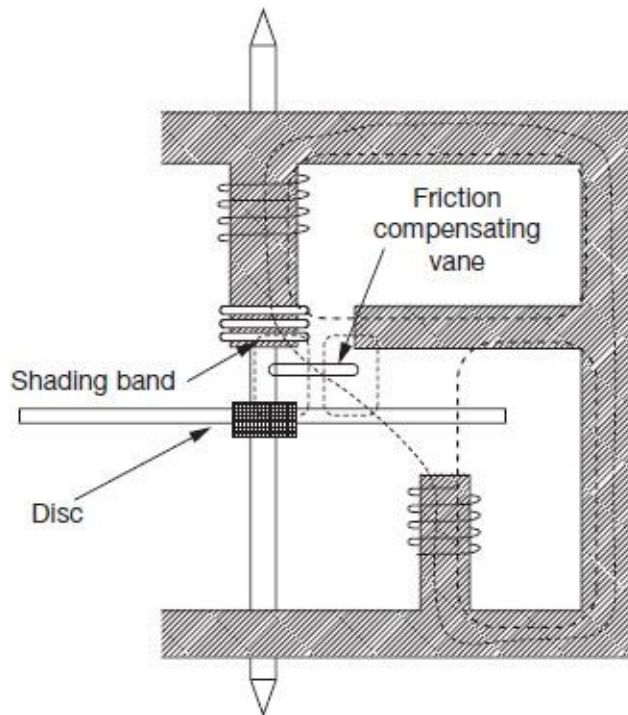

Figure 8.11 Shading vane for friction compensation

8.3.3 Creeping Error

In some meters, a slow but continuous rotation of the disc can be observed even when there is no current flowing through the current coil, and only pressure coil is energised. This is called **creeping**. The primary reason for creeping is due to over-compensation for friction. Though the main driving torque is absent at no-load, the additional torque provided by the friction compensating vane will make the disc continue to rotate. Other causes of creeping may be excessive voltage across the potential coil resulting in production of excessive torque by the friction compensating device, or vibrations, and stray magnetic fields.

Creeping can be avoided by drilling two holes on the aluminum disc placed on diametrically opposite locations. Drilling such holes will distort the eddy current paths along the disc and the disc will tend to stop with the holes coming underneath the shunt magnet poles. The disc can thus creep only till a maximum of half the rotation till one of the holes comes below the shunt magnet pole. This effect is however, too insignificant to hamper disc movement during normal running operations under load.

Creeping can also be avoided by attaching a tiny piece of iron to the edge of the disc. The brake magnet in such a case can lock the iron piece to itself and prevent creeping of the disc. Once again, this action is too insignificant to hamper disc movement during normal running operations under load. The arrangement is schematically shown in [Figure 8.12](#).

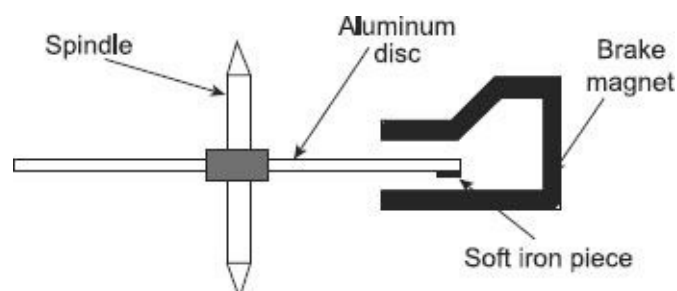

Figure 8.12 Soft iron piece at the end of the disc to prevent creeping

8.3.4 Error due to Change in Temperature

Errors introduced by variation of temperature in induction-type energy meters are usually small since the various effects tend to neutralise each other. An increase in temperature increases the pressure coil resistance, thereby reducing pressure coil current and reducing pressure coil flux. This will tend to reduce the driving torque. But the flux of the brake magnet also reduces due to increase in temperature, thereby reducing the braking torque. Again, an increase in temperature increases the resistance to eddy current path in the disc, which reduces both driving torque and braking torque. The various effects thus tend to neutralise each other.

The effects of increasing temperature, however, in general cause the meter to rotate faster and hence record higher values. Temperature effects thus need to be compensated for by using temperature shunts in the brake magnet.

8.3.5 Error due to Overload

At a constant voltage, the deflecting torque becomes simply proportional to the series magnet flux and hence proportional to the load current. This is due to the fact that from Eq. (8.2), at constant voltage as the shunt magnet flux ϕ_p is constant, the driving torque $T_d \propto \phi_s \propto I$.

On the other hand, as the disc rotates continuously in the field of the series magnet, an emf is induced dynamically in the disc due to its linkage with the series magnet flux ϕ_s . This emf induces eddy currents in the disc that interact with the series magnet flux to create a retarding or braking torque that opposes motion of the disc. This self braking torque is proportional to the square of the series magnet flux or is proportional to the square of the load current; i.e., $T_b \propto \phi_s^2 \propto I^2$.

At higher loads, thus the braking torque overpowers the deflecting torque and the meter tends to rotate at slower speed, and consequently reads lower than actual.

To avoid such errors, and to minimise the self-braking action, the full load speed of the disc is set at lower values. The current coil flux ϕ_s is made smaller as compared to the pressure coil flux ϕ_p . Thus, the dynamically induced emf that causes the braking torque is restricted as compared to the driving torque. Magnetic shunts are also sometimes used with series magnets to compensate for overload errors at high current values.

8.3.6 Error due to Voltage Variations

Voltage variations can cause errors in induction-type energy meters mainly due to two reasons:

1. At too high voltages, the relationship between the supply voltage V and the shunt magnet flux ϕ_p no longer remain linear due to saturation of iron parts, and
2. For sudden fluctuations in supply voltage, the shunt magnet flux ϕ_p produces a dynamically induced emf in the disc which in turn results in a self-braking torque and the disc rotation is hampered.

Compensation for voltage variation is provided by using a suitable magnetic shunt that diverts a major portion of the flux through the disc when the voltage rises, thereby increasing the driving torque to overcome the self-braking torque. Such compensation can be achieved by increasing the reluctance of the side limbs of the shunt magnet. This is done by providing holes in the side limbs as shown in [Figure 8.13](#).

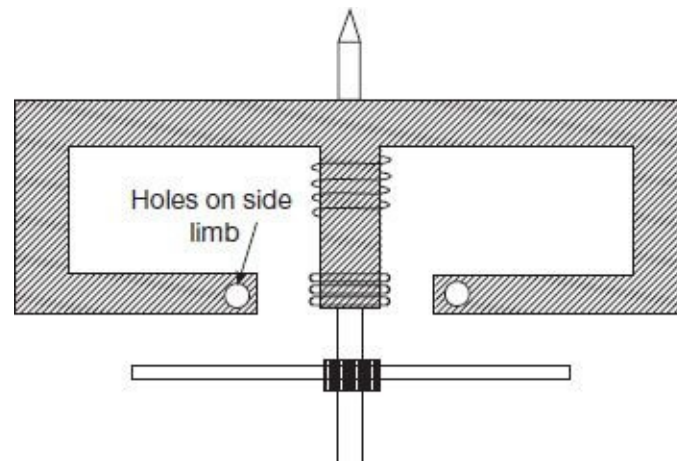

Figure 8.13 Holes provided on side limbs to compensate for errors due to sudden voltage variations

8.4

TESTING OF ENERGY METERS

Energy meters are tested at the following conditions:

1. At 5% of rated current at unity power factor
2. At 100% or 125% of rated current with unity power factor
3. At one intermediate load with unity power factor
4. At rated current and 0.5 lagging power factor
5. *Creep test* With pressure coil supplied with 110% of rated voltage and current coil open circuited, the meter disc should not rotate by more than one revolution, i.e., it should not creep
6. *Starting test* At 0.5% of rated current and full rated voltage, the meter disc should start rotating

8.4.1 Phantom Loading

When the current rating of the meter under test is high, a test with actual loading arrangements would involve considerable wastage of energy and also it is difficult to arrange for such large loads under laboratory test conditions. In such cases, to avoid this, 'phantom' or 'fictitious' loading arrangements are done for testing of energy meters.

Phantom loading consists of supplying the shunt magnet pressure coil circuit from a rated voltage source. The series magnet current coil is supplied from a separate low voltage supply source. It is possible to circulate rated current through the current coil circuit with the low voltage source since impedance of this circuit is very low. The energy indicated by the meter under phantom loading condition is the same as the energy

indication as would have been with a real load. With this arrangement, the total energy consumed for the test is comparatively smaller. The total energy required for the test is that due to the small pressure coil current at rated voltage and small current coil voltage at rated current.

Example 8.1

The meter constant of a 220 V, 5 A energy meter is 2000 revolutions per kWh. The meter is tested at half load at rated voltage and unity power factor. The meter is found to make 34 revolutions in 116 s. Determine the meter error at half load.

Solution Actual energy consumed at half load during 116 s:

$$= VI \cos \phi \times t \times 10^{-3} = 220 \times 2.5 \times \frac{116}{60 \times 60} \times 10^{-3} = 17.72 \times 10^{-3} \text{ kWh}$$

Energy as recorded by the meter

$$= \frac{\text{Number of revolutions made}}{\text{Meter constant (rev/kWh)}} = \frac{34}{2000} = 17 \times 10^{-3} \text{ kWh}$$

$$\therefore \text{Error} = \frac{17 - 17.72}{17.72} \times 100\% = -4.06\% \text{ (meter runs slower)}$$

Example 8.2

A 230 V, 5 A energy meter on full load unity power factor test makes 60 revolutions in 360 seconds. If the designed speed of the disc is 520 revolutions per kWh, find the percentage error.

Solution Actual energy consumed at full load during 360 s:

$$= VI \cos \phi \times t \times 10^{-3} = 230 \times 5 \times \frac{360}{60 \times 60} \times 10^{-3} = 115 \times 10^{-3} \text{ kWh}$$

Energy as recorded by the meter

$$= \frac{\text{Number of revolutions made}}{\text{Meter constant (rev/kWh)}} = \frac{60}{520} = 115.385 \times 10^{-3} \text{ kWh}$$

$$\therefore \text{Error} = \frac{115.385 - 115}{115} \times 100\% = 0.34\% \text{ (meter runs faster)}$$

Example 8.3

An energy meter is designed to have 80 revolutions of the disc per unit of energy consumed. Calculate the number of revolutions made by the disc when measuring the energy consumed by a load carrying 30 A at 230 V and 0.6 power factor. Find the percentage error if the meter actually makes 330 revolutions.

Solution Actual energy consumed by the load in one hour:

$$= VI \cos \phi \times t \times 10^{-3} = 230 \times 30 \times 0.6 \times 1 \times 10^{-3} = 4.14 \text{ kWh}$$

The meter makes 80 revolutions per unit of energy consumed, i.e., per kWh.

Thus number of revolutions made by the meter to record 4.14 kWh is

$$= 4.14 \times 80 = 331.2$$

In case the meter makes 330 revolutions, then error is given as

$$\text{Error} = \frac{330 - 331.2}{331.2} \times 100\% = -0.36\% \text{ (meter runs slower)}$$

Example 8.4

A 230 V, single-phase watt hour meter records a constant load of 10 A for 4 hours at unity power factor. If the meter disc makes 2760 revolutions during this period, what is the meter constant in terms of revolutions per unit? Calculate the load power factor if the number of revolutions made by the meter is 1104 when recording 5 A at 230 V for 6 hours.

Solution Actual energy consumed by the load in 4 hours:

$$= VI \cos \phi \times t \times 10^{-3} = 230 \times 10 \times 1 \times 4 \times 10^{-3} = 9.2 \text{ kWh}$$

$$\therefore \text{Meter constant} = \frac{\text{Number of revolutions made}}{\text{kWh consumed}} = \frac{2760}{9.2} = 300 \text{ rev/kWh}$$

With this value of meter constant, with 1104 revolutions, the meter records an energy = $1104/300$ 3.68 kWh

Thus, energy consumed

$$= VI \cos \phi \times t \times 10^{-3} = 230 \times 5 \times \cos \phi \times 6 \times 10^{-3} = 3.68 \text{ kWh}$$

Hence, power factor of load is $\cos \phi = 0.533$

Example 8.5

A 220 V, 10 A dc energy meter is tested for its name plate ratings. Resistance of the pressure coil circuit is 8000 Ω and that of current coil itself is 0.12 Ω . Calculate the energy consumed when testing for a period of 1 hour with
(a) Direct loading arrangement
(b) Phantom loading with the current coil circuit excited by a separate 9 V battery

Solution Test arrangements with direct and phantom loading arrangements are schematically shown in the figure.

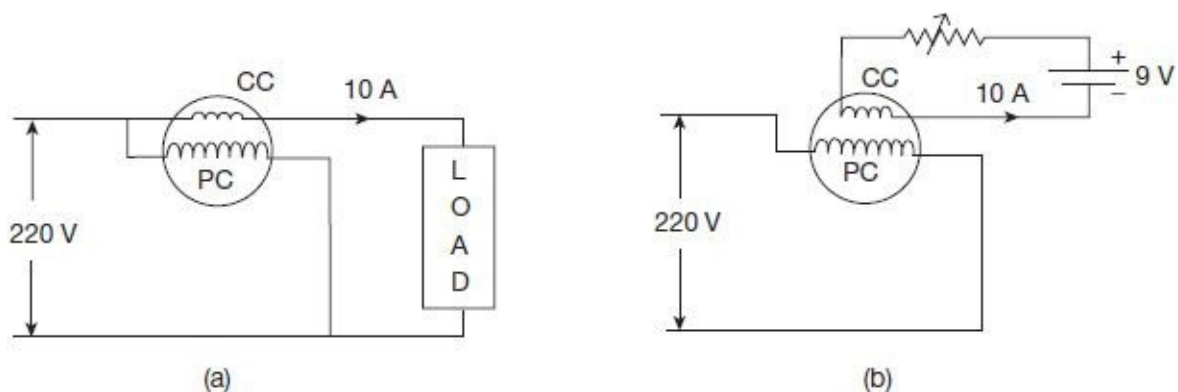

(a) With direct loading

$$\text{Power consumed in the pressure coil circuit} = \frac{(220)^2}{8000} = 6.05 \text{ W}$$

$$\text{Power consumed in the current coil (series) circuit} = 220 \times 10 = 2200 \text{ W}$$

$$\therefore \text{total power consumed with direct measurement} = 2206.05 \text{ W}$$

$$\therefore \text{total energy consumed during 1 hour with direct measurement}$$

$$= 2206.05 \times 1 \times 10^{-3} = 2.20605 \text{ kWh}$$

(b) *With phantom loading*

$$\text{Power consumed in the pressure coil circuit} = \frac{(220)^2}{8000} = 6.05 \text{ W}$$

$$\text{Power consumed in the current coil (series) circuit} = 9 \times 10 = 90 \text{ W}$$

$$\therefore \text{total power consumed with direct measurement} = 96.05 \text{ W}$$

$$\therefore \text{total energy consumed during 1 hour with direct measurement}$$

$$= 96.05 \times 1 \times 10^{-3} = 0.09605 \text{ kWh}$$

Thus, energy consumed is considerably less in phantom loading as compared to direct loading for energy meter testing.

EXERCISE

EXERCISE

Objective-type Questions

- Energy meters do not have a control spring to
 - avoid unnecessary friction losses
 - enable continuous rotation of the disc
 - avoid damping during movement
 - all of the above
- In induction-type energy meters, the speed of rotation of the disc is proportional to the
 - energy consumption
 - power consumption
 - derivative of power consumption
 - none of the above
- The advantages of induction-type energy meters are
 - low torque/weight ratio
 - low friction
 - high and sustained accuracy
 - all of the above
- Induction-type energy meters have aluminum disc as the rotating part so that
 - flux can pass through the rotating part
 - eddy current can be induced in the rotating part

- (c) creeping error can be avoided
 - (d) all of the above
5. In induction-type energy meters
- (a) pressure coil is the moving part
 - (b) current coil is the moving part
 - (c) both current and pressure coils are moving
 - (d) both current and pressure coils are stationary
6. In induction-type energy meters, high driving torque can be obtained by
- (a) making the disc purely resistive
 - (b) making the phase difference between the two operating fluxes as large as possible
 - (c) making the disc impedance as low as possible
 - (d) all of the above
7. Braking torque provided by the permanent magnet in an induction-type energy meter is proportional to
- (a) speed of the rotating disc
 - (b) square of the flux of the permanent magnet
 - (c) distance of the permanent magnet with respect to centre of the disc
 - (d) all of the above
8. Braking torque provided by the permanent magnet in an induction-type energy meter can be changed by
- (a) providing a metal shunt and shifting its position
 - (b) moving the position of the permanent magnet with respect to the disc
 - (c) both (a) and (b)
 - (d) none of the above
9. In single-phase induction-type energy meters, maximum torque is produced when the shunt magnet flux
- (a) leads the supply voltage by 90°
 - (b) lags the supply voltage by 90°
 - (c) lags the supply voltage by 45°
 - (d) is in phase with the supply voltage
10. In single-phase induction-type energy meters, lag adjustments are done by
- (a) permanent magnet placed on the edge of the disc
 - (b) holes provided on the side limbs of the pressure coil
 - (c) copper shading bands placed on the central limb of the pressure coil
 - (d) metal shunts placed on the series magnets
11. In single-phase induction-type energy meters, lag adjustments can be done by
- (a) shifting the copper shading band along the axis of the central limb
 - (b) varying the external resistance connected to the shading coil placed on the central limb
 - (c) either of (a) or (b) as the case may be
 - (d) none of the above
12. In single-phase induction-type energy meters, friction compensation can be done by
- (a) placing shading bands in the gap between central limb and the disc
 - (b) drilling diametrically opposite holes on the disc
 - (c) providing holes on the side limbs
 - (d) all of the above

13. Creeping in a single-phase energy meter may be due to
 - (a) vibration
 - (b) overcompensation of friction
 - (c) over voltages
 - (d) all of the above
14. Creeping in a single-phase energy meter can be avoided by
 - (a) using good quality bearings
 - (b) increasing strength of the brake magnet
 - (c) placing small soft iron piece on edge of the rotating disc
 - (d) all of the above
15. Increase in operating temperature in an induction-type energy meter will
 - (a) reduce pressure coil flux
 - (b) reduce braking torque
 - (c) reduce driving torque
 - (d) all of the above
16. Overload errors in induction-type energy meters can be reduced by
 - (a) designing the meter to run at lower rated speeds
 - (b) designing the current coil flux to have lower rated values as compared to pressure coil flux
 - (c) providing magnetic shunts along with series magnets that saturate at higher loads
 - (d) all of the above
17. Over voltages may hamper rotation of the disc in induction-type energy meters since
 - (a) the pressure coil flux no longer remains in quadrature with the current coil flux
 - (b) dynamically induced emf in the disc from the pressure coil flux produces a self-braking torque
 - (c) effect of the brake magnet is enhanced
 - (d) all of the above
18. If an induction-type energy meter runs fast, it can be slowed down by
 - (a) moving up the copper shading bands placed on the central limb
 - (b) adjusting the magnetic shunt placed on the series magnets
 - (c) moving the permanent brake magnet away from centre of the disc
 - (d) bringing the permanent brake magnet closer to centre of the disc
19. Phantom loading for testing of energy meters is used
 - (a) for meters having low current ratings
 - (b) to isolate current and potential circuits
 - (c) to test meters having a large current rating for which loads may not be available in the laboratory
 - (d) all of the above
20. In single-phase induction-type energy meters, direction of rotation of the disc can be reversed by
 - (a) reversing supply terminals
 - (b) reversing load terminals
 - (c) opening the meter and reversing either the potential coil terminals or the current coil terminals
 - (d) opening the meter and reversing both the potential coil terminals and the current coil terminals

Answers

1. (b)	2. (b)	3. (a)	4. (b)	5. (d)	6. (a)	7. (d)
8. (c)	9. (b)	10. (c)	11. (c)	12. (d)	13. (b)	14. (c)
15. (d)	16. (d)	17. (b)	18. (d)	19. (c)	20. (c)	

Short-answer Questions

1. Draw a schematic diagram showing construction details of an induction-type energy meter and label its different parts. Comment on the different materials used for the different internal components.
2. Why braking torque is necessary in induction type energy meters? Draw and explain how braking arrangement is done such instruments.
3. Why is it necessary to have lag adjustment devices in induction type energy meters? Draw and explain in brief, operation of such arrangements in a single-phase energy meter.
4. What is the effect of friction in induction-type energy meters? How is it overcome in practice?
5. What is creeping error in an energy meter? What are its possible causes? How can it be compensated in an induction type energy meter?
6. Explain the effects of over-load in induction type energy meters. How can this effect be avoided?
7. Why can sudden voltage variations cause errors in induction type energy meter readings? Discuss how these errors can be minimized.
8. List the tests normally carried out on single phase energy meters? Why phantom loading arrangement is done for testing high capacity energy meters?

Long-answer Questions

1. Derive an expression for the driving torque in a single phase induction type meter. Show that the driving torque is maximum when the phase angle between the two fluxes is 90° and the rotating disc is purely non-inductive.
2. Draw the schematic diagram of the internal operating parts of a single phase induction type energy meter. Comment of the materials used and operation of the different internal parts.
3. Draw and describe the relevant phasor diagram and derive how the number of revolutions in a single phase induction type energy meter is proportional to the energy consumed.
4. (a) Explain the sources of error in a single phase induction type energy meter.
(b) A 220 V, 5 A energy meter on full load unity power factor test makes 60 revolutions in 360 seconds. If the designed speed of the disc is 550 revolutions per kWh, find the percentage error.
5. (a) What is phase angle error in an induction type energy meter? Explain how this error is reduced in a single phase induction type energy meter.
(b) An energy meter is designed to have 60 revolutions of the disc per unit of energy consumed. Calculate the number of revolutions made by the disc when measuring the energy consumed by a load carrying 20 A at 230 V and 0.4 power factor. Find the percentage error if the meter actually makes 110 revolutions.
6. (a) What is the effect of friction in induction-type energy meters? How is it overcome? What is creeping error? How is it overcome?
(b) A 230 V single-phase watt-hour meter records a constant load of 5 A for 6 hours at unity power factor. If the meter disc makes 2760 revolutions during this period, what is the meter constant in terms of revolutions per unit? Calculate the load power factor if the number of revolutions made by the meter is 1712 when recording 4 A at 230 V for 5 hours.
7. (a) What are the tests normally carried out on single-phase energy meters? Why is phantom loading arrangement is done for testing high capacity energy meters?
(b) A 230 V, 5 A dc energy meter is tested for its name plate ratings. Resistance of the pressure coil circuit is 6000Ω and that of current coil itself is 0.15Ω . Calculate the energy consumed when testing for a period of 2 hours with

(i) Direct loading arrangement

- (ii) Phantom loading with the current coil circuit excited by a separate 6 V battery

9.1**INTRODUCTION**

The Cathode Ray Oscilloscope (CRO) is a very useful and versatile laboratory instrument used for display, measurement and analysis of waveform and other phenomena in electrical and electronic circuits. CROs are, in fact, very fast X - Y plotters, displaying an input signal versus another signal or versus time. The 'stylus' of this 'plotter' is a luminous spot which moves over the display area in response to an input voltage. The luminous spot is produced by a beam of electrons striking a fluorescent screen. The extremely low inertia effects associated with a beam of electrons enables such a beam to be used following the changes in instantaneous values of rapidly varying voltages.

The normal form of a CRO uses a horizontal input voltage which is an internally generated ramp voltage called 'time base'. The horizontal voltage moves the luminous spot periodically in a horizontal direction from left to right over the display area or screen. The vertical input to the CRO is the voltage under investigation. The vertical input voltage moves the luminous spot up and down in accordance with the instantaneous value of the voltage. The luminous spot thus traces the waveform of the input voltage with respect to time. When the input voltage repeats itself at a fast rate, the display on the screen appears stationary on the screen. The CRO thus provides a means of visualising time-varying voltages. As such, the CRO has become a universal tool in all kinds of electrical and electronic investigation.

9.2**BLOCK DIAGRAM OF A CATHODE RAY TUBE (CRT)**

The main part of the CRO is Cathode Ray Tube (CRT). It generates the electron beam, accelerates the beam to a high velocity, deflects the beam to create the image and contains a phosphor screen where the electron beam eventually becomes visible. The phosphor screen is coated with 'aquadag' to collect the secondary emitted electrons. For accomplishing these tasks, various electrical signals and voltages are required, which are provided by the power supply circuit of the oscilloscope. Low voltage supply is required for the heater of the electron gun for generation of electron beam and high voltage, of the order of few thousand volts, is required for cathode ray tube to accelerate the beam. Normal voltage supply, say a few hundred volts, is required for other control circuits of the oscilloscope.

Horizontal and vertical deflecting plates are fitted between the electron gun and screen to deflect the beam according to the input signal. The electron beam strikes the screen and creates a visible spot. This spot is deflected on the screen in the horizontal direction (X -

axis) with constant time dependent rate. This is accomplished by a time base circuit provided in the oscilloscope. The signal to be viewed is supplied to the vertical deflection plates through the vertical amplifier, which raises the potential of the input signal to a level that will provide usable deflection of the electron beam. Now electron beam deflects in two directions, horizontal on X -axis and vertical on Y -axis. A triggering circuit is provided for synchronising two types of deflections so that horizontal deflection starts at the same point of the input vertical signal each time it sweeps. A basic block diagram of a general-purpose oscilloscope is shown in Figure 9.1(a) and a schematic of internal parts of a CRT is shown in Figure 9.1(b).

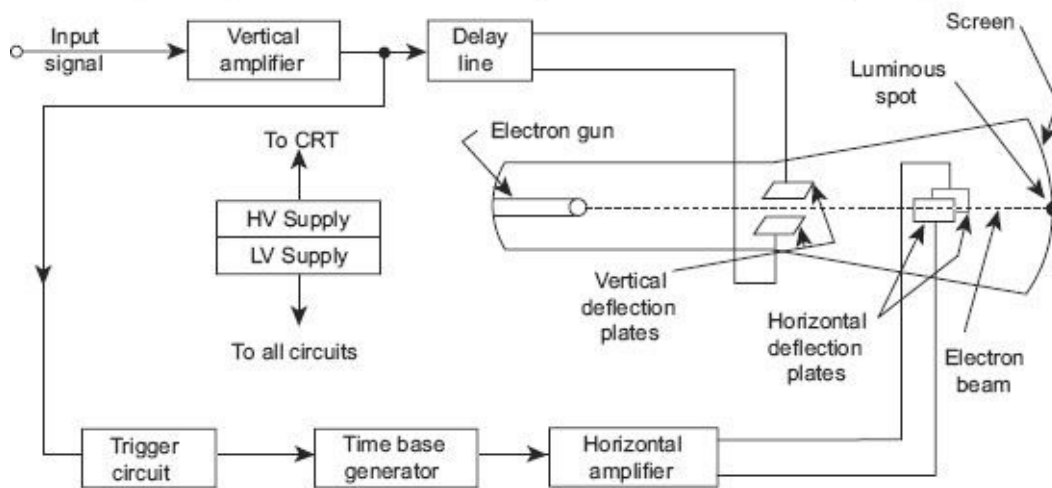

Figure 9.1 (a) Block diagram of a general-purpose CRO

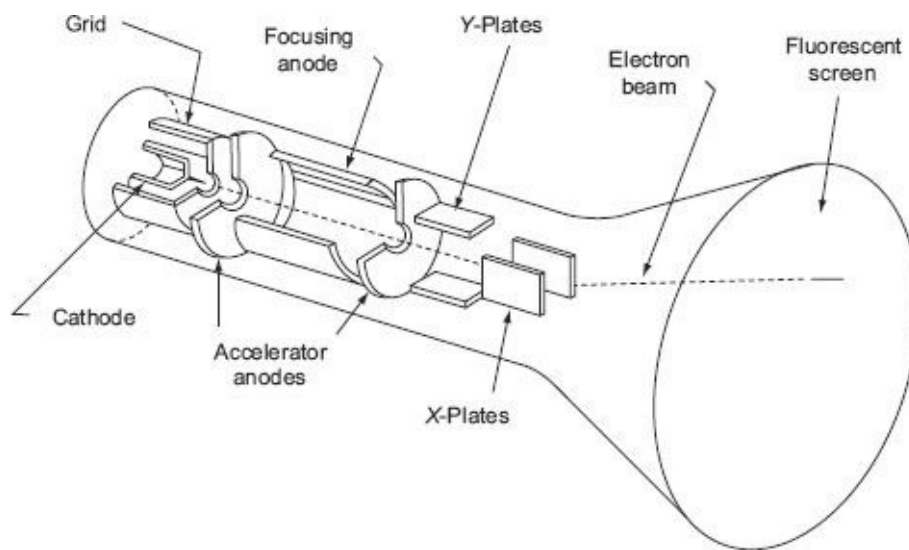

Figure 9.1 (b) Cathode Ray Tube(CRT)

9.3

ELECTROSTATIC DEFLECTION

Figure 9.2 shows a general arrangement for electrostatic deflection. There are two parallel plates with a potential applied between. These plates produce a uniform electrostatic field in the Y direction. Thus any electron entering the field will experience a force in the Y direction and will be accelerate in that direction. There is no force either in X direction or Z direction and hence there will be no acceleration of electrons in these directions.

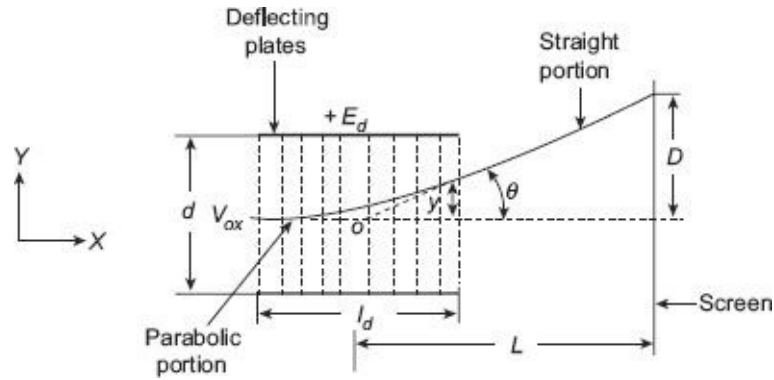

Figure 9.2 Electrostatic deflection

Let, E_a = voltage of pre-accelerating anode; (volt)

e = charge of an electron; (Coulomb)

m = mass of electron; (kg)

θ = deflection angle of the electron beam

v_{ox} = velocity of electron when entering the field of deflecting plates; (m/s)

E_d = potential difference between deflecting plates; (volt)

d = distance between deflecting plates; (m)

l_d = length of deflecting plates; (m)

L = distance between screen and the centre of the deflecting plates; (m)

y = displacement of the electron beam from the horizontal axis at time t

and D = deflection of the electron beam on the screen in Y direction; (m)

The loss of potential energy (PE) when the electron moves from cathode to accelerating anode;

$$PE = eE_a \quad (9.1)$$

The gain in kinetic energy (KE) by an electron

$$KE = \frac{1}{2} m v_{ox}^2 \quad (9.2)$$

Equating the two energies, we have $v_{ox} = \sqrt{\frac{2eE_a}{m}}$ (9.3)

This is the velocity of the electron in the X direction when it enters the deflecting plates. The velocity in the X direction remains same throughout the passage of electrons through the deflecting plates as there is no force acting in the direction.

The electric field intensity in the Y direction $\epsilon_y = \frac{E_d}{d}$ (9.4)

Force acting on an electron in Y direction = $F_y = e\epsilon_y = e \frac{E_d}{d}$ (9.5)

Suppose a_y is the acceleration of the electron in the Y direction, therefore,

$$F_y = m a_y \quad (9.6)$$

or, $a_y = \frac{e\epsilon_y}{m}$ (9.7)

As there is no initial velocity in the Y direction [Eq. (9.8)], the displacement y at any instant t in the Y direction is

$$y = \frac{1}{2}a_y t^2 = \frac{1}{2} \frac{e\mathcal{E}_y}{m} t^2 \quad (9.8)$$

As the velocity in the X direction is constant, the displacement in X direction is given by

$$x = v_{ox} t \quad (9.9)$$

$$\therefore t = \frac{x}{v_{ox}} \quad (9.10)$$

Substituting the above value of t in Eq. (9.8), we have

$$y = \frac{1}{2} \frac{e\mathcal{E}_y}{m v_{ox}^2} x^2 \quad (9.11)$$

This is the equation of a parabola.

$$\text{The slope at any point } (x, y) \text{ is } \frac{dy}{dx} = \frac{e\mathcal{E}_y}{m v_{ox}^2} x \quad (9.12)$$

Putting $x = l_d$ in Eq. (9.12), we get the value of $\tan \theta$.

$$\text{or } \tan \theta = \frac{e\mathcal{E}_y}{m v_{ox}^2} l_d = \frac{eE_d l_d}{m d v_{ox}^2} \quad (9.13)$$

After leaving the deflection plates, the electrons travel in a straight line. The straight line of travel of electron is tangent to the parabola at $x = l_d$ and this tangent intersects the X axis at point O' . The location of this point is given by

$$x = \frac{y}{\tan \theta} = \frac{e\mathcal{E}_y l_d^2 / 2}{\frac{e\mathcal{E}_y}{m v_{ox}^2} l_d} = \frac{l_d}{2} \quad (9.14)$$

The apparent origin is thus the centre of the deflecting plates, the deflection D on the screen is given by

$$D = L \tan \theta = \frac{L e E_d l_d}{m d v_{ox}^2} \quad (9.15)$$

Substituting the value $v_{ox}^2 = \frac{2eE_a}{m}$ in Eq. (9.15), we get,

$$\boxed{D = \frac{L e E_d l_d}{m d} \cdot \frac{m}{2eE_a} = \frac{L E_d l_d}{2d E_a}} \quad (9.16)$$

From Eq. (9.16) we conclude the following:

For a given accelerating voltage E_a , and for particular dimensions of CRT, the deflection of the electron beam is directly proportional to the deflecting voltage. This means that the CRT may be used as a linear indicating device.

The discussions above assume that E_d is a fixed dc voltage. The deflection voltage is usually a time varying quantity and the image on the screen thus follows the variation of the deflections voltage in a linear manner.

The deflection is independent of the (e/m) ratio. In a cathode ray tube, in addition to the electrons many types of negative ions such as oxygen, carbon, chlorine etc are present. With electrostatic deflection system, because deflection is independent of e/m , the ions

travel with the electrons and are not concentrated at one point. Hence cathode ray tube with electrostatic deflection system does not produce an ion burn.

The *deflection sensitivity* of a CRT is defined as the deflection of the screen per unit deflection voltage.

Therefore, deflection sensitivity
$$S = \frac{D}{E_d} = \frac{Ll_d}{2dE_a} \text{ m/V} \quad (9.17)$$

The *deflection factor* of a CRT is defined as the reciprocal of sensitivity

Therefore, deflection factor
$$G = \frac{1}{S} = \frac{2dE_a}{Ll_d} \text{ V/m} \quad (9.18)$$

It is clear from Eq. (9.17), that the sensitivity can be increased by decreasing the value of accelerating voltage E_a . but this has a disadvantage as the luminosity of the spot is decreased with decrease in E_a . On the other hand a high value of E_a , produced a highly accelerated beam and thus produces a bright spot. However, a high accelerating voltage (E_a) requires a high deflection potential (E_d) for a given deflection. Also, highly accelerated beam is more difficult to deflect and is sometimes called *hard beam*.

Example 9.1

An electrically deflected CRT has a final anode voltage of 2000 V and parallel deflecting plates 1.5 cm long and 5 mm apart. If the screen is 50 cm from the centre of deflecting plates, find (a) beam speed, (b) the deflection sensitivity of the tube, and (c) the deflection factor of the tube.

Solution Velocity of the beam

$$v_{ox} = \sqrt{\frac{2eE_a}{m}} = \sqrt{\frac{2 \times 1.6 \times 10^{-19} \times 2000}{9.1 \times 10^{-31}}} = 26.5 \times 10^6 \text{ m/s}$$

Deflection sensitivity,

$$S = \frac{Ll_d}{2dE_a} = \frac{0.5 \times 1.5 \times 10^{-2}}{2 \times 5 \times 10^{-3} \times 2000} = 0.375 \text{ mm/V}$$

Deflection factor, $G = \frac{1}{S} = \frac{1}{0.375} = 2.66 \text{ V/mm}$

Example 9.2

Calculate the maximum velocity of the beam of electrons in a CRT having a anode voltage of 800 V. Assume that the electrons to leave the anode with zero velocity. Charge of electron = $1.6 \times 10^{-19} \text{ C}$ and mass of electron = $9.1 \times 10^{-31} \text{ kg}$.

Solution Velocity of electron is

$$v_{ox} = \sqrt{\frac{2eE_a}{m}} = \sqrt{\frac{2 \times 1.6 \times 10^{-19} \times 800}{9.1 \times 10^{-31}}} = 16.8 \times 10^6 \text{ m/s}$$

Example 9.3

A CRT has an anode voltage of 2000 V and 2 cm long and 5 mm apart parallel deflecting plates. The screen is 30 cm from the centre of the plates. Find the input voltage required to deflect the beam through 3 cm. The input voltage is applied to the deflecting plates through amplifiers having an overall gain of 100.

Solution

$$\text{Deflection } D = \frac{LeE_d l_d}{md} \cdot \frac{m}{2eE_a} = \frac{LE_d l_d}{2dE_a}$$

$$\therefore \text{ voltage applied to the deflecting plates } E_d = \frac{2dE_a D}{Ll_d}$$

$$= \frac{2 \times 5 \times 10^{-3} \times 2000 \times 3 \times 10^{-2}}{0.3 \times 2 \times 10^{-2}} = 100 \text{ V}$$

$$\therefore \text{ input voltage required for a deflection of 3 cm} = \frac{E_d}{\text{gain}} = \frac{100}{100} = 1 \text{ V.}$$

9.4

TIME BASE GENERATOR

Generally, oscilloscopes are used to display a waveform that varies as a function of time. For the waveform to be accurately reproduced, the beam must have a constant horizontal velocity. Since the beam velocity is a function of the deflecting voltage, the deflecting voltage must increase linearly with time. A voltage with this characteristic is called a *ramp voltage*. If the voltage decreases rapidly to zero with the waveform repeatedly reproduced, as shown in [Figure 9.3](#), the pattern is generally called a sawtooth waveform.

During the sweep time, T_s , the beam moves from left to right across the CRT screen. The beam is deflected to the right by the increasing amplitude of the ramp voltage and the fact that the positive voltage attracts the negative electrons. During the retrace time or flyback time, T_r , the beam returns quickly to the left side of the screen. This action would cause a retrace line to be printed on the CRT screen. To overcome this problem the control grid is generally 'gated off', which blanks out the beam during retrace time and prevents an undesirable retrace pattern from appearing on the screen.

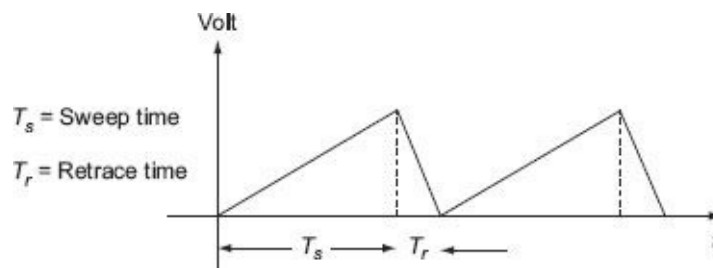

Figure 9.3 Typical sawtooth waveform applied to the horizontal deflection plates

In low-cost oscilloscopes the time base is said to be free running, although the time base oscillator may, in fact, be synchronised to the vertical amplifier signal. Unless the time base is so synchronous, the waveform marches across the screen and remains unstable.

Synchronisation means that the time base signal sweeps across the screen in a time that is equal to an integer number of vertical waveform periods. The vertical waveform will then appear locked on the CRT screen.

The vertical sector consists of a wideband preamplifier and power amplifier combination that drives the CRT vertical deflection plates. The vertical amplifier has a high gain, so large signals must be passed through an attenuator or, in low cost oscilloscopes, a vertical gain controller.

9.5

VERTICAL INPUT AND SWEEP GENERATOR SIGNAL SYNCHRONISATION

Several waveforms that are needed to be observed with the help of CRO will be changing at a rate much faster than the human eye can sense, perhaps many million times per second. To observe such rapid changes, the beam must retrace the same pattern repeatedly. If the pattern is retraced in such a manner that the pattern always occupies the same location on the screen, it will appear as stationary. The beam will retrace the same pattern at a rapid rate. If the vertical input signal and the sweep generator signal are synchronised, which means that the frequency of vertical input signal must be equal to or an exact multiple of the sweep generator signal frequency, as shown in [Figure 9.4](#). If the vertical input frequency is not exactly equal to or an exact multiple of the sawtooth frequency, the waveform will not be synchronised and the display moves across the screen. If the pattern moves towards the right, the frequency of the sawtooth waveform is too high. Movement of the pattern towards the left indicates that the frequency of the sawtooth is too low.

The vertical input signal and the sawtooth generator signal can be synchronized in two different ways:

1. Free running sweep
2. Triggered sweep

9.5.1 Free Running Sweep

In low-cost oscilloscopes, the time base is said to be free running. In these oscilloscopes, the sweep generator is continuously charging and discharging a capacitor. One ramp voltage is followed immediately by another; hence, the sawtooth pattern appears. A sweep generator working in this manner is said to be 'free running'. In order to present a stationary display on the CRT screen, the sweep generator signal must be forced to run in synchronisation with the vertical input signal. In basic or low-cost oscilloscopes this is accomplished by carefully adjusting the sweep frequency to a value very close to the exact frequency of the vertical input signal or a submultiple of this frequency. When both signals are at same frequency, an internal synchronising pulse will lock the sweep generator into the vertical input signal. This method of synchronisation has some serious limitations when an attempt is made to observe low amplitude signals, because it is very difficult to observe that a very low amplitude signal is stationary or movable in the CRT screen. However, the most serious limitation is probably the inability of the instrument to

maintain synchronisation when the amplitude or frequency of the vertical signal is not constant, such as variable frequency audio signal or voice.

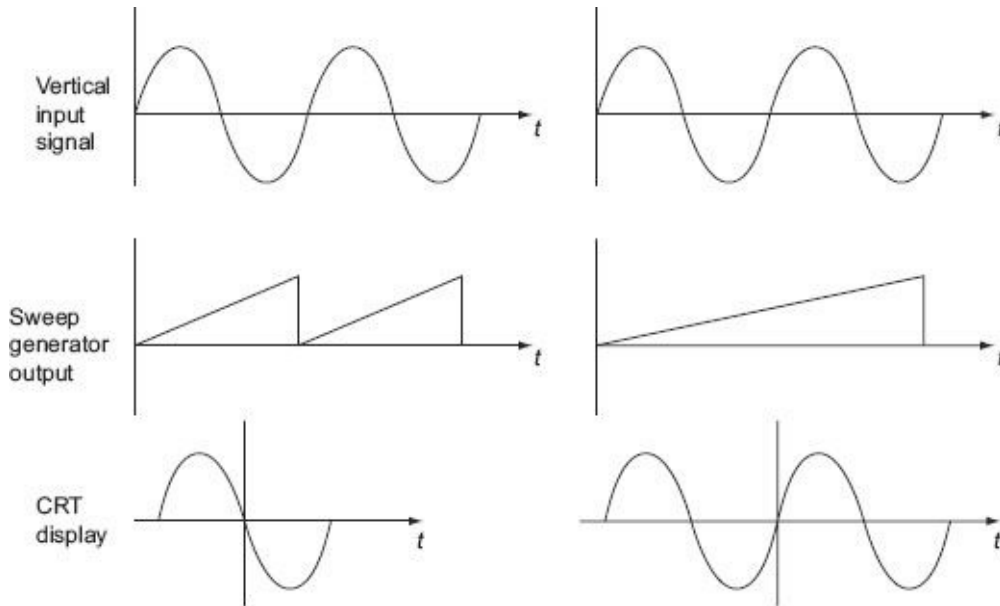

Figure 9.4 Synchronised waveforms and CRT display

9.5.2 Triggered Sweep

In free running sweep oscillators, it is not possible to observe the signals of variable frequency. The limitation is overcome by incorporating a trigger circuit into the oscilloscope as shown in Figure 9.5. The trigger circuit may receive an input from one of three sources depending on the setting of the trigger selecting switch. The input signal may come from an external source when the trigger selector switch is set to EXT, from a low amplitude ac voltage at line frequency when the switch is set to line, or from the vertical amplifier when the switch is set to INT. When set for Internal Triggering (INT), the trigger circuit receives its input from the vertical amplifier. When the vertical input signal that is being amplified by the vertical amplifier matches a certain level, the trigger circuit provides a pulse to the sweep generator, thereby ensuring that the sweep generator output is synchronised with the signal that triggers it.

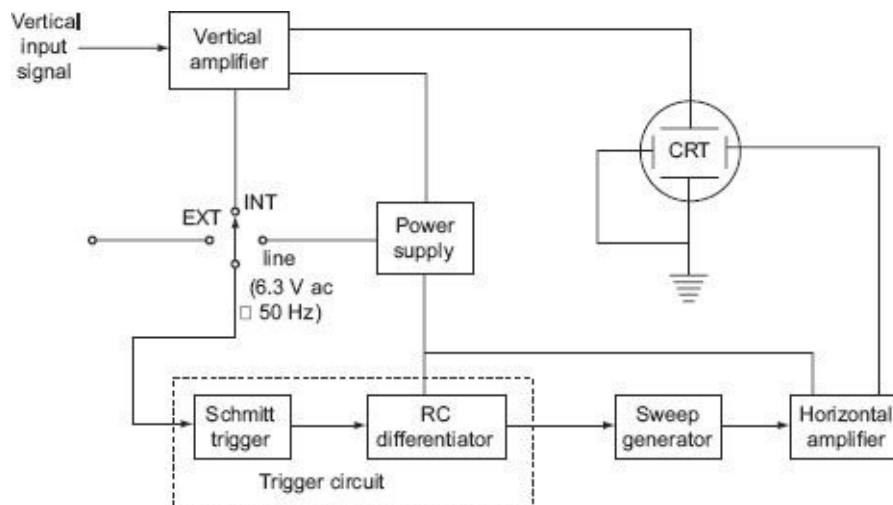

Figure 9.5 Block diagram of an oscilloscope with triggered sweep.

Schmitt trigger or a voltage level detector circuit is frequently used in the 'trigger circuit' block of Figure 9.5. Basically, the Schmitt trigger compares an input voltage, in

this case from the vertical amplifier, with a pre-set voltage.

9.6

MEASUREMENT OF ELECTRICAL QUANTITIES WITH CRO

The CRO is a very versatile instrument in laboratory for measurement of voltage, current, frequency and phase angle of any electrical quantity. But before we go ahead with the discussion on measurement of electrical quantities with a CRO, we should understand some basic oscilloscope patterns.

Basic Oscilloscope Patterns

Assume that a sinusoidal voltage is applied to the horizontal deflecting plates without any voltage signal to the vertical deflecting plates, as shown in Figure 9.6. One horizontal line will appear on the screen of the CRO. This line would be in the central position on the screen vertically.

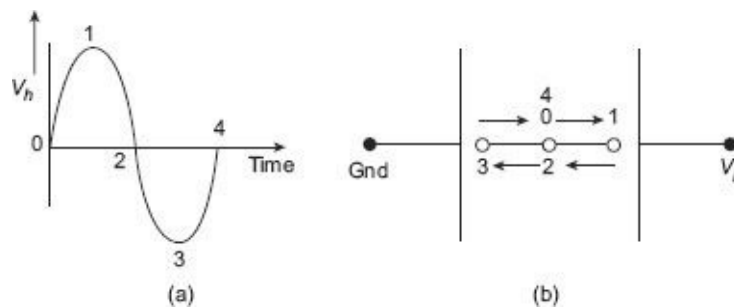

Figure 9.6 Deflection for a sinusoidal voltage applied to the horizontal deflection plates

If a sinusoidal voltage signal is applied to the vertical deflecting plates without applying any voltage signal to the horizontal deflecting plates then we get a vertical line on the screen of CRO, as shown in Figure 9.7. This line would be in the central position on the screen horizontally.

Now we would discuss what happens when both vertical and horizontal deflection plates are supplied with sinusoidal voltage signals simultaneously. Let us consider when two sinusoidal signals equal in magnitude and frequency and in phase with each other are applied to both of the horizontal and vertical deflection plates, as shown in Figure 9.8. Here we get a straight line inclined at 45° to the positive X-axis.

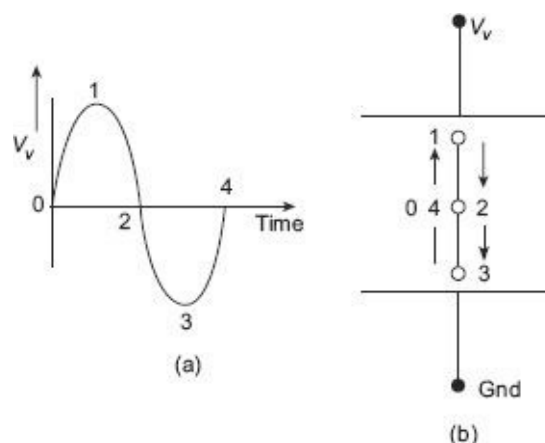

Figure 9.7 Deflection for a sinusoidal voltage applied to the vertical deflection plates

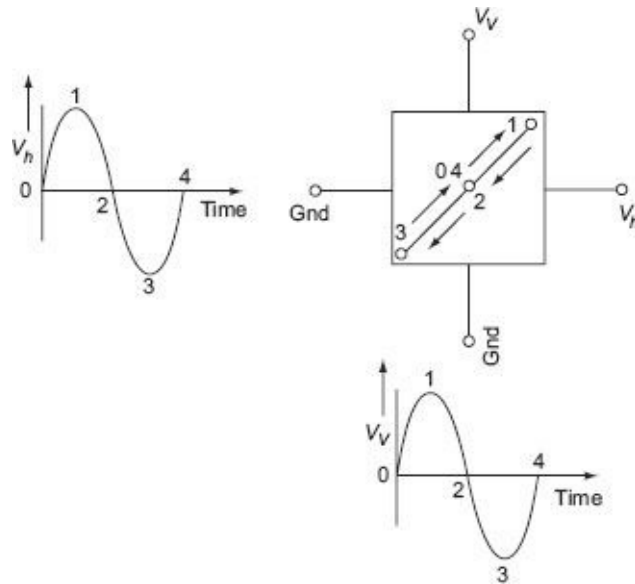

Figure 9.8 Deflection for sinusoidal voltage signals in phase and equal in magnitude and frequency, applied to horizontal and vertical deflection plates

Now let us consider a case when two sinusoidal voltage signals applied to the horizontal and vertical deflection plates are of equal magnitude and equal frequency but opposite in phase, as shown in [Figure 9.9](#). We get a straight line inclined at 135° to the positive X -axis.

In the last case, if the two sinusoidal voltage signals, 90° out of phase and of equal magnitude and equal frequency, are applied to the horizontal and vertical deflection plates, a circle would appear on the screen as shown in [Figure 9.10](#).

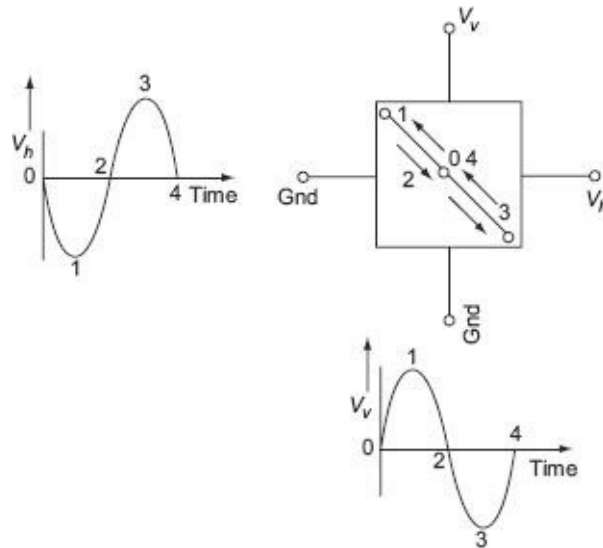

Figure 9.9 Deflection for sinusoidal voltage signals equal in magnitude and frequency but opposite in phase, applied to horizontal and vertical deflection plates

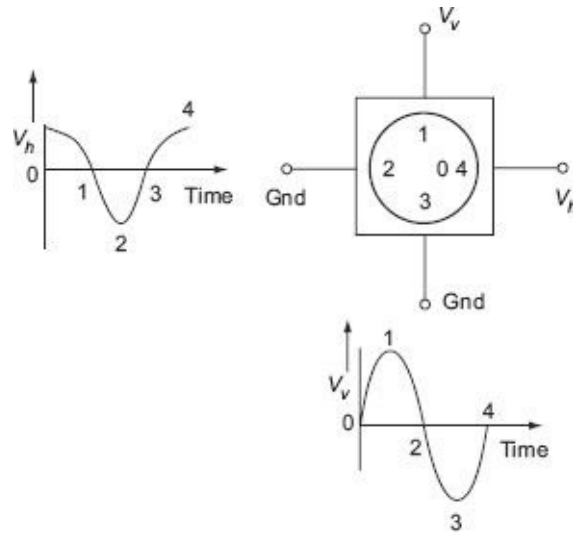

Figure 9.10 Deflection for sinusoidal voltage signals equal in magnitude and frequency but 90° out of phase, applied to horizontal and vertical deflection plates

9.7

MEASUREMENT OF VOLTAGE AND CURRENT

The expression for electrostatic deflection is $D = \frac{LI_d E_d}{2dE_a}$, where

L = distance between screen and the centre of the deflecting plates

I_d = length of deflecting plates

E_d = potential between deflecting plates

d = distance between deflecting plates

E_a = voltage of pre accelerating anode

So deflection is proportional to the deflecting-plate voltage. Thus, the cathode ray tube will measure voltage. It is used to calibrate the tube under the given operating conditions by observing the deflection produced by a known voltage. Direct voltage may be obtained from the static deflection of the spot, alternating voltage from the length of the line produced when the voltage is applied to Y-plates while no voltage is applied to X-plates. The length of the line corresponds to the peak to peak voltage. While dealing with sinusoidal voltages, the rms value is given by dividing the peak to peak voltage by $2\sqrt{2}$.

For measurement of current, the current under measurement is passed through a known non inductive resistance and the voltage drop across it is measured by CRO, as mentioned above. The current can be determined simply by dividing the voltage drop measured by the value of non inductive resistance. When the current to be measured is of very small magnitude, the voltage drop across noninductive resistance (small value) is usually amplified by a calibrated amplifier.

9.8

MEASUREMENT OF FREQUENCY

It is interesting to consider the characteristics of patterns that appear on the screen of a CRO when sinusoidal voltages are simultaneously applied to the horizontal and vertical plates. These patterns are called *Lissajous patterns*.

Lissajous patterns may be used for accurate measurement of frequency. The signal, whose frequency is to be measured, is applied to the Y-plates. An accurately calibrated standard variable frequency source is used to supply voltage to the X-plates, with the internal sweep generator switched off. The standard frequency is adjusted until the pattern appears as a circle or an ellipse, indicating that both signals are of the same frequency. Where it is not possible to adjust the standard signal frequency to the exact frequency of the unknown signal, the standard is adjusted to a multiple or submultiple of the frequency of the unknown source so that the pattern appears stationary.

Let us consider an example. Suppose sine waves are applied to X and Y plates as shown in Figure 9.11. Let the frequency of wave applied to Y plates is twice that of the voltage applied to the X plates. This means that the CRT spot travels two complete cycles in the vertical direction against one of the horizontal direction.

The two waves start at the same instant. A Lissajous pattern may be constructed in the usual way and a 8 shaped pattern with two loops is obtained. If the two waves do not start at the same instant we get different pattern for the same frequency ratio. The Lissajous pattern for the other frequency ratios can be similarly drawn. Some of these patterns are shown in Figure 9.12.

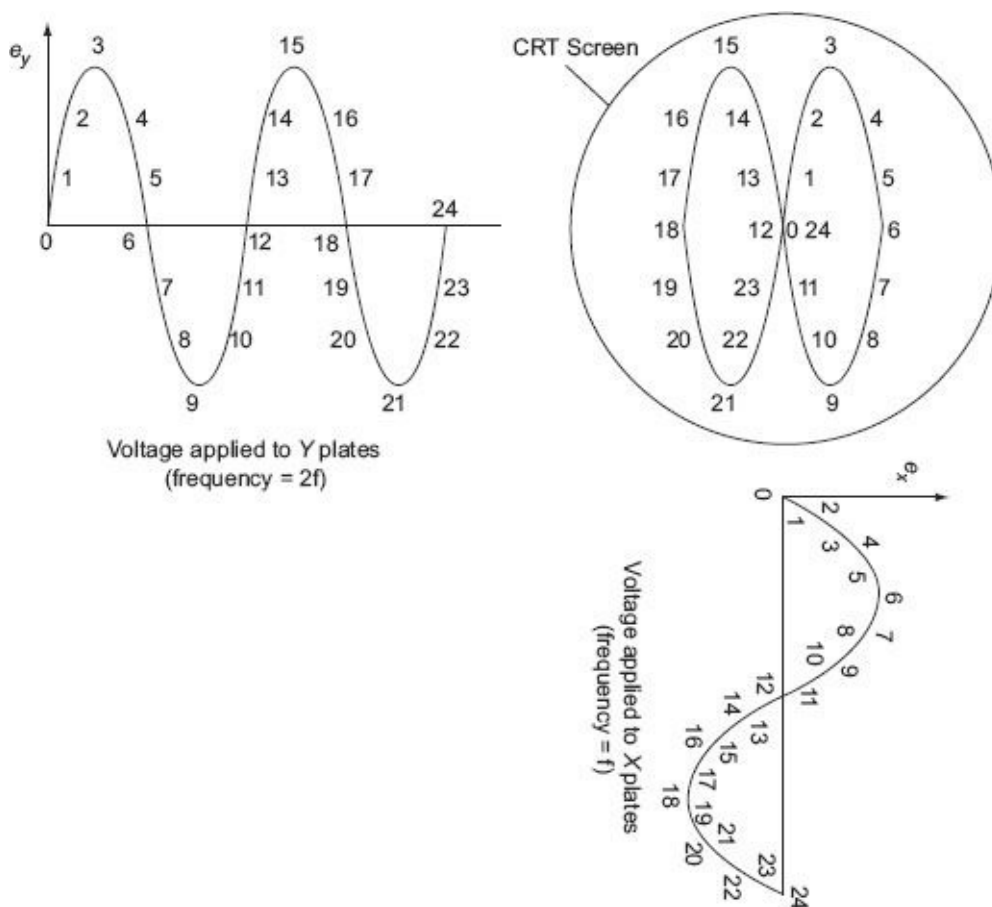

Figure 9.11 Lissajous pattern with frequency ratio 2:1

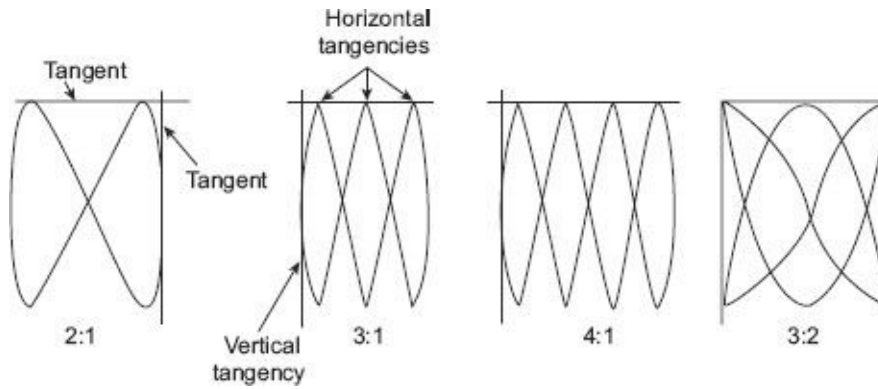

Figure 9.12 Lissajous patterns with different frequency ratio

It can be shown that for all the above cases, the ratios of the two frequencies is

$$\frac{f_y}{f_x} = \frac{\text{Number of times tangent touches top or bottom}}{\text{Number of times tangent touches either side}} = \frac{\text{Number of horizontal tangencies}}{\text{Number of vertical tangencies}}$$

where f_y = Frequency of signal applied to Y plates

f_x = Frequency of signal applied to X plates

The above rule, however, does not hold for the Lissajous patterns with free ends as shown in [Figure 9.13](#). The simple rule mentioned above needs the following modifications:

Two lines are drawn, one horizontal and the other vertical so that they do not pass through any intersections of different parts of the Lissajous curve. The number of intersections of the horizontal and the vertical lines with the Lissajous curve are individually counted. The frequency ratio is given by

$$\frac{f_y}{f_x} = \frac{\text{Number of intersections of the horizontal line with the curve}}{\text{Number of intersection of the vertical line with the curve}}$$

The applications of these rules to [Figure 9.13\(a\)](#) gives a frequency ratio $\frac{f_y}{f_x} = \frac{5}{2}$.

The modified rule is applicable in all cases whether the Lissajous pattern is open or closed.

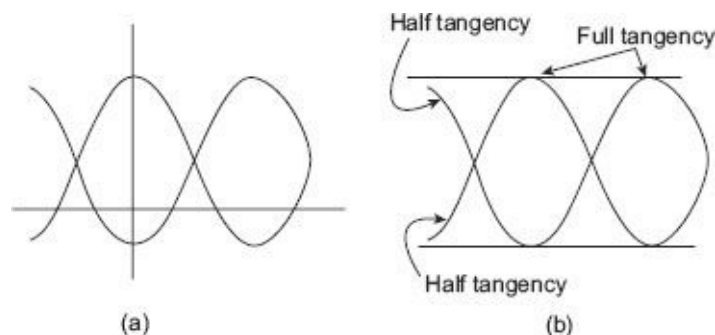

Figure 9.13 Lissajous pattern with half tangencies

The ratio of frequencies when open ended Lissajous patterns are obtained can also be found by treating the open ends as half tangencies as shown in [Figure 9.13\(b\)](#).

$$\therefore \frac{f_y}{f_x} = \frac{\text{Number of horizontal tangencies}}{\text{Number of vertical tangencies}} = \frac{2 + \frac{1}{2}}{1} = \frac{5}{2}$$

There are some restrictions on the frequencies which can be applied to the deflection plates. One obviously, is that the CRO must have the bandwidth required for these frequencies. The other restriction is that the ratio of the two frequencies should not be such as to make the pattern too complicated otherwise determination of frequency would become difficult. As a rule, ratios as high as 10:1 and as low as 10:9 can be determined comfortably.

9.9

MEASUREMENT OF PHASE DIFFERENCE

When two sinusoidal voltages of equal frequency which are in phase with each other are applied to the horizontal and vertical deflecting plates, the pattern appearing on the screen is a straight line as is clear from [Figure 9.14](#).

Thus when two equal voltages of equal frequency but with 90° phase displacement are applied to a CRO, the trace on the screen is a circle. This is shown in [Figure 9.15](#).

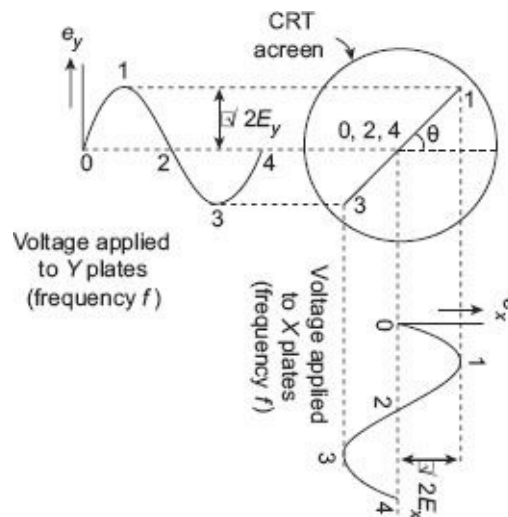

Figure 9.14 Lissajous pattern with equal frequency voltages and zero phase shift

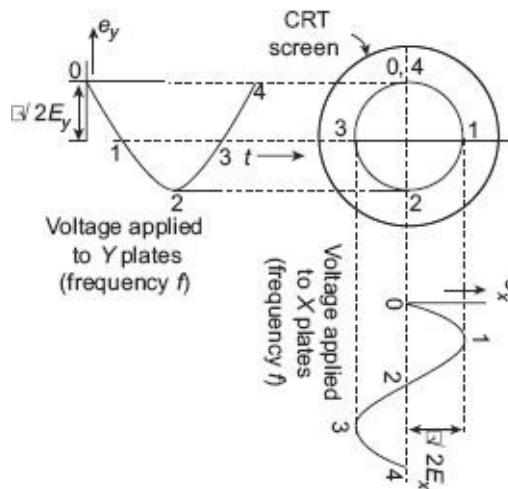

Figure 9.15 Lissajous pattern with equal voltages and a phase shift of 90°

When two equal voltages of equal frequency but with a phase shift Φ (not equal to 0 or 90°) are applied to a CRO, we obtain an ellipse as shown in [Figure 9.16](#). An ellipse is also obtained when unequal voltages of same frequency are applied to the CRO.

A number of conclusions can be drawn from the above discussions. When two sinusoidal voltages of same frequency are applied, a straight line results when the two voltages are equal and are either in phase with each other or 180° out of phase with each other. The angle formed with the horizontal is 45° when the magnitudes of voltages are equal. An increase in the vertical deflecting voltage causes the line to have an angle greater than 45° with the horizontal.

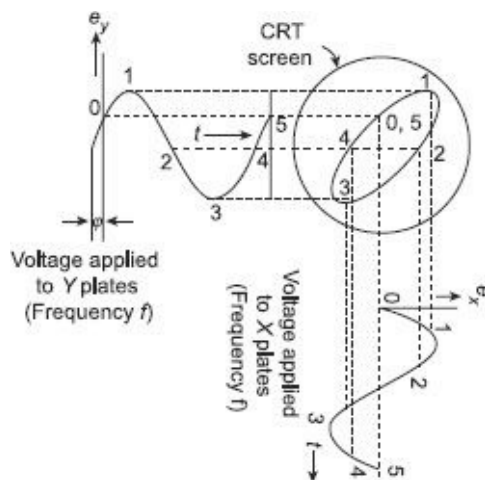

Figure 9.16 Lissajous pattern with two equal voltages of same frequency and phase shift of Φ

Two sinusoidal waveforms of the same frequency produce a Lissajous pattern which may be a straight line, a circle or an ellipse depending upon the phase and the magnitude of the voltages.

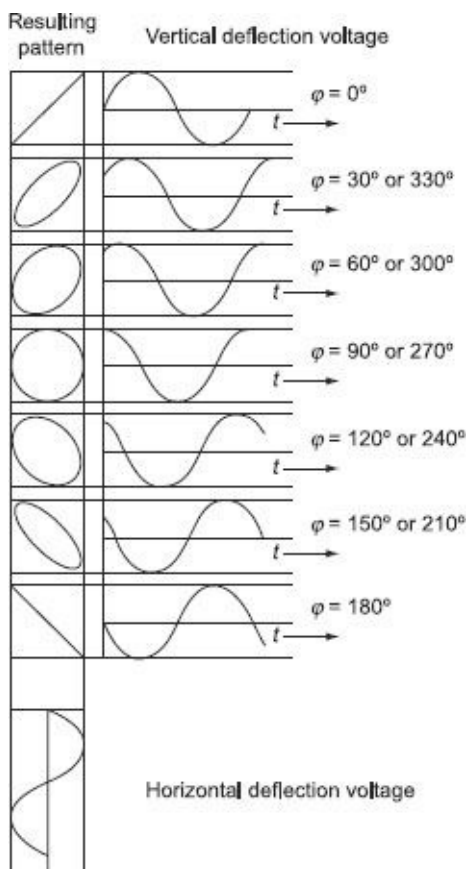

Figure 9.17 Lissajous pattern with different phase shift

A circle can be formed only when the magnitude of the two signals are equal and the phase difference between them is either 90° or 270° . However, if the two voltages are out of phase an ellipse is formed.

It is clear from [Figure 9.17](#) that for equal voltages of same frequency, progressive variation of phase voltage causes the pattern to vary from a straight diagonal line to ellipse of different eccentricities and then to a circle, after that through another series of ellipses and finally a diagonal straight line again.

Regardless of the amplitudes of the applied voltages the ellipse provides a simple means of finding phase difference between two voltages. Referring to [Figure 9.18](#), the sine of the phase angle between the voltages is given by

$$\sin \phi = \frac{Y_1}{Y_2} = \frac{X_1}{X_2}$$

For convenience, the gains of the vertical and horizontal amplifiers are adjusted so the ellipse fits exactly into a square marked by the lines of the graticule.

If the major axis of the ellipse lies in the first and third quadrants (i.e., positive slope) as in [Figure 9.18](#) (a), the phase angle is either between 0° to 90° or between 270° to 360° . When the major axis of ellipse lies in second and fourth quadrants, i.e., when its slope is negative as in [Figure 9.18](#) (b), the phase angle is either between 90° and 180° or between 180° and 270° .

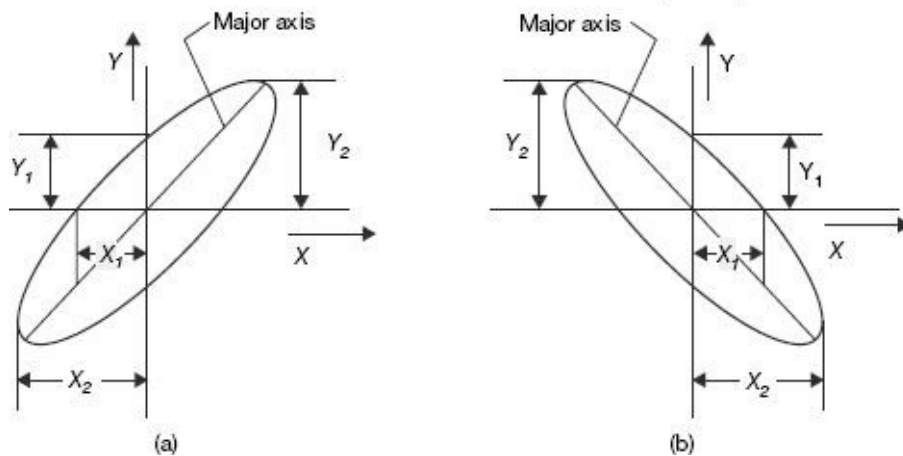

Figure 9.18 Determination of angle of phase shift

9.10

SAMPLING OSCILLOSCOPE

This oscilloscope is specially used for observing very high repetitive electrical signals by sampling the input waveform and reconstructing its shape from the sample. Such high frequency signals cannot be viewed by a conventional oscilloscope because its frequency range is limited by the gain bandwidth product of its vertical amplifier. The sampling frequency may be as low as $1/100^{\text{th}}$ of the input signal frequency, i.e., an ordinary oscilloscope having a bandwidth of 10 MHz can be used for observing input signal of frequency as high as 1000 MHz. As many as 1000 samples are used to reconstruct the original waveform.

A block diagram of a sampling oscilloscope is given in [Figure 9.19](#). The input waveform, which must be repetitive, as applied to the sampling gate. Sampling pulses momentarily bias the diodes of the balanced sampling gate in the forward direction, thereby briefly connecting the gate input capacitance to the test point. These capacitors are

slightly charged toward the voltage level of the input circuit. The capacitor voltage is amplified by a vertical amplifier and applied to the vertical deflecting plates. The sampling must be synchronised with the input signal frequency. The signal is delayed in the vertical amplifier, allowing the horizontal sweep to be initiated by the input signal.

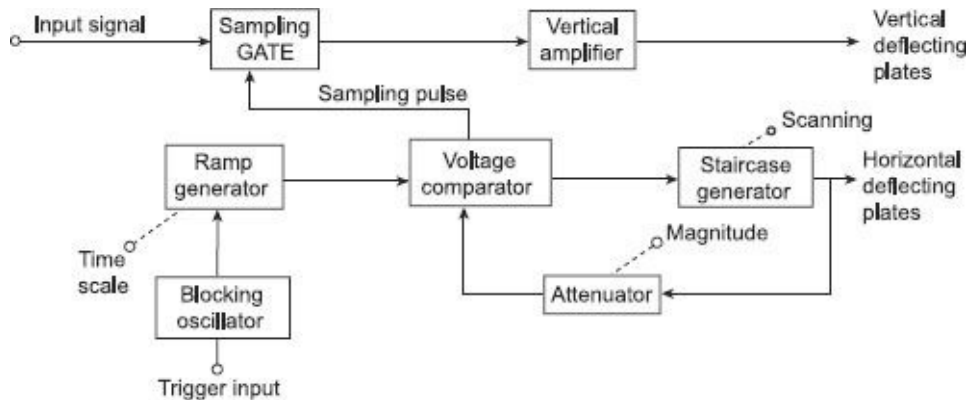

Figure 9.19 Block diagram of sampling oscilloscope

At the beginning of each sampling cycle, the trigger pulse activates an oscillator and a linear ramp voltage is generated. The ramp voltage is applied to a voltage comparator which compares the ramp voltage to a staircase generator output voltage. When the two voltages are equal in amplitude, the staircase generator is allowed to advance one step and simultaneously a sampling pulse is applied to the sampling gate. At this moment, a sample of the input voltage is taken, amplified and applied to the vertical deflecting plates.

The resolution of the final image on the screen of the CRT is determined by the size of the steps of the staircase generator. The smaller the size of these steps, the larger the number of samples and the higher the resolution of the image.

The sampling oscilloscope can be employed beyond 50 MHz into the UHF range around 500 MHz and beyond up to 10 GHz. However, sampling techniques cannot be used for the display of transients waveforms as they are not repetitive signals.

9.11

STORAGE OSCILLOSCOPE

There are two types of storage oscilloscopes, namely,

1. Analog storage oscilloscope
2. Digital storage oscilloscop

9.11.1 Analog Storage Oscilloscope

Storage targets can be distinguished from standard phosphor targets by their ability to retain a waveform pattern for a long time (10 to 15 hours after the pattern is produced on the screen). In a conventional CRT, the persistence of the phosphor varies from a few milliseconds to several seconds as a result of which, where persistence of the screen is smaller than the rate at which the signal sweeps across the screen, and the start of the display would fade before the end is written.

An analog storage oscilloscope uses the phenomenon of secondary electron emission to

build up and store electrostatic charges on the surface of an insulated target. Such oscilloscopes are widely used (i) for real-time observation of events that occur only once, and (ii) for displaying the waveform of a very low frequency (VLF) signal.

The construction of a CRT using variable persistence storage technique, called the half-tone or mesh storage CRT is shown in [Figure 9.20](#). With the variable persistence the slow swept trace can be stored on display continuously by adjusting the persistence of the CRT screen to match the sweep time.

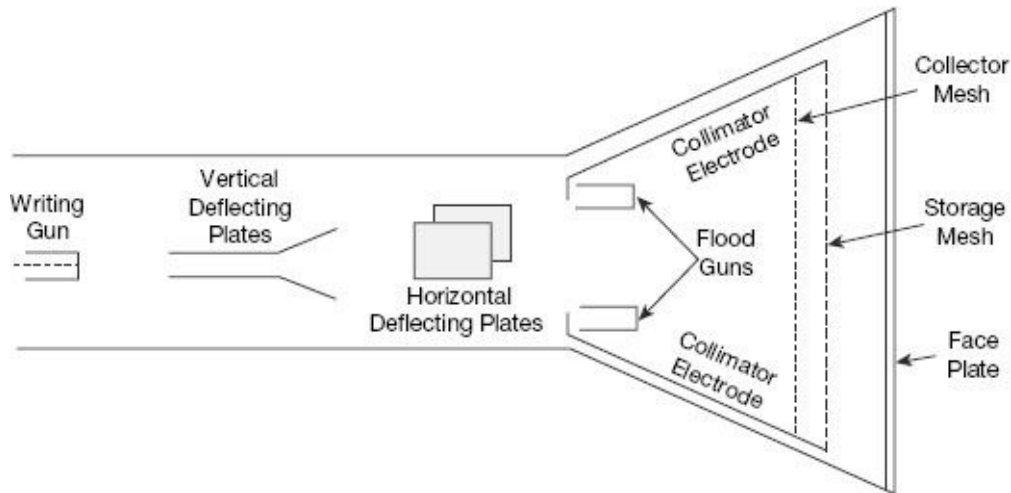

Figure 9.20 Analog storage oscilloscope

A mesh storage CRT, illustrated in [Figure 9.20](#), contains a storage mesh, flood guns and a collimator, in addition to all the elements of a standard CRT. The storage mesh that is the storage target behind the phosphor screen is a conductive mesh covered with dielectric material consisting of a thin layer of material such as magnesium fluoride. The writing gun is a high-energy electron gun similar to the conventional gun, giving a narrow focused beam which can be deflected and used to write the information to be stored. The writing gun etches a positively charged pattern on the storage mesh or target by knocking off secondary emission electrons. This positively charged pattern remains exactly in the position on the storage target where it is deposited. This is due to the excellent insulating property of the magnesium fluoride coating on the storage target. The electron beam, which is deflected in the conventional manner, both in horizontal and vertical direction, traces out the wave pattern on the storage mesh. In order to make the pattern visible, even after several hours, special electron guns, known as the flood guns are switched on.

The flood guns are of simple construction and are placed inside the CRT in a position between the direction plates and the storage target and they emit low-velocity electrons covering a large area towards the screen. The electron paths are adjusted by the collimator electrodes consisting of a conductive coating on the inside surface of the CRT. The collimator electrodes are biased so as to distribute the flood gun electrons evenly over the target surface and causes the electrons to be perpendicular to the storage mesh. Most of the flood electrons are stopped and collected by the collector mesh and, therefore, never reach the phosphor screen. Only electrons near the stored positive charge are pulled to the storage target with sufficient force to hit the phosphor screen. The CRT display, therefore, will be an exact replica of the pattern which was initially stored on the target and the display will remain visible as long as the flood gun operates. For erasing of the pattern on the storage target, a negative charge is applied to neutralise the stored positive charge.

For achieving variable persistence, the erase voltage is applied in the form of pulses instead of a steady dc voltage; by varying the width of these pulses the rate of erase is controlled.

9.11.2 Digital Storage Oscilloscope

There are a number of distinct disadvantages of the analog storage oscilloscope. These disadvantages are listed below:

1. There is a finite amount of time that the storage tube can preserve a stored waveform. Eventually, the waveform will be lost. The power to the storage tube must be present as long as the image is to be stored.
2. The trace of a storage tube is, generally, not as fine as a normal cathode ray tube. Thus, the stored trace is not as crisp as a conventional oscilloscope trace.
3. The writing rate of the storage tube is less than a conventional cathode ray tube, which limits the speed of the storage oscilloscope.
4. The storage cathode ray tube is considerably more expensive than a conventional tube and requires additional power supplies.
5. Only one image can be stored. If two traces are to be compared, they must be superimposed on the same screen and displayed together.

A superior method of trace storage is the digital storage oscilloscope (DSO). In this technique, the waveform to be stored is digitised, stored in a digital memory and retrieved for display on the storage oscilloscope. The stored waveform is continually displayed by repeatedly scanning the stored waveform and, therefore, a conventional CRT can be employed for the display and thus some of the cost of the additional circuitry for digitizing and storing the input waveform is offset. The stored display can be displayed indefinitely as long as the power is applied to the memory, which can be supplied with a small battery. The digitised waveform can be further analysed by either the oscilloscope or by loading the content of the memory into a computer. Some of the digital storage oscilloscope use 12-bit converter, giving 0.025% resolution and 0.1% accuracy on voltage and time readings, which are better than the 2.5% of analog storage oscilloscopes. Split screen capabilities (simultaneously displaying live analog traces and replayed stored ones) enable easy comparison of the two signals. Pre-trigger capability is also an important advantage. The display of stored data is possible in both amplitude versus time, and *X-Y* modes. In addition to the fast memory readout employed for CRT display, a slow readout is possible for developing hard copy with external plotters.

The only drawback of digital storage oscilloscopes is limited bandwidth by the speed of their analog-to-digital converters (ADCs). However, 20 MHz digitising rates available on some oscilloscopes yield a bandwidth of 5 MHz, which is adequate for most of the applications.

[Figure 9.21](#) gives the block diagram of a digital storage oscilloscope (DSO). It uses both of digital-to-Analog and Analog-to-Digital (DACs and ADCs) for digitising, storing and displaying analog waveforms. The overall operation is controlled and synchronised by the control circuits. Which usually have microprocessor executing a control program stored in Read-Only Memory (ROM). The data acquisition portion of the system contains

a sample-and-hold (S/H) and an analog-to-digital converter that repetitively samples and digitizes the input signal at a rate determined by the sample clock, and transmits the digitized data to memory for storage. The control circuit makes sure that successive data points are stored in successive memory locations by continually updating the memory's *address counter*.

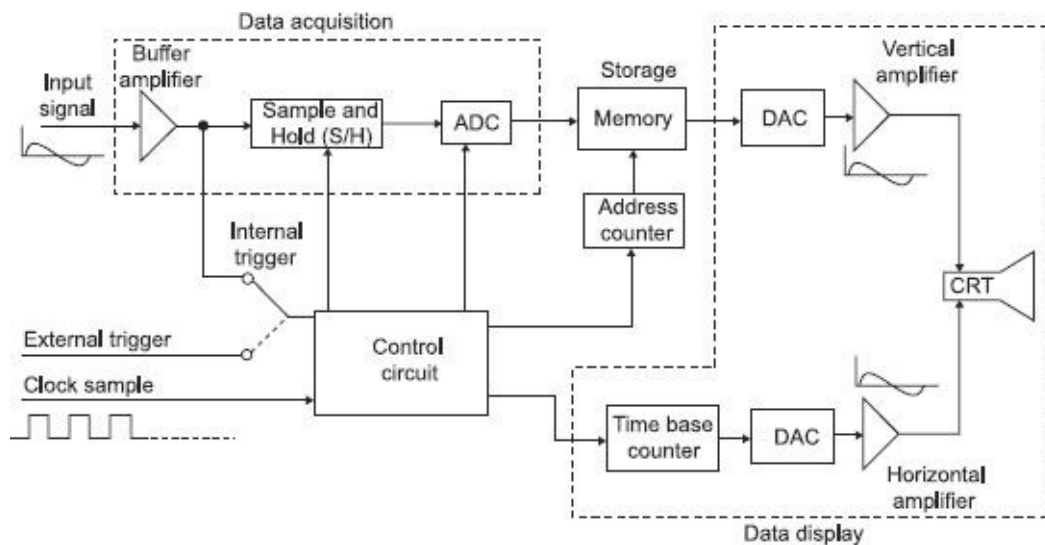

Figure 9.21 Block diagram of Digital Storage Oscilloscope (DSO)

When memory is full, the next data point from the ADC is stored in the first memory location writing over the old data, and so on for successive data points. This data acquisition and the storage process continue until the control circuit receives a trigger signal from either the input waveform (internal trigger) or an external trigger source. When the triggering occurs, the system stops acquiring data further and enters the display mode of operation, in which all or part of the memory data is repetitively displayed on the Cathode Ray Tube (CRT).

In display operation two DACs are employed for providing the vertical and horizontal deflecting voltages for the cathode ray tube. Data from memory produce the vertical deflection of the electron beam, while the time base counter provides the horizontal deflection in the form of a staircase sweep signal. The control circuits synchronize the display operation by incrementing the memory address counter and the time base counter at the same time so that each horizontal step of the electron beam is accompanied by a new data value from the memory to the vertical DAC. The counters are continuously recycled so that the stored data points are repetitively re-plotted on the screen of the CRT. The screen display consists of discrete dots representing the various data points but the number of dots is usually so large (typically 1000 or more) that they tend to blend together and appear to be a continuous waveform.

The display operation is transmitted when the operator presses a front panel button that commends the digital storage oscilloscope to begin a new data acquisition cycle.

9.12

MULTI-INPUT OSCILLOSCOPES

Modern oscilloscopes have the multi-input facility. They display the multi input

simultaneously. Two inputs is most generally used, although four and eight inputs are available for special applications. There are two primary types: single beam and dual beam. A single beam can be converted into several traces. A dual beam, on the other hand may also subsequently be converted into a further number of traces. Two input oscilloscopes are described in this chapter, although the principles are applicable to any number of inputs.

9.12.1 Dual Trace Oscilloscopes

The block diagram of a dual trace oscilloscope is shown in Figure 9.22. There are two separate vertical input channels, A and B, and these use separate attenuator and preamplifier stages. Therefore the amplitude of each input, as viewed on the oscilloscope, can be individually controlled. After preamplification, the two channels meet at the electronic switch. This has the ability to pass one channel at a time into the vertical amplifier, via the delay line.

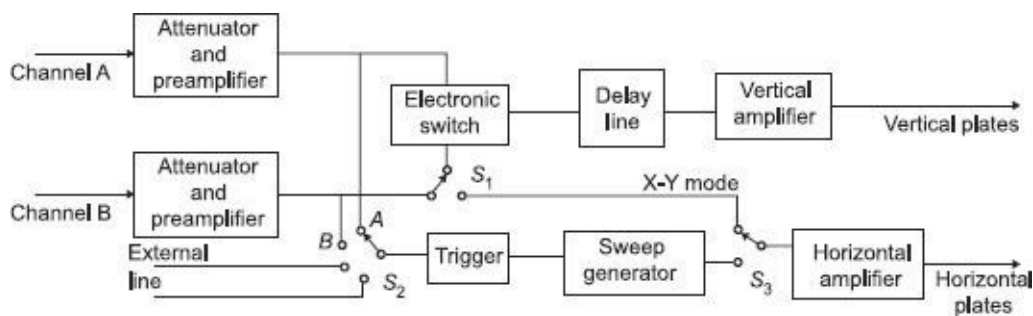

Figure 9.22 Block diagram of a dual trace oscilloscope

There are two common operating modes for the electronic switch, called *alternate* and *chop*, and these are selected from the instrument's front panel. The alternate mode is illustrated in Figure 9.23. In this figure, the electronic switch alternates between channels A and B, letting each through for one cycle of the horizontal sweep. The display is blanked during the flyback and hold-off periods, as in the conventional oscilloscope. Provided the sweep speed is much greater than the decay time of the CRT phosphor, the screen will show a stable of both the waveform at channels A and B. The alternate mode cannot be used for displaying very low-frequency signals.

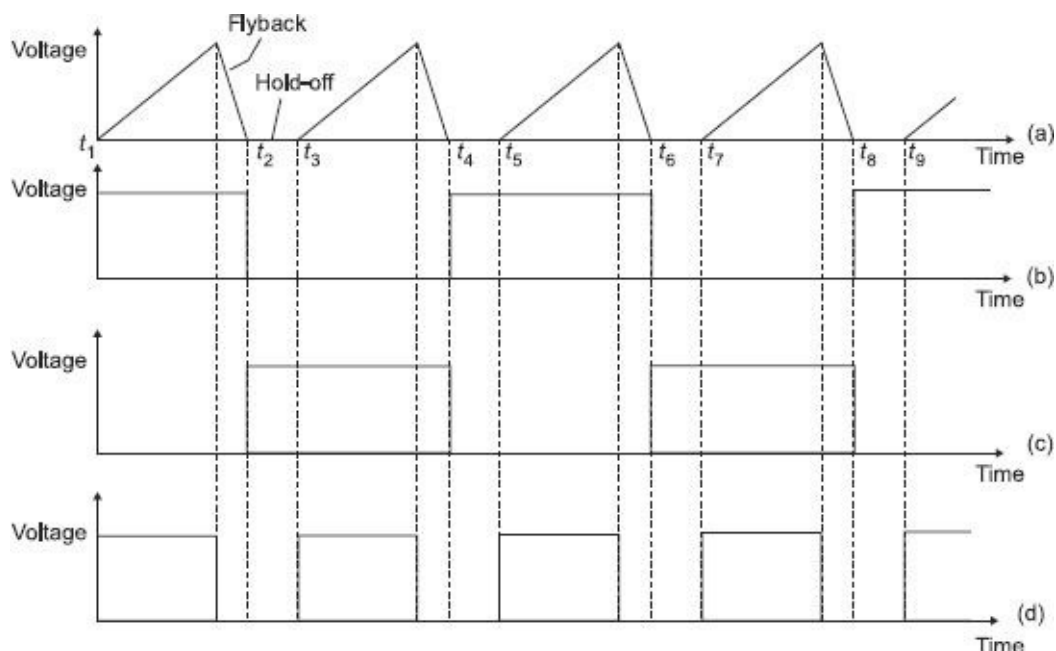

Figure 9.23 Waveforms for a dual channel oscilloscope operating in alternating mode: (a) Horizontal Sweep voltage (b) Voltage to channel A (c) Voltage to channel B, (d) Grid control voltage

The chopped operating mode of the electronic switch is shown in Figure 9.24. In this mode the electronics switch free runs at a high frequency of the order of 100 kHz to 500 kHz. The result is that small segments from channels A and B are connected alternately to the vertical amplifier, and displaying on the screen. Provided the chopping rate is much faster than the horizontal sweep rate, the display will show a continuous line for each channel. If the sweep rate approaches the chopping rate then the individual segments will be visible, and the alternate mode should now be used.

The time base circuit shown in Figure 9.22 is similar to that of a single input oscilloscope. Switch S_2 allow the circuit to be triggered on either the A or B channel waveforms, or on line frequency, or on an external signal. The horizontal amplifier can be fed from the sweep generator, or the B channel via switch S_1 . This is the X-Y mode and the oscilloscope operates from channel A as the vertical signal and channel B as the horizontal signal, giving very accurate X-Y measurements. Several operating modes can be selected from the front panel for display, such as channel A only, channel B only, channels A and B as two traces, and signals $A + B$, $A - B$, $B - A$ or $-(A + B)$ as a single trace.

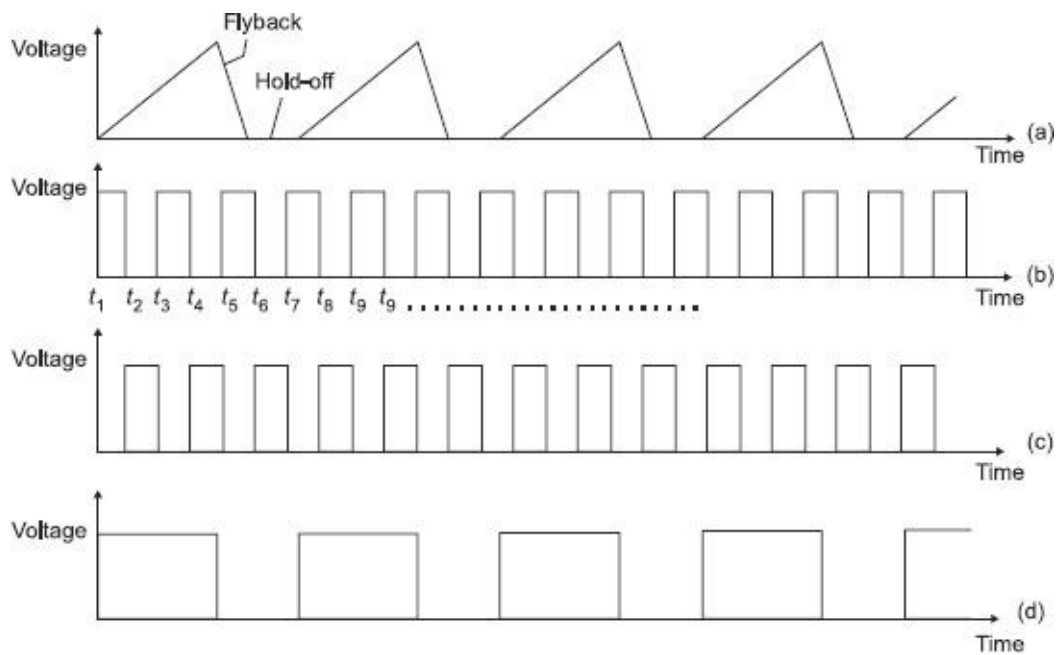

Figure 9.24 Waveforms for a dual channel oscilloscope operating in chopped mode: (a) Horizontal sweep voltage (b) Voltage to channel A (c) Voltage to channel B, (d) Grid control voltage

9.12.2 Dual Beam Oscilloscopes

The dual trace oscilloscope cannot capture two fast transient events, as it cannot switch quickly enough between traces. The dual beam oscilloscope has two separate electron beams, and therefore two completely separate vertical channels, as in Figure 9.23. The two channels may have a common time base system, as in Figure 9.22, or they may have independent time base circuits, as in Figure 9.25. An independent time base allows different sweeps rates for the two channels but increases the size and weight of the oscilloscope.

Two methods are used for generating the two electron beams within the CRT. The first method used a double gun tube. This allows the brightness and focus of each beam to be

controlled separately but it is bulkier than a split beam tube.

In the second method, known as split beam, a single electron gun is used. A horizontal splitter plate is placed between the last anode and the Y deflection plates. This plate is held at the same potential as the anode, and it goes along the length of the tube, between the two vertical deflection plates. It therefore isolates the two channels. The split beam arrangement has half the brightness of a single beam, which has disadvantages at high frequency operation. An alternative method of splitting the beam, which improves its brightness, is to have two apertures in the last anode, instead of one, so that two beams emerge from it.

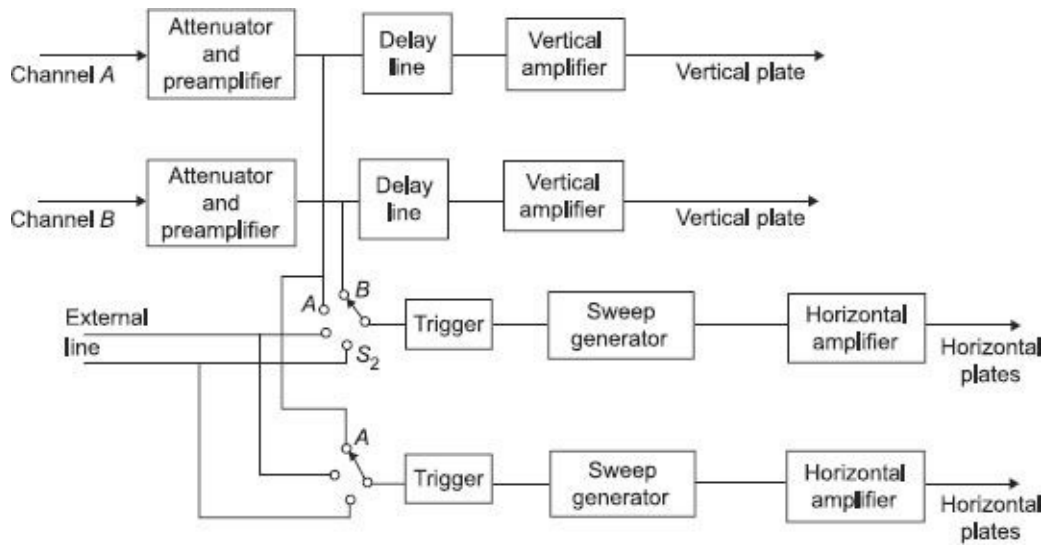

Figure 9.25 Block diagram of a dual beam oscilloscope with independent time base

The disadvantage of the split beam construction is that the two displays may have noticeably different brightness, if operated at widely spaced sweep speeds. The brightness and focus controls also affect the two traces at the same time.

9.13

FREQUENCY LIMITATION OF CRO

Deflection of electron beam on the screen in Y direction is given by $D = \frac{Ll_d E_d}{2dE_a}$, where E_d is the potential between deflecting plates. In this derivation, the plate voltage is assumed constant during the motion of the electrons through the deflecting field. If the voltage applied to the vertical deflecting plates change during the transit time of the electrons through the horizontal plates, the deflection sensitivity gets decreased.

Transit time $t_1 = \frac{l}{V_{ox}}$,

where l = length of deflecting plates

V_{ox} = velocity of electron while entering the field of deflecting plates.

The transit time impose a limitation of the upper frequency limit. An upper frequency is defined as that frequency at which the transit time is equal to one quarter (1/4) of the period of the voltage applied to vertical plates.

$$\therefore \text{upper limiting frequency} = f_c = \frac{1}{4t_1} = \frac{V_{ax}}{4l}$$

The frequency range of the oscilloscope can be increased by sub-dividing the deflecting plates in a number of sections in the path of electron beam. The voltage being measured is applied to the vertical plates through an iterative network, whose propagation time corresponds to the velocity of electron; thereby the voltage applied to the vertical plates is made to synchronise with the velocity of the beam. The use of this technique allows the CRO to be used up to frequencies of 500 MHz and above.

EXERCISE

Objective-type Questions

- The time base signal in a CRO is
 - a sinusoidal signal
 - a sawtooth signal
 - a square wave signal
 - a triangular wave signal
- In CRT aquadag carries
 - secondary emission electrons
 - sweep voltage
 - aqueous solution of graphite
 - none of these
- In a CRO, the sawtooth voltage is applied at the
 - cathode
 - accelerating anode
 - vertical deflecting plates
 - horizontal deflecting plates
- The purpose of the synchronising control in a CRO is to
 - adjust the amplitude of display
 - control the intensity of the spot
 - focus the spot on the screen
 - lock the display of signal
- Retrace period for an ideal sawtooth waveform is
 - 0 second
 - equal to tracing period
 - infinite
 - none of these
- In a CRT, the highest positive potential is given to
 - cathode
 - focusing electrodes
 - vertical deflecting plates
 - post-deflection acceleration anode

7. The X and Y inputs of a CRO are respectively $V \sin \omega t$ and $-V \sin \omega t$. The resulting Lissajous pattern will be
- a straight line
 - a circle
 - the shape of 8
 - an ellipse
8. The patterns used to measure phase and frequency with a cathode ray oscilloscope are called
- Faraday's pattern
 - Ohm's patterns
 - Lissajous pattern
 - Phillips pattern
9. The voltage $10 \cos \omega t$ and $V \cos (\omega t + \alpha)$ are applied to the X and Y plates of a CRO. The Lissajous figure observed on the screen is a straight line of 60° to the positive axis. Then
- $V = 10, \alpha = 60^\circ$
 - $V = 10, \alpha = 0^\circ$
 - $V = 10\sqrt{3}, \alpha = 60^\circ$
 - $V = 10\sqrt{3}, \alpha = 0^\circ$
10. Sampling oscilloscopes are specially designed to measure
- very high frequency
 - very low frequency
 - microwave frequency
 - none of these
11. Which of the following statements is not correct for a storage-type oscilloscope?
- Secondary emission electrons etch a positively charged pattern.
 - The flood guns used for display, emit high velocity electrons.
 - The flood guns are placed between the deflection plates and storage target.
 - The storage target is a conductive mesh covered with magnesium fluoride.
12. In a digital oscilloscope, the A/D converters are usually
- ramp type
 - flash type
 - integrating type
 - successive approximate type
13. A double beam oscilloscope has
- two screens
 - two electron guns
 - two different phosphor coatings
 - one waveform divided into two parts
14. Two equal voltages of same frequency applied to the X and Y plates of a CRO, produce a circle on the screen. The phase difference between the two voltages is
- 150°
 - 90°
 - 60°
 - 30°

15. The Lissajous pattern on a CRO screen is shown in the given figure:

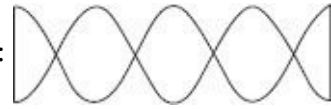

The frequency

ratio of the vertical signal to the horizontal one is

- (a) 3 : 2
- (b) 2 : 3
- (c) 5 : 1
- (d) 1 : 5

Answers

1. (b)	2. (c)	3. (d)	4. (d)	5. (a)	6. (d)	7. (a)
8. (c)	9. (a)	10. (a)	11. (b)	12. (c)	13. (b)	14. (b)
15. (c)						

Short-answer Questions

1. What is meant by the *deflection factor* and *deflection sensitivity* of a CRO? What is aquadag?
2. Discuss the advantages and disadvantages of analog and digital type of oscilloscope.
3. Explain the functioning of the time base generator in a CRO with proper diagram.
4. Describe the phenomenon of synchronisation of vertical input signal to its sweep generator.
5. Discuss the *triggered sweep* in a CRO.
6. Why is a CRO considered one of the most important tools in the field of modern electronics? What is the heart of a CRO?
7. How is the frequency of an ac signal measured with the help of CRO?
8. How is the phase difference between two signals measured with the help of the CRO?
9. "The focusing system of a CRO named as an electrostatic lens." Explain.
10. What are the differences between dual trace and dual beam oscilloscopes?

Long-answer Questions

1. (a) Draw the block diagram of a CRO and explain the different components.
 (b) The deflection sensitivity of an oscilloscope is 35 V/cm. If the distance from the deflection plates to the CRT screen is 16 cm, the length of the deflection plates is 2.5 cm and the distance between the deflection plates is 1.2 cm, what is the acceleration anode voltage?
2. (a) Derive an expression for the vertical deflection on the screen of a cathode ray tube in terms of length of plates, separation distance, accelerating voltage and distance of screen from the origin.
 (b) In a CRT, the distance between the deflecting plates is 1.0 cm, the length of the deflecting plates is 4.5 cm and the distance of the screen from the centre of the deflecting plates is 33 cm. If the accelerating voltage supply is 300 volt, calculate deflecting sensitivity of the tube.
3. What are Lissajous patterns? From the Lissajous patterns, how can the frequency and the phase difference be measured?
4. What are the advantages of dual trace over double beam for multitrace oscilloscopes? Explain the working of a dual trace CRO with the help of the proper block diagram.
5. Explain the working principle of a sampling oscilloscope with the help of proper block diagram. What precaution should be taken when using the sampling oscilloscope?
6. Draw the block diagram of a storage-type oscilloscope and explain the working of each block. How does the digital oscilloscope differ from the conventional analog storage oscilloscope?
7. Write short notes on the following.
 - (a) Vertical amplifier

- (b) Electromagnetic focusing
- (c) Delay line
- (d) Frequency and phase measurement by CRO
- (e) High frequency oscilloscope
- (f) Free running sweep
- (g) Oscilloscope limitations

10.1

INTRODUCTION

Nowadays everyone is familiar with analog signals. They are used for the movement of an electromagnetic meter to measure voltage, current, resistance, power, etc. Although the bridges and multipliers use electrical components for these measurements, the instruments described use no amplifiers to increase the sensitivity of the measurements. The heart of these instruments was the d'Arsonval meter, which typically cannot be constructed with a full-scale sensitivity of less than about $50\ \mu\text{A}$. Any measurement system using the d'Arsonval meter, without amplifiers, must obtain at least $50\ \mu\text{A}$ from the circuit under test for a full-scale deflection. For the measurement of currents of less than $50\ \mu\text{A}$ full scale, an amplifier must be employed. The resistance of a sensitive meter, such as a $50\ \mu\text{A}$ meter for a volt-ohm-milliammeter, is of the order of a few hundred ohms and represents a small but finite amount of power. As an example, $50\ \mu\text{A}$ through a $200\ \Omega$ meter represents $\frac{1}{2}$ microwatt. This represents the power required for a meter for full-scale deflection and does not represent the power dissipated in the series resistor, and thus the total power required by the example meter would be greater than $\frac{1}{2}\ \mu\text{W}$ and would depend on the voltage range. This does not sound like much power, but many electronics circuits cannot tolerate this much power being drained from them. So the electronics instruments are required for measuring very small current and voltage.

Electronic instruments, mainly electronic voltmeters, used either transistors or vacuum tubes. The later one is called the Vacuum Tube Voltmeter (VTVM) and the former one is called the Transistorised Voltmeter (TVM). In almost every field of electronics, VTVMs have been replaced by TVMs because of their numerous advantages. In TVM, due to the absence of a heating element, warm-up time is not required. It is portable due to the light weight of the transistor. VTVMs cannot measure current due to the very high resistance whereas due to the low resistance of the TVM, it can measure the current directly from the circuit. VTVMs also cannot measure high-frequency signals. The only disadvantage of TVM over VTVM is that the TVM has very low input impedance. But using FET (Field Effect Transistor) in the input stage of the voltmeter overcomes this low-impedance problem, because an FET offers input impedance almost equal to a vacuum tube.

10.2

MERITS AND DEMERITS OF DIGITAL INSTRUMENTS OVER ANALOG ONES

Although electronics are usually more costly than electrical instruments but are becoming more and more popular because of their various advantages over conventional ones, some

of the main advantages are discussed below:

1. Detection of Low Level Signals As indicated above analog instruments use PMMC movement for indication. This movement cannot be constructed with a full scale sensitivity of less than 50 mA. Any measurement using a PMMC movement must draw a current of 50 mA from the measured quantity for its operation for full scale deflection if conventional voltmeters are used. This would produce great loading effects especially in electronic and communication circuits. Electronic voltmeter avoids the loading errors by supplying the power required for measurement by using external circuits like amplifiers. The amplifiers not only supply power for the operation but make it possible for low level signals, which produce a current less than 50 mA for full scale deflection, to be detected which otherwise cannot be detected in the absence of amplifiers. Let us examine the loading effect. A typical meter has a resistance of 200 Ω and its operating current at full scale is 50 mA. This means the power consumed is only $(50 \times 10^{-6})^2 \times 200 = 0.5$ mW. This is extremely a low power for the power circuits but not for many electronic and communication circuits. If this power is taken from the measurand, the signal gets greatly distorted in case power level the circuit is very small and to offset this power is supplied from outside through use of amplifiers.

Let us have a look at the voltage. A meter with 200 Ω internal resistance and full scale current of 50 mA will have full scale voltage range of $50 \times 10^{-6} \times 200 = 10$ mV. Now in case of lower ranges of voltages have to be measured, the use of a voltage amplifier becomes absolutely necessary. This is only possible through use of electronic voltmeters which allow the use of an amplifier. Therefore, it is possible to measure currents below 50 mA, voltages below 10 mV and keep drawn the power drainage below 0.5 mW by using electronic voltmeters through use of amplifiers which is otherwise not possible with conventional types of meter using PMMC movement. For the case of ac measurements, the use of an amplifier for detection of low level signals is even more necessary for sensitive measurements.

2. High Input Impedance A conventional PMMC voltmeter is a rugged and an accurate instrument, but it suffers from certain disadvantages. The principle problem is that it lacks both high sensitivity and high input resistance. It has a sensitivity of 20 kW/V with a 0 – 0.5 V range and has an input resistance of only 10 kW at its 0.5 V range with the result it has a full scale current of 50 mA which loads the measurand considerably. In electronics and communication circuits even this low value of current may not be tolerable on account of the fact that these circuits have very low operating currents. The electronic voltmeter (EVM), on the other hand, can have input resistances from 10 MW to 100 MW with the input resistance remaining constant over all ranges instead of being different at different ranges, the EVM gives for less loading effects.

3. Low Power Consumption Electronic voltmeters utilize the amplifying properties of vacuum tubes and transistors and therefore the power required for operating the instrument can be supplied from an auxiliary source. Thus, while the circuit whose voltage is being measured controls the sensing element of the voltmeter, the power drawn from the circuit under measurement is very small or even negligible. This can be interpreted as the voltmeter circuit has very high input impedance. This feature of electronic voltmeter is indispensable for voltage measurement in many high impedance circuits such as

encountered in communicating equipments.

4.High Frequency Range The most important feature of electronic voltmeters is that their response can be made practically independent of frequency within extremely wide limits. Some electronic voltmeters permit the measurement of voltage from direct current to frequency of the order of hundreds of MHz. the high frequency range may also be attributed to low input capacitance of most electronics devices. The capacitance may be of the order of a few pF.

5.Better Resolution Resolution (smallest reading perceivable) of analog instruments is limited by space on the scale markings and also by ability of the human operator to read such small deviations in scale markings. Whereas in a digital instrument, the measured value is displayed directly on a LED or LCD panel whose resolution is solely determined by resolution of the analog to digital converter (ADC). Use of 12 bit (or higher) ADC can make a digital instrument to read as small as 0.001 V in 0 – 5 V range.

6.Storage Facility Digital instruments have an additional optional advantage that their readings can be stored for future reference. Since the value displayed is obtained through an ADC, the digital data can be easily stored in a microprocessor or PC memory. Such storage facility can only be made available in analog instruments by the use of chart recorders where the pointer has a ink source that keeps on marking the values on a roll of moving paper.

7.Accuracy Since there are very few moving parts (or even no moving parts) in the digital instruments, in general they are usually more accurate than the analog instruments. Even the human error involved in reading these instruments is very less, which adds to the accuracy of digital instruments. However, overall accuracy of a digital instrument will largely depend on accuracies of the large number of individual electronic components used for building the instrument.

In addition, digital instruments are more user friendly as they are easy to read, takes up smaller space, suitable for mass production, and also sometimes less costly.

Disadvantages of Digital Instruments

1. Effects on noise in more predominant on digital instruments than analog instruments. Analog instruments, due to inertia of its moving parts, normally remain insensitive to fast varying noise, while digital instruments continue to show erratic variations in presence of noise.
2. Analog instruments have higher overload capacity than digital instruments. The sensitive electronic components used in digital instruments are more prone to damage in case of even momentary overloads.
3. Digital instruments can sometimes loose its reliability and tend to indicate erratic values due to faulty electronic circuit components or damaged display.
4. Digital instruments and their internal electronic components are very much sensitive to external atmospheric conditions. In case of high humidity and corrosive atmosphere the internal parts may get damaged and indicate the faulty values.

The performance characteristics of digital instruments are resolution, accuracy, linear errors, monotonicity, settling time and temperature sensitivity.

1. Resolution

It is the reciprocal of the number of discrete steps in the Digital to Analog (D/A) converter input. Resolution defines the smallest increment in voltage that can be discerned. Evidently resolution depends on the number of bits, i.e., the smallest increment in output voltage is determined by the Least Significant Bit (LSB). Percentage resolution is $[1/(2^N - 1)] \times 100$, where N is the number of bits.

2. Accuracy

It is a measure of the difference between actual output and expected output. It is expressed as a percentage of the maximum output voltage. If the maximum output voltage (or full-scale deflection) is 5 volt and accuracy is $\pm 0.1\%$, then the maximum error is $(0.1/100) \times 5 = 0.005$ volt or 5 mV. Ideally the accuracy should be better than $\pm 1/2$ of LSB. In a 8-bit converter, LSB is $1/255$ or 0.39% of full scale. The accuracy should be better than 0.2%.

3. Linear Error

Linearity means that equal increments in digital input of digital instruments should result in equal increment in analog output voltage. If the values of resistances are very accurate and the other components are also ideal, there would be perfectly linear relation between output and input and output–input graph would be a straight line. Because of the fact that resistances used in the circuit have some tolerance, a perfectly linear relation between input and output is not obtained. A special case of linear error is offset error which is the output voltage when digital input is 0000.

4. Monotonicity

A Digital to Analog (D/A) converter is monotonic if it does not take any reverse step when it is sequenced over the entire range of input bits.

5. Settling Time

When the digital input signal changes, it is desirable that analog output signal should immediately show the new output value. However, in actual practice, the D/A converter takes some time to settle at the new position of the output voltage. Settling time is defined as the time taken by the D/A converter to settle within $\pm 1/2$ LSB of its final value when a change in input digital signal occurs. The finite time taken to settle down to new value is due to the transients and oscillations in the output voltage. Figure

6. Temperature Sensitivity

The reference voltage supplied to the resistors of a D/A converter are all temperature sensitive. Therefore, the analog output voltage depends, at least to some extent, on the temperature. The temperature sensitivity of the offset voltage and the bias current of OP-AMP also affect the output voltage. The range of temperature sensitivity for a D/A

converter is from about ± 50 to ± 1.5 ppm/ $^{\circ}\text{C}$.

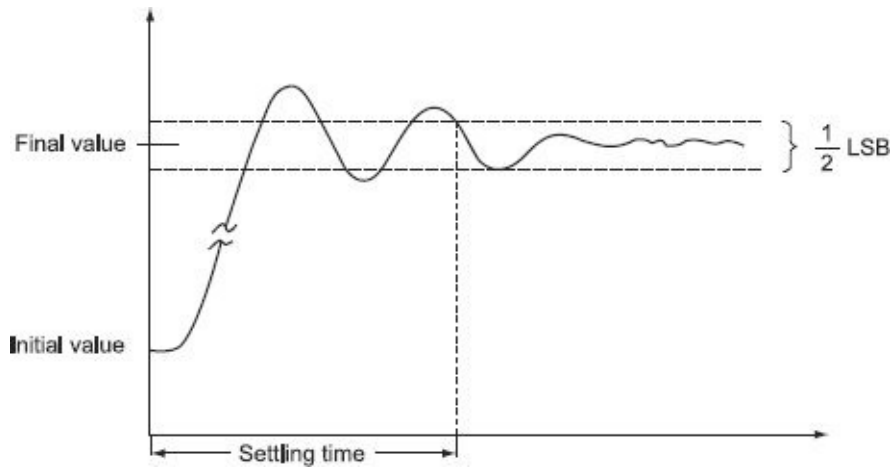

Figure 10.1 *Settling time of a digital instrument*

10.4

DIGITAL MULTIMETER

A digital multimeter is an electronic instrument which can measure very precisely the dc and ac voltage, current (dc and ac), and resistance. All quantities other than dc voltage is first converted into an equivalent dc voltage by some device and then measured with the help of digital voltmeter.

The block diagram of a digital multimeter is shown in [Figure 10.2](#). The procedures of measurement of different quantities are described below.

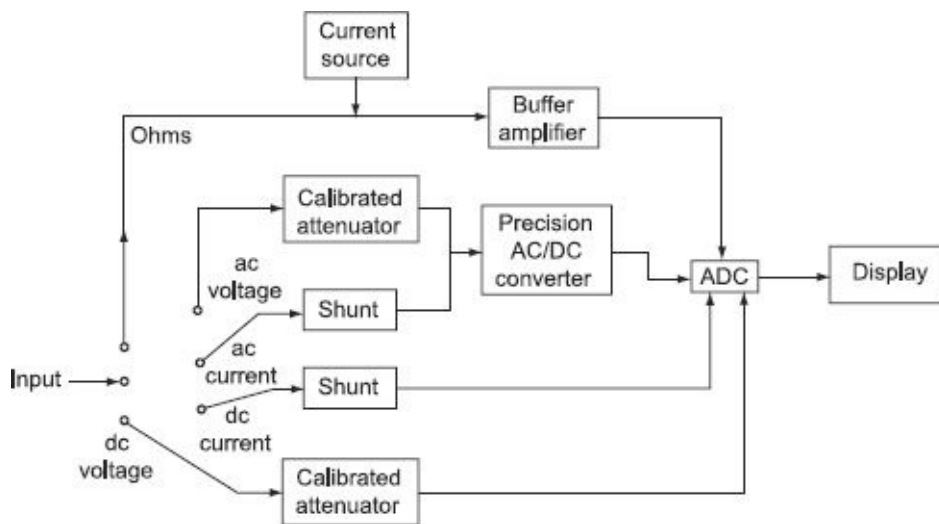

Figure 10.2 *Block diagram of a digital multimeter*

For measurement of ac voltage, the input voltage, is fed through a calibrated, compensated attenuator, to a precision full-wave rectifier circuit followed by a ripple reduction filter. The resulting dc is fed to an Analog Digital Converter (ADC) and the subsequent display system. Many manufacturers provide the same attenuator for both ac and dc measurements.

For current measurement, the drop across an internal calibrated shunt is measured directly by the ADC in the 'dc current mode', and after ac to dc conversion in the 'ac current mode'. This drop is often in the range of 200 mV (corresponding to full scale).

Due to the lack of precision in the ac–dc conversions, the accuracy in the ac range is generally of the order of 0.2 to 0.5%. In addition, the measurement range is often limited to about 50 Hz at the lower frequency end due to the ripple in the rectified signal becoming a non-negligible percentage of the display and hence results in fluctuation of the displayed number. At the higher frequency end, deterioration of the performance of the ADC converter limits the accuracy. In ac measurement the reading is often average or rms values of the unknown current. Sometimes for measurement of current, a current-to-voltage converter may also be used, as block diagram in [Figure 10.3](#).

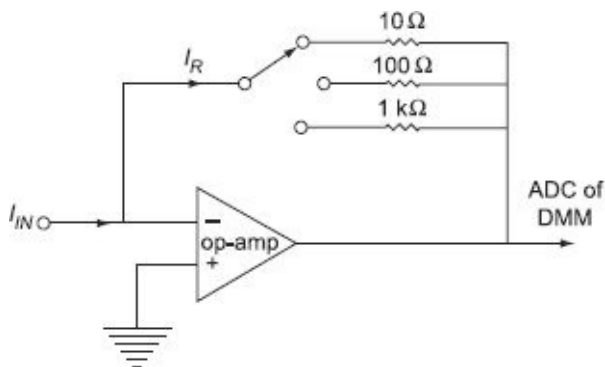

Figure 10.3 Block diagram of a current-to-voltage converter

The current under measurement is applied to the summing junction at the input of the op-amp. The current in the feedback resistor I_R is equal to the input current I_{IN} because of very high input impedance of the op-amp. The current I_R causes a voltage drop across one of the resistors, which is proportional to the input current I_{IN} . Different resistors are employed for different ranges.

For resistance measurement the digital multimeter operates by measuring the voltage across the externally connected resistance, resulting from a current forced through it from a calibrated internal current source. The accuracy of the resistance measurement is of the order of 0.1 to 0.5% depending on the accuracy and stability of the internal current sources. The accuracy may be proper in the highest range which is often about 10 to 20 MΩ. In the lowest range, the full scale may be nearly equal to >200 Ω with a resolution of about 0.01 Ω for a 4½ digit digital multimeter. In this range of resistance measurement, the effect of the load resistance will have to be carefully considered.

Table 10.1 Comparison between analog and digital multimeter

Analog Multimeter	Digital Multimeter
No external power supply required.	An external power supply is required.
Visual indication of change in reading is better observable.	Less observable.
Less effect of electronic noise.	More affected by electronic noise.
Less isolation problems.	More isolation problems.
It has less accuracy.	Highly accurate instrument.
Interface of the output with external equipment is not possible.	Possible to connect an external instrument with the output reading.
Simple in construction.	Very complicated in construction.
Big in size.	Small in size.

Low cost.

More costlier instrument.

The output is ambiguous in many times.

Unambiguous reading due to digital indication.

10.5

DIGITAL FREQUENCY METER

A frequency counter is a digital instrument that can measure and display the frequency of any periodic waveform. It operates on the principle of gating the unknown input signal into the counter for a predetermined time. For example, if the unknown input signal were gated into the counter for exactly 1 second, the number of counts allowed into the counter would be precisely the frequency of the input signal. The term *gated* comes from the fact that an AND or an OR gate is employed for allowing the unknown input signal into the counter to be accumulated.

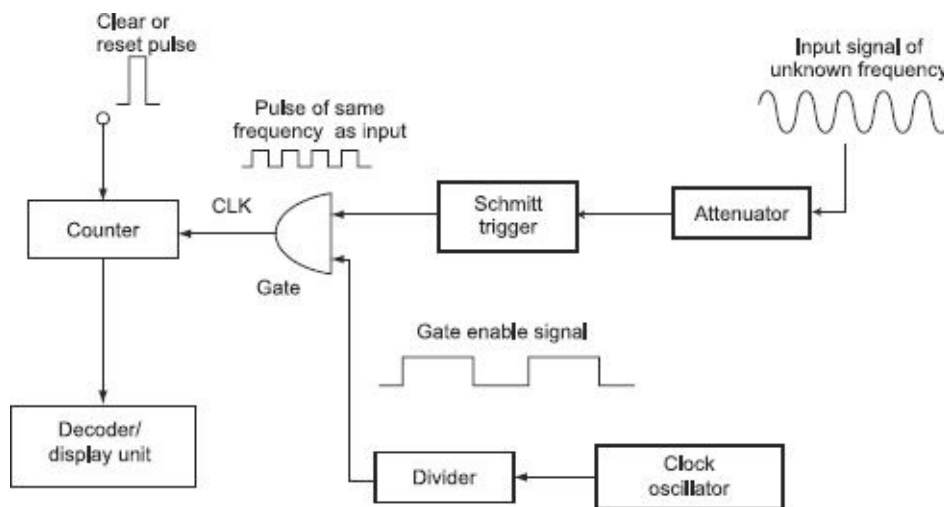

Figure 10.4 Block diagram of frequency counter

One of the most straightforward methods of constructing a frequency counter is shown in [Figure 10.4](#) in simplified form. It consists of a counter with its associated display/decoder circuitry, clock oscillator, a divider and an AND gate. The counter is usually made up of cascaded Binary Coded Decimal (BCD) counters and the display/decoder unit converts the BCD outputs into a decimal display for easy monitoring. A GATE ENABLE signal of known time period is generated with a clock oscillator and a divider circuit and is applied to one leg of an AND gate. The unknown signal is applied to the other leg of the AND gate and acts as the clock for the counter. The counter advances one count for each transition of the unknown signal, and at the end of the known time interval, the contents of the counter will be equal to the number of periods of the unknown input signal that have occurred during time interval, t . In other words, the counter contents will be proportional to the frequency of the unknown input signal. For instance if the gate signal is of a time of exactly 1 second and the unknown input signal is a 600-Hz square wave, at the end of 1 second the counter will count up to 600, which is exactly the frequency of the unknown input signal.

The waveform in [Figure 10.5](#) shows that a clear pulse is applied to the counter at t_0 to set the counter at zero. Prior to t_1 , the GATE ENABLE signal is LOW, and so the output of the AND gate will be LOW and the counter will not be counting. The GATE ENABLE

goes HIGH from t_1 to t_2 and during this time interval $t (= t_2 - t_1)$, the unknown input signal pulses will pass through the AND gate and will be counted by the counter. After t_2 , the AND gate output will be again LOW and the counter will stop counting. Thus, the counter will have counted the number of pulses that occurred during the time interval, t of the GATE ENABLE SIGNAL, and the resulting contents of the counter are a direct measure of the frequency of the input signal.

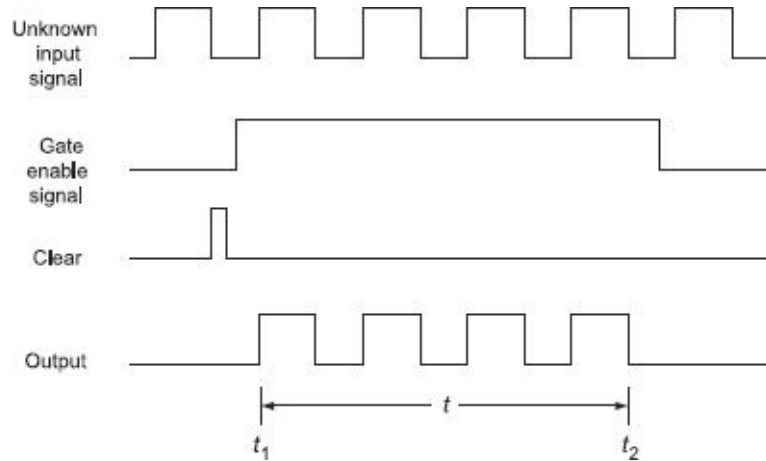

Figure 10.5 Different waveforms in a frequency counter

The accuracy of the measurement depends almost entirely on the time interval of the GATE ENABLE signal, which needs to be controlled very accurately. A commonly used method for obtaining very accurate GATE ENABLE signal is shown in Figure 10.6. A crystal controlled oscillator is employed for generating a very accurate 100 kHz waveform, which is shaped into the square pulses and fed to a series of decade counters that are being used to successively divide this 100 kHz frequency by 10. The frequencies at the outputs of each decade counter are as accurate as the crystal frequency.

The switch is used to select one of the decade counter output frequencies to be supplied to a single Flip-flop to be divided by 2. For instance in switch position 1, the 1 Hz pulses are supplied to flip-flop Q, which acts as a toggle flip-flop so that its output will be a square wave with a period if $T = 2 s$ and a T pulse duration, $t = \frac{T}{2} = 1 s$. In position 2, the pulse duration would be 0.1s, and so on in other positions of the select switch.

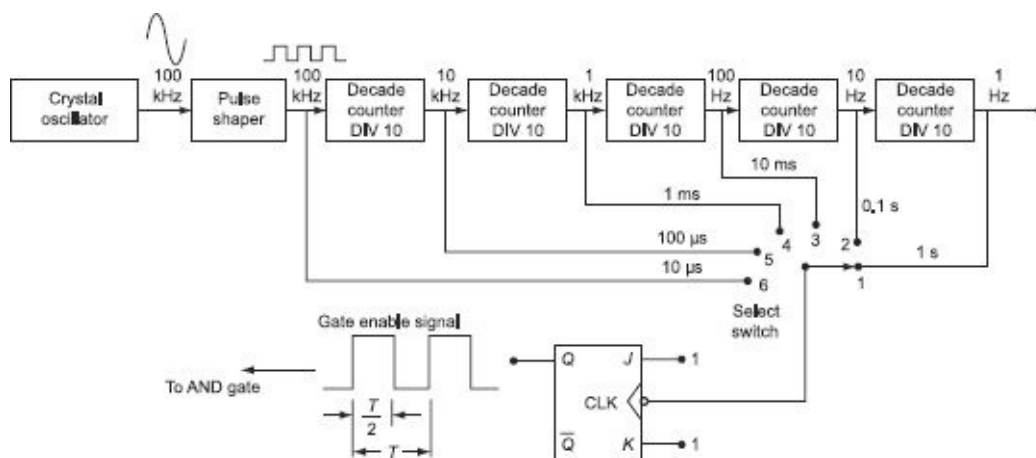

Figure 10.6 Method of obtaining very accurate GATE ENABLE signal

The Digital Voltmeter (DVM) displays measurement of ac or dc voltages as discrete numbers instead of a pointer deflection on a continuous scale as in analog instruments. It is a versatile and accurate instrument that is employed in many laboratory measurement applications. Because of development and perfection of IC modules, their size, power consumptions and cost of the digital voltmeters has been drastically reduced and, therefore, DVMs are widely used for all measurement purposes.

The block diagram of a simple digital voltmeter is shown in Figure 10.7. The unknown signal is fed to the pulse generator which generates a pulse whose width is directly proportional to the input unknown voltage.

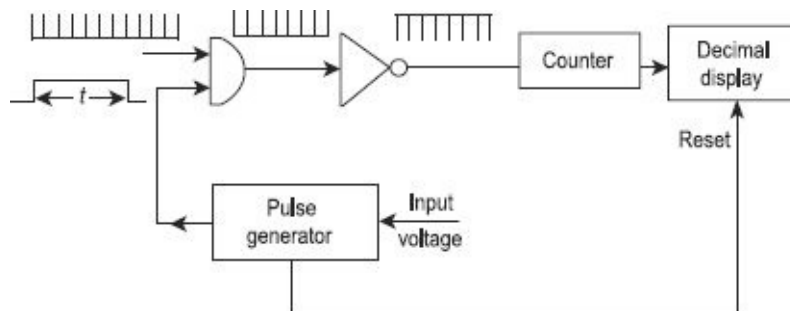

Figure 10.7 Block diagram of DVM

The output of the pulse generator is applied to one leg of an AND gate. The input signal to the other leg of the AND gate is a train of pulses. The output of the AND gate is, thus, a positive trigger train of duration t second and the inverter converts it into a negative trigger train. The counter counts the number of triggers in t seconds which is proportional to the voltage under measurement. Thus, the counter can be calibrated to indicate voltage in volts directly.

Thus, the DVMs described above is an Analog to Digital Converter (ADC) which converts an analog signal into a train of pulses, the number of which is proportional to the input voltage. So a digital voltmeter can be made by using any one of the analog to digital conversion methods and can be represented by a block diagram shown in Figure 10.8. So the DVMs can be classified on the basis of ADCs used.

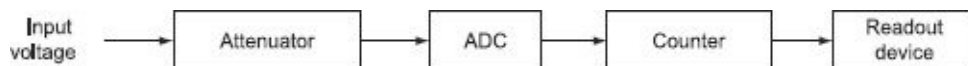

Figure 10.8 Representation of DVM using blocks

The input range of the DVM may vary from ± 1.00000 V to ± 1000.00 V and its limiting accuracy is as high as ± 0.005 percent of the reading. Its resolution may be 1 part in 10^6 , giving 1 μ V reading of the 1 V input range. It has high input resistance of the order of 10 M Ω and input capacitance of the order of 40 pF.

Digital voltmeters employing different analog to digital conversion methods are described below:

10.6.1 Ramp-Type DVM

The operation of a ramp-type DVM is based on the measurement of the time that a linear

ramp voltage takes to change from the level of the input voltage to zero voltage or vice-versa. This time interval is measured with an electronic time interval counter and the count is displayed as a number of digits on the electronic indicating tubes of the voltmeter output readouts.

The operating principle and block diagram of a ramp-type DVM are given in [Figures 10.9\(a\)](#) and [10.9\(b\)](#) respectively.

At the start of measurement, a ramp voltage is initiated, this voltage can be positive going or negative going. In [Figure 10.9\(a\)](#), negative going voltage ramp is illustrated.

The ramp voltage is continuously compared with the voltage under measurement (unknown voltage). At the instant the value of ramp voltage becomes equal to the voltage under measurement, a coincidence circuit, called the *input comparator*, generates a pulse which opens a gate, as shown in [Figure 10.9\(b\)](#). The ramp voltage continues to fall till it reaches zero value (or ground value). At this instant another comparator, called the *ground comparator*, generates a stop pulse. The output pulse from this ground comparator closes the gate. The time duration of the gate opening is proportional to the value of the dc input voltage.

The time elapsed between opening and closing the gate is t , as illustrated in [Figure 10.9\(a\)](#). During this time interval pulses from a clock pulse oscillator pass through the gate and are counted and displayed. The decimal number indicated by the readout is a measure of the value of the input voltage.

The sample rate multivibrator determines the rate at which the measurement cycles are initiated. The sample rate circuit provides an initiating pulse for the ramp generator to start its next ramp voltage. At the same time a reset pulse is generated, which resets the counter to zero state.

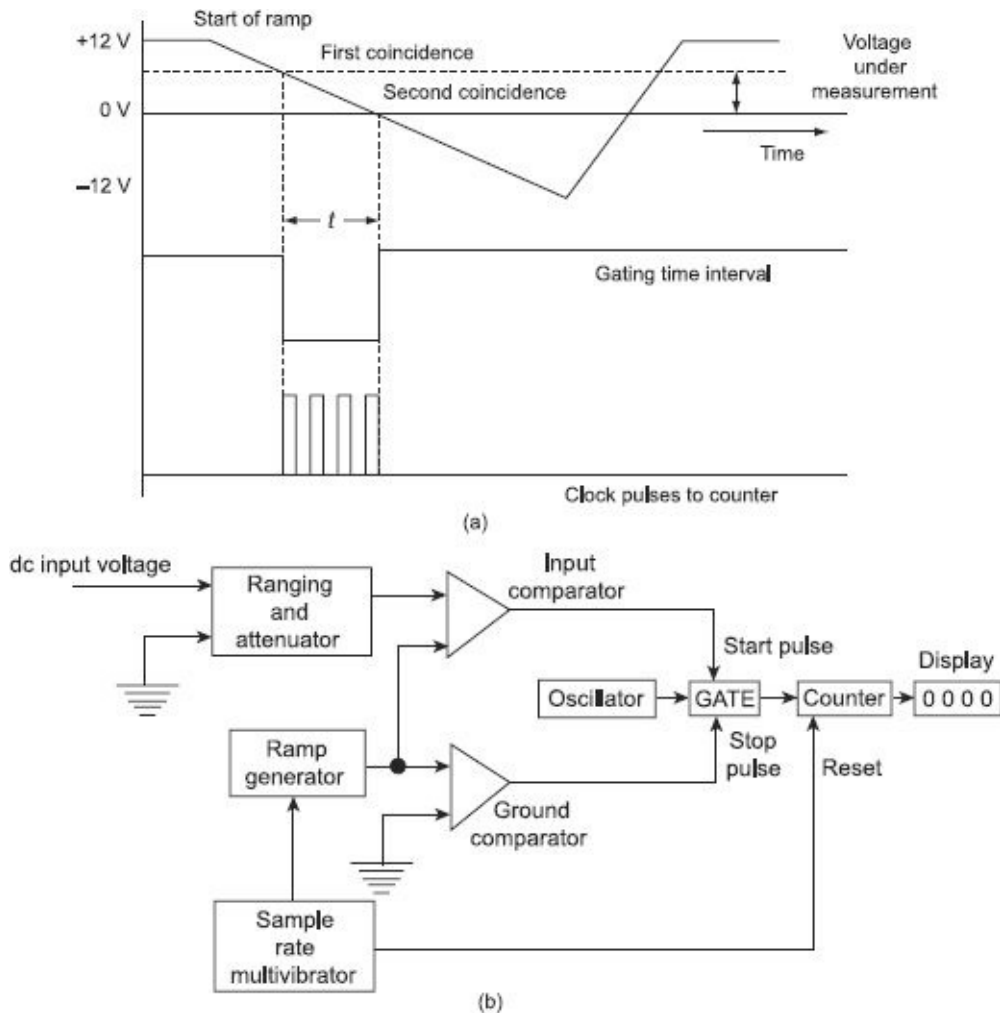

Figure 10.9 (a) Voltage-to-time conversion (b) Block diagram of a ramp-type DVM

10.6.2 Dual-Slope Integrating-Type DVM

The block diagram of a dual-slope integrating-type DVM is given in Figure 10.10(a). The dual slope ADC consists of five blocks namely an OP-AMP employed as an integrator, a level comparator, a basic clock for generating time pulses, a set of decimal counter and a block of logic circuitry.

For a fixed time interval (usually, the full count range of the counter), the analog input voltage to be measured, is applied through the switch S to the integrator which raises the voltage in the comparator to some negative value, as illustrated in Figure 10.10(b), obviously at the end of fixed time interval the voltage from the integrator will be greater in magnitude for larger input voltage, i.e., rate of increase of voltage or slope is proportional to the analog input voltage. At the end of the fixed count interval, the count is set at zero and the switch S is shifted to the reference voltage V_{REF} of opposite polarity. The integrator output or input to the capacitor then starts increasing at a fixed rate, as illustrated in

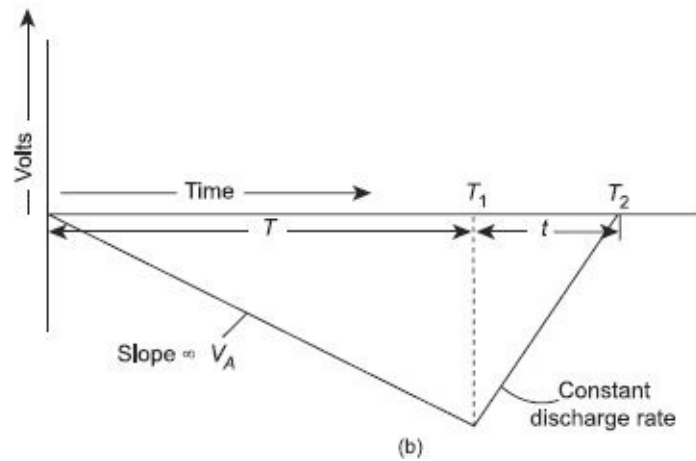
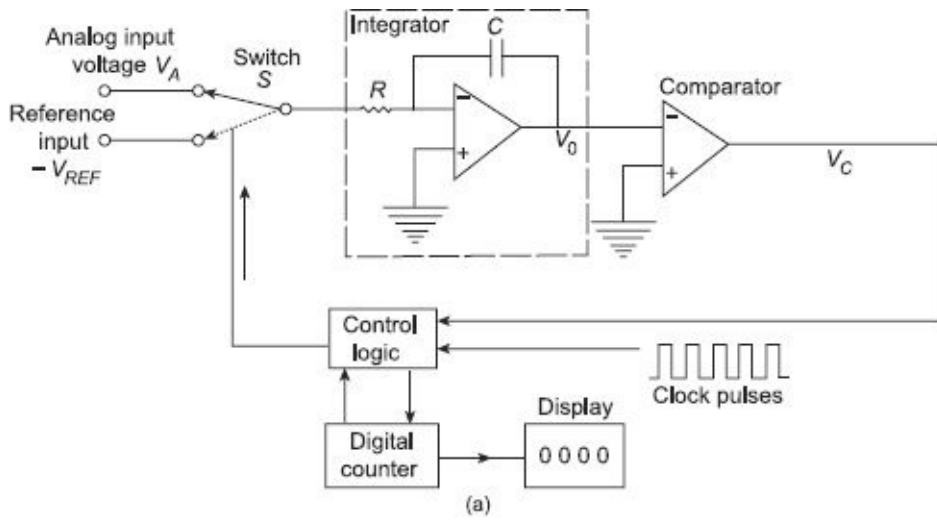

Figure 10.10 (a) Block diagram of a Dual-Slope Integrating-type DVM
 (b) Principle of operation of dual-slope-type DVM

Figure 10.10(b). The counter advances during this time. The integrator output voltage increases at a fixed rate until it rises above the comparator reference voltage, at which the control logic receives a signal (the comparator output) to stop the count. The pulse counted by the counter thus has a direct relation with the input voltage V_A .

During charging, the output voltage V_0 is given as

$$V_0 = \frac{-1}{RC} \int_0^t V_A dt = \frac{-V_A t}{RC}$$

$$\text{at } t = T_1 \text{ (charging time) the value of the integrator output voltage } V_0 = \frac{-V_A T_1}{RC} \quad (10.1)$$

Now the capacitor C has already a voltage of $\frac{-V_A T_1}{RC}$ (initial voltage),

During discharging, the output voltage is given as

$$V_0 = \text{Initial voltage of the capacitor} + \frac{-1}{RC} \int_0^t (-V_{REF}) dt = \frac{-V_A T_1}{RC} + \frac{V_{REF} t}{RC}$$

At $t = T_2$ (the time measured by the counter), the output voltage of the integrator becomes zero

$$\text{So, } 0 = \frac{-V_A T_1}{RC} + \frac{V_{REF} T_2}{RC}$$

$$\text{or, } V_A = V_{REF} \frac{T_2}{T_1} \quad (10.2)$$

Thus, the count shown by the counter (T_2) is proportional to the input voltage to be measured, V_A . The display unit displays the measured voltage.

The averaging characteristics and cancellation of errors that usually limit the performance of a ramp-type DVM are the main advantages of dual slope integrating type DVM. The integration characteristics provide the average value of the input signal during the period of first integration. Consequently, disturbances, such as spurious noise pulses, are minimised. Long-term drifts in the time constant as may result from temperature variations or aging, do not affect conversion accuracy. Also, long-term alternations in clock frequency have no effect.

10.6.3 Integrating-Type DVM (Voltage to Frequency Conversion)

Such a digital voltmeter makes use of an integration technique which employs a voltage to frequency (V/f) conversion. This voltmeter indicates the true average value of the unknown voltage over a fixed measuring period.

An analog voltage can be converted into digital form by producing pulses whose frequency is proportional to the analog input voltage. These pulses are counted by a counter for a fixed duration and the reading of the counter will be proportional to the frequency of the pulses, and hence, to the analog voltage.

A block diagram of a voltage to frequency ADC is shown in [Figure 10.11](#). The analog input voltage V_A is applied to an integrator which in turn produces a ramp signal whose slope is proportional to the input voltage. When the output voltage V_0 attains a certain value (a preset threshold level), a trigger pulse is produced and also a current pulse is generated which is used to discharge the integrator capacitor C . Now a new ramp is initiated. The time between successive threshold level crossings is inversely proportional to the slope of the ramp. Since the ramp slope is proportional to the input analog voltage V_A , the frequency of the output pulses from the comparator is, therefore, directly proportional to the input analog voltage. This output frequency may be measured with the help of a digital frequency counter.

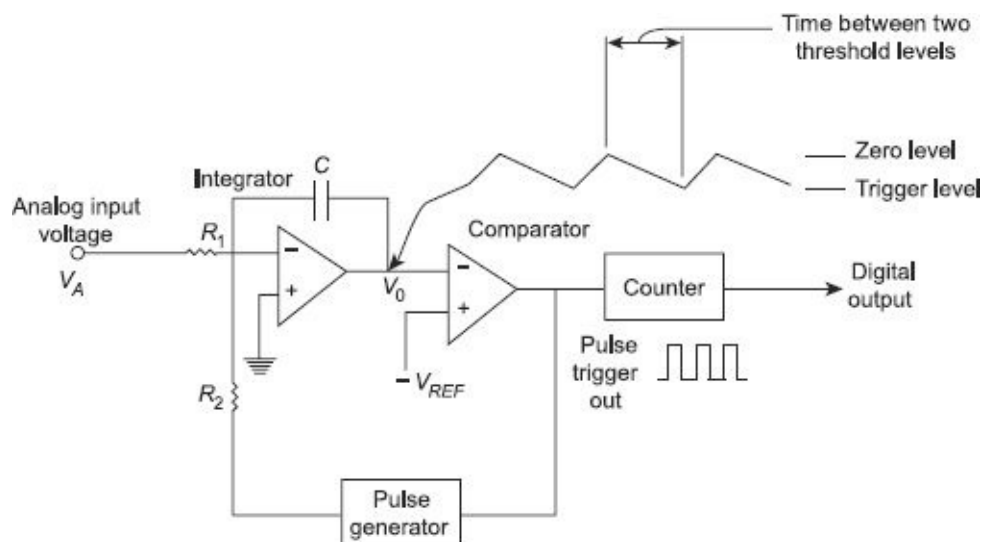

Figure 10.11 Block diagram of an integrating-type DVM

The above method provides measurement of the true average of the input signal over the ramp duration, and so provides high discrimination against noise present at the input.

However, the digitising rates are slow because of high integration durations. The accuracy of this method is comparable with the ramp type ADC, and is limited by the stability of the integrator time constant, and the stability and accuracy of the comparator.

This DVM has the drawback that it needs excellent characteristics in the linearity of the ramp. The ac noise and supply noise are averaged out.

10.6.4 Applications of DVMs

DVMs are often used in ‘data processing systems’ or ‘data logging systems’. In such systems, a number of analog input signals are scanned sequentially by an electronic system and then each signal is converted to an equivalent digital value by the A/D converter in the DVM.

The digital value is then transmitted to a pointer along with the information about the input line from which the signal has been derived. The whole data is then printed out.

In this way, a large number of input signals can be automatically scanned or processed and their values either printed or logged.

10.7

SIGNAL GENERATORS

A signal generator is numerous known as test signal generator, tone generator, arbitrary waveform generator, frequency generator, digital pattern generator, function generator, etc. It is an electronic device which produces repeating or non-repeating electronic signals (either analog or in digital patterns). These signals are utilised in testing, designing, troubleshooting and repairing electronic devices; apart from their artistic uses as well. Signal generators also modulate sinusoidal output signal with other signals. This feature is the main distinguisher between the signal generator and oscillator. When an unmodulated sinusoidal output is generated by the signal generators then they are said to be producing CW (continuous height wave) signal. When they produce modulated output signals then they can be in the form of square waves, externally applied sine waves, pulses, triangular waves, or more complex signals, as well as internally generated sine waves. Although Amplitude Modulation (AM) or Frequency Modulation (FM) can be used, yet amplitude modulation is generally employed. In [Figures 10.12\(a\)](#) and [10.12\(b\)](#), the principles of amplitude modulation and frequency modulation are shown respectively.

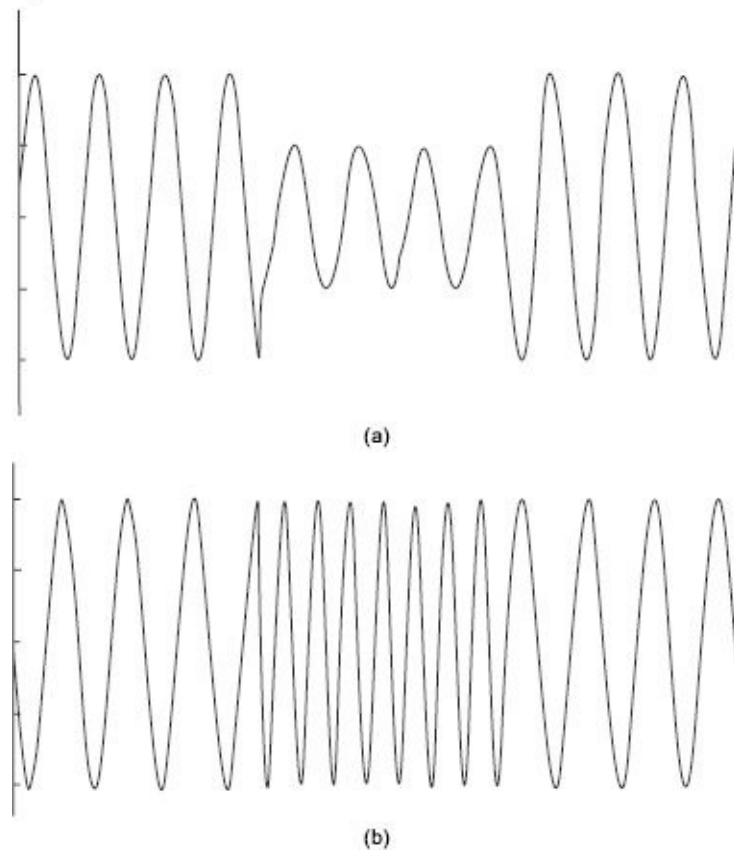

Figure 10.12 (a) Amplitude modulation (b) Frequency modulation

For providing appropriate signals for calibration and testing, signal generators are mainly employed. They are also used for troubleshooting of the amplifier circuits used in electronic and communications circuit amplifiers. Signal generators also measure the features of antennas and transmission lines.

Figure 10.13 illustrates the block diagram of a signal generator. A Radio Frequency (RF) oscillator is applied for producing a carrier waveform whose frequency can be attuned typically from about 100 kHz to 40 MHz. With the help of vernier dial setting and range selector switch, carrier wave frequencies can be varied and displayed. Frequency dividers are employed to determine the range. An oscillator's frequency stability is kept very high at all frequency ranges.

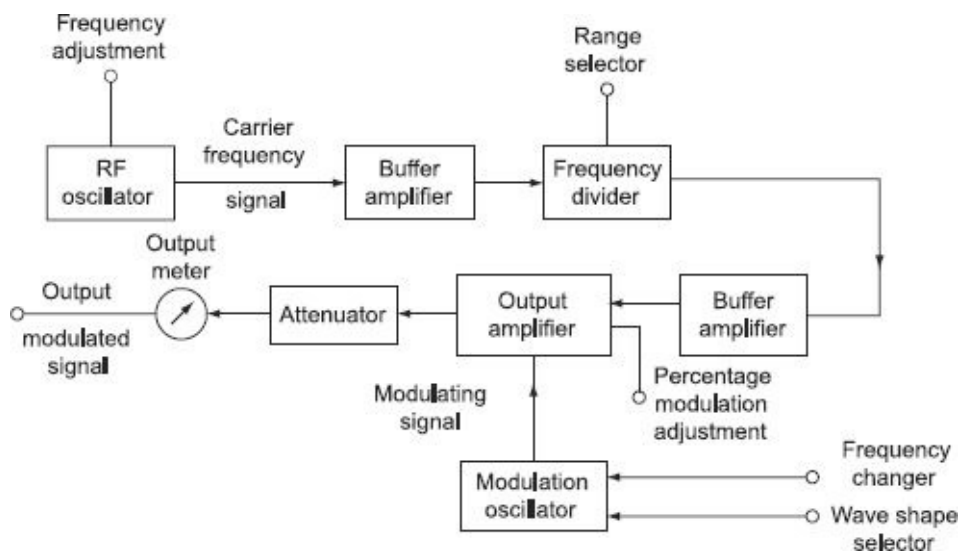

Figure 10.13 Block diagram of an AM signal generator

The following measures are taken in order to attain stable frequency output.

1. Regulated power supply is employed to reduce the change in supply voltage as it changes frequency of output voltage.
2. To separate the oscillator circuit from output circuit, buffer amplifiers are used. This is done so that any change in the circuit linked to the output does not affect the amplitude and frequency of the oscillator.
3. Temperature compensating devices are used to stable the temperature which causes change in oscillator frequency.
4. In place of an *LC* oscillator, a quartz crystal oscillator is employed to achieve high *Q*-factor, for instance, 20000.
5. When an audio frequency modulating signal is generated in another very stable oscillator, it is called the *modulation oscillator*. For changing the amplitude and the frequency of the produced signal, provision is made in the modulation oscillator.
6. Provision is also employed to get several types of waveforms such as the pulses, square, triangular oscillator. The modulation frequency and radio frequency signals are applied to a broadband amplifier, called the *output amplifier*. Modulation percentage is indicated and adjusted by the meter.
7. A control device can adjust modulation level up to 95%. The amplifier output is then sent to an attenuator and at last the signal reaches the output of the signal generator. An output meter reads or displays the final output signal.
8. An important specification of the signal generator performance is depending by the accuracy to which the frequency of the RF oscillator is tuned. Most laboratory-type signal generators are generally calibrated to be within 0.5–1.0% of the dial setting. For most measurements, this accuracy is sufficient. If greater accuracy is required then a crystal oscillator (frequency
9. Depending upon the different purposes and applications, various types of signal generators are available, however no device is suitable for all possible applications. Though traditional signal generators have embedded hardware units, with the advancement of multimedia-computers, audio software, tone generators signal generators have become more user-friendly and versatile.

EXERCISE

Objective-type Questions

1. Which one of the following statements is correct?
An electronic voltmeter is more reliable as compared to multimeter for measuring voltages across low impedance because
 - (a) its sensitivity is high
 - (b) it offers high input impedance
 - (c) it does not alter the measured voltage
 - (d) its sensitivity and input impedance are high and do not alter the measured value
2. VTVM can be used to measure
 - (a) dc voltage
 - (b) ac voltage of high frequency

- (c) dc voltage and ac voltage up to the order of 5 MHz frequency
 - (d) ac voltage of low frequency
3. Transistor voltmeter
- (a) cannot measure ac voltage
 - (b) cannot measure high frequency voltage
 - (c) cannot be designed to measure resistance as well as voltage
 - (d) can measure ac voltage
4. An electronic voltmeter provides more accurate readings in high-resistance circuits as compared to a nonelectronic voltmeter because of its
- (a) low meter resistance
 - (b) high Ω/V ratings
 - (c) high V/Ω ratings
 - (d) high resolution
5. The input impedance of a TVM as compared to that of a VTVM is
- (a) low
 - (b) high
 - (c) same
 - (d) not comparable
6. The power consumption of a dc voltmeter using a direct coupled amplifier when measuring a voltage of 0.5 volt and having an input impedance of $10\text{ M}\Omega$ is
- (a) a few nanowatts
 - (b) a few milliwatts
 - (c) a few microwatts
 - (d) a few watts
7. FETs are used in the amplifier to get
- (a) high output impedance
 - (b) high input impedance
 - (c) low output impedance
 - (d) low input impedance
8. A direct voltage is applied to a peak diode voltmeter whose scale is calibrated to read rms voltage of a sine wave. If the meter reading is 36 V_{rms} , the value of the applied direct voltage is
- (a) 51 volts
 - (b) 25 volts
 - (c) 36 volts
 - (d) 71 volts
9. A multimeter is used for the measurement of the following:
- 1. Both ac and dc voltage
 - 2. Both ac and dc current
 - 3. Resistance
 - 4. Frequency
 - 5. Power

Select the correct answer using the codes given:

- (a) 1, 2 and 4
 - (b) 1, 2 and 5
 - (c) 1, 3 and 5
 - (d) 1, 2 and 3
10. Modern electronic multimeters measure resistance by
- (a) using an electronic bridge compensator for nulling
 - (b) forcing a constant current and measuring the voltage across the unknown resistor
 - (c) using a bridge circuit
 - (d) applying a constant voltage and measuring the current through the unknown resistor
11. An n -bit A/D converter is required to convert an analog input in the range of 0–5 volt to an accuracy of 10 mV. The value of n should be
- (a) 8
 - (b) 9
 - (c) 10
 - (d) 16
12. Which of the following is not true for a digital frequency counter?
- (a) less costly
 - (b) high accuracy
 - (c) accepts inputs in the form of train of pulses
 - (d) wide range of frequency measurement
13. The resolution of a 12-bit analog to digital converter in per cent is
- (a) 0.04882
 - (b) 0.09760
 - (c) 0.01220
 - (d) 0.02441
14. A DVM measures
- (a) peak value
 - (b) rms value
 - (c) average value
 - (d) peak to peak value
15. Which of the following measurements can be made with the help of a frequency counter?
- 1. Fundamental frequency of input signal
 - 2. Frequency components of the input signal at least up to third harmonics
 - 3. Time interval between two pulses
 - 4. Pulse width

Select the correct answer using the codes given below:

- (a) 2 and 4
 - (b) 1 and 2
 - (c) 1, 2 and 3
 - (d) 1, 3 and 4
16. Accuracy of DVM is specified as
- (a) percentage of the full scale reading

- (b) percentage of the actual reading
- (c) number of least significant digit
- (d) all of these

Answers						
1. (d)	2. (c)	3. (d)	4. (b)	5. (a)	6. (b)	7. (b)
8. (a)	9. (d)	10. (b)	11. (b)	12. (a)	13. (d)	14. (c)
15. (d)	16. (a)					

Short-answer Questions

1. What are the merits of the digital system over analog system?
2. Briefly describe the performance characteristics of digital measurement.
3. Write down the comparison between analog and digital multimeters.
4. What is the basic principle of digital frequency meter?
5. How many types of digital voltmeters are there? Explain any one of them briefly.
6. What are the applications of the digital voltmeter?
7. How does an electronic voltmeter (EVM) measure ac signal?

Long-answer Questions

1. (a) What are the advantages of digital systems over analog?
(b) Explain the following terms as applied to digital measurement.
 - (i) Resolution
 - (ii) Sensitivity of digital meter
 - (iii) Accuracy specification of digital meters
2. (a) Explain the operating principle of a DVM using a suitable block diagram.
(b) With a neat sketch, describe the operating principle of dual slope integrating type of DVM.
3. Explain with the help of a functional block diagram, the principle of operation of a digital frequency meter.
4. With the help of a functional block diagram, describe the principle of operation of a digital multimeter.
5. What are the advantages of a digital voltmeter over analog type? What are its types? With a block diagram, explain the working of an integrating type. Compare its performance with other types.

The physical quantity under measurement makes its first contact in the time of measurement with a sensor. A *sensor* is a device that measures a physical quantity and converts it into a signal which can be read by an observer or by an instrument. For example, a mercury thermometer converts the measured temperature into expansion and contraction of a liquid which can be read on a calibrated glass tube. A thermocouple converts temperature to an output voltage which can be read by a voltmeter. For accuracy, all sensors need to be calibrated against known standards.

In everyday life, sensors are used everywhere such as touch sensitive mobile phones, laptop's touch pad, touch controller light, etc. People use so many applications of sensors in their everyday lifestyle that even they are not aware about it. Examples of such applications are in the field of medicine, machines, cars, aerospace, robotics and manufacturing plants. The sensitivity of the sensors is the change of sensor's output when the measured quantity changes. For example, the output increases 1 volt when the temperature in the thermocouple junction increases 1°C. The sensitivity of the thermocouple element is 1 volt/°C. To measure very small charges, the sensors should have very high sensitivity.

A *transducer* is a device, usually electrical, electronic, electro-mechanical, electromagnetic, photonic, or photovoltaic that converts one type of energy or physical attribute to another (generally electrical or mechanical) for various measurement purposes including measurement or information transfer (for example, pressure sensors).

The term transducer is commonly used in two senses; the sensor, used to detect a parameter in one form and report it in another (usually an electrical or digital signal), and the audio loudspeaker, which converts electrical voltage variations representing music or speech to mechanical cone vibration and hence vibrates air molecules creating sound.

Electrical transducers are defined as the transducers which convert one form of energy to electrical energy for measurement purposes. The quantities which cannot be measured directly, such as pressure, displacement, temperature, humidity, fluid flow, etc., are required to be sensed and changed into electrical signal first for easy measurement.

The advantages of electrical transducers are the following:

- Power requirement is very low for controlling the electrical or electronic system.

- An amplifier may be used for amplifying the electrical signal according to the requirement.
- Friction effect is minimised.
- Mass-inertia effect are also minimised, because in case of electrical or electronics signals the inertia effect is due to the mass of the electrons, which can be negligible.
- The output can be indicated and recorded remotely from the sensing element.

Basic Requirements of a Transducer

The main objective of a transducer is to react only for the measurement under specified limits for which it is designed. It is, therefore, necessary to know the relationship between the input and output quantities and it should be fixed. A transducer should have the following basic requirements:

1. Linearity

Its input vs output characteristics should be linear and it should produce these characteristics in balanced way.

2. Ruggedness

A transducer should be capable of withstanding overload and some safety arrangements must be provided with it for overload protection.

3. Repeatability

The device should reproduce the same output signal when the same input signal is applied again and again under unchanged environmental conditions, e.g., temperature, pressure, humidity, etc.

4. High Reliability and Stability

The transducer should give minimum error in measurement for temperature variations, vibrations and other various changes in surroundings.

5. High Output Signal Quality

The quality of output signal should be good, i.e., the ratio of the signal to the noise should be high and the amplitude of the output signal should be enough.

6. No Hysteresis

It should not give any hysteresis during measurement while input signal is varied from its low value to high value and vice versa.

7. Residual Reformation

There should not be any deformation on removal of input signal after long period of use.

11.3

LINEAR VARIABLE DIFFERENTIAL TRANSFORMER (LVDT)

The most widely used inductive transducer to translate the linear motion into electrical signals is the Linear Variable Differential Transformer (LVDT). The basic construction of

LVDT is shown in [Figure 11.1](#). The transformer consists of a single primary winding ‘P’ and two secondary windings S_1 and S_2 wound on a cylindrical former. A sinusoidal voltage of amplitude 3 to 15 Volt and frequency 50 to 20000 Hz is used to excite the primary. The two secondaries have equal number of turns and are identically placed on either side of the primary winding.

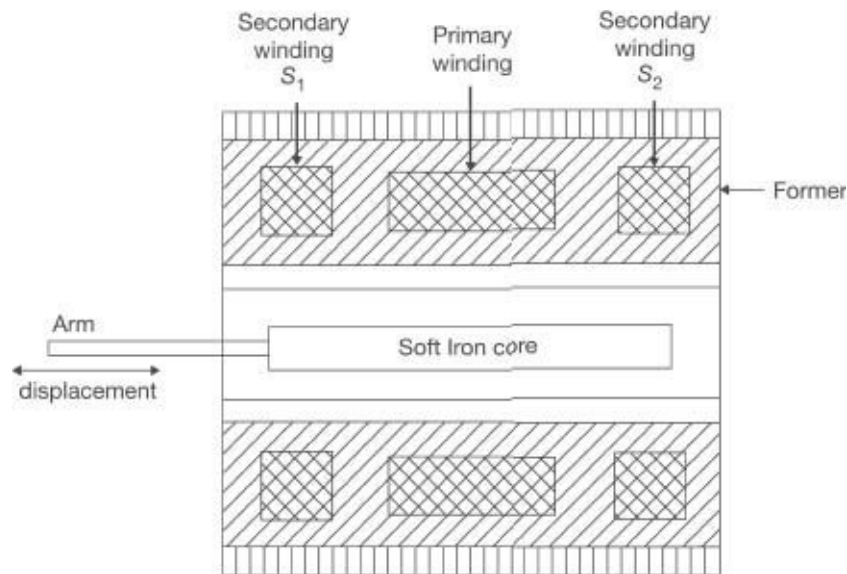

Figure 11.1 Linear Variable Differential Transformer (LVDT)

The primary winding is connected to an alternating current source. A movable soft-iron core is placed inside the former. The displacement to be measured is applied to the arm attached to the soft iron core. In practice the core is made of high permeability, nickel iron. This is slotted longitudinally to reduce eddy current losses. The assembly is placed in a stainless steel housing to provide electrostatic and electromagnetic shielding. The frequency of ac signal applied to primary winding may be between 50 Hz to 20 kHz.

Since the primary winding is excited by an alternating current source, it produces an alternating magnetic field which in turn induces alternating voltages in the two secondary windings.

The output voltage of secondary S_1 is E_{S1} and that of secondary S_2 is E_{S2} . In order to convert the outputs from S_1 and S_2 into a single voltage signal, the two secondary S_1 and S_2 are connected in series opposition as shown in [Figure 11. 2](#). Differential output voltage $E_0 = E_{S1} - E_{S2}$

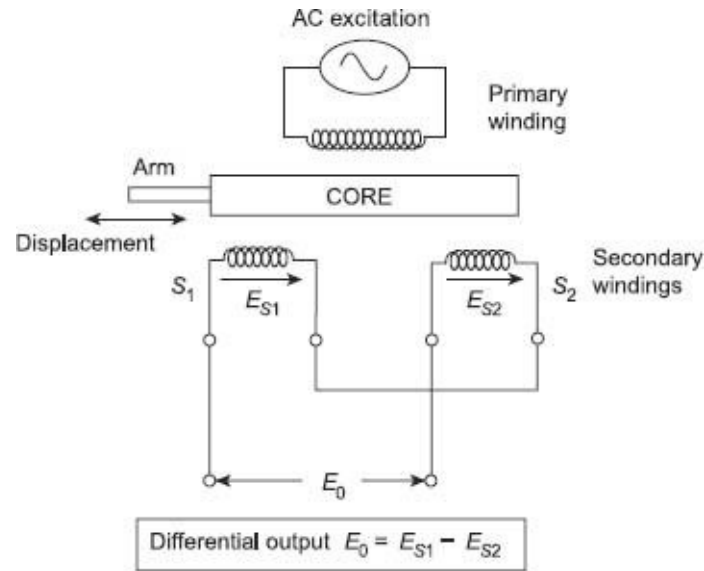

Figure 11.2 Connection of LVDT circuit

11.3.1 Operation

When the core is at its normal (NULL) position, the flux linking with both the secondary windings is equal and hence equal emfs are induced in them. Thus, at null position: $E_{S1} = E_{S2}$. Thus, the output voltage E_0 is zero at null position.

Now if the core is moved to the left of the null position, more flux links with S_1 and less with winding S_2 . Accordingly, output voltages E_{S1} is greater than E_{S2} . The magnitude of output voltage is thus, $E_0 = E_{S1} - E_{S2}$ and say it is in phase with primary voltage.

Similarly, when the core is moved to the right of the null position E_{S2} will be more than E_{S1} . Thus the output voltage is $E_0 = E_{S1} - E_{S2}$ and 180° out of phase with primary voltage.

The amount of voltage change in either secondary winding is proportional to the amount of movement of the core. Hence, we have an indication of amount of linear motion. By noticing whether output voltage is increased or decreased, we can determine the direction of motion.

11.3.2 Advantages and Disadvantages of LVDT

Advantages

- Linearity is good up to 5 mm of displacement.
- Output is rather high. Therefore, immediate amplification is not necessary.
- Output voltage is stepless and hence the resolution is very good.
- Sensitivity is high (about 40 V/mm).
- It does not load the measurand mechanically.
- It consumes low power and low hysteresis loss also.

Disadvantages

- LVDT has large threshold.
- It is affected by stray electromagnetic fields. Hence proper shielding of the device is necessary.
- The ac inputs generate noise.

- Its sensitivity is lower at higher temperature.
- Being a first-order instrument, its dynamic response is not instantaneous.

Example 11.1

The output of an LVDT is connected to a 5 V voltmeter through an amplifier of amplification factor 250. The voltmeter scales has 100 divisions and the scale can be read to 1/5th of a division. An output of 2 mV appears across the terminals of the LVDT when the core is displaced through a distance of 0.5 mm. Calculate (a) the sensitivity of the LVDT, (b) that of the whole set up, and (c) the resolution of the instrument in mm.

Solution

- (a) For a displacement of 0.5 mm, the output voltage is 2 mV.

Hence, the sensitivity of the LVDT is $\frac{2}{0.5} \text{ mV/mm} = 4 \text{ mV/mm}$

- (b) Due to the amplifier, this sensitivity is amplified 250 times in the set-up. Hence the sensitivity of the set-up is $4 \times 250 = 1 \text{ V/mm}$
- (c) The output of the voltmeter is 5 V with 100 divisions Each divisions corresponds to $\frac{5}{100} = 0.05 \text{ V}$ Since $\frac{1}{5}$ th of a division can be read, the minimum voltage that can be read is 0.01 V which corresponds to 0.01 mm. Hence, the resolution of the instrument is 0.01 mm.

11.4

STRAIN GAUGES

The strain gauge is an electrical transducer; it is used to measure mechanical surface tension. Strain gauge can detect and convert force or small mechanical displacement into electrical signals. On the application of force a metal conductor is stretched or compressed, its resistance changes owing to the fact both length and diameter of conductor change. Also, there is a change on the value of resistivity of the conductor when it is strained and this property of the metal is called piezoresistive effect. Therefore, resistance strain gauges are also known as piezoresistive gauges. The strain gauges are used for measurement of strain and associated stress in experimental stress analysis. Secondly, many other detectors and transducers, for example the load cell, torque meter, flow meter, accelerometer employ strain gauge as a secondary transducer.

Theory of Resistance Strain Gauges

The change in the value of resistance by the application of force can be explained by the normal dimensional changes of elastic material. If a positive strain occurs, its longitudinal dimension (x -direction) will increase while there will be a reduction in the lateral dimension (y -direction). The reverse happens for a negative strain. Since the resistance of a conductor is directly proportional to its length and inversely proportional to its cross-sectional area, the resistance changes. The resistivity of a conductor is also changed when strained. This property is known as piezoresistive effect.

Let us consider a strain gauge made of circular wire. The wire has the dimensions:

length L , area A , diameter D before being strained. The material of the wire has a resistivity ρ .

$$\therefore \text{resistance of unstrained gauge } R = \rho \frac{L}{A}$$

Let a tensile stress S be applied to the wire. This produces a positive strain causing the length to increase and the area to decrease as shown in [Figure 11.3](#). Let ΔL = Change in length, ΔA = Change in area, ΔD = Change in diameter and ΔR is the change in resistance.

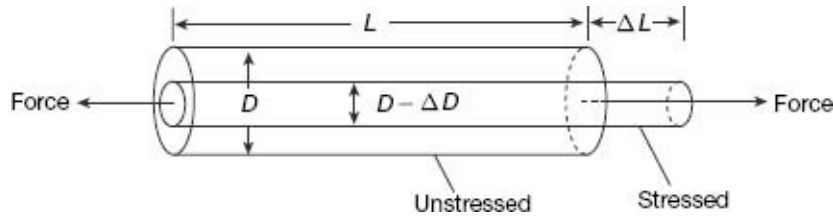

Figure 11.3 Change in dimensions of a strain-gauge element when subjected to a tensile force

In order to find how ΔR depends upon the material physical quantities, the expression for R is differentiated with respect to stress S . Thus,

$$\frac{dR}{dS} = \frac{\rho}{A} \frac{\partial L}{\partial S} - \frac{\rho L}{A^2} \frac{\partial A}{\partial S} + \frac{L}{A} \frac{\partial \rho}{\partial S} \quad (11.1)$$

Dividing [Eq. \(11.1\)](#) throughout by resistance $R = \rho \frac{L}{A}$, it becomes

$$\frac{1}{R} \frac{dR}{dS} = \frac{1}{L} \frac{\partial L}{\partial S} - \frac{1}{A} \frac{\partial A}{\partial S} + \frac{1}{\rho} \frac{\partial \rho}{\partial S} \quad (11.2)$$

It is clear from [Eq. \(11.2\)](#), that the per unit change in resistance is due to the following:

$$\text{Per unit change in length} = \frac{\Delta L}{L},$$

$$\text{Per unit change in area} = \frac{\Delta A}{A} \text{ and}$$

$$\text{Per unit change in resistivity} = \frac{\Delta \rho}{\rho}$$

$$\text{Area } A = \frac{\pi}{4} D^2 \therefore \frac{\partial A}{\partial S} = 2 \cdot \frac{\pi}{4} \cdot D \cdot \frac{\partial D}{\partial S}$$

$$\frac{1}{A} \frac{\partial A}{\partial S} = \frac{(\pi/2)D}{(\pi/4)D^2} \cdot \frac{\partial D}{\partial S} = \frac{2}{D} \frac{\partial D}{\partial S}$$

or,

putting this value of $\frac{1}{A} \frac{\partial A}{\partial S}$ in [Eq. \(11.2\)](#), it becomes

$$\frac{1}{R} \frac{\partial R}{\partial S} = \frac{1}{L} \frac{\partial L}{\partial S} - \frac{2}{D} \frac{\partial D}{\partial S} + \frac{1}{\rho} \frac{\partial \rho}{\partial S} \quad (11.3)$$

Now, Poisson's ratio

$$v = \frac{\text{Lateral strain}}{\text{Longitudinal strain}} = -\frac{\partial D/D}{\partial L/L}$$

$$\therefore \frac{\partial D}{D} = -v \times \frac{\partial L}{L}$$

$$\therefore \frac{1}{R} \frac{dR}{dS} = \frac{1}{L} \frac{\partial L}{\partial S} + v \frac{2}{L} \frac{\partial L}{\partial S} + \frac{1}{\rho} \frac{\partial \rho}{\partial S} \quad (11.4)$$

For small variations, the above relationship can be written as

$$\frac{\Delta R}{R} = \frac{\Delta L}{L} + 2v \frac{\Delta L}{L} + \frac{\Delta \rho}{\rho} \quad (11.5)$$

The gauge factor is defined as the ratio of per unit change in resistance to per unit change in length.

$$\therefore \text{gauge factor } G_f = \frac{\Delta R/R}{\Delta L/L} = 1 + 2v + \frac{\Delta \rho/\rho}{\epsilon} \quad (11.6)$$

where $\epsilon = \Delta L/L = \text{Strain}$

11.5

ELECTROMAGNETIC FLOW METER

Magnetic flow meters have been widely used in industry for many years. Unlike many other types of flow meters, they offer true non-invasive measurements. They are easy to install and use to the extent that existing pipes in a process can be turned into meters simply by adding external electrodes and suitable magnets. They can measure reverse flows and are insensitive to viscosity, density, and flow disturbances. Electromagnetic flow meters can rapidly respond to flow changes and they are linear devices for a wide range of measurements. In recent years, technological refinements have resulted in much more economical, accurate, and smaller instruments than the previous versions.

As in the case of many electric devices, the underlying principle of the electromagnetic flow meter is Faraday's law of electromagnetic induction. The induced voltages in an electromagnetic flow meter are linearly proportional to the mean velocity of liquids or to the volumetric flow rates. As is the case in many applications, if the pipe walls are made from nonconducting elements, then the induced voltage is independent of the properties of the fluid.

Figure 11.4 shows the schematic diagram of a Magnetic Meter (Magmeter), where V is the velocity of the liquid flow through the pipe, D is the internal diameter of the pipe, B is the flux density of the magnetic field and E_s is the induced voltage at the electrodes due to the flow of the liquid through the pipe placed in the magnetic field.

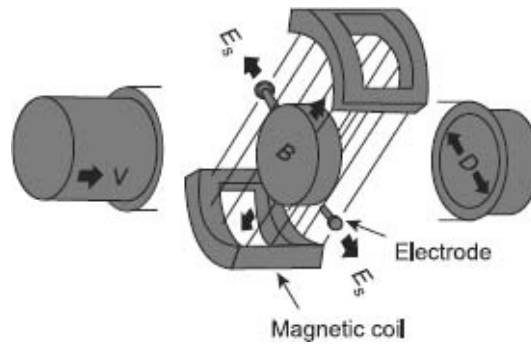

Figure 11.4 *The Magmeter and its components*

The accuracy of these meters can be 0.25% at the best and, in most applications, an accuracy of 1% is used. At worst, 5% accuracy is obtained in some difficult applications where impurities of liquids and the contact resistances of the electrodes are inferior as in the case of low-purity sodium liquid solutions.

11.5.1 Faraday's Law of Induction

This law states that if a conductor of length l (m) is moving with a velocity v (m/s), perpendicular to a magnetic field of flux density B (Tesla) then the induced voltage across the ends of conductor can be expressed by

$$e = Blv \quad (11.7)$$

The principle of application of Faraday's law to an electromagnetic flow meter is given in [Figure 11.5](#). The magnetic field, the direction of the movement of the conductor, and the induced emf are all perpendicular to each other.

[Figure 11.6](#) illustrates a simplified electromagnetic flow meter in greater detail. Externally located electromagnets create a homogeneous magnetic field (B) passing through the pipe and the liquid inside it. When a conducting flowing liquid cuts through the magnetic field, a voltage is generated along the liquid path between two electrodes positioned on the opposite sides of the pipe.

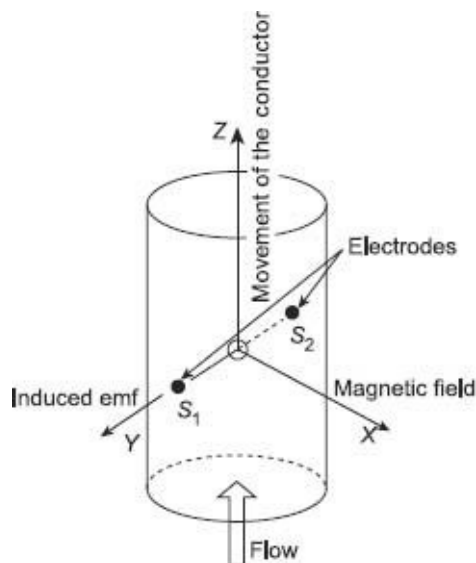

Figure 11.5 *Operational principle of electromagnetic flow meters*

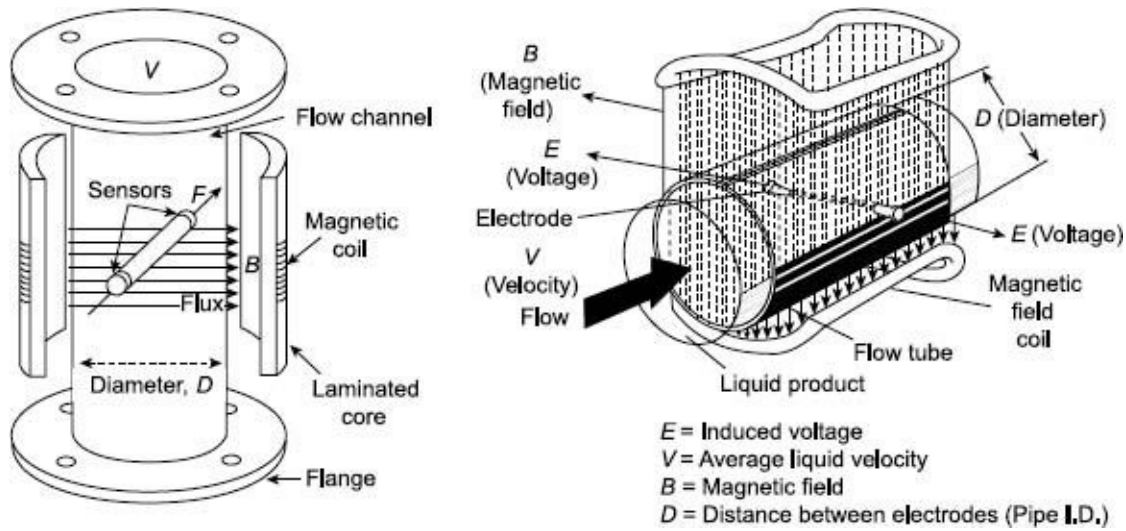

Figure 11.6 Construction of practical flow meters

In the case of electromagnetic flow meters, the conductor is the liquid flowing through the pipe, and the length of the conductor is the distance between the two electrodes, which is equal to the tube diameter (D). The velocity of the conductor is proportional to the mean flow velocity (v) of the liquid. Hence, the induced voltage becomes

$$e = BDv \quad (11.8)$$

If the magnetic field is constant and the diameter of the pipe is fixed, the magnitude of the induced voltage will only be proportional to the velocity of the liquid. If the ends of the conductor, in this case the sensors, are connected to an external circuit, the induced voltage causes a current, i to flow, which can be processed suitably as a measure of the flow rate. The resistance of the moving conductor can be represented by R to give the terminal voltage as $v_T = e - iR$.

Electromagnetic flow meters are often calibrated to determine the volumetric flow of the liquid. The volume of liquid flow, Q can be related to the average fluid velocity as

$$Q = Av \quad (11.9)$$

Writing the area, A of the pipe as

$$A = \frac{\pi D^2}{4} \quad (11.10)$$

gives the induced voltage as a function of the flow rate.

$$e = \frac{4BQ}{\pi D} \quad (11.11)$$

Equation (11.11) indicates that in a carefully designed flow meter, if all other parameters are kept constant, then the induced voltage is linearly proportional to the liquid flow only.

Based on Faraday's law of induction, there are many different types of electromagnetic flow meters available, such as ac, dc, and permanent magnets. The two most commonly used ones are the ac and dc types. This section concentrates mainly on ac and dc type flow meters.

Although the induced voltage is directly proportional to the mean value of the liquid flow, the main difficulty in the use of electromagnetic flow meters is that the amplitude of the induced voltage is small relative to extraneous voltages and noise. Noise sources

include

- Stray voltage in the process liquid
- Capacitive coupling between signal and power circuits
- Capacitive coupling in connection leads
- Electromechanical emf induced in the electrodes and the process fluid
- Inductive coupling of the magnets within the flow meter

Advantages of Electromagnetic Flow Meter

- The electromagnetic flow meter can measure flow in pipes of any size provided a powerful magnetic field can be produced.
- The output (voltage) is linearly proportional to the input (flow).
- The major advantage of electromagnetic flow meter is that there is no obstacle to the flow path which may reduce the pressure.
- The output is not affected by changes in characteristics of liquid such as viscosity, pressure and temperature.

Limitations

- The operating cost is very high in an electromagnetic flow meter, particularly if heavy slurries (solid particle in water) are handled.
- The conductivity of the liquid being metered should not be less than $10 \mu\Omega/\text{m}$. It will be found that most aqueous solutions are adequately conductive while a majority of hydrocarbon solutions are not sufficiently conductive.

11.5.2 Comparison of dc and ac Excitation of Electromagnetic Flow Meter

The magnetic field used in electromagnetic flow meter can either be ac or dc giving rise to ac or a dc output signal respectively. The dc excitation is used in few applications due to the following limitations of the dc excitation.

When dc excitation is used for materials of very low conductivity and flowing at slow speeds, the output emf is too small to be easily read off. The dc amplifiers used in this purposes are also have some inherent problems especially at low level.

Many hydrocarbon or aqueous solutions exhibit polarisation effects when the excitation is dc. The positive ions migrate to the negative electrode and disassociate, forming an insulating pocket of gaseous hydrogen, there is no such phenomena when ac is used.

The dc field may distort the fluid velocity profile by Magneto Hydro Dynamic (MHD) action. An ac field of normal frequency (50 Hz) has little effect on velocity profile because fluid inertia and friction forces at 50 Hz and sufficient to prevent any large fluid motion.

Since the output of electromagnetic flow meters is quite small (a few mV), interfering voltage inputs due to thermocouple type of effects and galvanic action of dissimilar metals used in meter construction may be of the same order as the signal. Since the spurious interfering inputs are generally drifts of very low frequency, the 50 Hz system can use high pass filters to eliminate them.

While ac system predominates, dc types of systems have been used for flow measurements of liquid metals like mercury. Here, no polarisation problem exists. Also, an insulating pipe or a nonmetallic pipe is not needed since the conductivity of the liquid metal is very good relative to an ordinary metal pipe. This means that the metal pipe is not

very effective as a short circuit for the voltage induced in the flowing liquid metal. When metallic pipes are used as with dc excitation no special electrodes are necessary. The output voltage is tapped off the metal pipe itself at the points of maximum potential difference.

11.6

TEMPERATURE TRANSDUCERS

Application of heat or its withdrawal from a body produces various primary effects on this body such as

- Change in its physical or chemical state such as phase transition
- Change in its physical dimensions
- Variations in its electrical properties
- Generation of an emf at the junction of two dissimilar metals
- Change in the intensity of the emitted radiation

Any of these effects can be employed to measure the temperature of a body, though the first one is generally used for standardisation of temperature sensors rather than for direct measurement of temperature.

11.6.1 Resistance Thermometers

Resistance temperature detectors, or resistance thermometers, employ a sensitive element of extremely pure platinum, copper or nickel wire that provides a definite resistance value at each temperature within its range. The relationship between temperature and resistance of conductors in the temperature range near 0°C can be calculated from the equation

$$R_t = R_{ref}(1 + \alpha\Delta t) \quad (11.12)$$

where R_t = resistance of the conductor at temperature t (°C)

R_{ref} = resistance at the reference temperature, usually 0°C

α = temperature coefficient of resistance

Δt = difference between operating and reference temperature

Almost all metallic conductors have a positive temperature coefficient of resistance so that their resistance increases with an increase in temperature. Some materials, such as carbon and germanium, have a negative temperature coefficient of resistance that signifies that the resistance decreases with an increase in temperature. A high value of α is desirable in a temperature sensing element so that a substantial change in resistance occurs for a relatively small change in temperature. This change in resistance (ΔR) can be measured with a Wheatstone bridge, which may be calibrated to indicate the temperature that caused the resistance change rather than the resistance change itself.

Figure 11.7 indicates the variation of resistance with temperature for several commonly used materials. The graph shows that the resistance of platinum and copper increases almost linearly with increasing temperature, while the characteristic for nickel is decidedly nonlinear.

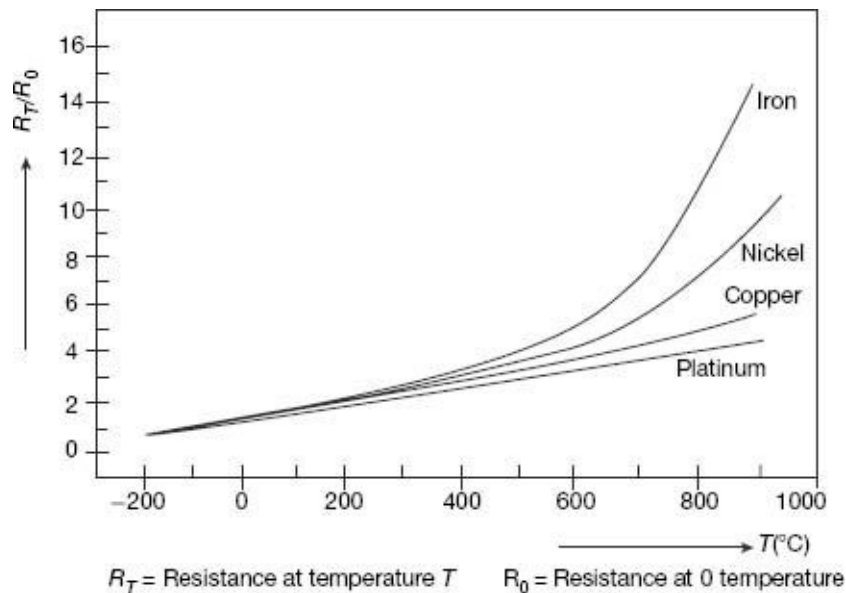

Figure 11.7 Relative resistance (R_T/R_0) versus temperature for some pure metals

The sensing element of a resistance thermometer is selected according to the intended application. Table 11.1 summarises the characteristics of the three most commonly used resistance materials. Platinum wire is used for most laboratory work and for industrial measurements of high accuracy. Nickel wire and copper wire are less expensive and easier to manufacture than platinum wire elements, and they are often used in low-range industrial applications.

Table 11.1 Resistance thermometer elements

Type	Temperature range	Accuracy	Advantages	Disadvantages
Platinum	-3000°F to +15000°F	±0.1°F	Low cost, high stability, wide operating range	Relatively slow response time (15s), not as linear as copper thermometers.
Copper	-3250°F to +2500°F	±0.50°F	High linearity, high accuracy in ambient temperature range, high stability	Limited temperature range (to 2500°F)
Nickel	-320°F to +1500°F	±0.50°F	Longer life, high sensitivity, high temperature coefficient	More nonlinear than copper, limited temperature range (to 1500°F)

Resistance thermometers are generally of the probe type for immersion in the medium whose temperature is to be measured or controlled. A typical sensing element for a probe-type thermometer is constructed by coating a small platinum or silver tube with ceramic material, winding the resistance wire over the coated tube, and coating the finished winding again with ceramic. This small assembly is then fired at high temperature to assure annealing of the winding and then it is placed at the tip of the probe. The probe is protected by a sheath to produce the complete sensing elements as shown in Figure 11.8.



Figure 11.8 Resistance thermometer in protecting cover

Practically, all resistance thermometers for industrial applications are mounted in a tube or well to provide protection against mechanical damage and to guard against contamination and eventual failure. Protecting tubes are used at atmospheric pressure;

when they are equipped inside a pipe thread bushing, they may be exposed to low or medium pressures. Metal tubes offer adequate protection to the sensing element at temperatures up to 100°F, although they may become slightly porous at temperatures above 1500°F and then fail to protect against contamination.

Protecting covers are designed for use in liquid or gases at high pressure such as in pipe lines, steam power plants, pressure tanks, pumping stations, etc. The use of a protecting cover becomes imperative at pressures above three times of atmospheric pressure. Protective wells are drilled from solid bar stock, usually carbon steel or stainless steel, and the sensing element is mounted inside. A waterproof junction box with provision for conduit coupling is attached to the top of the tube or well.

A typical bridge circuit with resistance thermometer R_t in the unknown position is shown in Figure 11.9. The function switch connects three different resistors in the circuit. R_{Ref} is a fixed resistor whose resistance is equal to that of the thermometer element at the reference temperature (say, 0°C). With the function switch in the 'REFERENCE' position, the zero adjust resistor is varied until the bridge indicator reads zero. R_{fs} is another fixed resistor whose resistance equals that of the thermometer element for full-scale reading of the current indicator. With the function switch in the 'FULL SCALE' position, the full scale adjust resistor is varied until the indicator reads the full scale. The function switch is then set to the 'MEASUREMENT' position, connecting the resistance thermometer R_t in the circuit. When the resistance temperature characteristic of the thermometer element is linear, the galvanometer indication can be interpolated linearly between the set of values of reference temperature and full scale temperature.

The Wheatstone bridge has certain disadvantages when it is used to measure the resistance variations of the resistance thermometer. These are the effects of contact resistances of connections to the bridge terminals, heating of the elements by the unbalance current and heating of the wires connecting the thermometer to the bridge. Slight modifications of the Wheatstone bridge, such as the double slide wire bridge eliminates most of these problems. Despite these measurement difficulties, the resistance thermometer method is so accurate that it is one of the standard methods of temperature measurement within the range -150° to 650°C .

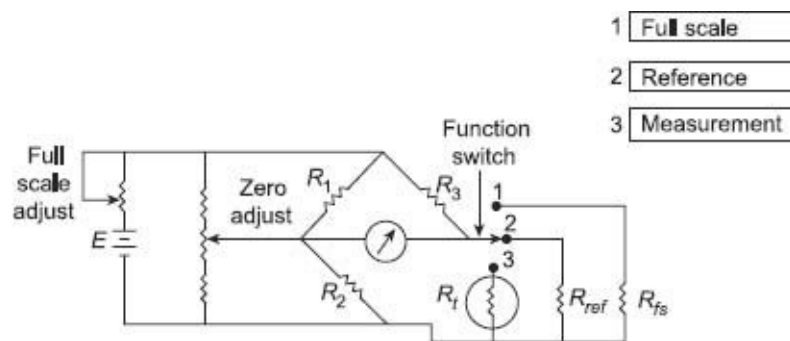

Figure 11.9 Wheatstone bridge circuit with a resistance thermometer as one of the bridge elements

11.6.2 Thermocouple

Thomas Seebeck discovered in 1821 that when two dissimilar metals were in contact, a voltage was generated where the voltage was a function of temperature. The device, consisting of two dissimilar metals joined together, is called a *thermocouple* and the

voltage is called the *Seebeck voltage*, according to the name of the discoverer.

As an example, joining copper and constantan produces a voltage on the order of a few tens of millivolts (Figure 11.10) with the positive potential at the copper side. An increase in temperature causes an increase in voltage.

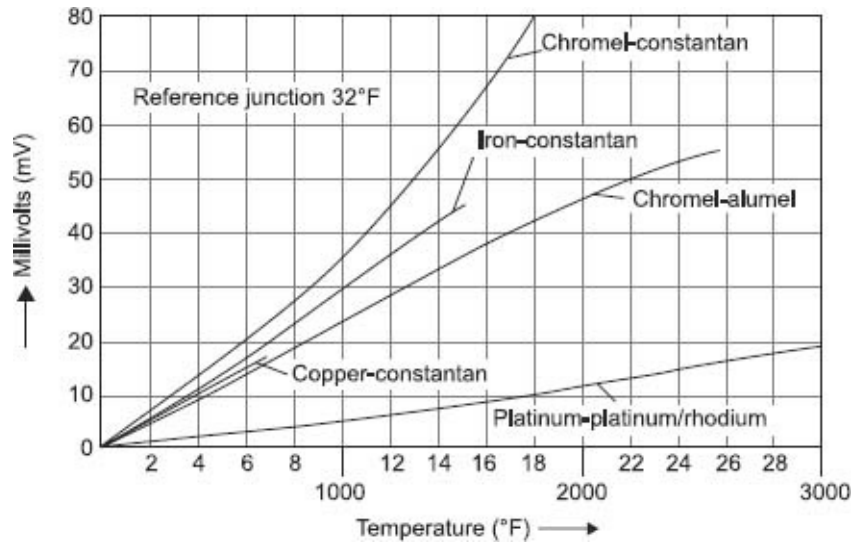

Figure 11.10 Thermocouple output voltage as a function of temperature for various thermocouple materials

There are several methods of joining the two dissimilar metals. One is to weld the wires together. This produces a brittle joint, and if not protected from stresses, this type of thermocouple can fracture and break apart. During the welding process, gases from the welding can diffuse into the metal and cause a change in the characteristic of the thermocouple. Another method of joining the two dissimilar metals is to solder the wires together. This has the disadvantage of introducing a third dissimilar metal. Fortunately, if both sides of the thermocouple are at the same temperature, the Seebeck voltage due to thermocouple action between the two metals of the thermocouple and the solder will have equal and opposite voltages and the effect will cancel. A more significant disadvantage is that in many cases the temperatures to be measured are higher than the melting point of the solder and the thermocouple will come apart.

It would appear to be a simple matter to measure the Seebeck voltage and create an electronic thermometer. To do this, wires could be connected as shown in Figure 11.11 to make the measurement. This connection of the wires causes a problem of measurement, as shown in Figure 11.12.

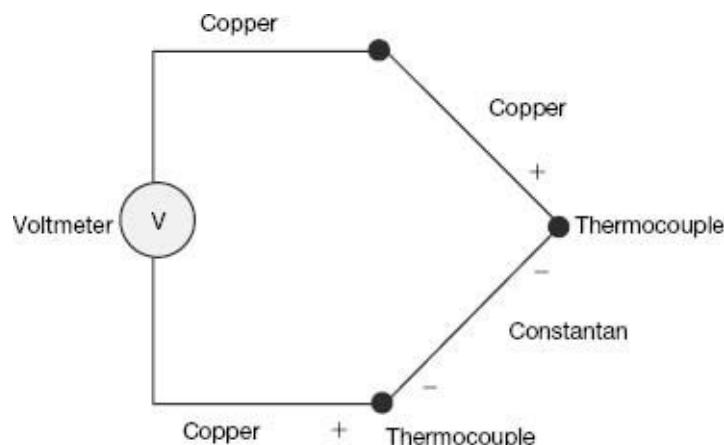

Figure 11.11 Effects of additional parasitic thermocouple

Assume that the meter uses copper wires as shown. In this case, where the two copper wires come in contact there is no problem, but where the copper comes in contact with another metal, such as the constantan thermocouple wire, the two dissimilar metals create another thermocouple, which generates its own Seebeck voltage. For this example, copper interconnecting wires were used and the thermocouple was copper and constantan. The composition of the wires is immaterial, as any combination will produce these parasitic thermocouples with the problems of additional Seebeck voltages. It is an inescapable fact that there will be at least two thermocouple junctions in the system. To contend with this, it is necessary that the temperature of one of the junctions be known and constant. Therefore, there is a fixed offset voltage in the measuring system. In early times, it is mandatory to place this junction in a mixture of ice and water, thus stabilising the temperature to 0°C as shown in [Figure 11.13](#). In modern-age electronic reference junction is used and it is called the reference or cold junction because this junction was traditionally placed in the ice bath.

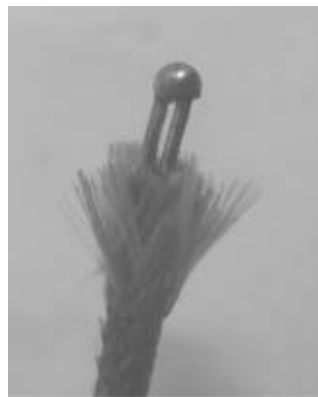

Figure 11.12 Connection of wires

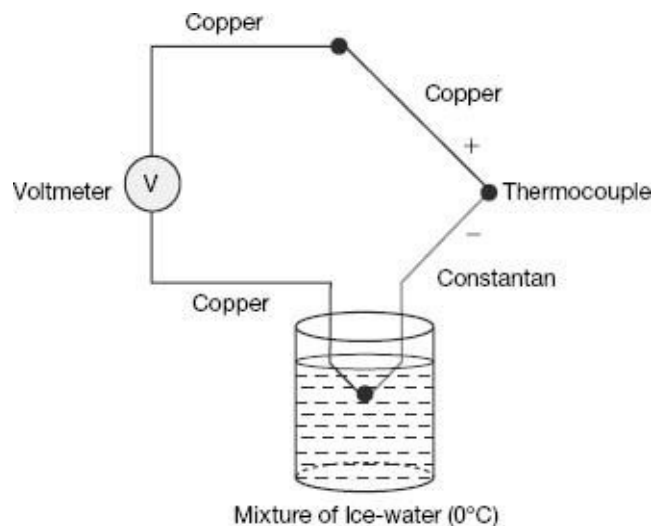

Figure 11.13 Application of a reference junction

The classic method of measuring thermocouple voltages was the use of a potentiometer. This was a mechanical device and is no longer used. Completely electronic devices are used to measure thermocouple voltages and to convert from the Seebeck voltage to temperature, and to compensate for the reference junction.

11.6.3 Errors occurring During the Measurement using Thermocouple

1. Open Junction

There are many sources of an open junction. Usually, the error introduced by an open junction is of such an extreme magnitude that an open junction is easily spotted. By simply measuring the resistance of the thermocouple, the open junction is easily identified.

2. Insulation Degradation

The thermocouple is often used at very high temperatures. In some cases, the insulation can break down and causes a significant leakage resistance which will cause an error in the measurement of the Seebeck voltage. In addition, chemicals in the insulation can diffuse into the thermocouple wire and cause decalibration.

3. Thermal Conduction

The thermocouple wire will shunt heat energy away from the source to be measured. For small temperature to be measured, small diameter thermocouple wire could be used. However, the small diameter wire is more susceptible to the effects. If a reasonable compromise between the degrading effects of small thermocouple wire and the loss of thermal energy and the resultant temperature error cannot be found, thermocouple extension wire can be used. This allows the thermocouple to be made of small diameter wire, while the extension wire covers majority of the connecting distance.

4. Galvanic Action

Chemicals coming in contact with the thermocouple wire can cause a galvanic action. This resultant voltage can be as much as 100 times the Seebeck voltage, causing extreme errors.

5. Decalibration

This error is a potentially serious fault, as it can cause slight error that may escape detection. Decalibration is due to altering the characteristics of the thermocouple wire, thus changing the Seebeck voltage. This can be caused due to subjecting the wire to excessively high temperatures, diffusion of particles from the atmosphere into the wire, or by cold working the wire.

11.6.4 Thermistors

Thermistors (construction of thermal resistor) are semiconductors which behave as resistors with a high negative temperature coefficient of resistance.

Manganese, nickel or cobalt oxides are milled, mixed in proper proportion with binders, passes into desired shapes and then sintered to form thermistors in the form of beads, rods or discs. Sometimes, a glass envelope is provided to protect a thermistor form contaminations.

The resistance R_T of a thermistor at temperature T (Kelvin) can be written as

$$R_T = R_0 \exp \left[\beta \left(\frac{1}{T} - \frac{1}{T_0} \right) \right] \quad (11.13)$$

where R_T and R_0 are the resistances in ohms of the thermistor at absolute temperatures T

and $T_0\beta$ is a thermistor constant ranging from 3500 K to 5000 K. The reference temperature T_0 is usually taken as 298 K or 25°C.

Now the temperature coefficient of the resistance

$$\alpha = \frac{1}{R_T} \frac{dR_T}{dT} = -\frac{\beta}{T^2} \text{ [from equation (11.13)]}$$

At $T = 298$ K, the value of α is

$$\alpha = -\frac{4000}{298^2} = -0.045 \text{ } \Omega / ^\circ\text{C} \frac{\beta}{T^2} \text{ [assume } \beta = 4000 \text{ K]} \quad (11.14)$$

This is evidently a rather high temperature coefficient because for a platinum resistance thermometer the corresponding figure is 0.0035/°C.

The plot of resistivity (ρ) versus temperature (Figure 11.14) will also demonstrate this comparison.

Equation (11.13) can be rearranged to the form

$$\frac{1}{T} = \left(\frac{1}{T_0} - \frac{1}{\beta} \ln R_0 \right) + \frac{1}{\beta} \ln R_T \quad (11.15)$$

$$\frac{1}{T} = A + B \ln R_T \quad (11.16)$$

where A and B are constants. Eq. (11.16) may alternatively be used to find temperatures by evaluating A and B from two pairs of known values of R_T and T .

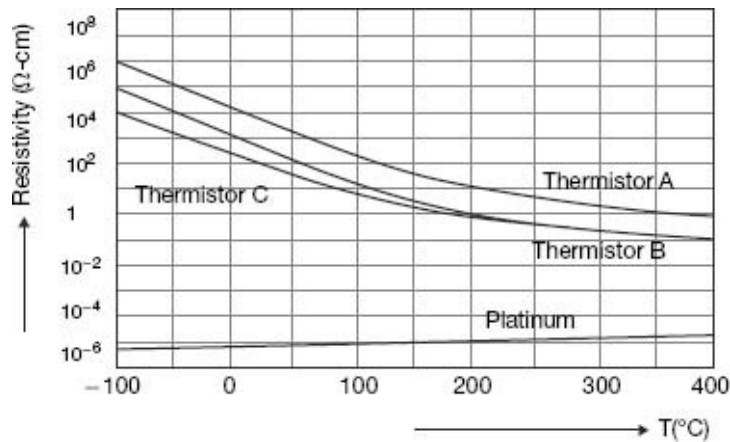

Figure 11.14 Comparison of resistivity of platinum with that of thermistors

Thermistors are very popular as temperature transducers because (i) they are compact, rugged, inexpensive, (ii) their calibration is stable, (iii) they have a small response time, (iv) they are amenable to remote measurements, and above all, (v) their accuracy is high.

Example 11.2

For a certain thermistor $\beta = 3100$ K and its resistance at 20°C is known to be 1050 Ω . The thermistor is used for temperature measurement and the resistance measured is 2300 Ω . Find the measured temperature if the temperature-resistance characteristics of the thermistor is given by

$$R = R_0 \exp \left[\beta \left(\frac{1}{T} - \frac{1}{T_0} \right) \right]$$

where T is in Kelvin.

Solution Here, $R_0 = 1050 \Omega$, $T_0 = 293 \text{ K}$. hence from Eq. (11.15), we get

$$\frac{1}{T} = \frac{1}{293} - \frac{\ln 1050}{3100} + \frac{\ln 2300}{3100} = 3.6659 \times 10^{-3}$$

which gives $T = 272.8 \text{ K} \cong 0^\circ\text{C}$

Example 11.3

The resistance of a thermistor is 800Ω at 50°C and $4 \text{ k}\Omega$ at the ice-point. Calculate the characteristic constants (A , B) for the thermistor and the variations in resistance between 30°C and 100°C .

Solution Form Eq. (11.16), we get the following conditions:

$$A + B \ln 800 = \frac{1}{323}$$

$$A + B \ln 4000 = \frac{1}{273}$$

which gives $A = 7.4084 \times 10^{-4}$ and $B = 3.5232 \times 10^{-4}$.

The variation in resistance can be calculated from the relation

$$R_T = \exp \left[\left(\frac{1}{t+273} - A \right) \div B \right]$$

As

$t(^\circ\text{C})$	30	40	50	60	70	80	90	100
$R_t(\Omega)$	1428.9	1059.3	800	614.5	479.3	379.1	303.8	246.3

11.7

PRESSURE MEASUREMENT

The pressure, or force, measurement can be done by converting the applied pressure or force into a displacement by elastic elements which acts as a primary transducer. The displacement of the elastic element which is a function of the applied force may be measured by the transducer which acts as a secondary transducer. The output of the secondary transducer is a function of the displacement, which in turn is a function of pressure or force which is the measurand. Some mechanical methods are used to convert the applied pressure of force into displacement. These mechanical devices are called *force summing devices*.

The most commonly used summing devices are

1. Flat or corrugated diaphragms
2. Pivot torque
3. Straight tube
4. Single or double mass cantilever suspension
5. Circular or twisted Bourdon tube
6. Bellows

Among these, pressure transducers generally use flat or corrugated diaphragms, bellows, circular or twisted Bourdon tubes and straight tubes. Single or double mass cantilever suspension and pivot torque types are found in accelerometer and velocity transducers. Different kinds of force summing devices are shown in the [Figure 11.15](#).

Secondary Transducers

The displacement produced by the action of the force summing devices is converted into a change of some electrical parameter. The various transducers used for this purpose are of the following types:

1. Resistive
2. Inductive
3. Differential transformer
4. Capacitive
5. Photo-electric
6. Piezo-electric
7. Ionization
8. Oscillation.

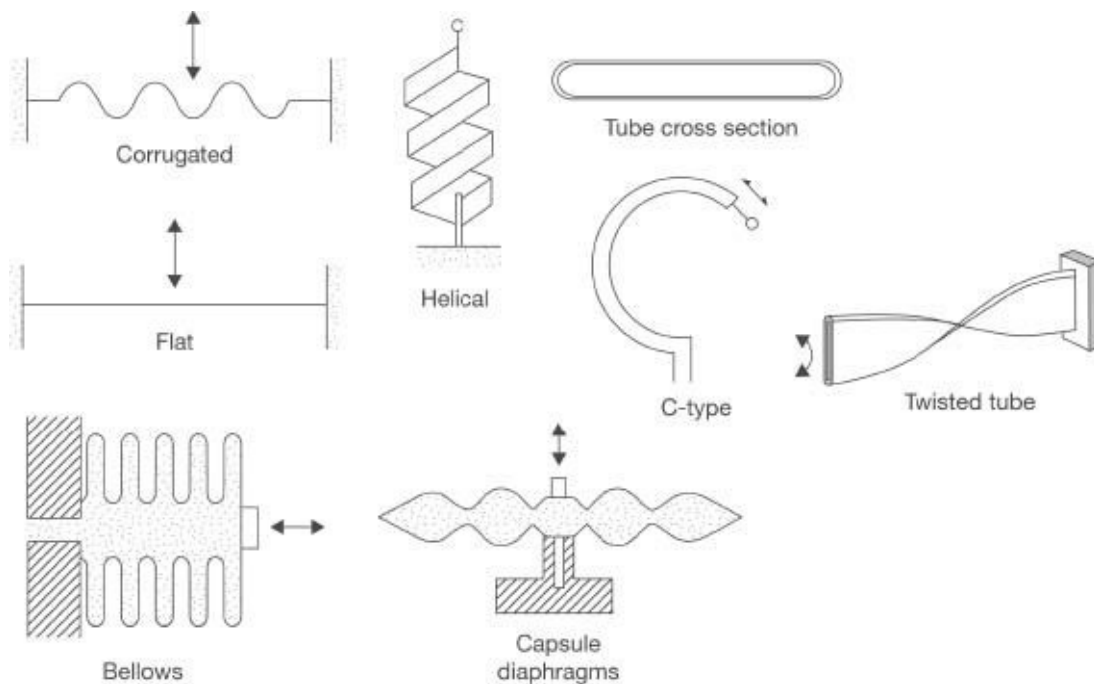

Figure 11.15 Different types of summing devices

11.7.1 Resistive Transducers

The electrical strain gauges attached to a diaphragm may be used for measurement of pressure. The diagram is shown in [Figure 11.16](#). The output of these strain gauges is a function of the applied strain, which in turn, is a function of the diaphragm deflection and the differential pressure. The deflection generally follows a linear variation with differential pressure $P = P_2 - P_1$ (when the deflection is less than 1/3 of the diaphragm thickness). One of the disadvantages of this method is small physical area is required for mounting the strain gauges. Change in resistance of strain gauges on account of application of pressure is calibrated in terms of the differential pressure. Gauges of this type are made in sizes having a lower range of 100 kN/m² to 3 MN/m² to an upper range

of 100 kN/m² to 100 MN/m².

11.7.2 Inductive Transducers

This type of transducers has been successfully used as secondary transducers along with a diaphragm for measurement of pressure. Figure 11.17 shows an arrangement which uses two coils; an upper and a lower coil which form the two arms of an ac bridge. The coils have equal number of turns. The other two arms of the bridge are formed by two equal resistances each of value R . The diaphragm is symmetrically placed with respect to the coils and so when $P_1 = P_2$, The reluctances of the path of magnetic flux for both the coils are equal and hence the inductances of the coils are equal.

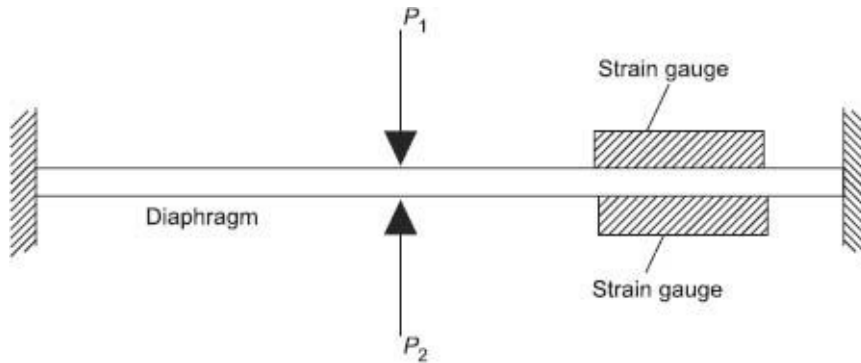

Figure 11.16 Differential pressure measurement with diaphragm and strain gauges

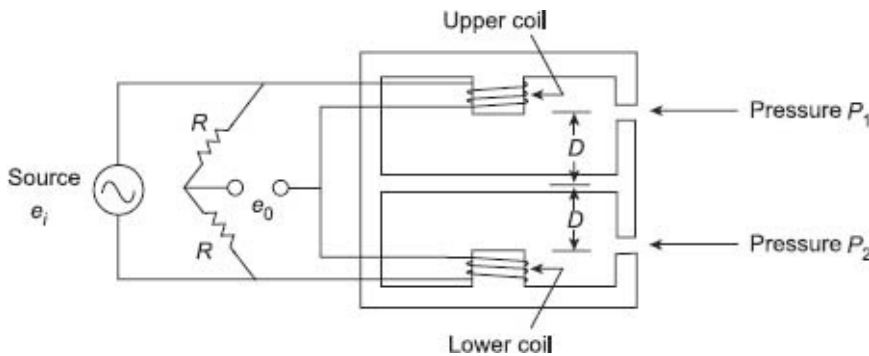

Figure 11.17 Pressure measurement with diaphragm and inductive transducer

Now, I initial self-inductance = N^2/R_0 , where Number of turns, and R_0 = Initial reluctance of the flux path. Under this condition the bridge is balanced and the output, E_0 , of the bridge is zero. Now for any particular moment P_2 is greater than P_1 and therefore the differential pressure $P = P_2 - P_1$, deflects the diaphragm upwards through a distance d . for small displacement of diaphragms, the reluctance of the flux path of the upper coil is $R_1 = R_0 + K (D - d)$ and that of the lower coil is $R_2 = R_0 + K (D + d)$. Where K is a constant, D is the initial distance of the diaphragm from the coils and d is the displacement of the diaphragms due to force. Hence, the inductance of the upper coil

$$L_1 = \frac{N^2}{R_1} = \frac{N^2}{[R_0 + K(D - d)]} \tag{11.17}$$

and that of the lower coil is

$$L_2 = \frac{N^2}{R_2} = \frac{N^2}{[R_0 + K(D + d)]} \tag{11.18}$$

The bridge becomes unbalanced and the value of output voltage is given by

$$e_0 = \left[\frac{1}{2} - \frac{L_2}{L_1 + L_2} \right] \times e_i = \left[\frac{1}{2} - \frac{N^2 / [R_0 + K(D+d)]}{N^2 / [R_0 + K(D-d)] + N^2 / [R_0 + K(D+d)]} \right] \times e_i \approx \frac{Kd \times e_i}{2(R_0 + KD)} \quad (11.19)$$

Since K , R_0 , D and e_i are constant, the output voltage is directly proportional to displacement d , of the diaphragm. Displacement d , is directly proportional to differential pressure $P = P_2 - P_1$. Hence the output voltage e_0 may be calibrated in terms of the differential pressure P .

If the value of the deflection d is small then there exists a linear relationship between output voltage e_0 and the differential pressure. It is possible to determine whether $P_2 > P_1$ or $P_1 > P_2$ with reference to the phase of the output voltage, e_0 , with respect to source voltage e_i .

11.7.3 Differential Transformers

The linear variable differential transformers (LVDT) is used as a secondary transducer for measuring the pressure with bellows or bourdon tube acting as a primary transducers, i.e., as a force summing device. The pressure is converted into displacement which is sensed by the LVDT and transformed into a voltage. The two arrangements are shown in [Figure 11.18](#) and [11.19](#).

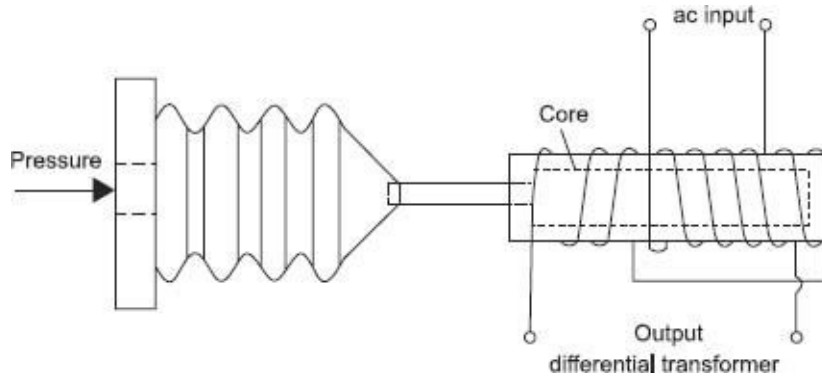

Figure 11.18 Pressure measurement with bellows and LVDT

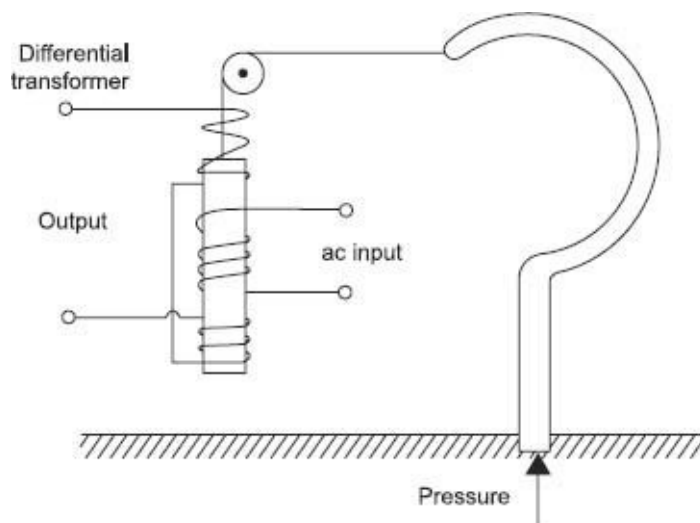

Figure 11.19 Pressure measurement with Bourdon tube and LVDT

11.7.4 Capacitive Transducers

In this type of transducers, a linear characteristics can be achieved by using a differential

arrangement for the capacitive displacement transducers. The arrangement using three plates is shown in Figure 11.20. P_1 and P_2 are fixed plates and M is the movable plate to which the displacement to be measured is applied. Thus, two capacitors are there whose differential output is taken.

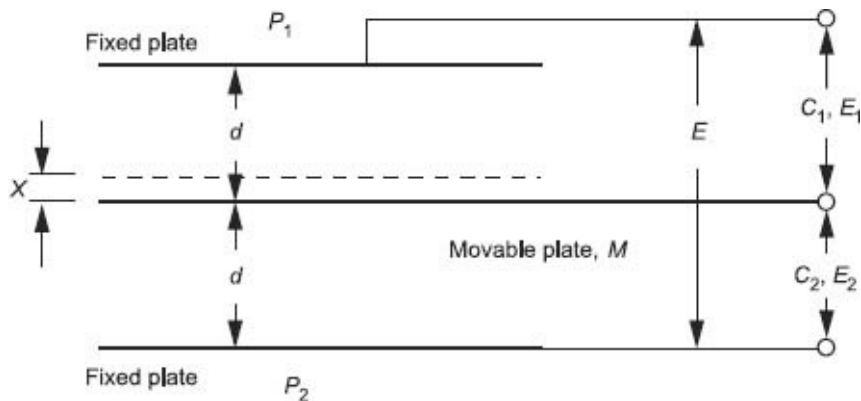

Figure 11.20 Differential arrangement of capacitive transducer

Let the capacitance of these capacitors be C_1 and C_2 respectively, when the plate M is midway between the two fixed plates, under this condition the capacitances C_1 and C_2 are equal.

$$C_1 = \frac{\epsilon A}{d} \text{ and } C_2 = \frac{\epsilon A}{d} \quad (11.20)$$

Where ϵ = Permittivity of the medium between the plates, A = Cross-sectional area of the plates, D = Distance between the plates.

An ac voltage E is applied across plates P_1 and P_2 and the difference of the voltages across the two capacitances is measured. When the movable plate is midway between the two fixed plates $C_1 = C_2$ and therefore $E_1 = E_2 = E/2$.

Voltage across C_1 is $E_1 = EC_2/(C_1 + C_2) = E/2$ (11.21)

and voltage across C_2 is $E_2 = EC_1/(C_1 + C_2) = E/2$ (11.22)

Therefore, differential output when the movable plate is midway $\Delta E = E_1 - E_2 = 0$

Let the movable plate be moved up due to displacement x , therefore the values C_1 and C_2 become different resulting in a differential output voltage.

Now, $C_1 = \frac{\epsilon A}{d-x}$ and $C_2 = \frac{\epsilon A}{d+x}$

$$E_1 = \frac{C_2 E}{C_1 + C_2} = \frac{\epsilon A/(d+x)}{\epsilon A/(d-x) + \epsilon A/(d+x)} E = \frac{d-x}{2d} E$$

And $E_2 = \frac{C_1 E}{C_1 + C_2} = \frac{\epsilon A/(d-x)}{\epsilon A/(d-x) + \epsilon A/(d+x)} E = \frac{d+x}{2d} E$

$$\text{Differential output voltage} = \Delta E = E_2 - E_1 = \frac{d+x}{2d} E - \frac{d-x}{2d} E = \frac{x}{d} E \quad (11.23)$$

Therefore, the output voltage varies linearly as the displacement x .

The use of a three-terminal variable differential circuit capacitor is shown in Figure 11.21. Spherical depressions of a depth of about 0.025 mm are ground into the glass discs. The depressions are coated with gold to form the two fixed plates of the differential capacitor. A thin stainless steel diaphragm clamped between the discs acts as the movable

plate.

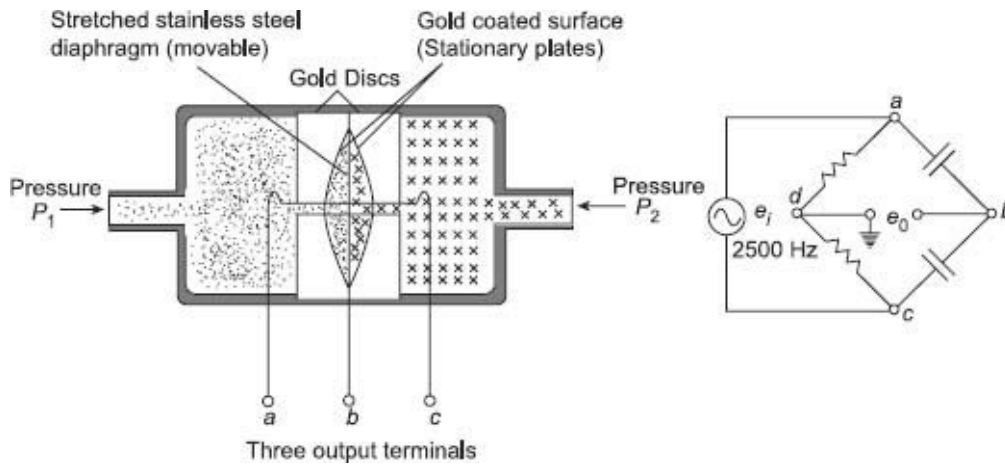

Figure 11.21 Capacitive transducer and bridge circuit

When equal pressures are applied (i.e., $P_1 = P_2$), the diaphragm is in the neutral position and the bridge is balanced. The output voltage e_0 , is zero under this condition. If one pressure is made greater than the other, the diaphragm deflects in proportional to the differential pressure, giving an output voltage e_0 , from the bridge terminals. This output voltage is proportional to the differential pressure. For an opposite pressure difference, the output voltage shows a 180° phase shift.

The use of capacitive transducers is not common because of low sensitivity. Also capacitive transducers require high carrier frequencies (typically, 2.5 kHz) for dynamic pressure measurement.

11.7.5 Photoelectric Transducers

The properties of a photoemissive cell or phototube are used in photoelectric transducers. The vacuum photoelectric cell consists of a curved sheet of thin metal with its concave surface coated with a photoemissive material, which forms the cathode, and the rod anode mounted at the centre of curvature of the cathode. The whole assembly is mounted in an evacuated glass envelope as shown in Figure 11.21. The material, coated cathode, emits electrons when light radiation strikes them. The emitted electrons from the cathode are collected by a positive electrode (anode) forming an electric current.

Figure 11.22 also shows the current versus voltage characteristics of a typical highly evacuated phototube. It is found from the curve that for the voltage above approximately 20 V, the output is nearly independent of the applied anode voltage but entirely depends upon the amount of incident light (denoted by its wavelength in Figure 11.21). The current through the phototube produced as a result of incident light is very small. This current is the output of the photo-electric transducers. As the current is in the order of some few μA , it must be amplified to provide a usable output.

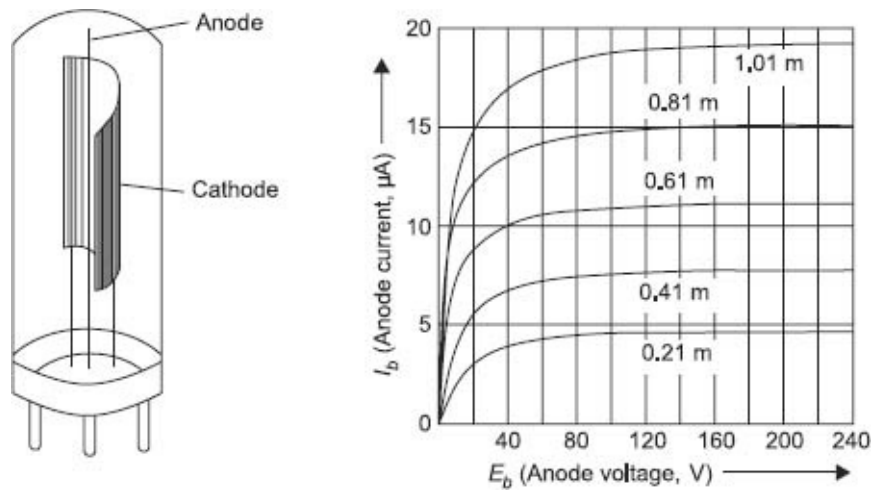

Figure 11.22 Photoemissive cell and its voltage vs current characteristic

The photoelectric transducer uses a phototube and a light source separated by a small window, whose aperture is controlled by the force summing device of the pressure transducer (Figure 11.23). The displacement of the force summing devices modulates quantity of incident light falling on the phototube. Applied pressure or force changes the position of the force summing device which in turn changes the position of the window thus causing a change in incident light. According to curves in Figure 11.22 a change in light intensity varies the photoemissive property at a rate approximately linear with displacement. These transducers either use a stable source of light or an ac modulated light.

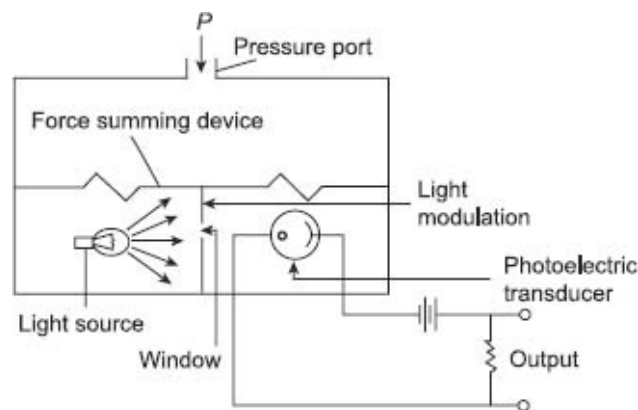

Figure 11.23 Pressure measurement using photoelectric transducer

11.7.6 Piezoelectric Transducers

When piezoelectric crystals are under the influence of some external force or pressure, they produce an emf. The force or displacement or pressure to be measured is applied to the crystal. The pressure is applied to the crystal through a force summing device. This causes a deformation which produces an emf which is a function of the deformation. This output emf may be measured to know the value of applied force and hence the pressure.

11.7.7 Ionisation Transducers

Ionisation is the process of removing an electron from an atom producing a free electron and a positively charged ion. Ionisation may be produced by the collision of a high speed electron from the atom. Figure 11.24 shows the essential features of an ionisation-type gauge. Electrons are emitted from heated cathode using a filament and are accelerated towards the grid, which is positively charged. Some of the electrons are captured by the

grid, producing grid current I_G . Electrons having high kinetic energy pass through and cause ionization of gas atoms.

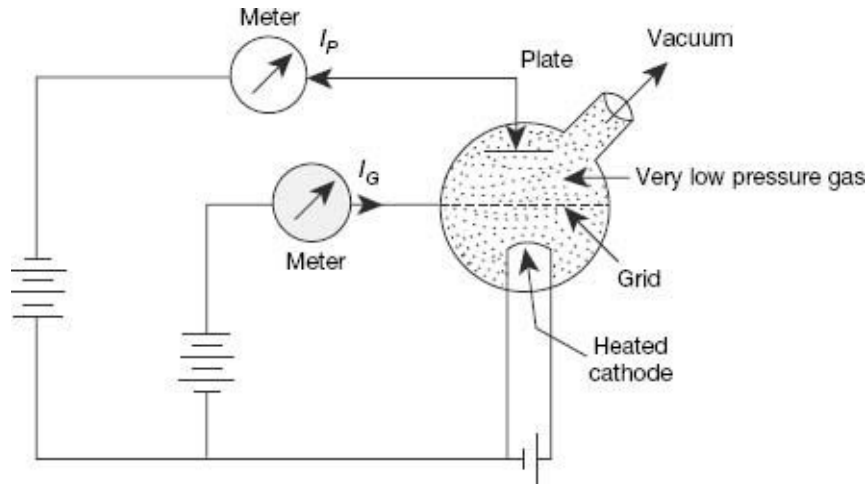

Figure 11.24 Ionisation type vacuum gauge for measurement of low pressure

The positive ions so produced are attracted to the plate, which is at negative potential and a current I_p is produced in the plate circuit. It is found that the pressure of gas is proportional to ratio of plate to grid current,

$$P = \frac{1}{S} \frac{I_p}{I_G} \tag{11.24}$$

where S = constant of proportionality

S is called the sensitivity of the gauge. A typical value of S for nitrogen is 20 torr^{-1} . However, the exact value must be determined by calibration of particular gauge since sensitivity S is a function of the geometry of the tube and the gas filled in it. Pressure that can be measured by ionisation gauge ranges from 10^{-3} to 10^{-8} mm of Hg.

11.7.8 Oscillation Transducers

These types of transducers use a force summing device to change the capacitance, C , or inductance, L , of an LC oscillation circuit. [Figure 11.25](#) shows the basic elements of LC transistor oscillator whose output frequency is affected by a change in the inductance of a coil. The change in inductance is caused by the force summing device acting upon an inductive device. The output of oscillator is a modulated output and can be demodulated and calibrated in terms of the pressure or force applied.

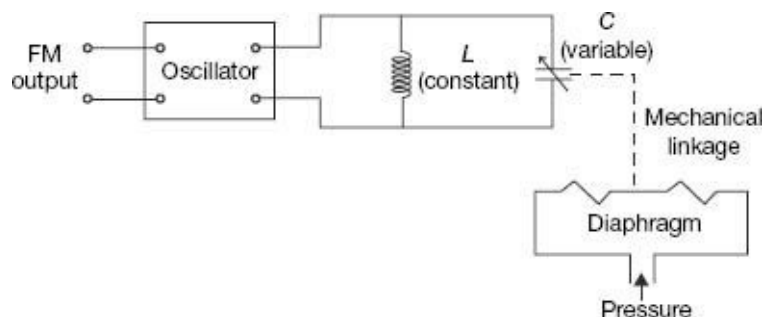

Figure 11.25 Basic elements of an oscillation transducer

EXERCISE

Objective-type Questions

1. Capacitive transducers have the advantages of
 - (a) very high input impedance
 - (b) very high input impedance, excellent frequency response, high sensitivity and not being affected by stray magnetic fields
 - (c) both (a) and (b)
 - (d) none of the above
2. The transducer that converts measurand into the form of pulse is called the _____ transducers.
 - (a) digital
 - (b) active
 - (c) analog
 - (d) pulse
3. A _____ is commonly used for the measurement of temperature
 - (a) photodiode
 - (b) strain gauge
 - (c) piezocrystal
 - (d) thermistor
4. LVDT windings are wound on
 - (a) copper
 - (b) ferrite
 - (c) aluminium
 - (d) steel sheets (laminated)
5. The strain gauges should have low
 - (a) resistance temperature coefficient
 - (b) resistance
 - (c) gauge factor
 - (d) all of the above
6. Which of the following devices can measure pressure directly?
 - (a) Bourdon tube
 - (b) Rotometer
 - (c) Both (a) and (b)
 - (d) Neither (a) nor (b)
7. The lower limit of useful working range of a transducer is determined by
 - (a) transducer error and noise
 - (b) minimum useful input level
 - (c) dynamic response
 - (d) cross-sensitivity

8. Which one of the following gives the gauge factor of a strain gauge?

(a) $\frac{VL}{L} \bigg/ \frac{VR}{R}$

(b) $\frac{VR}{R} \bigg/ \frac{VL}{L}$

(c) $\frac{VR}{R} \bigg/ \frac{VD}{D}$

(d) $\frac{VR}{R} \bigg/ \frac{Vr}{r}$

9. Self-generating type of transducers are

- (a) Inverse
 - (b) active
 - (c) passive
 - (d) secondary
10. The sensitivity factor of strain gauge is normally of the order of
- (a) 1 to 1.5
 - (b) 1.5 to 2.0
 - (c) 0.5 to 1
 - (d) 5 to 10
11. A pair of active transducers is
- (a) thermocouple, thermistors
 - (b) thermistors, solar cell
 - (c) solar cell, LVDT
 - (d) thermocouple, solar cell
12. The transducers that convert the input signal into the output signal, which is a continuous function of time, are known as
- (a) analog
 - (b) digital
 - (c) active
 - (d) passive
13. A strain gauge with a resistance of 250Ω undergoes a change of 0.150Ω during a test. The strain is 1.5×10^{-4} . Then the gauge factor is
- (a) 4
 - (b) 3
 - (c) 2
 - (d) 100
14. Consider the following transducers:
1. LVDT
 2. Piezoelectric
 3. Thermocouple
 4. Photovoltaic cell
 5. Strain gauge
- Which of these are active transducers?
- (a) 2, 3 and 5
 - (b) 1, 3 and 4
 - (c) 1, 2 and 5
 - (d) 2, 3 and 4
15. LVDT can be used for
- (a) angular velocity measurement of a column
 - (b) load measurement
 - (c) vibration measurement
 - (d) force measurement in a beam

16. Thermocouples
- require reference junction compensation
 - are most commonly used as temperature transducer
 - have an ion output voltage level
 - all of the above
17. A thermocouple temperature indicator with reference junction at room temperature has a time constant of 1 s. It is dipped in a hot bath of 120°C. If the room temperature is 20°C, after 1 s the thermocouple type temperature indicator will read
- 63.2°C
 - 100°C
 - 120°C
 - 140°C

Answers						
1. (b)	2. (a)	3. (d)	4. (b)	5. (a)	6. (a)	7. (a)
8. (b)	9. (b)	10. (b)	11. (d)	12. (a)	13. (a)	14. (d)
15. (d)	16. (d)	17. (c)				

Short-answer Questions

- What is the definition and importance of *primary sensing element*? Enlist some of the most commonly used primary sensing elements.
- Name different elastic pressure elements and give their useful working range and other characteristics.
- Distinguish between active and passive electrical transducers and give some examples of them.
- What are the differences between sensors and transducers?
- Describe a method for measurement of differential pressure.
- What is an electrical transducer? What are the basic requirements of a transducer? Give the classification of a transducer.
- Explain how thermistor can be used for temperature measurement.
- What are the advantages and uses of the LVDT?
- What are capacitive transducers? What are their advantages and disadvantages?

Long-answer Questions

- What are thermistors? Explain the working, construction and applications of thermistors. Compare resistance temperature characteristics of a typical thermistor and platinum.
- Write down the construction and working principle of a thermocouple. Compare different thermocouple materials. Describe the advantages, disadvantages and applications of thermocouple.
- What is an LVDT? Explain its working principle with necessary diagrams and characteristics. What are its advantages and uses?
- Explain the working principle of a linear variable differential transformer (LVDT). Show how it can be used for measuring small mechanical displacements.
- Describe with suitable diagrams the working principle of strain gauges. Describe the terms *Poisson's ratio* and *gauge factor*.
- With a neat sketch, briefly describe the principle of electromagnetic flow meter. What are the advantages of an electromagnetic flow meter?
- What are the errors that occur that during the measurement using a thermocouple?
 - What are the secondary transducers used for pressure measurement? Explain any one them briefly.

12.1 INTRODUCTION

Magnetic quantities are measured using a variety of different technologies. Each technique has unique properties that make it more suitable for particular applications. These applications can range from simply sensing the presence or change in the field to the precise measurements of a magnetic field's scalar and vector properties. Magnetic measurements are most difficult to make and essentially less accurate than electrical measurements for two reasons. First, in magnetic measurement, flux is not measured as such, but only some effect produced by it, such as the voltage induced by a change of flux. As a second and greater difficulty, flux paths are not defined as are electrical circuits—difficulties are definitely faced in precision ac bridges in making the electrical circuits, but the magnetic situation is radically worse and not subject to the same control.

12.2 TYPES OF MAGNETIC MEASUREMENTS

Magnetic measurements can be divided into two general classes: direct-current (dc) tests and alternating-current (ac) tests. Although quite different methods and objectives are found, these are the two most distinctly defined classes of tests. The dc branch may be further subdivided into measurement of field strength, flux, permeability, B - H curves and hysteresis loops. Such tests are most generally made upon solid materials, the ac test methods being used chiefly for laminated materials. The ac measurements are concerned mainly with losses in magnetic materials under conditions of alternating magnetisation.

12.3 THE BALLISTIC GALVANOMETER

The ballistic galvanometer is used to measure the quantity of electricity passed through it. This quantity in magnetic measurements is the result of an emf instantaneously induced in a search coil connected to the galvanometer terminals, when the magnetic flux interlinking with the search coil is changed. Such a galvanometer is usually a D'Arsonval type, since this type is least affected by external magnetic fields. It does not show a steady deflection when in use, owing to the transitory nature of the current passing through, but gives a "throw" which is proportional to the quantity of electricity instantaneously passed through it. In the ballistic case the current flow takes place in a short period of time. The coil receives a momentary impulse, which causes it to swing to one side and then return to rest, either gradually or after several oscillations, depending on the damping. The deflection is

read at the extreme point of the first throw.

The discharge through the ballistic galvanometer must occur in a short time, that is, before the coil has moved appreciably from its rest position, in order that the throw shall be directly proportional to the quantity of electric discharge. Galvanometers for ballistic use are designed, according to have a longer period than that of ordinary type. The long period is secured by large inertia of the moving system and small restraining torque of the suspension. The inertia has been secured in some galvanometers by the addition of dead weight to the moving system. It is preferable to design the coil for greater width so that the added copper not only increases the inertia but also enhances the sensitivity.

Equations describing the behaviour of a ballistic galvanometer may be derived as follows. The torque developed by the coil at any point of time is

$$T_d = Bi \times 2Ln \frac{W}{2} = i(BLnW) = K_1 i \quad (12.1)$$

where L , W and n are respectively, the length, width and number of turns of the coil, and B is the air gap flux density.

The torque of acceleration is

$$T_a = J \times \text{Acceleration} = J \frac{d\omega}{dt} \quad (12.2)$$

where J is the moment of inertia of the coil about its axis and w is the angular velocity. Now if the coil is close to its zero position during the time the discharge takes place, the torque of the suspension is practically zero, and if the damping torque is negligible in comparison with the driving torque during this time, the value of derived torque may be equal. Therefore, during this short discharge period

$$J \frac{d\omega}{dt} = K_1 i \quad (12.3)$$

By integrating, we get,

$$J\omega \Big|_{\omega=0}^{\omega=\omega_0} = K_1 \int_{t=0}^{t_0} i dt \quad (12.4)$$

where, the subscript zero refers to conditions at the end of the discharge time. The integral form on the right side of [Eq. \(12.4\)](#) is the quantity of charge that has passed through the coil during this period. Therefore,

$$\omega_0 = \frac{K_1}{J} Q \quad (12.5)$$

The above expression indicates that the velocity which the coil acquires from the impulse and with which it begins its swing is proportional to the quantity of charge that passed through it. This depends on [Eq. \(12.3\)](#), which in turn, is true only if the entire discharge takes place before the coil has moved appreciably from its rest position. This is the reason for the requirement of a long period for the galvanometer swing.

During the actual motion, the deflection torque is zero and the equation of motion is

$$J \frac{d^2\theta}{dt^2} + D \frac{d\theta}{dt} + S\theta = 0 \quad (12.6)$$

where, D is damping constant, S is the control constant and θ is the deflection in radians.

The solution of this equation is

$$\theta = Ae^{m_1 t} + Be^{m_2 t} \quad (12.7)$$

where, A and B are constants and $m_1, m_2 = \frac{-D \pm \sqrt{D^2 - 4JS}}{2J}$. Here, the damping is small and as a

result, m_1 and m_2 are imaginary. In the present application, the initial conditions are

$$\theta = 0 \text{ and } \frac{d\theta}{dt} = \omega_0 \text{ at } t = 0 \quad (12.8)$$

Under this condition, the solution may be written as

$$\theta = e^{-\frac{\pi}{2J}} \cdot \omega_0 \cdot \frac{\sin \beta t}{\beta} \quad (12.9)$$

where, $\beta = \sqrt{\frac{S}{J}}$

Notice in Eq. (12.9) that deflections are proportional to ω_0 , which from Eq. (12.5) is proportional to Q . The deflection of the galvanometer may accordingly be used as a measure of quantity of electricity discharged through it.

The amplitude of the first swing θ_1 , for “undamped” case ($D \approx 0$) is from Eq. (12.9)

$$\theta_1 = \omega_0 \sqrt{\frac{J}{S}} \quad (12.10)$$

The ratio of successive swings with damping present is found by exponential multiplier in Eq. (12.9) for a time interval such that $\beta t = \pi$ or $t = \pi/\beta$. The ratio of successive swings is

$$r = \frac{\theta_1}{\theta_2} = e^{\left(\frac{\pi}{2}\right)\left(\frac{D}{J\beta}\right)} \quad (12.11)$$

The natural logarithm of this ratio is referred to as “logarithmic decrement” of the galvanometer and has the value

$$\lambda = \ln\left(\frac{\theta_1}{\theta_2}\right) = \frac{\pi D}{2 J\beta} \quad (12.12)$$

The third swing may be found in the same manner as follows.

$$\frac{\theta_1}{\theta_3} = \frac{\theta_1}{\theta_2} \times \frac{\theta_2}{\theta_3} = r^2 \quad (12.13)$$

In general,

$$\frac{\theta_1}{\theta_n} = r^{n-1} \quad (12.14)$$

In case of critical damping, Eq. (12.9) will be modified as follows.

$$\theta = \omega_0 e^{-(D/2J)t} \quad (12.15)$$

and
$$\omega = \frac{d\theta}{dt} = \omega_0 e^{-\left(\frac{D}{2J}\right)t} \left(1 - \frac{D}{2J}t\right) \quad (12.16)$$

Maximum deflection is found for $\omega = \frac{d\theta}{dt} = 0$ or $t = 2J/D$ from Eq. (12.16). Substitute this value in Eq. (12.15) and call the deflection θ_1 ; then

$$\theta_1 = \omega_0 \frac{2J}{D} \cdot \frac{1}{e} \quad (12.17)$$

$$\text{or} \quad \theta_1 = \omega_0 \sqrt{\frac{J}{S}} \cdot \frac{1}{e} \quad (12.18)$$

Since, $D^2/4J^2 = S/J$ for critical case.

It is interesting to compare Eq. (12.18) with Eq. (12.10). The deflection in the critically damped case is $1/e$ or 36.8 % of the undamped deflection, but it is still a direct measure of ω_0 or Q . The loss of sensitivity is not much serious, since conditions can usually be arranged to give ample deflection.

Summarising the results of this study in the following equation of the charge passing through the galvanometer,

$$Q = K_2 \cdot \theta \quad (12.19)$$

The usual working units in Eq. (12.19) are

K_2 = galvanometer sensitivity in microcoulombs/millimetre deflection

θ = deflection in millimetres

Q = charge in microcoulombs

In theoretical study, θ was in radians and Q in coulombs, but the units above are ones in common use in laboratory work. The sensitivity K_2 has been shown to depend on the damping. Curves may be found showing the relationship of sensitivity to damping in order to give an idea of the nature of variation. The sensitivity for a set of measurements, however, should be obtained by calibrating conducted under the actual conditions of use.

12.3.1 Measurement of Magnetic Flux by Ballistic Galvanometer

To sense magnetic flux of a bar magnet, it is surrounded by a search coil or pick-up coil that is connected in series with a variable resistor and a galvanometer. The circuit diagram of this measurement scheme is shown in Figure 12.1. The series resistor is set to give critical damping and it may also be used to control sensitivity. The sensitivity may be controlled satisfactorily by adjusting the number of turns in the search coil. When the magnet is suddenly withdrawn from the coil, an impulse of short duration is produced in the galvanometer and the first deflection of the galvanometer may be taken as a measure of the flux. The induced voltage in the search coil in the process is

$$e = N \frac{d\phi}{dt} \text{ volts} \quad (12.20)$$

where, flux is measured in webers and N is the number of turns in the search coil. If R is the total resistance of the circuit, including search coil, series resistor and galvanometer, the momentary current flowing through the circuit is

$$i = \frac{e}{R} = \frac{N}{R} \frac{d\phi}{dt} \text{ amperes} \quad (12.21)$$

$$\text{or} \quad \int_{t=0}^{t_0} i dt = \frac{N}{R} \int_{\phi=\Phi}^0 d\phi \quad (12.22)$$

Neglecting the sign, the quantity of charge passed through the galvanometer is

$$Q = \frac{N\Phi}{R} \text{ coulombs} \quad (12.23)$$

Deflection of the galvanometer is

$$\theta_1 = \frac{Q}{K_2} = \frac{N\Phi}{K_2 R} \quad (12.24)$$

or
$$\Phi = \frac{K_2 R \theta_1}{N} \text{ webers} \quad (12.25)$$

While performing this test, two points should be noted: first, the change of flux must be made in a short time interval in comparison with the period of the instrument; second, the galvanometer is here used in a closed circuit and hence is subject to electromagnetic damping. The sensitivity factor, K_2 , must be properly evaluated for the resistance used in the test measurements.

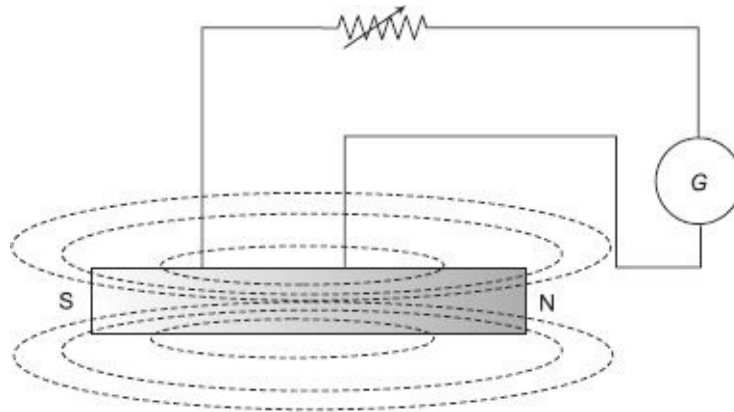

Figure 12.1 Measurement of magnetic flux by ballistic galvanometer

12.3.2 Calibration of the Ballistic Galvanometer

This may be carried out in a number of ways. Some of the methods are as follows:

1. By Means of a Capacitor

A capacitor which has been charged to a known voltage is discharged through the galvanometer. The circuit diagram of the scheme is shown in Figure 12.2. The resistor and S_2 switch are used to bring the galvanometer to rest quickly after a deflection. The capacitor is charged by the upper position of the S_1 switch and discharged by temporary contact in the lower position. The quantity of electricity discharge can be calculated from the known voltage and capacitance of the capacitor i.e. $Q = CE$, so the constant K_2 is derived from the charge divided by the observed deflection. This, as described, is the undamped sensitivity, because, the galvanometer circuit has infinite resistance. A shunt may be added, as shown by the dotted line and a new calibration can be obtained. The shunt also gives damping, and if the shunt is much below the critical value, the action is sluggish. Damping conditions may be improved by a combination of shunt and series resistances.

This method is not in general used owing to the difficulty of determining exactly the capacitance of the capacitor under all conditions and also because of the fact that the damping of the galvanometer during calibration is different from that during testing.

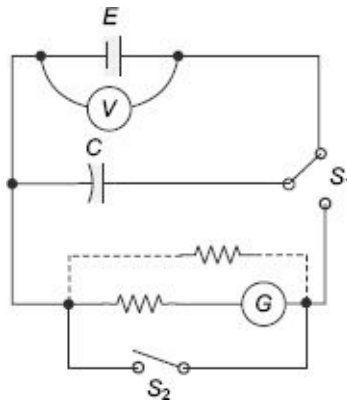

Figure 12.2 Calibration of a ballistic galvanometer by capacitor

2.By Means of a Standard Solenoid

This method is most commonly used for calibration purposes. A standard solenoid consists of a long coil of wire wound on a cylinder of insulating and nonmagnetic material. There may be one or more layers of wire, but the design is such that the axial length of the solenoid is large compared with its mean diameter. Usually, the axial length is at least 1 metre, while the mean diameter is of the order of 10 cm. The winding should be uniform and the number of turns per metre axial length should be such that a field strength, H , of 10,000 A/m or more is obtained at the centre of the coil when carrying its maximum allowable current. This type of dimensions set a practically uniform field near the centre. The test coil or search coil wound closely around (or else placed inside) the middle of the long solenoid as shown in Figure 12.3. Here, the calibration is done for flux measurements by means of a known flux, and the calibration and damping remain constant if the same total resistance in the galvanometer circuit is maintained at all times.

The flux linking the search coil is given by

$$\Phi = 4\pi \times 10^{-7} N_1 I_1 A \text{ webers} \quad (12.26)$$

where, N_1 = primary turns per metre length of solenoid

I_1 = primary current in amperes

A = cross section area of test coil in square metres, if placed inside

= cross section area of solenoid, if test coil is closely wound outside.

Thus, the circuit is operated by throwing the reversing switch from one position to other. As a result, this arrangement creates a flux change twice as great as above, so by substitution in (12.23)

$$Q = \frac{8\pi N_1 I_1 A N_2}{R} \times 10^{-7} \text{ coulomb} \quad (12.27)$$

where, N_2 = turns on the test coil

R = resistance of the test coil and galvanometer circuit

The sensitivity factor K_2 can thus be established from Q and the observed deflection. The calibration for flux measurements may be placed in convenient form, once K_2 is evaluated. If the galvanometer is used to measure an unknown flux, it may be written that

$$\Phi_x = \frac{\theta_x K_2 R}{N_x} \quad (12.28)$$

where, Φ_x = unknown flux change

θ_{1x} = deflection in millimetres

N_x = number of turns used in the search coil

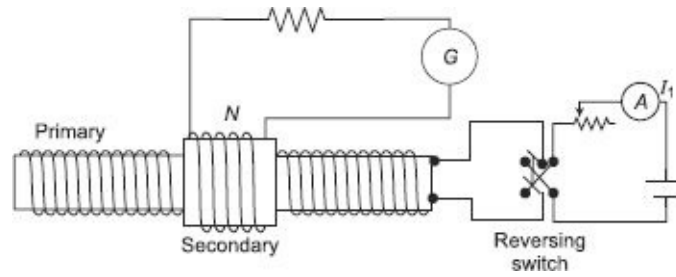

Figure 12.3 Calibration of ballistic galvanometer by solenoid

3. By Means of a Mutual Inductance

The solenoid and search coil provide a calculable mutual inductance, but it is a common practice to use a variable mutual inductor. This procedure has the advantage that a large range of calibration points can be obtained, and the mutual inductor is usually smaller and more convenient than the long solenoid. This test is practically same as the earlier test, but expressed in a somewhat different way. If the mutual inductance between test coil and solenoid is known, following the circuit connection as shown in Figure 12.4, a deflection θ_1 produced by the reversal of a known primary current I is observed.

By changing primary current,

$$e_2 = M \frac{di_1}{dt} \quad (12.29)$$

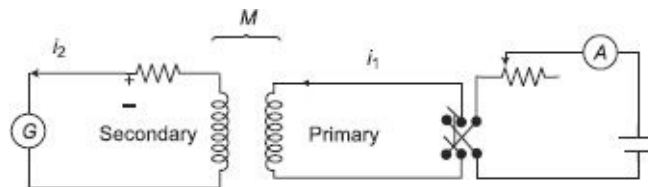

Figure 12.4 Calibration of ballistic galvanometer by mutual inductor

Let R be the total resistance of galvanometer circuit.

Galvanometer current,

$$i_2 = \frac{M}{R} \frac{di_1}{dt} \quad (12.30)$$

By integration,

$$\int_{t=0}^{t_0} i_2 dt = \frac{M}{R} \int_{-I}^I di_1 \quad (12.31)$$

So,

$$Q = \frac{2MI}{R} \quad (12.32)$$

and
$$K_2 = \frac{Q}{\theta} = \frac{2MI}{R\theta_1} \quad (12.33)$$

A fluxmeter is superior over the ballistic galvanometer for some kinds of magnetic measurements. It is a special form of ballistic galvanometer with some modifications, like, the torque of the suspension is made very small, and the electromagnetic damping is very heavy. Apart from portability, it has the advantage that unlike a ballistic galvanometer, the flux change for short time is not necessary. The deflection obtained for a given flux change does not depend on the time taken making the change of flux.

The construction of the metre is shown in [Figure 12.5](#). The coil is supported by a silk fibre from a spring support. The current connections are made by spirals having the maximum possible spring effect. To make the restoring torque of the system as nearly zero as possible, the suspension and spirals are present in the construction. The search coil and moving coil are of low resistance to get a heavily overdamped moving system during electromagnetic action. The metre coil follows flux changes very rapidly and is practically deadbeat in its action. After being deflected, the coil stays almost stationary and moves extremely slowly toward the zero position; thus, the fluxmeter is much easier to read than a ballistic galvanometer. A mechanical or electrical return arrangement must be used to bring the pointer back to zero. Fluxmeters are usually of portable type, carrying a pointer and scale.

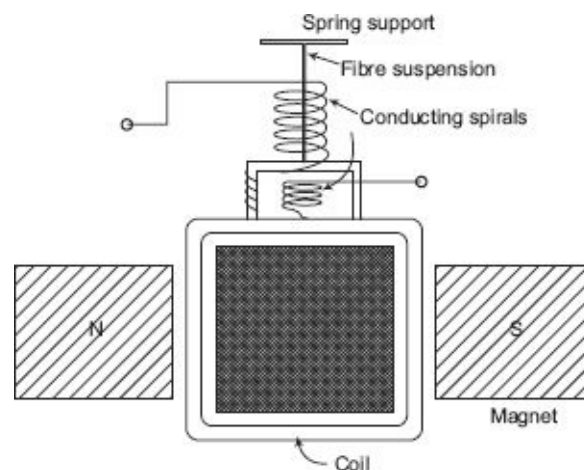

Figure 12.5 Construction of a fluxmeter

The derivation for the ballistic galvanometer was based on the assumption that discharge through the coil takes place before it moves appreciably from the rest position and the damping has a negligible effect during this period. This is not true for a fluxmeter because of the heavy damping action. With a low circuit resistance, a large accelerating torque acts on the metre coil whenever the search-coil voltage exceeds the back voltage caused by the motion of metre coil. As a result, the metre coil responds quickly and is well along in its movement while the flux change is under progress, regardless of whether the flux change is fast or slow. The almost complete absence of a counteracting suspension torque permits the metre to add the effects of a separate flux changes over a short period of time and gives independence of the overall time, within reasonable time.

The voltage generated in the fluxmeter coil by its motion becomes the controlling element in this metre because of the low resistance of the moving system and of the absence of torque from the suspension. The coil voltage could be expressed as the change of the flux linkages, but since the turns and magnet strength are constant it is more

convenient for this purpose to relate voltage to coil velocity or

$$e_m = K_1 \frac{d\theta}{dt} \tag{12.34}$$

where $K_1 = BLnW$ is the coil constant.



Figure 12.6 Analysis of fluxmeter action

The quantities required in the analysis are shown in the [Figure 12.6](#). The voltage induced in the search coil is indicated by a small generator marked e_g and the back emf caused by the motion of the fluxmeter coil by another generator, e_m . In the electrical circuit,

$$e_g = iR + L \frac{di}{dt} + e_m \tag{12.35}$$

Using [Eq. \(12.34\)](#) in [Eq. \(12.35\)](#) and solving for i ,

$$i = \frac{N}{R} \frac{d\phi}{dt} - \frac{K_1}{R} \frac{d\theta}{dt} - \frac{L}{R} \frac{di}{dt} \tag{12.36}$$

The equation of coil motion can be written with the term for suspension torque omitted. The net torque is equated to the amount produced by the current

$$J \frac{d^2\theta}{dt^2} + D \frac{d\theta}{dt} = K_1 i \tag{12.37}$$

where, J = moment of inertia

D = constant of friction and air damping

Substituting i and after simplifying,

$$J \frac{d^2\theta}{dt^2} + \left(\frac{K_1^2}{R} + D \right) \frac{d\theta}{dt} = \frac{K_1 N}{R} \frac{d\phi}{dt} - \frac{K_1 L}{R} \frac{di}{dt} \tag{12.38}$$

Now, integrating all with respect to time.

$$\left(K_1 + \frac{DR}{K_1} \right) (\theta_1 - \theta_2) = N(\phi_1 - \phi_2) \tag{12.39}$$

where, $R = R_c + R_m$

The air-damping effect and the resistance are both small, and accordingly, the first term is nearly equal to K_1 . Therefore,

$$K_1(\theta_1 - \theta_2) = N(\phi_1 - \phi_2) \tag{12.40}$$

[Equation \(12.40\)](#) indicates an interesting physical fact. The quantity on the right is the change of flux linkage with search coil, and the quantity on the left is the change of flux linkage with the metre coil. If the operator withdraws a magnet from the search coil, reducing the flux linkage with that part of the circuit, the metre coil moves in a direction

to restore the flux linkages and thus to keep the total constant for the circuit. The fluxmeter does this within the limits set by the degree to which air damping and suspension torque are negligible.

The effect of shunting the metre by a simplified form as shown in [Figure 12.7](#), can be derived. Since induced terms do not appear in the result, at the starting they are dropped in study.

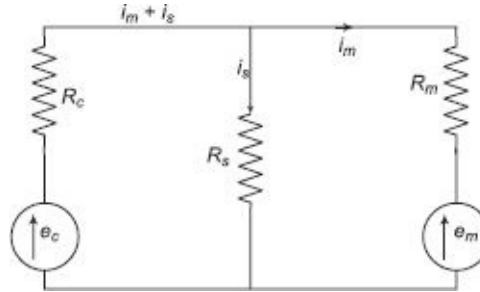

Figure 12.7 Simplified circuit for a shunted fluxmeter

According to the above figure, two circuit equations can be written,

$$N \frac{d\phi}{dt} = (i_m - i_s)R_c + i_m R_m + K_1 \frac{d\theta}{dt} \quad (12.41)$$

$$i_s R_s = i_m R_m + K_1 \frac{d\theta}{dt} \quad (12.42)$$

By substituting for i_s in [Eq. \(12.41\)](#) of its value from [Eq. \(12.42\)](#),

$$N \frac{d\phi}{dt} = i_m \left(R_c + R_m + \frac{R_c R_m}{R_s} \right) + K_1 \frac{R_c + R_s}{R_s} \frac{d\theta}{dt} \quad (12.43)$$

If it is solved for i_m from [Eq. \(12.43\)](#), substituting the value in [Eq. \(12.37\)](#)

$$\left[K_1 + \frac{D}{K_1} \left(\frac{R_c R_s}{R_c + R_s} + R_m \right) \right] (\theta_2 - \theta_1) = \frac{N R_s}{R_c + R_s} (\phi_2 - \phi_1) \quad (12.44)$$

and in the approximate form

$$(\theta_2 - \theta_1) = \frac{N}{K_1} \frac{R_s}{R_c + R_s} (\phi_2 - \phi_1) \quad (12.45)$$

Comparison of [Eq. \(12.40\)](#) and [Eq. \(12.45\)](#) shows that the main effect of the shunt is to apply a shunting factor $R_s/(R_c + R_s)$ to the reading. The resistance circuit, as shown in the correction term in [Eq. \(12.39\)](#) or [Eq. \(12.44\)](#), is not of extreme importance. However, for accurate work, the total resistance should be brought to the same value used in calibration by the addition of a series resistance if necessary.

12.5

USES OF BALLISTIC GALVANOMETER AND FLUXMETER

Flux measurements may be done in open or close frame electromagnets when the current in the magnet coil be either switched on and off or reversed. A search coil with suitable number of turns needs to be wound around the magnet. If the flux in the field pole of a large motor or generator is being measured, even a single-turn search coil may give

enough deflection, and it will be necessary to shunt the metre. The fluxmeter has the advantage in such measurements that the flux need not to be changed in a short time—changes should be made too rapidly, particularly in large machines.

The flux of a permanent magnet can be measured if the search coil can move on and off the magnet. It should be placed always in the same position with respect to the magnet to get consistent result.

The field strength between magnet poles can be measured if there is room to insert and remove the search coil. Another method, used in fields of considerable extent is a “flip coil”, which is a coil mounted so that it can be rotated an exact 180° in a short period of time. The fluxmeter indication can then be interpreted in terms of field strength.

B-H curves of a ring-shaped samples of magnetic material may be obtained by a ballistic galvanometer or fluxmeter in conjunction with search and magnetising coils would around the sample. Similar tests are run on straight-strip samples by means of “permeameter”.

12.6

MEASUREMENT OF FLUX DENSITY

Measurement of flux density inside a specimen can be done by winding a search coil over the specimen. This search is known as a “B-coil”. This search coil is then connected to a ballistic galvanometer or to a fluxmeter. Scheme of measuring the flux density in a ring specimen is shown in [Figure 12.8](#). Let, the current I is flowing through magnetising winding wound around the specimen. A search coil with suitable number of turns is wound around the specimen and connected through a resistance and calibrating coil, to a ballistic galvanometer.

The current through the magnetising coil is reversed and therefore the flux linkages of the search coil change inducing an emf in it. This emf sends a current through the ballistic galvanometer causing it to deflect.

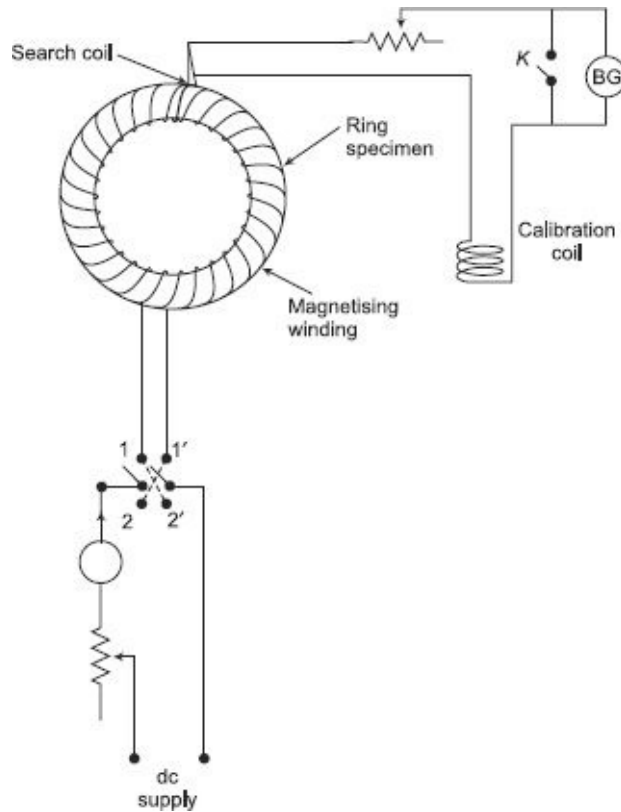

Figure 12.8 Circuit to measure flux density of a ring specimen

ϕ = flux linking the search coil

R = resistance of the ballistic galvanometer circuit

N = number of turns in the search coil

and t = time taken to reverse the flux

Average emf induced in the search coil

$$e = N \frac{d\phi}{dt} = 2 \frac{N\phi}{t}$$

So, average current through the ballistic galvanometer is,

$$i = 2N \frac{\phi}{R \cdot t}$$

Charge passing through it,

$$Q = i \cdot t = \frac{2N\phi}{R}$$

Let θ_1 be the deflection of the galvanometer. Charge indicated by the galvanometer = $K_2\theta_1$

So,
$$\frac{2N\phi}{R} = K_2\theta_1$$

or flux
$$\phi = \frac{RK_2\theta_1}{2N}$$

In uniform field and with search coil turns at right angles to the flux density vector, the flux density,

$$B = \frac{\text{Flux}}{\text{Area}} = \frac{\phi}{A_s} = \frac{RK_2\theta_1}{2NA_s}$$

where, A_s = cross-section area of the specimen.

Thus, observing the throw of the ballistic galvanometer, flux density may be measured.

For the above analysis, it is assumed that the flux remains uniform throughout the specimen and that the effective cross-section area of the search coil is equal to the cross-section area of the specimen. However, search coil is usually of larger area than the specimen and thus the flux linking the search coil is the sum of the flux confined in the specimen and the flux which is present in air space between the specimen and the search coil.

So, Flux observed = Actual flux in the specimen + Flux in the air space between specimen and search coil.

or,

$$B'A_S = BA_S + \mu_0 H(A_c - A_s)$$

Hence, actual value of the flux density

$$B = B' - \mu_0 H \left(\frac{A_c}{A_s} - 1 \right)$$

where, B' = apparent or observed value of the flux density

B = actual or true value of the flux density in the specimen

A_s = cross-section area of the specimen

A_c = cross-section area of the coil

12.7

MEASUREMENT OF MAGNETISING FORCE (H)

A ballistic galvanometer and a search coil may be used to measure the magnetising force of a constant magnetic field. The value of H inside the specimen may either be obtained from the calculations with data of magnetising coil and the specimen or from measurements made from outside the specimen. Direct measurement cannot be done. If the magnetising force is to be determined in the air gap, the search coil is placed in the air gap itself. In case of testing ferromagnetic materials, the magnetising force, within the specimen may be determined by measuring the magnetising force on its surface, since the tangential components of the field are of equal in magnitude for both sides of the interface. The search coil, as placed in [Figure 12.9](#), measures flux density in air, B_0 . This search coil is called an “H coil”. While the flux densities encountered in iron testing, there is usually no trouble in getting a good sensitivity by using a B -coil of sufficient turns but there is some difficulty in achieving adequate sensitivity in the H coil placed at the surface. At the first instance, its cross-sectional area is much smaller than the coil surrounding the specimen and then H is not constant across the section. Secondly, the permeability of iron is very large as compared to that of air and therefore flux density B_0 , in the search coil, is very small compared to that in the specimen. The value of the flux density B_0 in H coil is measured in a similar way as described before for measuring of B in a specimen.

Magnetising force, $H = B_0/\mu_0$

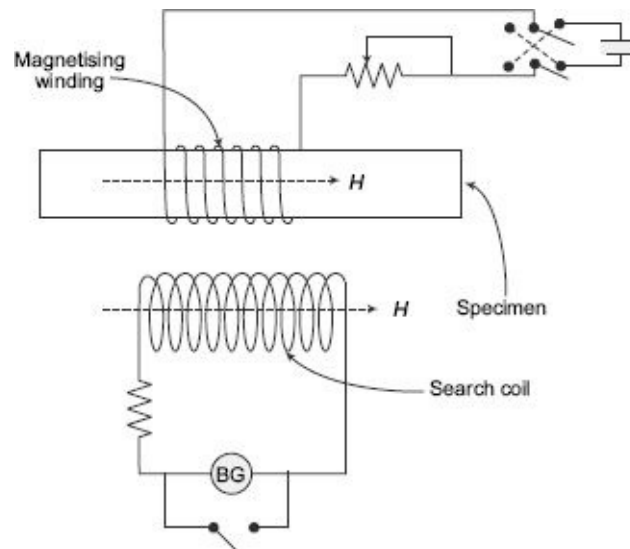

Figure 12. 9 Circuit diagram to measure magnetising force

Testing Ring and Bar Specimens

The ballistic methods which are done on ring specimens give highest accuracy provided the test conditions are controlled properly. The main advantage of ring specimens is that the end effects are absent in ring specimens and test errors due to magnetic leakage are not encountered.

To avoid magnetic leakage, a uniform distribution of mmf is maintained by a uniformly wound magnetising winding on the ring sample. The magnetising force is usually calculated in terms of mean diameter of the ring and the mmf in the magnetising winding. Since, the inner periphery of ring specimen is smaller than the outer periphery, the magnetising force and the flux density become nonuniform over the cross-section of the ring. The error involved depends upon the ratio of mean diameter to the radial width of the ring. But, when this ratio is more, both magnetising force and the flux density are sufficiently uniform over the cross-section of the specimen and as a result, the error involved in test result is not significant.

The ring specimens may take on of the following shapes:

1. Laminates

It is the common form for isotropic sheet material. The ring is assembled with the direction of rolling of individual laminations distributed radially, in order that the test should exhibit results corresponding to mean properties of the material.

2. Clock-spring

A long strip of material may be wound in the form of spiral to form a ring. This form is suitable for testing anisotropic materials, i.e., grain-oriented steel.

3. Solid

Solid rings are prepared by either casting or forging. Ring specimens are also used for testing powder or dust core material.

The ring is prepared for the test by first winding on it a thin layer of insulating tape and

then a search coil of a suitable number of turns, evenly distributed around the ring. Insulating tape is applied over the search coil, and then the magnetising coil is wound on the ring. The magnetising coil should be spaced uniformly around the ring and must consist of a suitable number of turns of wire of adequate current-carrying capacity to give the number of ampere-turns required for the tests.

12.8

DETERMINATION OF MAGNETISING CURVE

There are two methods used to determine the magnetising curve or B - H curve of a specimen.

1. Method of Reversal

A ring specimen with known dimensions is used for the test. At first, ring specimen is prepared by placing search coil, and magnetising coil with proper insulation arrangement as mentioned earlier. The arrangement of the test circuit is shown in [Figure 12.8](#).

After demagnetising the test is started by setting the magnetising current to its lowest test level. At that time, the galvanometer switch is closed, the iron specimen is brought into a reproducible cyclic magnetic state by throwing the reversing switch S backward and forward about twenty times. The K switch is now opened and the value of flux corresponding of this value of H is measured by reversing the switch S and recording the throw of galvanometer. The value of flux density corresponding to this H can be calculated by dividing the flux by the cross-section area of the specimen. This procedure is repeated for various values of H to maximum testing point. The B - H curve may be plotted from the measurement values of B corresponding to the various values of H .

2. Step-by-step Method

For this test, the circuit diagram is shown in [Figure 12.10](#). In this test the magnetisation winding of the ring specimen is supplied from a potential divider having few tappings. The tappings are arranged so that the magnetisation force H may be increased in suitable number of steps, upto desired maximum value. Before testing the specimen, it must be demagnetised.

Keeping the switch S_2 on the tap 1 position, the switch S_1 is closed. Current flow in the magnetising winding sets up a magnetising force, H_1 which in turns increases the flux density in the specimen, from zero to some value B_1 , and corresponding throw of galvanometer is observed. The B_1 value can be calculated from the throw of the galvanometer. H_1 value may be calculated from the reading of the ammetre, connected to the magnetising winding circuit. The magnetising force is then increased to some value H_2 by switching S_2 suddenly to the tapping 2 and the corresponding increase in flux density ΔB is determined from the throw of the galvanometer. Then the flux density B_2 corresponding to magnetising force H_2 is calculated as $B_2 = B_1 + \Delta B$. The process is repeated for other values of H up to the maximum point and the complete B - H curve thus drawn as shown in [Figure 12.11](#).

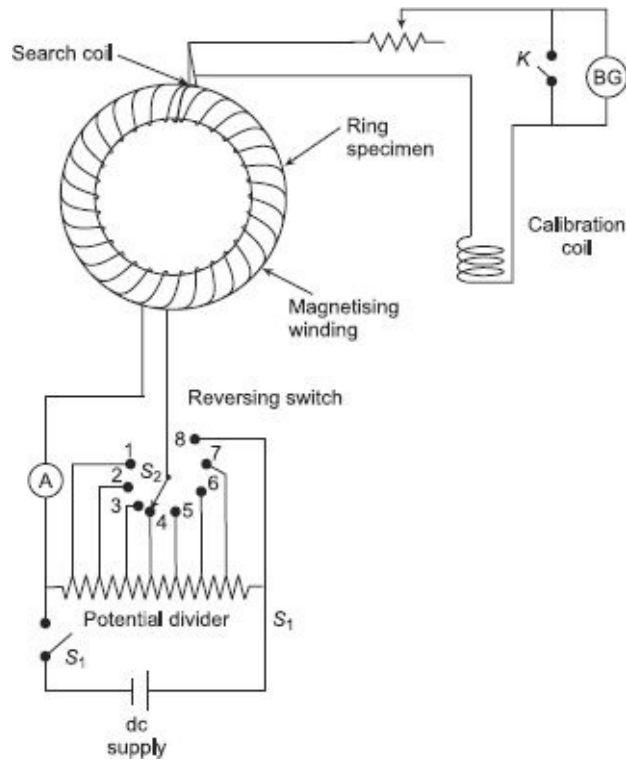

Figure 12.10 Circuit to measure magnetising curve

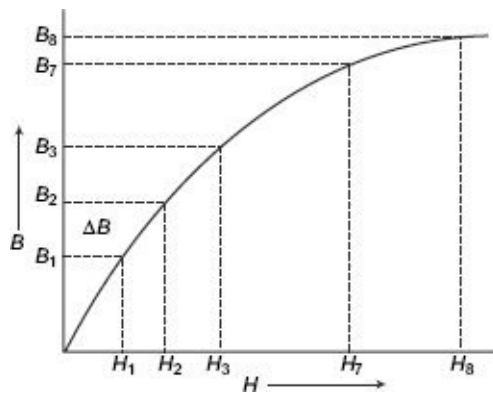

Figure 12.11 Magnetising curve

12.9

DETERMINATION OF HYSTERESIS LOOP

1. Step-by-step Method

The determination of the hysteresis loop by this method is carried out simply by continuing the procedure described in the previous section where the $B-H$ curve was obtained. After reaching the point of maximum H with S_2 on the tapping 8, the magnetising current is then reduced, in steps to zero by moving S_2 down through tapping points 8,7,6...2,1. After the reduction of the magnetising force to zero, negative values of H are obtained by reversing the reversing supply to the potential divider and then moving the switch S_2 in steps as before.

2. By Method of Reversal

The circuit connections for the test are shown in Figure 12.12. This test is carried out by means of a number of steps. The flux density is changed in steps from the maximum value

$+B_{\max}$ down to some lower value, the iron specimen being passed through the remainder of the magnetisation cycle back to the flux density $+B_{\max}$. In Figure 12.12, R_1 is there to adjust galvanometer circuit; whereas, R_2 and R_4 are there to adjust the magnetising circuit. R_3 is a variable shunting resistor, connected across the magnetising winding by moving over the switch S_2 , thus reducing the current in this circuit from its maximum value down to any desired value—depending upon the value of R_3 .

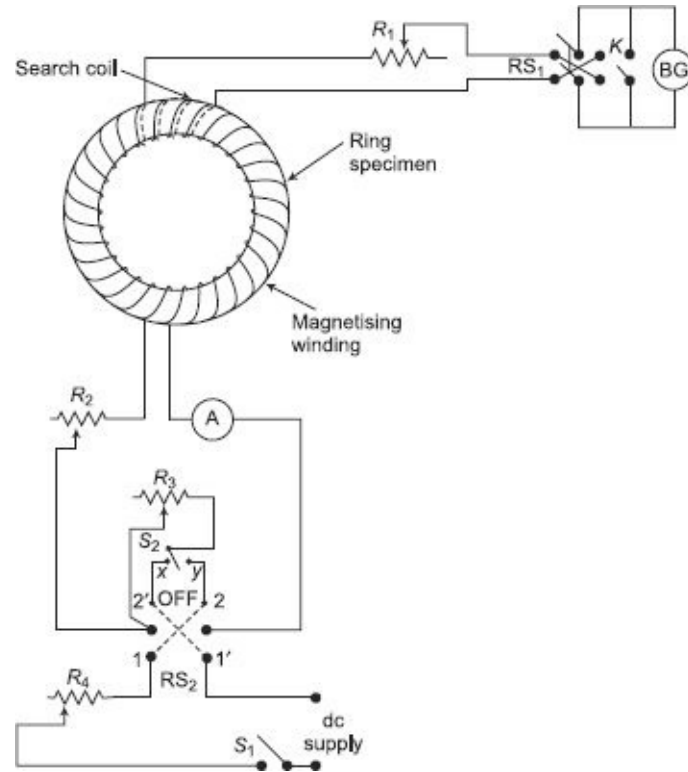

Figure 12.12 Circuit to measure hysteresis loop

The value of H_{\max} required to develop B_{\max} to be used during the test is taken from the previously obtained $B-H$ curve of the specimen. R_2 and R_4 are then varied so that the magnetising current is such that this value of H is obtained when S_2 is in the OFF position. Since $H = NI/l$. When the maximum value of the magnetising is reversed, to get a suitable deflection of the galvanometer, R_1 is adjusted. R_3 is adjusted to such a value that a suitable reduction of the current in the magnetising winding is obtained when this resistance is switched in the circuit. Switch RS_2 is then placed on contacts 1 1' and the short-circuiting key K opened. Since at this moment, maximum magnetising current is flowing, the magnetisation of the specimen corresponds to the point A on the loop shown in Figure 12.13.

In the next step, the switch S_2 is quickly thrown over from the OFF position to contact X , thus shunting the magnetising winding by R_3 and reducing the magnetising force to H_c (say). The corresponding reduction in flux density, $-\Delta B$, is obtained from the galvanometer throw, and hence the point C on the loop is obtained. The key K is now closed, and the switch RS_2 reversed on to contacts 2 2'. Switch S_2 is then opened and RS_2 moved back again to contacts 1 1'. In this procedure, the specimen undergoes a cycle of magnetisation and back to the point A and it is ready for the next step in the test. The section AD of the loop is found by continuation of this procedure.

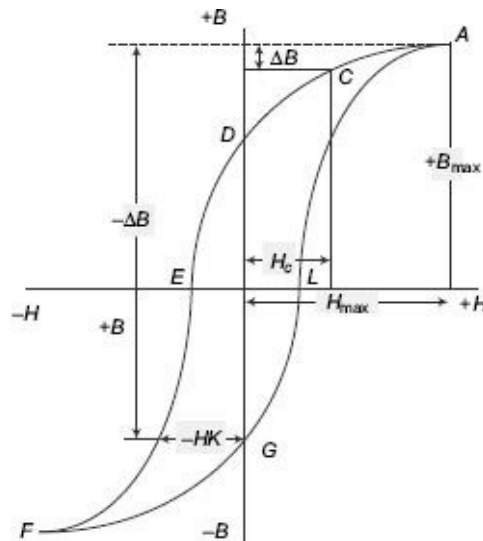

Figure 12.13 Hysteresis loop

To find out *DEF* section of the loop, with *K* closed and *S*₂ in the OFF position, *RS*₂ is placed on contacts 1 1'. Then throw *S*₂ on the contact *Y* position, open the key *K* and rapidly reverse *RS*₂ on to contacts 2 2'. From this throw, the change in flux $\Delta B'$ (Figure 12.13) may be obtained, since the switching operations described cause *H* to be changed from $+H_{\max}$ to $-Hk$ (say). To bring the magnetisation of the specimen back to the point *A*, close the key *K*, open *S*₂ and reverse *RS*₂ on to contacts 1 1'. By continuing this process, other points on the section *DEF* of the loop are found. The section *FGLA* of the loop may be obtained by drawing in reverse of *ADEF*, since the two halves are identical. By measuring the area of the hysteresis loop so obtained, by means of a planimeter, and expressing this area in *B-H* units of area, the hysteresis loss for the material may be obtained, since, hysteresis loss/cycle/m³ in joules = area of the loop in *B-H* units.

12.10

TESTING OF SPECIMENS IN THE FORM OF RODS OR BARS

It is obviously much easier to prepare a specimen in the form of a rod or bar than to prepare a ring specimen. However, if test methods described for ring specimens are employed to bar specimens, some difficulties and inaccuracies arise in testing. Bar specimens suffer from the disadvantage of “self-demagnetisation”. When a bar is magnetised electromagnetically, poles are produced at the ends, and these poles produce, inside the rod, a magnetising force from the north pole to the south which is in opposition to the applied magnetising force, thus rendering the true value of *H* acting on the bar a somewhat uncertain quantity. For accurate results, therefore, if the methods of measurement using a ballistic galvanometer are used, this demagnetising effect must be corrected for, or, since the effect is least when the ratio of diameter to length of the rod is small, the dimensions of the specimen should be chosen so that the effect is negligible. The demagnetising force due to this “end effect” is given by the expression

$$H_d = \frac{F}{\mu_0} B_f$$

where, B_f is the ferric induction, i.e. the flux density due to the magnetisation of the iron piece itself, and F is a constant which depends upon the relative dimension of the rod. For an ellipsoid or very long rod, the value of the coefficient F can be calculated from the expression

$$F = \left[\frac{1}{2k} \log_e \left(\frac{1+k}{1-k} \right) - 1 \right] \left(\frac{1}{k^2} - 1 \right)$$

where, $k = \sqrt{\left(1 - \frac{a^2}{b^2} \right)}$

a = minor axis of the ellipsoid

b = major axis of the ellipsoid

To obtain the true value of the magnetising force H acting on the bar specimen, H_d must be subtracted from the value of H calculated from the ampere-turns per metre length of the magnetising winding. It has been seen that the length-to-diameter ratio of the specimen must be of the order of 25 or more for to have a negligible influence upon the value of H .

On account of this demagnetising effect, the value of H is often measured by means of search coils wound on thin strips of glass and placed with the glass lying flat on the bar specimen. The flux density in the air at the surface of the specimen (which is same as H in the specimen) is measured by this means instead of relying upon calculated values and corrections.

12.11

PERMEAMETERS

There are various forms of “permeameters” that have been devised to avoid difficulties incurred to test straight specimens. Permeameters provide controllable field conditions to test bar specimens. They consist generally of a fixed steel frame to which straight samples can be fitted, but differ widely in the arrangement of magnetising and pick-up or search coils and in the means of guarding against leakage fluxes and mmf drops at the joints. All permeameters use return paths of large cross-section area in order to make the reluctance of the paths negligible. Most of the permeameters incorporate modifications of the bar and yoke arrangements first described by Hopkinson. The following discussion shall be limited only on a few of many forms of permeameters.

12.11.1 Hopkinson Permeameter (Bar-and-Yoke Method)

This method is used for the testing of bar specimens and the demagnetising effect is largely eliminated by the use of heavy-section yokes. A search coil is wound around the bar specimen at its centre, and the bar is then clamped between the two halves of a massive iron yoke, whose reluctance is small compared with that of the specimen, as shown in [Figure 12.14](#). The magnetising winding is fixed inside the yoke, as shown, the specimen fitting inside it.

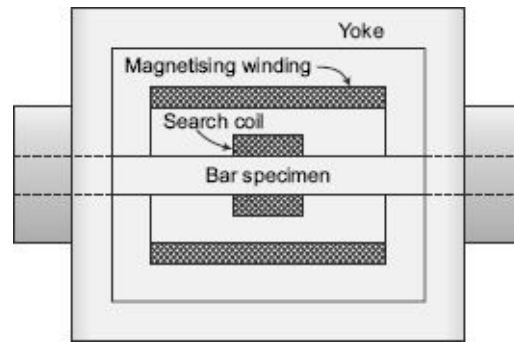

Figure 12.14 Bar and yoke method

Let, N = number of turns of the magnetising winding

I = current in the magnetising winding

l = length of specimen between two halves of the yoke

A = cross-section of the specimen

$\mu_s = \mu_{sr} \mu_0$ = permeability of the specimen when the magnetising current is I , μ_{sr} being the relative permeability of the specimen

R_y = reluctance of the yoke

R_j = reluctance of the two joints between bar specimen and yoke

Φ = flux in the magnetic circuit

Then,

Reluctance of the specimen, $R_s = l/\mu_s A$

So, flux $\Phi = \text{mmf}/\text{reluctance of magnetic circuit}$

$$= \frac{NI}{R_y + R_j + (l/\mu_s A)}$$

Flux density in the specimen, $B = \frac{\Phi}{A} = \frac{NI}{A(R_y + R_j + l/\mu_s A)}$

Magnetising force, $H = \frac{B}{\mu_s} = \frac{NI}{\mu_s A(R_y + R_j + l/\mu_s A)}$

Let, $m = \text{Reluctance of yoke and joints}/\text{Reluctance of the specimen}$

$$= \frac{R_y + R_j}{l/\mu_s A} = \frac{\mu_s A}{l} (R_y + R_j)$$

So,
$$H = \frac{NI}{l(1+m)}$$

The value of m is made small by keeping the reluctance of the yoke and the joints to a small value. This can be achieved by carefully fitting the specimen into the yoke so that air gap between the bar and yoke is negligible and making the yoke of large cross-section.

So if m is small,

$$H = \frac{NI}{l} (1-m) \text{ approx.}$$

which means that the actual value of H in the specimen differs from the value calculated from the magnetising ampere-turns and length of specimen by the amount mNI/l . The flux density may be measured by a ballistic galvanometer in the usual way.

12.11.2 Ewing Double Bar Permeameter

In this permeameter, two exactly similar bar specimens of the material under test are used, with two pairs of magnetising coils, one pair of the latter being exactly half the length of the other pair. The number of turns, per unit axial length, is same for both pairs of coil. Two yokes of annealed soft iron, with holes to receive the ends of the bar specimens—the fit being tight—are used. The arrangement of the bar and yoke is shown in [Figure 12.15](#).

The purpose of the arrangement is the elimination of the reluctance of yoke and joints. The tests are done, one with length of specimen = l and the other with length = $l/2$. It is assumed that for both positions, the reluctance of the yokes and joints is same for a given flux density.

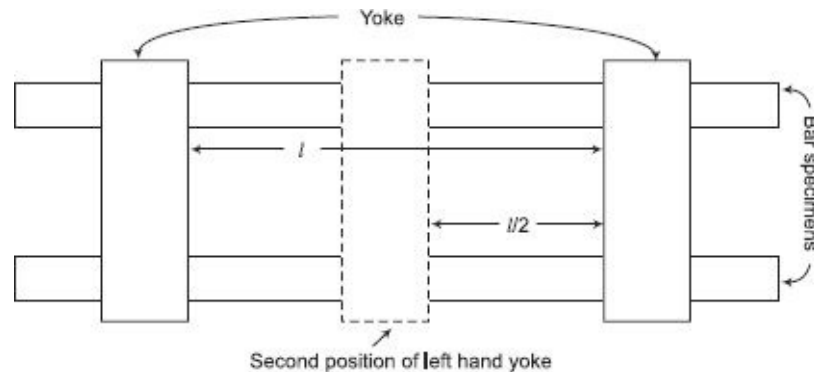

Figure 12.15 Ewing double bar method

Let, n = number of turns per unit length of magnetising coils

I_1 = current in the coils when the specimen length is l

I_2 = current in the coils when the specimen length is $l/2$

H_1 = apparent magnetising force when length is l

H_2 = apparent magnetising force when length is $l/2$

a = mmf required for the yokes and air gaps in each case

B = flux density in the specimen (the same in each case)

Then

$$H_1 = \frac{nI_1 l}{l} = nI_1$$

and $H_2 = \frac{n(l/2)I_2}{l/2} = nI_2$

If H be the true magnetising force in the iron for a flux density B ,

$$Hl = nI_1 l - a = H_1 l - a$$

and $Hl/2 = nI_2 l \cdot 2 - a = H_2 l/2 - a$

Hence, $a = l(H_2 - H_1)$

and $H = \frac{H_1 l - l(H_2 - H_1)}{l} = 2H_1 - H_2$

The flux density corresponding to this actual value of H is measured by means of search coils and ballistic galvanometer in ordinary way. The complete test is performed by first

obtaining and plotting a B - H curve for the specimen with a length of l —the apparent values of H being plotted. The specimens are then demagnetised, and a second B - H curve is obtained, and plotted, with a specimen length of $l/2$, the two curves being plotted on the same axis. The true B - H curve is obtained from these two, the true value of H , corresponding to any value of B , being obtained from the expression derived above.

The disadvantages of this method are

1. the reluctance of the yokes and joints is not exactly same for the two positions of the yoke,
2. the test requires two exactly similar bars, and
3. this test is somewhat lengthy.

12.11.3 Illiovi Permeameter

As shown in [Figure 12.16](#), it consists of a bar specimen clamped against a heavy yoke. The bar is wound with a magnetising winding and a search coil. A ballistic galvanometer BG_1 is connected across the search coil. A magnetic potentiometer is connected to a section XY of the bar specimen. The yoke is provided with compensating winding. It is connected in parallel with the magnetising winding across a reversing switch. When no magnetic potential drop is indicated by the magnetic potentiometer, the mmf of XY section is provided by the magnetising winding while for the remaining part of the specimen, the yoke and the joints, is provided by the compensating winding. This condition is achieved by adjusting the current in the main winding to the required test value and then adjusting the current in the compensating winding so that the ballistic galvanometer BG_2 shows no throw when the currents are reversed. Under this condition, there is a no-flux through the magnetic potentiometer and, therefore, no difference of magnetic potential exists between points X and Y . Thus, the magnetising force for length XY is given by $H = NI/l$, where, N is the number of turns in the magnetising winding, I is the current in the magnetising winding and l is length of XY .

The flux density in the specimen is found by noting the throw of BG_1 when the currents in magnetising winding and compensating winding are reversed simultaneously. The permeameter has the following disadvantages:

1. Since, there is lack of symmetry in the arrangement, the results obtained are not satisfactory.
2. This arrangement does not include a direct test of uniformity of magnetisation along the specimen.
3. Since compensating winding needs to be adjusted for each reading, the overall operation becomes complicated.
4. Some leakage between the yoke and specimen and the magnetic potentiometer may be affected by leakage flux which can introduce error in the test results.

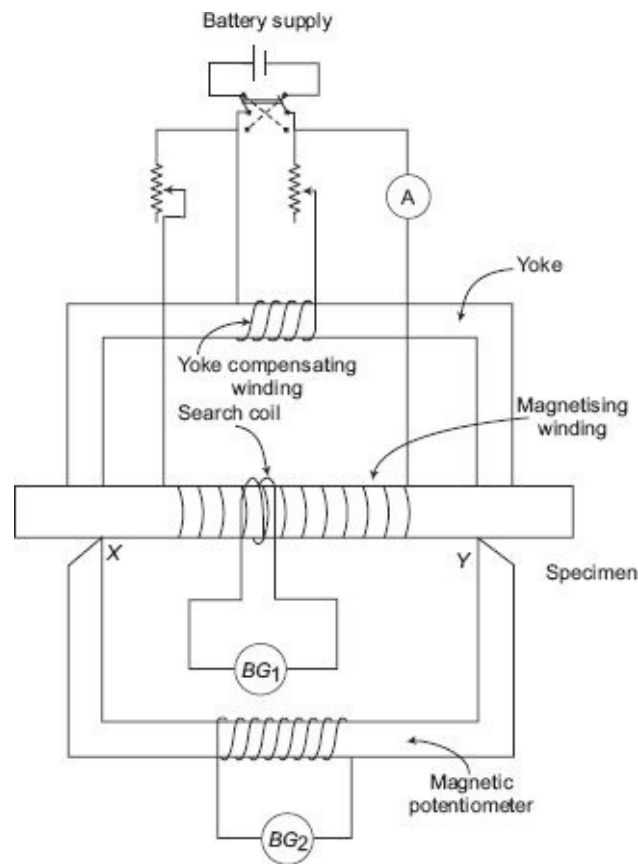

Figure 12.16 Illiovisci permeameter

12.11.4 Burrows Permeameter

This permeameter, which was first developed by CW Burrows, has been adopted as the standard apparatus for the testing of bar specimens. The effect of magnetic leakage at the joints between the yoke and specimen is eliminated in this permeameter by the use of a number of compensating windings which apply compensating mmfs at different parts of the magnetic circuit, these mmfs being just sufficient to drive the flux through the reluctance of the part upon which the coils are placed.

Figure 12.17 shows the arrangement of the magnetic circuit and coils. S_1 is the bar specimen under test and S_2 is a bar of identical dimensions to S_1 . These bars are surrounded by magnetising coils M_1 and M_2 . Magnetising windings are uniformly wound along the length of the bars. C_1, C_2, C_3 and C_4 are compensating coils for eliminating the leakage effects at the joints between the two bars and the massive yokes YY' into which the bars fit; c_x and c_y are two exactly similar search coils wound at the centres of the two bars, while d_1 and d_2 are two similar search coils wound in the positions shown, on the test bar, and each having exactly half the number of turns of the search coil c_x . Coils d_1 and d_2 are connected in series. Four coils C_1, C_2, C_3 and C_4 are also in series. The dimensions of the coils M_1 and M_2 are such that H in the specimen is around 10^4 times the current in the windings, the maximum value of H for which the apparatus is used being about 40,000 A/m. The dimensions of the bars are around 30 cm long and 1 cm in diameter. The coils C_1, C_2, C_3 and C_4 are supplied from a separate battery source, coil M_1 from another battery and M_2 from another. To perform the test, it is necessary, to ensure that for a given value of the current in M_1 , i.e. of H in the test bar, the flux threading through all four

search coils cx , cy , d_1 and d_2 is the same, the current in the compensating coils, and in M_2 , being adjusted until this condition is satisfied. If the flux threading coils d_1 and d_2 is the same as that of the threadings cx and cy , there can be no appreciable leakage of flux through the air in the joints. This means that the mmf for the joints is supplied by the compensating coils and that the mmf in coil M_1 is used up merely in driving the flux through the bar specimen S_1 inside it. Thus, H in the specimen is given by NI/l , where, N is the number of turns on M_1 , and I is current through M_1 and l is the length of the specimen in metres.

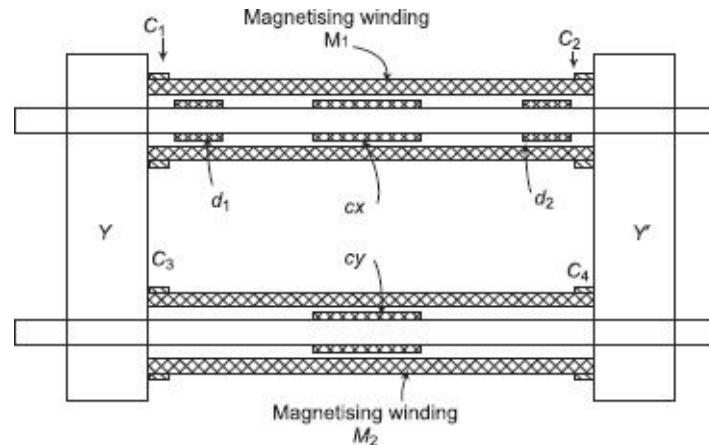

Figure 12.17 Magnetic circuit of Burrows double-bar and yoke permeameter

It may in some cases, be necessary to make corrections for the fact that the magnetising solenoids are not infinitely long, but such corrections are usually negligible. The procedure for getting equal flux threading in all four search coils is as follows.

As shown in [Figure 12.18](#), first, the specimen having been demagnetised, the current through the magnetising coil M_1 is set at the required testing level. Search coils cx and cy are then connected in series, but in opposition, to a ballistic galvanometer. The currents in M_1 and M_2 are then simultaneously reversed. A throw will be observed on the galvanometer. The current in M_2 is adjusted until no throw is obtained when two currents are reversed. Since search coils cx and cy have equal number of turns, this means that equal fluxes are now threading through them. Next, the search coil cx is connected in series with, but in opposition to, coils d_1 and d_2 and then to the ballistic galvanometer. The current in compensating coils C_1 , C_2 , C_3 and C_4 is then adjusted until no galvanometer deflection is obtained upon simultaneous reversal of the currents in these coils and in M_1 and M_2 . Then, since d_1 and d_2 together have the same number of turns as the coil cx , the flux threading all three coils is same. The flux density corresponding to the value of H in M_1 can be measured by connecting the coil cx alone to the ballistic galvanometer, and recording the throw when the currents in the two magnetising coils and compensating coils are simultaneously reversed. [Figure 12.18](#) gives a diagram of connection showing how the switching may be arranged for convenience in carrying out the test as described above.

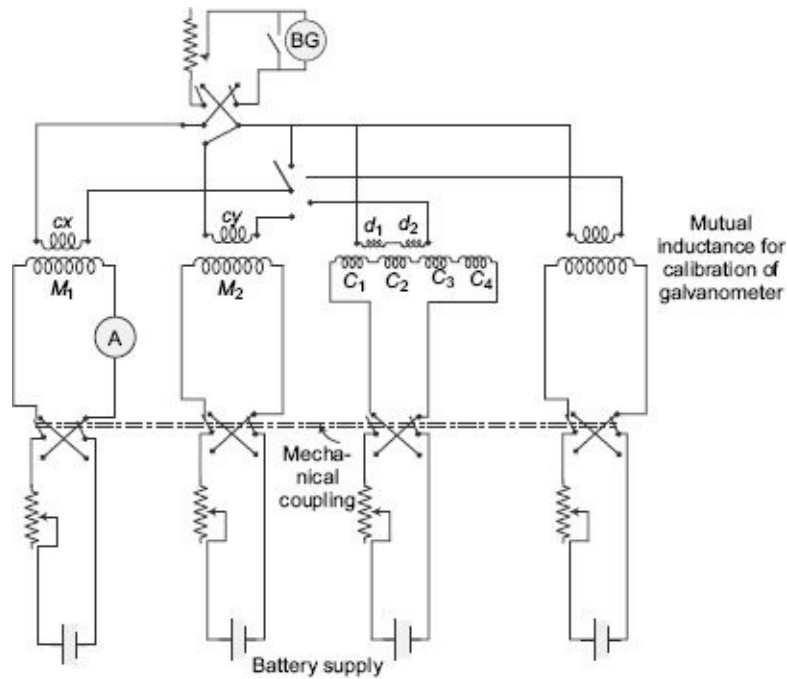

Figure 12.18 Circuit for Burrows double bar and yoke permeameter

12.12

MEASUREMENT OF MAGNETIC LEAKAGE

In dynamo-electric machinery, the magnetic flux per pole which crosses the air gap—the “useful flux”—is less than the flux in the body of the pole. This is due to the fact that some lines of force, called *leakage flux*, pass from the pole to the adjacent poles without crossing the air gap to the armature. The flux at the root of the pole is called *total flux* and the ratio of total flux to useful flux is the *leakage factor* of the pole.

Leakage factor can be measured by means of a fluxmeter. Here, galvanometer is not suitable on account of the high inductance of the field winding, which results in a slow rate of increase of flux when the voltage is switched on to the field winding. The total flux may be measured by winding two search coils on the yoke of the machine—in case of a dc machine with stationary field—one on either side of the pole as shown in Figure 12.19. As the yoke carries half of the total flux, these search coils must be connected in series so that the fluxmeter measure the flux embraced by both of them. The flux so measured will be the total flux. Another search coil, placed on the stationary armature in such a position that it embraces the useful flux from the pole, is then connected to the fluxmeter and the useful flux is measured. The leakage factor is obtained from these two measurements. It will usually be found that search coils of one turn will be most suitable, in which case the fluxmeter reading gives the flux directly.

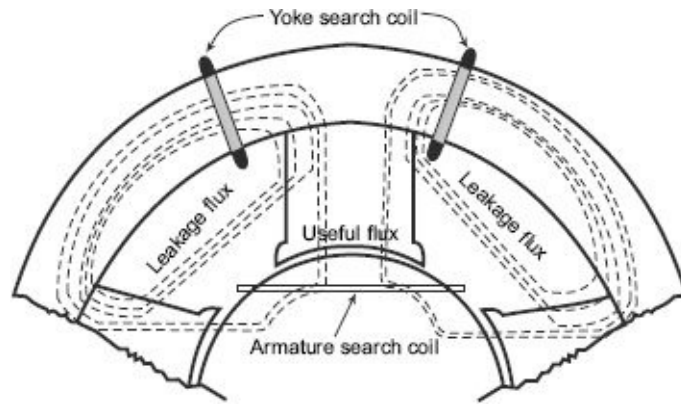

Figure 12.19 Measurement of magnetic leakage factor

12.13

MAGNETIC TESTING WITH ALTERNATING CURRENT

When iron is subjected to an alternating magnetic field, a power loss takes place due to hysteresis effects in the iron. Eddy currents which are set up in the iron further increase the power loss in the material. Although the hysteresis loss per cycle in iron may be determined from hysteresis loop obtained in dc tests, this loss may be somewhat different under the actual alternating magnetisation condition with which it will be working. Also, eddy current losses can only be measured by the use of alternating field. For these reasons, inspection tests upon sheet steel which is to be used in the manufacturing process of a transformer and other ac apparatus are very common ac tests. It is usually convenient to measure the hysteresis and eddy current loss in combined form, called *iron loss*.

Separation of Iron Losses

It is often sufficient, in acceptance tests of sheet material, to measure the total loss at the standard frequency and with maximum flux density of about 1 weber per square metre as the separation of the losses into their two components involves a rather more lengthy test.

Hysteresis loss can be expressed as

$$W_h = k \cdot f \cdot B_{\max}^{1.6}$$

where, W_h is the loss in watts per cubic metre of material, f being the supply frequency, B_{\max} the maximum flux density, and k a constant for any given material. This law holds good for values of B_{\max} between 0.1 and 1.2 Wb/m².

Eddy current loss, provided the sheets are sufficiently thin for *skin effect* to be negligible, is given by the expression

$$W_e = k' K_f^2 f^2 t^2 B_{\max}^{1.6}$$

where, W_e is the loss in watts per cubic metre, f is the frequency, t is the thickness of the sheet, and B_{\max} is the maximum flux density, and K_f is the form factor of the alternating flux and depends upon the shape of the wave.

Thus, if the form factor remains constant throughout the test and the maximum flux

density is kept constant, the total power loss being measured at different frequencies, may be written as

$$W_t = Mf + Nf^2$$

where, $M = KB^{1.6}_{\max}$

and $N = k' K_f^2 I^2 B^2_{\max}$

both M and N being constant for this test.

These constants may be determined, and the total loss thus split up into its two components, for any frequency, by plotting W/f against f as shown in Figure 12.20. Then $\frac{W_t}{f} = M + Nf$, so that the intercept on the vertical axis gives M , and N can be obtained from the slope of the graph. M is the hysteresis loss per cycle and the eddy-current loss for any frequency f_x is given by the intercept ED , as shown in Figure 12.21. Again, if the frequency and B_{\max} are kept constant and form factor is varied, the total loss being measured for various values of form factors is then

$$W_t = C + DK_f^2$$

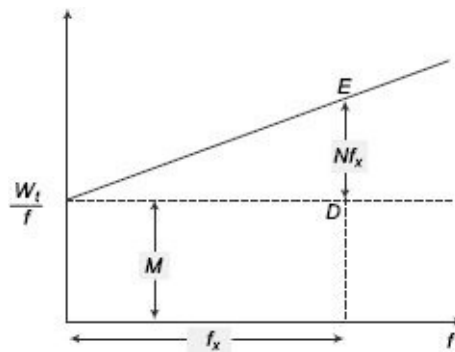

Figure 12.20 Separation of iron losses

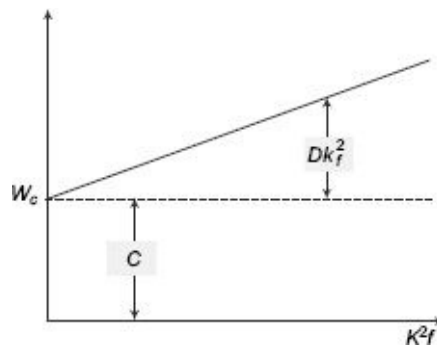

Figure 12.21 Separation of iron losses

If W_t is now plotted along the y-axis against the values of K_f^2 along the x-axis, the constants C and D may be obtained. The intercept upon the vertical axis gives C , and the slope of the line gives D .

The ac bridge or ac potentiometer methods are suitable for materials working at low flux densities. A number of bridge circuits are used where materials work at low flux densities and a small quantity of material is available. The test is to be performed at audio frequencies.

12.14.1 Maxwell's Bridge Method

Figure 12.22 shows the circuit diagram of the Maxwell bridge which is used to measure iron loss and permeability. R_1 , R_2 are fixed valued resistors and R_3 is a variable resistor. In series with R_3 a variable inductor L of resistance r is connected. It may be necessary to connect R_3 in series with the winding on the sample if resistance of the latter is small. The specimen, in ring form, is wound with a winding whose inductance is L_s and effective resistance R_s . This effective resistance contains an iron loss component. R_w is the actual resistance of the winding on the ring. G is a vibration galvanometer or telephone, and an ammetre. This supply from an ac source should be having a pure sinusoidal waveform. The balance of the bridge is obtained by adjusting L and R_3 .

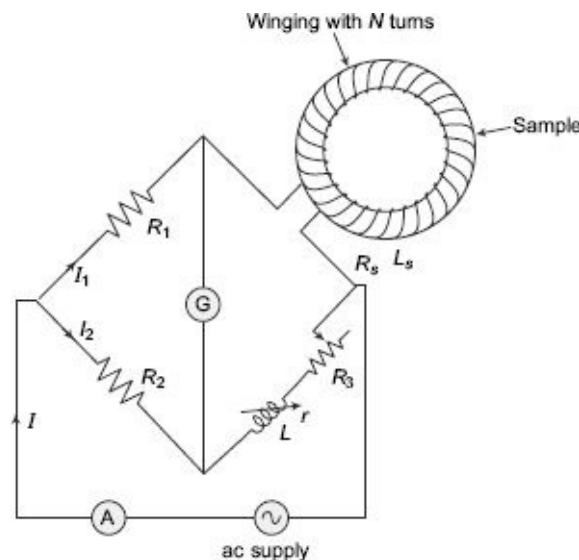

Figure 12.22 ac bridge for iron loss measurement

At balance,

$$I_1 R_1 = I_2 R_2$$

$$\text{and } I_1(R_s + j\omega L_s) = I_2[(r + R_3) + j\omega L]$$

where, $\omega = 2\pi \times \text{Frequency}$

Then, $\frac{I_1}{I_2} = \frac{R_2}{R_1}$

$$I_1 R_s = I_2 (r + R_3)$$

and $I_1 L_s = I_2 L$

From there,

$$\frac{R_2}{R_1} = \frac{r + R_3}{R_s}$$

or, $R_s = (r + R_3) \frac{R_1}{R_2}$

and $L_s = L \frac{R_1}{R_2}$

The iron loss in the sample is given by

$$R_s I_1^2 - R_w I_1^2$$

Now, the current, $I = I_1 + I_2$

Here, I_1 and I_2 are in phase.

Thus, $I = I_1 + \frac{R_1}{R_2} I_1 = I_1 \left(\frac{R_1 + R_2}{R_2} \right)$

or, $I_1 = \frac{R_2}{R_1 + R_2} \cdot I$

So, the iron loss,

$$W_i = I^2 \left(\frac{R_2}{R_1 + R_2} \right)^2 (R_s - R_w)$$

If N = number of turns on the specimen

l = length of mean circumference of the specimen (in metres)

a = cross section of specimen in square metres

μ_r = relative permeability of the specimen

Then the inductance is $L_s = \frac{N I_1}{l} \times \frac{N}{I_1} = \frac{N^2 a}{l} \mu_0 \mu_r$ henry

From which, μ_r can be calculated when L_s has been measured.

12.14.2 The ac Potentiometer Method

The circuit connection for measurement of iron loss with a potentiometer is shown in [Figure 12.23](#). The used potentiometer is of co-ordinate type. Here, the ring specimen carries two windings, the primary winding with N_1 turns and the secondary with N_2 turns, The primary winding is supplied from an alternator through a regulating transformer. The alternator is also supplying to two potentiometer slide-wire circuits. The primary winding circuit contains a regulating resistor and a standard resistor R is connected in series with it. This resistor is introduced in the circuit to sense the current in the primary winding by measuring the potential drop across it. A vibration galvanometer G is used in the test. At first, the potentiometer is standardised. The supply is fed to the primary winding of the specimen, as a result, the voltage E_2 is induced in the secondary winding.

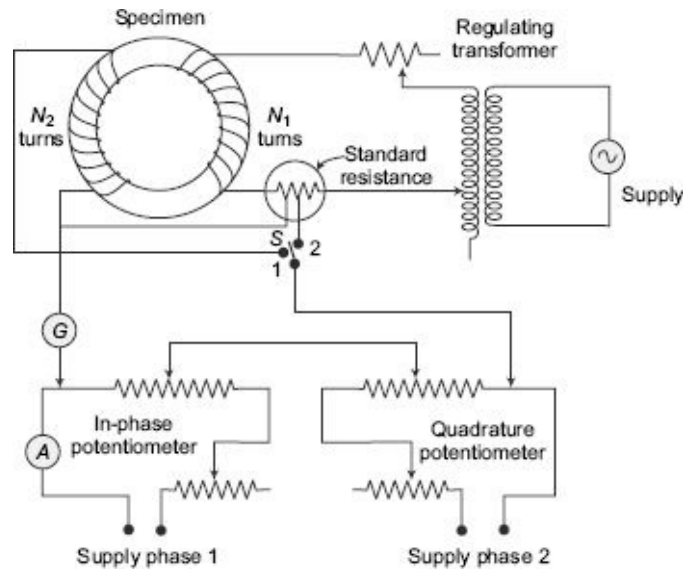

Figure 12.23 Iron loss measurement by ac potentiometer

$$\text{where, } E_2^2 = 4K_f f \Phi^{\max} N_2 = 4K_f f B_{\max} A_s N_2$$

In the above expression, K_f = Form factor = 1.11 for sinusoidal supply, f = Supply frequency, B_{\max} = maximum flux density, A_s = Cross-section area of the specimen, N_2 = Number of turns in the secondary winding.

And maximum flux density,

$$B_{\max} = \frac{E_2}{4K_f f A_s N_2} = \frac{E_2}{4.44 f A_s N_2}$$

The voltage E_2 is measured by placing the switch S on the contact x , setting the quadrature potentiometer at zero and adjusting the in-phase potentiometer till balance is obtained. The setting of the in-phase potentiometer indicates the value of E_2 directly.

The switch is then placed to contact y . At this position, the potential drop in the standard resistor R is matched against the in-phase and quadrature potentiometers. These two potentiometers are adjusted to achieve the balanced condition. The reading of the in-phase potentiometer gives the value $I_e R$ where I_e is the loss component of the current in the primary winding:

$$I_e = \text{reading of in-phase potentiometer}/R$$

The reading of the quadrature potentiometer indicates the value of $I_m R$, where, I_m is the magnetising component of the current in the primary winding.

$$I_m = \text{reading of quadrature potentiometer}/R$$

$$\text{The iron loss} = I_e E_2 N_1 / N_2$$

This method is suitable for ac magnetic testing at low flux densities, since magnetising and iron-loss components of exciting current are measured separately

Magnetic shielding is an important issue to prevent magnetic field from interfering with electrical devices. Magnetic shielding is a process of reducing the coupling of a magnetic field between two locations. A number of materials are used for this purpose including sheet metal, metal mesh, ionised gas, or plasma. Unlike electricity, magnetic fields cannot be blocked or insulated. As a result, magnetic shielding is very much essential to stop malfunctioning of electrical and electronics devices and equipments if they are put in service in such an environment where a chance of magnetic interference is prevailing. According to Maxwell's equations, $\text{div } B = 0$, which means that there are no magnetic monopoles. As a result, magnetic field lines must terminate on the opposite pole. There is no way to block these field lines; nature finds a path to return the magnetic field lines back to an opposite pole. Even if a nonmagnetic object—for example, glass—is placed between two opposite poles of a magnet, the magnetic field will not change.

The main concept of magnetic shielding is to re-route the magnetic field lines around the object or device under threat of magnetic interference. This can be achieved by surrounding the device with a magnetic material with higher permeability than that of the device inside under threat. By doing so, the magnetic field lines tend to find an easier path along the shielding material, thus avoiding the object inside. This technique merely redirects the magnetic field lines to a material having high permeability, instead of stopping or blocking magnetic field lines.

It is important that materials used in magnetic shielding purpose should have high permeability, but it is also important that they themselves should not develop permanent magnetisation. Keeping these points in consideration, the most effective magnetic shielding material available is mu-metal, an alloy containing 77% nickel, 16% iron, 5% copper, and 2% chromium, which is then annealed in a hydrogen atmosphere to increase its permeability. Mu-metal is extremely expensive, that's why other alloys with similar compositions are sold for magnetic shielding, usually in rolls of foil.

Important Areas for Magnetic Shielding

Magnetic shielding is essentially employed in hospitals, where devices such as Magnetic Resonance Imaging (MRI) equipment generate powerful magnetic flux which can interfere with surrounding instruments or metres.

Magnetic shielding rooms are also used in electron beam exposure rooms where semiconductors are made, or in research facilities using magnetic flux.

Applications of magnetic shielding are common in home theatre systems. Speaker magnets can distort a Cathode Ray Tube (CRT) television picture when placed close to the set, so speakers intended for that purpose use magnetic shielding.

Magnetic shielding is also used to counter similar distortion on computer monitors.

Magnetic shielding is quite essential in laboratories and factories where high-voltage tests or operations are performed. Normally, shielding nets are preferred for this purpose.

EXERCISE

Objective-type Questions

1. Which of the following measures the magnetic flux density?
 - (a) Ballistic galvanometer
 - (b) Grassot fluxmeter
 - (c) Permeameter
 - (d) All of the above
2. When a magnetic material is subjected to alternating field, loss of power occurs owing to
 - (a) hysteresis only
 - (b) eddy current only
 - (c) both hysteresis and eddy currents
 - (d) none of the above
3. The area of the hysteresis loop in magnetic specimen indicates
 - (a) hysteresis and eddy current loss
 - (b) hysteresis loss
 - (c) hysteresis loss per unit volume
 - (d) hysteresis loss per unit volume per cycle of frequency
4. The ratio of total flux to the useful flux in a magnetic circuit is called
 - (a) form factor
 - (b) leakage factor
 - (c) utility factor
 - (d) dispersion factor
5. Maxwell's bridge method is used to measure
 - (a) iron loss and permeability
 - (b) copper loss
 - (c) copper loss and iron loss
 - (d) none of these

Answers				
1. (b)	2. (c)	3. (d)	4. (d)	5. (a)

Short-answer Questions

1. Why are magnetic measurements not as accurate as other types of measurements in electrical engineering?
2. Why are ring specimens preferred over rods or bars for magnetic testing?
3. Why is the fluxmeter employed to measure leakage factor in electric machinery rather than ballistic galvanometer?
4. What are the components of power loss that occur in ferromagnetic materials when subjected to alternating magnetic fields?
5. What are the methods used for measuring iron losses?

Long-answer Questions

1. What are the different types of magnetic measurement? How is ballistic galvanometer used in magnetic measurement? Explain the working principle of a ballistic galvanometer.
2. Explain how a ballistic galvanometer is used to measure flux changes occurring in magnetic circuits and indicate the essential conditions to be satisfied by the ballistic galvanometer chosen for this purpose.
3. How is the magnetic flux measured by a ballistic galvanometer? What are the different methods to calibrate a ballistic galvanometer?

4. What are ballistic tests used for testing of magnetic materials? How is flux density determined in the ring type specimen of magnetic material?
5. Explain the working principle of a fluxmeter with the help of a neat diagram.
6. Give the advantages and disadvantages of ring and bar specimens used in magnetic testing of materials.
7. Briefly describe a method for measurement of $B-H$ curve of a magnetic substance of bar form.
8. With the help of a circuit diagram, describe the step-by-step procedure to draw the complete $B-H$ loop of a ring specimen.
9. Describe the procedure to determine hysteresis loop by the method of reversal, and suggest precautions to be followed.
10. Discuss the principle and advantage of a permeameter for the determination of $B-H$ curve of a sample.
11. How is the bar-and-yoke method employed to measure the magnetising force of a specimen?
12. Describe the construction and working of a Burrows permeameter bringing its relative advantages over other types for testing a bar specimen.
13. What are iron losses? How do they vary with frequency? Explain the procedure for separation of iron losses.
14. Explain the ac potentiometer method of determination of iron losses.
15. Write short notes on the following:
 - (a) Flux measurement
 - (b) Ewing double bar permeameter
 - (c) Illiovisci permeameter
 - (d) Maxwell's bridge method for iron loss measurement

13.1

INTRODUCTION

Signal generators provide a variety of waveforms for testing of electronic circuits at low power levels. There are various types of signal generators, but the following characteristics are common to all types:

1. Always a stable generator with desired frequency signals should be generated.
2. Generated signal amplitude should be regulated over a wide range from very small to relatively large level.
3. Generated signal should be free from any distortions.

There are many variations of the above requirements, especially for specialised signal generators such as function generators, pulse generators and pulse frequency generators. Sine wave generators, both in audio and radio frequency ranges are called oscillators. Although, the terminology is not universal, the term *oscillator* is generally used for an instrument that provides only a sinusoidal output signal. The term *function generator* is applied to an instrument that provides several output waveforms, including sine wave, square wave, triangular wave and pulse trains as well as amplitude modulation of the output signal.

13.2

OSCILLATORS

Oscillator is the basic element of ac signal sources and generates sinusoidal signals of known frequency and amplitude. The main applications of oscillators are as sinusoidal waveform sources in electronic measurement work. Oscillators can generate a wide range of frequencies (few Hz to many GHz) as per the requirement of the application. Although an oscillator can be considered as generating sinusoidal signal, it is to be noted that it merely acts as an energy converter. It converts a dc source of supply to alternating current of desired frequency.

Oscillators are generally an amplifier with positive feedback. An oscillator has a gain equal to or slightly greater than unity. In the feedback path of the oscillator, capacitor, inductor or both are used as reactive components. In addition to these reactive components, an operational amplifier or bipolar transistor is used as amplifying device. No external ac input is required to cause the oscillator to work as the dc supply energy is converted by the oscillator into ac energy.

Oscillators may be classified in a number of ways. Here they are classified on three

bases: (a) the design principle used, (b) the frequency range over which they are used, and (c) the nature of generated signals.

1. Classification According to Design Principle

(a) Positive feedback oscillators (b) Negative feedback oscillators

2. Classification According to Frequency Band of the Signals

- (a) Audio Frequency (AF) oscillators—frequency range is 20 Hz to 20 kHz
- (b) Radio Frequency (RF) oscillators—frequency range is 20 kHz to 30 MHz
- (c) Video Frequency oscillators—frequency range is dc to 5 MHz
- (d) High Frequency (HF) oscillators—frequency range is 1.5 MHz to 30 MHz
- (e) Very High Frequency (VHF) oscillators—frequency range is 30 MHz to 300 MHz

3. Classification According to Types of Generated Signals

(a) Sinusoidal Oscillators These are known as harmonic oscillators and are generally *LC* tuned-feedback or *RC* tuned-feedback type oscillator that generates a sinusoidal waveform which is of constant amplitude and frequency.

(b) Non-sinusoidal Oscillators These are known as relaxation oscillators and generate complex non-sinusoidal waveforms that changes very quickly from one condition of stability to another such as square-wave, triangular-wave or sawtooth-wave-type waveforms.

13.2.1 Feedback Circuit Employed in Oscillators

It is the use of positive feedback that results in a feedback amplifier having closed-loop gain A_f greater than unity and satisfies the phase condition.

In a system assuming, V_{in} and V_{out} as the input and output voltages respectively. Without feedback or open-loop gain,

$$A_v = \frac{V_{out}}{V_{in}}$$

$$\therefore V_{out} = A_v V_{in}$$

Taking the forward path gain of the system as A and β as feedback factor

With feedback, the output voltage of the system,

$$V_{out} = A_v(V_{in} + \beta V_{out})$$

$$\therefore V_{out} = A_v V_{in} + A_v \beta V_{out}$$

$$\therefore V_{out}(1 - A_v \beta) = A_v V_{in}$$

$$A_f = \frac{V_{out}}{V_{in}} = \frac{A_v}{1 - A_v \beta}$$

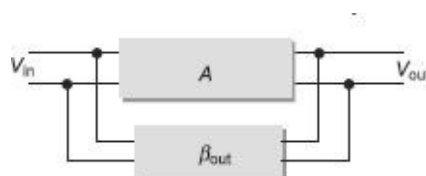

Figure 13.1 Basic feedback circuit employed in oscillators

Oscillators generate a continuous voltage output waveform at a required frequency with the values of the inductors, capacitors or resistors forming a frequency selective LC resonant (or tank) feedback network. The oscillator frequency is regulated using a tuned or resonant inductive/capacitive circuit with the resulting output frequency being known as the oscillation frequency. So, the feedback path of the oscillator is made reactive. The phase angle of the feedback will vary as a function of frequency and this is called *phase shift*. Certain conditions are required to fulfill for sustained oscillations and these conditions are that (a) the loop gain of the circuit must be equal to or greater than unity, and (b) the phase shift around the circuit must be zero. These two conditions for sustained oscillations are called *Barkhausen criteria*.

13.2.2 Resonance

If a constant voltage with varying frequency is impressed to a circuit consisting of an inductor, capacitor and resistor, then the reactance of both the capacitor-resistor (RC) and inductor-resistor (RL) paths are to change both in amplitude and in phase of the output signal as compared to the input signal. At high frequencies the reactance of a capacitor is very low and it acts as a short circuit while the reactance of the inductor is high and it acts as an open circuit. At low frequencies, the reverse is true, meaning the reactance of the capacitor acts as an open circuit and the reactance of the inductor acts as a short circuit. Between these two boundaries, the combination of the inductor and capacitor produces a tuned or resonant circuit that has a resonant frequency (f_r) in which the capacitive and inductive reactances are equal and cancel out each other, leaving only the resistance of the circuit to oppose the flow of current and as a result of that, there is no phase shift as the current is in phase with the voltage. Based on this concept subsequent sections of the chapter are explained.

13.2.3 Basic LC Oscillatory Circuit

As shown in [Figure 13.2](#), the circuit consists of an inductive coil L and a capacitor C . The capacitor stores energy in the form of an electrostatic field and which produces a potential or *static voltage* across it, while the inductive coil stores its energy in the form of a magnetic field. The capacitor is charged up to the dc supply voltage V by putting the switch in the position A . When the capacitor is fully charged, the switch is thrown to the position B and the charged capacitor is now connected in parallel across the inductive coil so the capacitor begins to discharge itself through the coil. The voltage across C starts falling as the coil. The voltage across C starts falling as the current through the coil begins to rise. This rising current sets up an electromagnetic field around the coil and when C is completely discharged, the energy that was originally stored in the capacitor C as an electrostatic field is now stored in the inductive coil L as an electromagnetic field around the coil windings. As there is now no external voltage in the circuit to maintain the current within the coil, it starts to fall as the electromagnetic field begins to collapse. A back emf is induced in the coil ($e = -Ldi/dt$) keeping the current flowing in the original direction. This current now charges the capacitor C with the opposite polarity to its original charge. C continues to charge until the current has fallen to zero and the electromagnetic field of the coil has collapsed completely. The energy originally introduced into the circuit through

the switch has been returned to the capacitor which again has an electrostatic potential across it, although it is now of the opposite polarity. The capacitor now starts to discharge again back through the coil and the whole process is repeated, with the polarities changed and continues as the energy is passed back and forth producing an ac type sinusoidal voltage and current waveform.

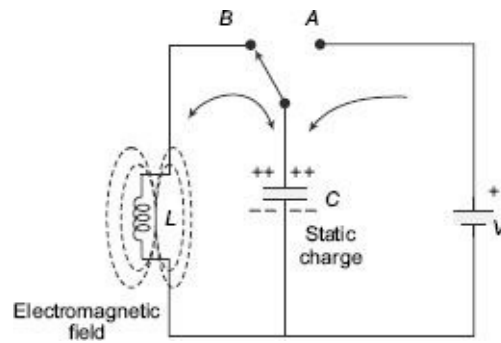

Figure 13.2 Basic LC oscillator circuit

This oscillatory action of transferring energy from the capacitor C to the inductor, L and vice versa, would continue indefinitely if there is no loss of energy in the circuit. But, energy is lost in the resistance of the inductor coil, in the dielectric of the capacitor, and in radiation from the circuit; so the oscillation steadily decreases until it dies away completely. Then in a practical LC circuit, the amplitude of the oscillatory voltage decreases at each half cycle of oscillation and will eventually die away to zero. The oscillations are then said to be damped. The quality factor of the circuit sets the amount of damping. In [Figure 13.3](#), damped oscillations are shown in both the cases, with small R and with large R .

The frequency of the oscillatory voltage depends upon the value of the inductance and capacitance in the LC circuit. We know when *resonance* has to occur, both the capacitive X_C and inductive X_L reactances must be equal and opposite to cancel out each other. As a result, the resistance in the circuit remains to oppose the flow of current. Then the frequency at which this will happen is given as

$$X_L = 2\pi fL$$

and
$$X_C = \frac{1}{2\pi fC}$$

At resonance, $X_L = X_C$

$$\therefore 2\pi fL = \frac{1}{2\pi fC}$$

$$f^2 = \frac{1}{(2\pi)^2 LC}$$

Resonant frequency in a tuned LC circuit, the output frequency, $f_r = \frac{1}{2\pi\sqrt{LC}}$

To maintain the oscillations keeping the amplitude at a constant level, in an LC circuit, it is required to replace the energy lost in each oscillation. The amount of energy replaced must be equal to that lost during each cycle. Alternatively, if the amount of energy replaced is too small, the amplitude would decrease to zero over time. The simplest way of replacing this energy is to take part of the output from the LC circuit, amplify it and then feed it back into the LC circuit again and this can be achieved using a voltage amplifier. To produce a constant oscillation, the level of the energy fed back to the LC network must be

accurately controlled. Then there must be some form of automatic amplitude or gain control when the amplitude tries to vary from a reference voltage either up or down. To maintain a stable oscillation the overall gain of the circuit must be equal to 1 or unity. Any less and the oscillations will not start or die away to zero, any more the oscillations will occur but the amplitude will become clipped by the supply rails causing distortion. A circuit containing this feature is considered in the next section.

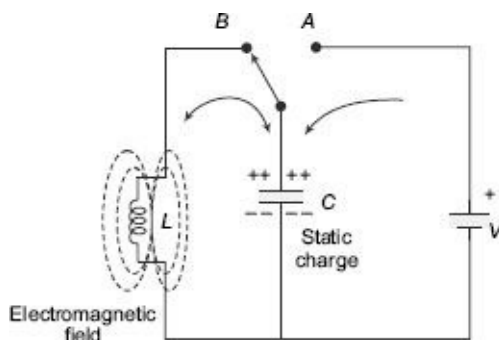

Figure 13.3 Damped oscillations

13.2.4 Basic Transistor LC Oscillator Circuit

A BJT is used as the oscillator amplifier and the tuned LC circuit acts as the collector load as shown in Figure 13.4. A second coil L_2 is connected between the base and emitter. Electromagnetic field of L_2 is mutually coupled with that of the coil L . Mutual inductance exists between two circuits. The changing current in one circuit induces by electromagnetic induction a potential in the other due to transformer action. So as the oscillations take place in the tuned circuit, electromagnetic energy is transferred from the coil L to the coil L_2 and a voltage of the same frequency as that in the tuned circuit is applied between the base and emitter of the transistor. In this way, the necessary automatic feedback voltage is obtained. The amount of feedback can be varied by changing the coupling between coils L and L_2 . When the circuit is oscillating, its impedance is resistive and the collector and base voltages are 180° out of phase. In order to maintain oscillations, the voltage applied to the tuned circuit must be in-phase with the oscillations occurring in the tuned circuit. So, it is necessary to introduce an additional 180° phase shift into the feedback path between the collector and base. This is done by winding the coil of L_2 in the correct direction relative to the coil L giving us the correct amplitude and phase relationships for the oscillator circuit or by introducing a phase shift network between the output and input of the amplifier.

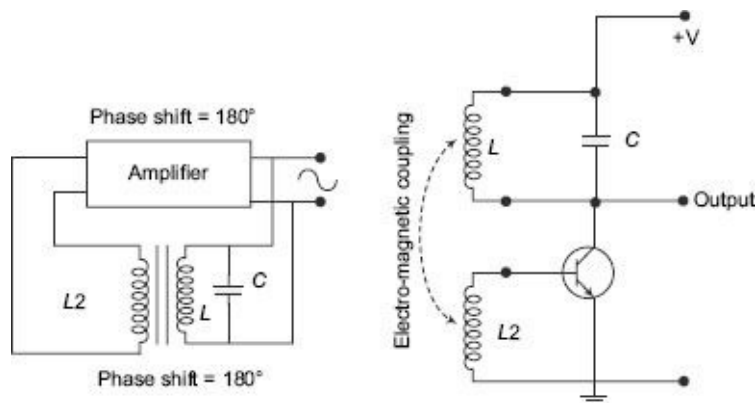

Figure 13.4 Basic transistor LC oscillator

LC oscillators are actually sinusoidal oscillators or harmonic oscillators that can generate high-frequency sine waves for use in Radio Frequency (RF) Type applications with the transistor amplifier being a BJT or FET. There are different ways to construct LC filter networks and amplifiers. As a result, harmonic oscillators come in different forms and the most common forms are Hartley LC oscillator, Colpitts LC oscillator, Armstrong oscillator, Clapp oscillator, etc.

13.2.5 Oscillator Summary

A few basic requirements for an oscillatory circuit are given as follows:

1. The circuit should contain a reactive or frequency dependent component—either an Inductor (L) or a Capacitor (C) and a dc supply voltage.
2. Overall gain of the amplifier circuit must be at least unity.
3. Self-regenerative or positive feedback results oscillations.
4. Oscillations of the circuit become damped due to circuit losses.
5. To overcome these circuit losses, voltage amplification is necessary.
6. Desired oscillations can be maintained by using some part of the output voltage as feedback to the tuned circuit that is of the correct amplitude and in-phase (0°).
7. To keep the output signal in phase with the input, the overall phase shift of the circuit must be zero.

13.3

HARTLEY OSCILLATOR

The basic LC oscillator circuit does not have the option of controlling the amplitude of the oscillations. A weak electromagnetic coupling between L and L_2 results in insufficient feedback and the oscillations would eventually die away to zero. Similarly, a strong feedback causes the oscillations to increase in amplitude until they are limited by the circuit conditions producing distortion. It is possible to feed back exactly the right amount of voltage for constant amplitude oscillations. If the feedback is more than what is necessary, the amplitude of the oscillations can be controlled by biasing the amplifier in such a way that if the oscillations increase in amplitude, the bias is increased and the gain of the amplifier is reduced. If the amplitude of the oscillations decreases, the bias decreases and the gain of the amplifier increases, thus, increasing the feedback. This is the method to keep oscillations constant and it is known as *automatic base bias*. Efficient oscillator can be implemented by employing a class-B or even class-C bias as the collector current flows during only part of the cycle and the quiescent collector current is very small. Then this self-tuning base oscillator circuit forms the basic configuration for the Hartley oscillator circuit.

In the Hartley oscillator, the tuned LC circuit is connected between the collector and the base of the transistor amplifier and as far as the oscillatory voltage is concerned, the emitter is connected to a tapping point on the tuned circuit coil. A Hartley oscillator can be

implemented from any configuration that uses either a single-tapped coil or a pair of series-connected coils in parallel with a single capacitor.

13.3.1 Basic Hartley Oscillator Circuit

Figure 13.5 shows the basic Hartley oscillator circuit. During oscillation, the voltage at the point X (collector), relative to the point Y (emitter), is 180° out-of-phase with the voltage at the point Z (base) relative to the point Y . At the frequency of oscillation, the impedance of the collector load is resistive and an increase in base voltage causes a decrease in the collector voltage. Then there is a 180° phase change in the voltage between the base and collector and this along with the original 180° phase shift in the feedback loop provides the correct phase relationship of positive feedback for oscillations to be maintained. The position of tapping point of the inductor sets the amount of feedback. If it is moved nearer to the collector, the amount of feedback is increased, but the output taken between the collector and ground is reduced and vice versa. Resistors R_1 and R_2 are there for the usual stabilising dc bias for the transistor in the normal manner while the capacitors act as dc-blocking capacitors. In this circuit, the dc collector current flows through a part of the coil and for this reason, the circuit is said to be series-fed with the frequency of oscillation of the Hartley oscillator being given as

$$f = \frac{1}{2\pi\sqrt{LC}}$$

where, $L = L_1 + L_2$.

Note: L is the total inductance if two separate coils are used.

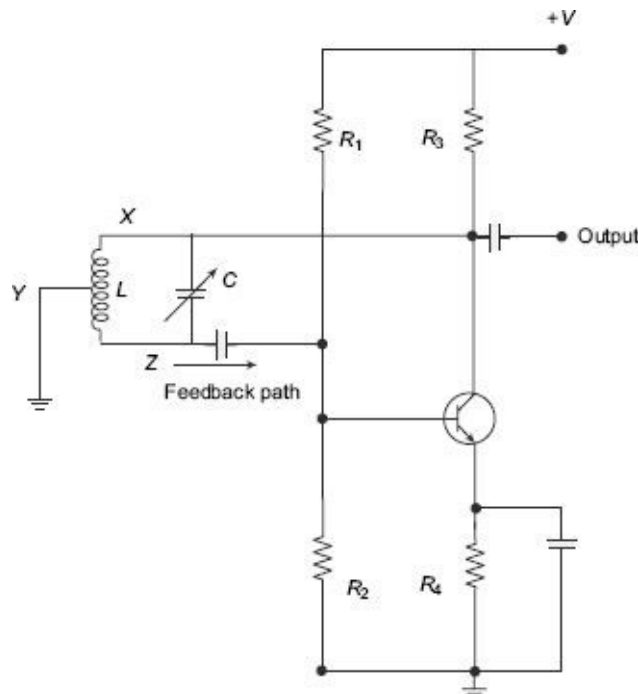

Figure 13.5 Basic Hartley oscillator

The frequency of oscillations can be adjusted by varying the tuning capacitor C or by varying the tap position of the inductive coil, giving an output over a wide range of frequencies making it very easy to tune. In the series-fed Hartley oscillator, it is also possible to connect the tuned tank circuit across the amplifier as a shunt-fed oscillator discussed as follows.

13.3.2 Shunt-fed Hartley Oscillator Circuit

As shown in Figure 13.6, in the shunt-fed Hartley oscillator, both the ac and dc components of the collector current have separate paths around the circuit. Here, a very small amount of power is wasted in the tuned circuit. Since the dc component is blocked by the capacitor C_2 , no dc component flows through the inductive coil, L . The Radio Frequency Coil (RFC) L_2 is an RF choke which offers a high reactance at the frequency of oscillations so that most of the RF current is applied to the LC tuning tank circuit via the capacitor, C_2 as the dc component passes through L_2 to the power supply. A resistor could be used in place of the RFC coil but the efficiency would be less.

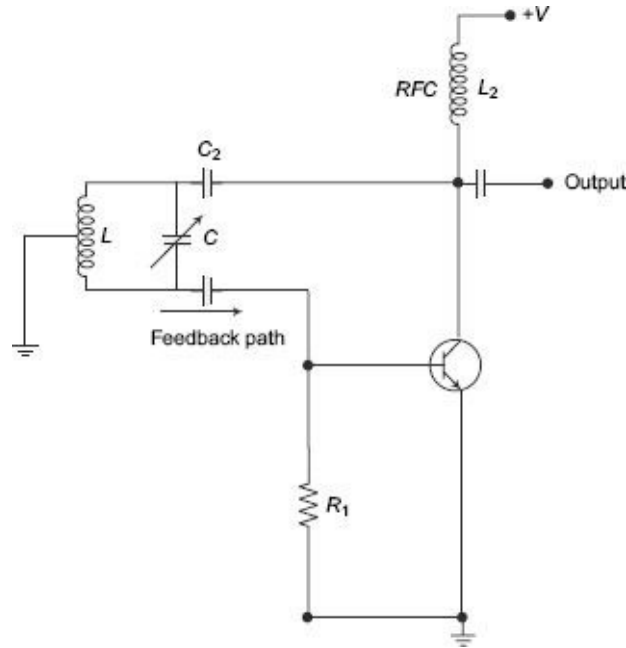

Figure 13.6 Shunt-fed Hartley oscillator

Example 13.1

One Hartley oscillator circuit has two inductors of 0.5 mH and each is tuned to resonate with a capacitor which can be varied from 100 pF to 500 pF. Determine the upper and lower frequencies of oscillation and the oscillator bandwidth.

Solution The circuit consists of two inductive coils in series.

The total inductance is given as:

$$L_T = L_1 + L_2 = 0.5 + 0.5 = 1 \text{ mH}$$

$$\text{Upper frequency, } f_H = \frac{1}{2\pi\sqrt{1 \text{ mH} \times 100 \text{ pF}}} = 503 \text{ kHz}$$

$$\text{Lower frequency, } f_L = \frac{1}{2\pi\sqrt{1 \text{ mH} \times 500 \text{ pF}}} = 225 \text{ kHz}$$

$$\text{Oscillator bandwidth} = f_H - f_L = 503 - 225 = 278 \text{ kHz}$$

13.4

COLPITTS OSCILLATORS

The Colpitts oscillator is somewhat opposite to the Hartley oscillator as the centre tapping is made from capacitive voltage divider network instead of tapped inductive coil as shown in Figure 13.7. Similar to the Hartley oscillator, the tuned tank circuit consists of an LC resonance circuit connected between the collector and base of the transistor amplifier.

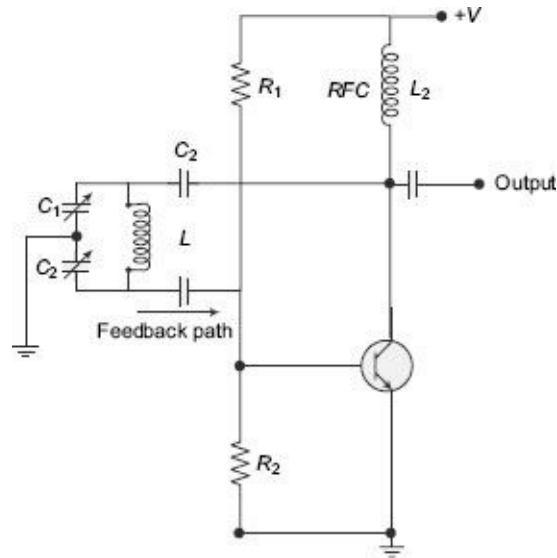

Figure 13.7 Basic Colpitts oscillator circuit

The emitter of the transistor amplifier is connected to the junction of capacitors C_1 and C_2 which are connected in series with the required external phase shift obtained in a similar manner to that in the Hartley oscillator. The amount of feedback is controlled by the ratio of C_1 and C_2 which are generally ganged together to provide a constant amount of feedback. Once again, the frequency of oscillations for a Colpitts oscillator is determined by the resonant frequency of the LC tank circuit and is given as

$$f = \frac{1}{2\pi\sqrt{LC_T}}$$

where C_T is the capacitance of C_1 and C_2 connected in series and is given as.

$$\frac{1}{C_T} = \frac{1}{C_1} + \frac{1}{C_2} \quad \text{or} \quad C_T = \frac{C_1 \times C_2}{C_1 + C_2}$$

A common emitter-amplifier configuration is employed here, with the output signal 180° out of phase with respect to the input signal. The two capacitors are connected together in series but in parallel with the inductive coil resulting in overall phase shift of the circuit being zero. Resistors R_1 and R_2 are used for the usual stabilising dc bias for the transistor in the normal manner while the capacitor acts as dc-blocking capacitors.

Example 13.2

One Colpitts oscillator circuit has two capacitors of 10 pF and 100 pF respectively connected in parallel with an inductor of 10 mH. Determine the frequency of oscillations of the circuit.

Solution The circuit consists of two capacitors in series.

So, the total capacitance is given as

$$C_T = \frac{C_1 \times C_2}{C_1 + C_2} = \frac{10 \text{ pF} \times 100 \text{ pF}}{10 \text{ pF} + 100 \text{ pF}} = 9.1 \text{ pF}$$

If the inductor is of 10 mH then the frequency of oscillation is

$$f = \frac{1}{2\pi\sqrt{LC_T}} = \frac{1}{6.283\sqrt{0.01 \times 9.1 \times 10^{-12}}} = 527.8 \text{ kHz}$$

Then the frequency of oscillations for the oscillator is 527.8 kHz.

13.5

THE RC OSCILLATOR

So far, only *LC* tuned circuits that cause phase shift of 180° due to inductive or capacitive coupling in addition to a 180° phase shift produced by the transistor or op-amp, have been discussed. Such *LC* oscillators are employed to generate high-frequency oscillations but they cannot be employed for generation of low frequency oscillations as they become too bulky and expensive. *RC* oscillators are commonly used for generating audio-frequencies as they provide good frequency stability and waveform. When an *RC* network is connected in class-A configuration, a single stage amplifier will produce 180° of phase shift between its output and input signals. If an oscillator has to oscillate a sufficient positive feedback of the correct phase must be provided with the amplifier being used as an inverting stage to achieve this. In an *RC* oscillator, the input is shifted 180° through the amplifier stage and 180° again through a second inverting stage giving 360° ($180^\circ + 180^\circ$) of phase shift which is the same as 0° thereby providing the required positive feedback. This method of phase shift between the input to an *RC* network and the output from the same network is employed in a resistance-capacitance oscillator or simply an *RC* oscillator.

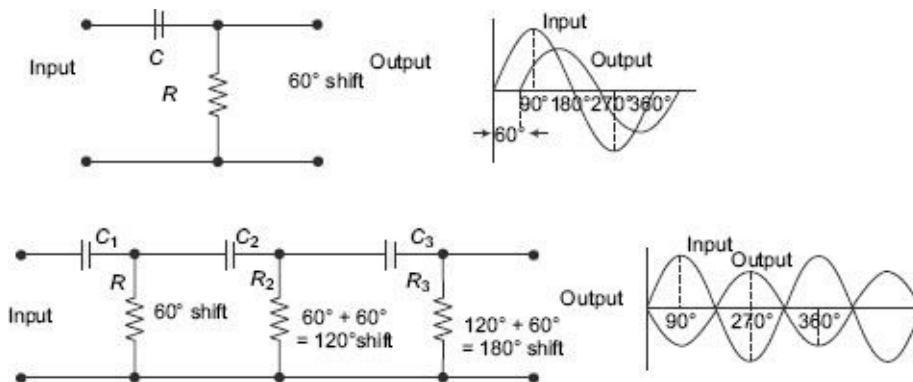

Figure 13.8 *RC* phase-shift network

In [Figure 13.8](#), the circuit on the top shows a single resistor-capacitor network and whose output voltage leads the input voltage by some angle less than 90° . An ideal *RC* circuit would produce a phase shift of exactly 90° , as it is known that the amount of actual phase shift in the circuit depends upon the values of the resistor, capacitor and the chosen frequency of oscillations. The phase angle (Φ) is given as

$$\Phi = \tan^{-1} \left(\frac{R}{X_C} \right)$$

In this simple example above, the values of *R* and *C* have been chosen so that at the required frequency, the output voltage leads the input voltage by an angle of about 60° .

Then by cascading or connecting together three such RC networks in series, it is possible to produce a total phase shift in the circuit of 180° at the chosen frequency and it forms the basis of an RC oscillator circuit. It is known that in an amplifier circuit, either using a BJT or Op-AMP, it will produce a phase-shift of 180° between its input and output. If an RC phase-shift network is connected between this input and output of the amplifier, the total phase shift will become 360° , i.e. the feedback is in-phase.

13.5.1 Basic RC Oscillator Circuit

The RC oscillator as shown in Figure 13.9, which is called a phase-shift oscillator, produces a sine-wave output signal using regenerative feedback from the resistor-capacitor combination.

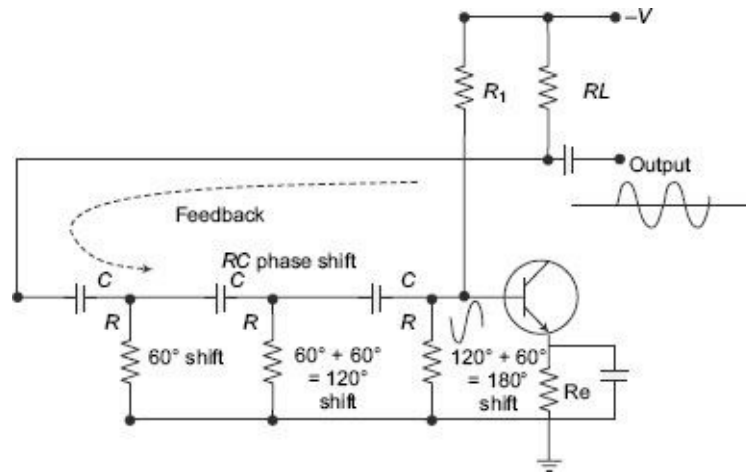

Figure 13.9 Basic RC oscillator circuit

This regenerative feedback from the RC network is possible due to the capability of the capacitor to store an electric charge. The resistor-capacitor feedback network can be connected as shown above to produce a leading phase shift or interchanged to produce a lagging phase and the outcome is still the same as the sine-wave oscillations only occur at the frequency at which the overall phase shift is 360° . By varying one or more of the resistors or capacitors in the phase-shift network, the frequency can be varied and generally this is done using a 3-ganged variable capacitor. If all the resistors R and the capacitors C are equal in value then the frequency of oscillations produced by the oscillator is given

$$f = \frac{1}{2\pi\sqrt{2NRC}}$$

where f is the output frequency in Hz, R is the resistance in ohms, C is the capacitance in farads, N is the number of RC stages and in our example, $N = 3$

13.5.2 The Op-amp RC Oscillator

Operational Amplifier (Op-amp) RC oscillators are more common than their bipolar transistor counterparts. The RC network that produces the phase shift is connected from the op-amps output back to its non-inverting input as shown in Figure 13.10.

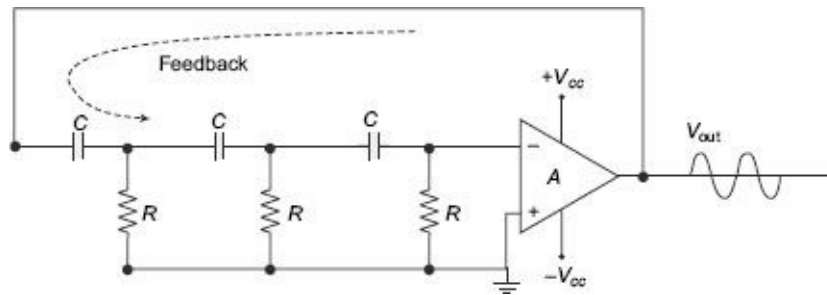

Figure 13.10 Operational-amplifier RC oscillators

The feedback is connected to the non-inverting input and the operational amplifier is connected in its inverting amplifier configuration which produces the required 180° phase shift. The RC network produces the other 180° phase shift at the required frequency. Although it is possible to cascade together two RC stages to provide the required 180° of phase shift, but in that case the stability of the oscillator at low frequencies is poor. One of the most important characteristics of an RC oscillator is its frequency stability. This is the ability of an oscillator to provide a constant frequency output under varying load conditions. So to obtain higher frequency stability, three or even four RC stages together are cascaded. RC oscillators with four stages are widely used because commonly available operational amplifiers come in quad IC packages. So, designing a 4-stage oscillator with 45° of phase shift relative to each other is comparatively easy. RC oscillators are stable and provide a well-shaped sine-wave output with the frequency being proportional to $1/RC$. Using a variable capacitor, a wider frequency range is possible. However, the use of RC oscillators are restricted to low-frequency applications, because of their bandwidth limitations to produce the desired phase shift at high frequencies.

Example 13.3

Determine the frequency of oscillations of a RC oscillator circuit having three-stages each with a resistor and capacitor of equal values. $R = 10\text{ k}\Omega$ and $C = 500\text{ pF}$

Solution Here, $R = 10\text{ k}\Omega$, $C = 500\text{ pF}$, $N = 3$

Therefore, the frequency of oscillation is given as

$$f = \frac{1}{2\pi\sqrt{2NRC}} = \frac{1}{2\pi\sqrt{(2 \times 3) \times 10000 \times 500 \times 10^{-12}}} = 12995\text{ Hz} \approx 13\text{ kHz}$$

13.6

WIEN BRIDGE OSCILLATORS

The Wien bridge oscillator is another type of oscillator which uses a RC network in place of the conventional LC tuned circuit to produce a sinusoidal output waveform. The Wien bridge oscillator is a two-stage RC coupled amplifier circuit that has good stability at its resonant frequency, low distortion and is very easy to tune making it a popular circuit as an audiofrequency oscillator. The phase shift of the output signal is considerably different from the previous RC oscillators.

The Wien bridge oscillator employs a feedback circuit consisting of a series RC circuit connected with a parallel RC of the same component values producing a phase delay-

advance (lag-lead) circuit depending upon the frequency as shown in [Figure 13.11](#).

The above RC network is a typical second-order frequency dependent band-pass filter with high quality factor(Q). It consists of a low-pass filter (series RC network) and another high-pass filter (parallel RC network). At low frequencies, the reactance X_c of the series capacitor is very high so the series capacitor acts like an open circuit and blocks any input signal V_{in} and therefore there is no output signal V_{out} . At high frequencies, the reactance of the parallel capacitor is very low so the parallel capacitor acts like a short circuit on the output, so again there is no output signal. However, between these two extremes, the output voltage reaches a maximum and the frequency at which this happens is called the resonant frequency (f_r) as the circuit's reactance equals its resistance $X_c = R$. At this resonant frequency, the output voltage is one third (1/3) of the input voltage.

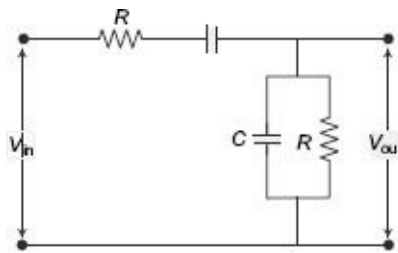

Figure 13.11 RC phase shift network

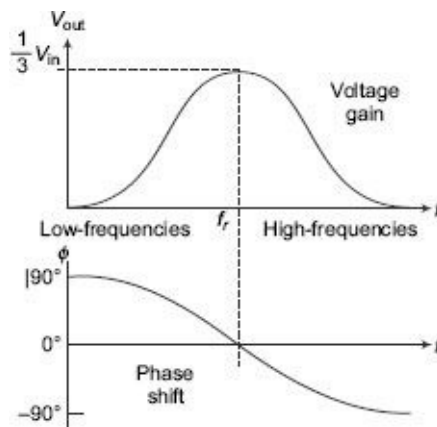

Figure 13.12 Output gain and phase shift

It can be seen as in [Figure 13.12](#) that at very low frequencies, the phase angle between the input and output signals is positive, i.e. leading in nature, while at very high frequencies the phase angle becomes negative, i.e. lagging in nature. In the middle of these two points the circuit is at its resonant frequency (f_r) with the signals being in-phase or 0° . The expression of resonant frequency is as follows:

$$f_r = \frac{1}{2\pi\sqrt{LC}}$$

This frequency-selective RC network forms the basis of the Wien Bridge oscillator circuit. The Wien bridge oscillator circuit is produced by placing this RC network across a non-inverting amplifier. As in [Figure 13.13](#), the output of the operational amplifier is fed back to the inputs in-phase with part of the feedback signal connected to the inverting input terminal via the resistor divider network of R_1 and R_2 , while the other part is fed back to the non-inverting input terminal via the RC network. Then at the selected resonant frequency (f_r), the voltages applied to the inverting and non-inverting inputs will be equal and in-phase. So the positive feedback will cancel the negative feedback signal causing

the circuit to oscillate. Also the voltage gain of the amplifier circuit should be 3 as set by the resistor network, R_1 and R_2 .

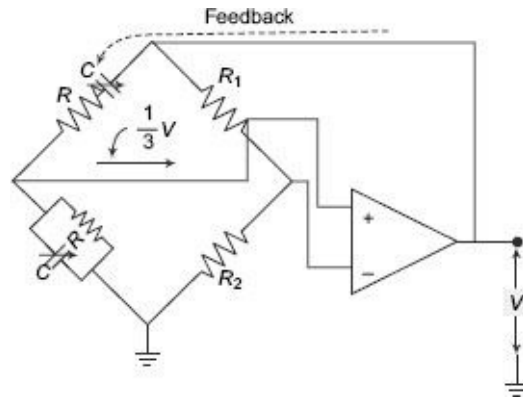

Figure 13.13 Wien bridge oscillator with op-amp

Example 13.4

Determine the maximum and minimum frequency of oscillations of a Wien bridge oscillator circuit having a resistor of $10\text{ k}\Omega$ and a variable capacitor of 1 nF to 1000 nF .

Solution The frequency of oscillations for a Wien bridge oscillator is given as:

$$f_r = \frac{1}{2\pi RC}$$

$$\text{Lowest frequency, } f_{\min} = \frac{1}{2\pi(10\text{ k}\Omega) \times (1000 \times 10^{-9})} = 15.9\text{ Hz}$$

$$\text{Highest frequency, } f_{\max} = \frac{1}{2\pi(10\text{ k}\Omega) \times (1 \times 10^{-9})} = 15915\text{ Hz}$$

13.7

CRYSTAL OSCILLATORS

Frequency stability is the most important feature of an oscillator. Frequency stability is the ability to provide a constant frequency output under varying load conditions. Frequency stability of the output signal can be improved by proper selection of the components used for the resonant feedback circuit including the amplifier but there is a limit to the stability that can be obtained from normal LC and RC tank circuits. Some of the factors that affect the frequency stability of an oscillator include temperature, variations in the load and changes in the power supply. For very high stability, a quartz crystal is generally used as the frequency-determining device to produce a typical type of oscillator circuit known as crystal oscillators.

The crystal oscillators are implemented using the piezo-electric effect. This is actually realised when a voltage source is applied to a small thin piece of crystal quartz. The quartz crystal begins to change shape. This piezo-electric effect is the property of a crystal by which an electrical charge produces a mechanical force by changing the shape of the crystal. In reverse sense, a mechanical force applied to the crystal produces an electrical charge. This piezo-electric effect produces mechanical vibrations or oscillations which are used to replace the LC tank circuit and can be seen in many different types of crystal

substances with the most important of these for electronic circuits being the quartz minerals because of their superior mechanical strength.

The quartz crystal is a very small, thin piece or wafer of cut quartz with the two parallel surfaces metalised to make the electrical connections in a crystal oscillator. The physical size and thickness of a piece of quartz crystal is tightly controlled since it affects the final frequency of oscillations and is called the *characteristic frequency of the crystal*. Once cut and shaped, the crystal cannot be used at any other frequency. The crystal's characteristic or resonant frequency is inversely proportional to its physical thickness between the two metalised surfaces. A mechanically vibrating crystal can be represented by an equivalent electrical circuit consisting of low resistance, large inductance and small capacitance as shown in [Figure 13.14](#).

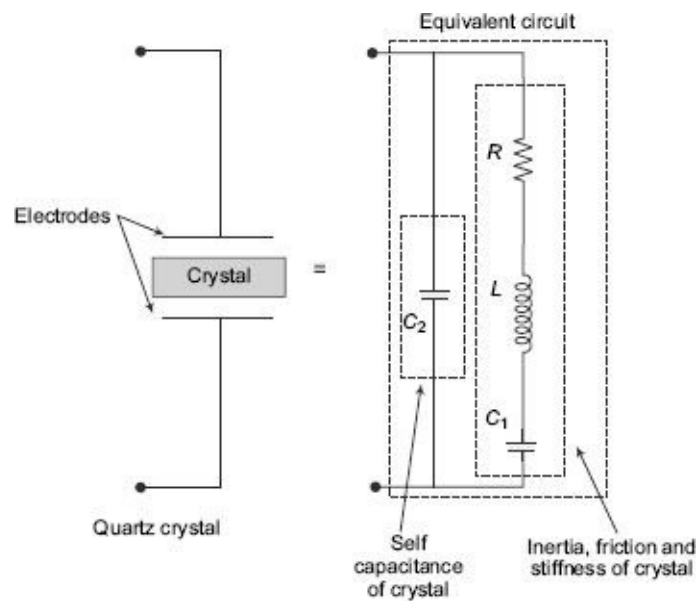

Figure 13.14 Quartz crystal

Like an electrically tuned tank circuit, a quartz crystal has resonant frequency with very high Q factor due to low resistance. The frequencies of quartz crystals range from 4 kHz to 10 MHz. The cut of the crystal also determines how it will vibrate and behave as some crystals will vibrate at more than one frequency. Also, if the crystal is of varying thickness, it has two or more resonant frequencies having both a fundamental frequency and harmonics such as second or third harmonics. However, usually the fundamental frequency is more pronounced than the others and this is the one used. The equivalent circuit above consists of three reactive components and there are two resonant frequencies, the lowest is a series-type frequency and the highest a parallel-type resonant frequency.

In a crystal oscillator circuit, the oscillator will oscillate at the crystal's fundamental series resonant frequency as the crystal always intends to oscillate when a voltage source is applied to it. It is also possible to tune a crystal oscillator to any even harmonic of the fundamental frequencies, (2nd, 4th, 8th, etc.) and these are known generally as harmonic oscillators while overtone oscillators vibrate at odd multiples of the fundamental frequencies, (3rd, 5th, 11th, etc). Crystal oscillators that operate at overtone frequencies do so using their series resonant frequency.

13.7.1 Colpitts Crystal Oscillator

The design of a Colpitts crystal oscillator is very similar to the Colpitts oscillator. The LC tank in the Colpitts oscillator circuit has been replaced by a quartz crystal as shown below in [Figure 13.15](#). The input signal to the base of the transistor is inverted at the transistor's output. The output signal at the collector is then taken through a 180° phase shifting network which contains the crystal operating in a series resonant mode.

The output is fed back to the input which is in phase with the input providing the necessary positive feedback. Resistors R_1 and R_2 bias the transistor in class-A operation and the resistor R_e is taken so that the loop gain is slightly higher than unity. Capacitors C_1 and C_2 are made as large as possible in order to get the frequency of series resonant mode of the crystal.

This frequency does not depend upon the values of these capacitors. The circuit diagram above of the Colpitts crystal oscillator circuit shows that capacitors C_1 and C_2 shunt the output of the transistor which reduces the feedback signal. Therefore, the gain of the transistor limits the maximum values of C_1 and C_2 . Another important point is that the output amplitude should be kept low in order to avoid excessive power dissipation in the crystal, otherwise, the crystal could destroy itself by excessive vibration.

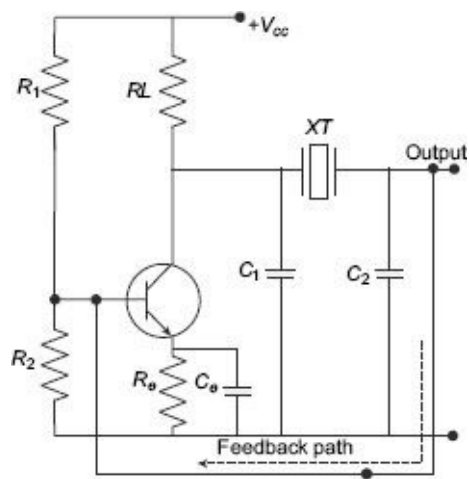

Figure 13.15 Colpitts crystal oscillator

13.8

PIERCE OSCILLATOR

The Pierce oscillator is another common design of a crystal oscillator. It uses the crystal as part of its feedback path instead of the resonant tank circuit. A JFET is used as amplifier as it provides a very high input impedance with the crystal connected between the drain (output) terminal and the gate (input) terminal as shown in [Figure 13.16](#).

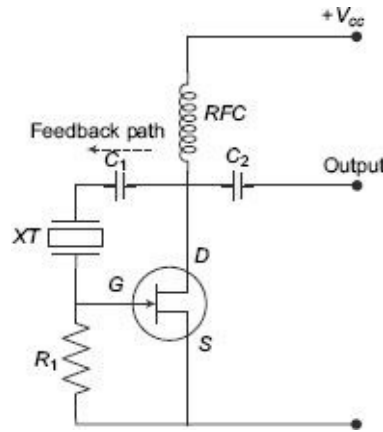

Figure 13.16 *Pierce crystal oscillator*

In the above circuit, the crystal determines the frequency of oscillations and operates on its series resonant frequency giving a low-impedance path between output and input. It gives 180° phase shift at resonance and makes the feedback positive. The maximum voltage range at the drain terminal sets the amplitude of the output sine wave. Resistor R_1 regulates the amount of feedback and crystal drive. The voltage across the Radio Frequency Choke (RFC) reverses during each cycle. The Pierce oscillator can be implemented using the minimum number of components. Because of this, Pierce oscillators are used to design most digital clocks, watches and timers, etc.

13.9

MICROPROCESSOR CLOCKS

The crystal quartz oscillator is the most suitable frequency-determining device in virtually all microprocessors, microcontrollers, PICs and CPUs, used to generate their clock waveforms. Crystal oscillators provide the highest accuracy and frequency stability compared to resistor-capacitor or inductor-capacitor oscillators. The CPU clock dictates how fast the processor can process the data, and a microprocessor having a clock speed of 3 MHz means that it can process data internally 3 million times a second at every clock cycle. Generally, all that is needed to produce a microprocessor clock waveform is a crystal and two ceramic capacitors of values ranging between 15 to 33 pF as shown in [Figure 13.17](#).

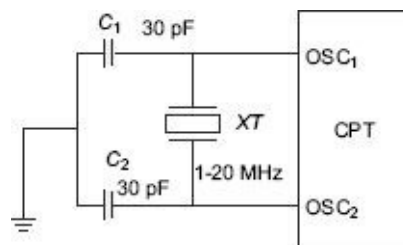

Figure 13.17 *Microprocessor oscillator*

Most microprocessors, microcontrollers and PICs have two oscillator pins labelled OSC_1 and OSC_2 to connect to an external quartz crystal, RC network or even a ceramic resonator. In this application, the crystal oscillator produces a train of continuous square-wave pulses whose frequency is controlled by the crystal which in turn executes the instructions that control the device.

Table 13.1 Oscillators with their operating frequency range

Type of oscillator	Approximate frequency range
Crystal oscillator	Fixed frequency
Wien bridge oscillator	1 Hz to 1 MHz
Phase-shift oscillator	1 Hz to 10 MHz
Hartley oscillator	10 kHz to 100 MHz
Colpitts oscillator	10 kHz to 100 MHz

13.10

SQUARE WAVE AND PULSE GENERATORS

Wave shape, or wave profile, of a single pulse is shown in [Figure 13.18](#). The characteristics of a single pulse are given below.

- The voltage rises very rapidly from zero to its maximum value.
- It stays steady at the maximum value for a time.
- It then falls very rapidly back to zero.
- The duration of a pulse can be anywhere from a very long time (days) to a very short time (picoseconds or less).
- Pulses do not rise and fall instantaneously but take time (which may be very short).
- They are called the rise and fall times.

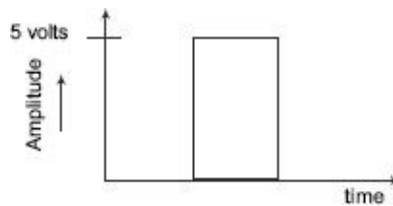

Figure 13.18 Wave shape of a single-pulse

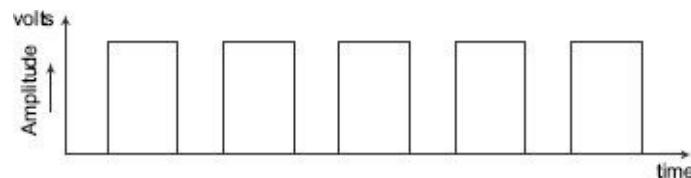

Figure 13.19 Waveform of pulse train

As shown in [Figure 13.19](#), a few characteristics of pulse trains are stated below:

- If pulses occur one after another, they are called a pulse train.
- The duration time of a pulse is called the *mark*.
- The time between pulses is called the *space*.
- The relative times are expressed as the *mark-to-space ratio*.
- Mark to space ratios may vary.

13.10.1 Typical Square Wave Generator

A continuous signal with regular wave shape is one requirement in a wide range of applications. One of the most important of these is a square-wave generator.

The circuit in [Figure 13.20](#) uses an op-amp as comparator with both positive and

negative feedback to control its output voltage. Because the negative feedback path uses a capacitor while the positive feedback path does not, there is a time delay before the comparator is triggered to change state. As a result, the circuit oscillates, or keeps changing state back and forth at a predictable rate.

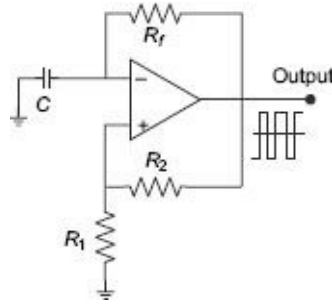

Figure 13.20 Square wave generator circuit using op-amp

Since no force or excitation is given to limit the output voltage, it will switch from one extreme to the other. If it is assumed that output voltage starts at -12 volts then the voltage at the positive or non-inverting input terminal will be set by R_2 and R_1 to a fixed voltage equal to $-12 R_1/(R_1 + R_2)$ volts. Now, it becomes the reference voltage for the comparator, and the output will remain unchanged until the negative or inverting input terminal becomes more negative than this value. But the inverting terminal is connected to a capacitor (C) which is gradually charging in a negative direction through the resistor R_f . Since C is charging towards -12 volts, but the reference voltage at the non-inverting input is necessarily smaller than the -12 volt limit, eventually the capacitor will charge to a voltage that exceeds the reference voltage. When that happens, the circuit will immediately change state. The output will become $+12$ volts and the reference voltage will abruptly become positive rather than negative. Now the capacitor will charge towards $+12$ volts, and the other half of the cycle will take place. The output frequency is given by the approximate equation:

$$f_{\text{out}} = \frac{1}{2R_f C \ln\left(\frac{2R_1}{R_2} + 1\right)}$$

In the practical field, the circuit-component values are chosen such that R_1 is approximately $R_f/3$, and R_2 is in the range of 2 to 10 times R_1 .

13.10.2 OP-AMP Astable Multivibrator and Monostable Multivibrator Circuits

Relaxation oscillators are normally non-sinusoidal waveform generators. The relaxation oscillator using an op-amp shown in [Figure 13.21](#) is a square-wave generator. Square waves are relatively easy to generate.

The frequency of oscillation of a circuit is dependent on the charging and discharging of a capacitor C through the feedback resistor R_f . The main component of the oscillator is an inverting op-amp working as comparator. A comparator circuit has positive feedback which increases the gain of the amplifier. A comparator circuit having positive feedback offers two advantages.

First, the high gain causes the op-amp's output to switch very quickly from one state to another and vice versa. Second, the use of positive feedback gives the hysteresis loop in the circuit operation.

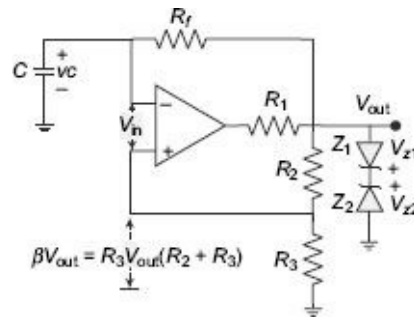

Figure 13.21 Op-amp square-wave generator

As shown in [Figure 13.21](#), in the op-amp square-wave generator, the output voltage V_{out} is connected to ground through two Zener diodes Z_1 and Z_2 , connected back-to-back and is limited to either V_{Z2} or V_{Z1} . A fraction of the output is fed back to the non-inverting (+) input terminal. A combination of R_f and C act as a low-pass RC circuit which is used to integrate the output voltage V_{out} . The capacitor voltage V_c is applied to the inverting input terminal instead of external signal.

At that point of time, the differential input voltage is given as $V_{in} = V_c - \beta V_{out}$.

When V_{in} is +ve $V_{out} = -V_{z1}$

and when V_{in} is -ve, $V_{out} = +V_{z2}$.

Consider an instant when $V_{in} < 0$. At this instant, $V_{out} = +V_{z2}$, and the voltage at the non-inverting (+) input terminal is βV_{z2} , the capacitor C charges exponentially towards V_{z2} , with a time constant $R_f C$. The output voltage remains constant at V_{z2} until v_c equal βV_{z2} . When it happens, comparator output reverses to $-V_{z1}$. Now v_c changes exponentially towards $-V_{z1}$ with the same time constant and again the output makes a transition from $-V_{z1}$ to $+V_{z2}$ when V_c equals $-\beta V_{z1}$

Let $V_{z1} = V_{z2}$

The time period, T of the output square wave is determined using the charging and discharging phenomena of the capacitor C . The voltage across the capacitor V_c when it is charging from $-B V_z$ to $+V_z$ is given by

$$V_c = [1 - (1 + \beta)]e^{-T/2\tau}$$

where $\tau = R_f C$

The waveforms of the capacitor voltage v_c and output voltage V_{out} (or v_z) are shown in [Figure 13.22](#).

When $t = t/2$,

$$V_c = +\beta V_z \text{ or } +\beta V_{out}$$

Therefore, $\beta V_z = V_z [1 - (1 + \beta)e^{-T/2\tau}]$

or $e^{-T/2\tau} = (1 - \beta)/(1 + \beta)$

or $T = 2\tau \log_e [(1 - \beta)/(1 + \beta)] = 2R_{fc} \log_e [1 + (2R_3/R_2)]$

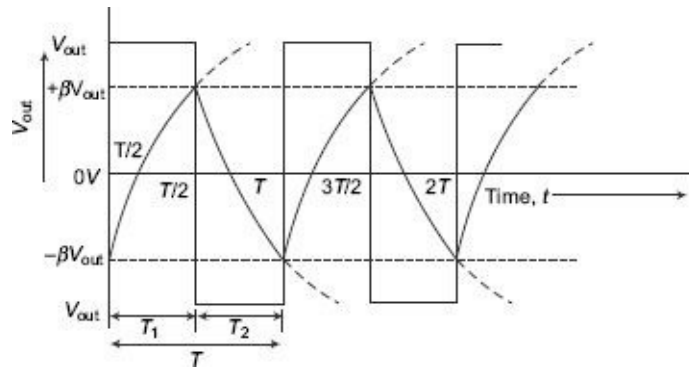

Figure 13.22 Output and capacitor voltage waveforms

Here, the frequency ($f = 1/T$), of the square wave is independent of the output voltage V_{out} . This circuit is also known as free-running or astable multivibrator. This circuit has two quasi-stable states as shown in [Figure 13.22](#). The output remains in one state for the time T_1 and then a rapid transition to the second state and remains in that state for time T_2 . The cycle repeats itself after time $T = (T_1 + T_2)$, where, T is the time period of the square-wave. The op-amp square-wave generator offers good performance in the frequency range of about 10 Hz – 10 kHz. But, at higher frequencies, the slew rate of the op-amp limits the slope of the output square wave. The matching of two Zener diodes Z_1 and Z_2 decides symmetry of the output waveform. The unsymmetrical square wave (T_1 not equal to T_2) can be obtained by choosing different charging time constants for charging the capacitor C to $+V_{out}$ and $-V_{out}$

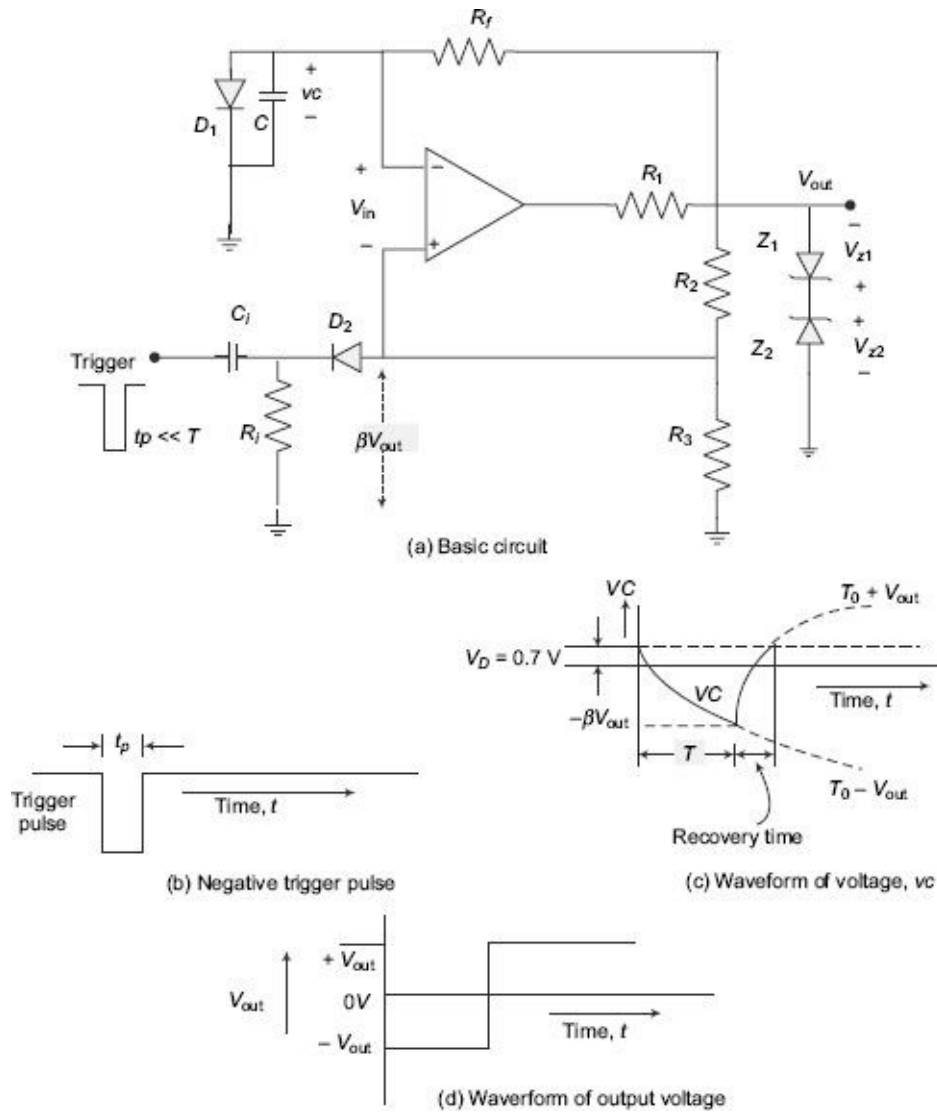

Figure 13.23 Pulse generator/monostable circuit and waveforms

A pulse generator circuit, as shown in [Figure 13.23](#), is a monostable multivibrator. A Monostable Multi Vibrator (MMV) has one stable state and one quasi-stable state. An external triggering pulse pushes the circuit to operate in the quasi-stable state from the stable state. The circuit comes back to its stable state after a time period T . As a result, a single output pulse is generated in response to an input pulse and is referred to as a *one-shot* or *mono shot*. The monostable multivibrator circuit shown in [Figure 13.23](#) is obtained by modifying the previous circuit by connecting a diode D_1 across the capacitor C so as to clamp v_c at v_d during positive excursion.

At steady state, the circuit will remain in its stable state and the output will be $V_{OUT} = +V_{OUT}$ or $+V_z$. The capacitor C is clamped at the voltage $V_D (= 0.7 \text{ V})$. The voltage V_D must be less than βV_{OUT} for $V_{in} < 0$. The circuit can be switched to the other state by applying a negative pulse with amplitude greater than $\beta V_{OUT} - V_D$ to the non-inverting (+) terminal of the op-amp. If a trigger pulse with amplitude greater than $\beta V_{OUT} - V_D$ is given, V_{in} goes positive causing a transition in the state of the circuit to $-V_{out}$. The capacitor C starts charging exponentially with a time constant of $\tau = R_f C$ towards V_{OUT} and diode D_1 becomes reverse-biased. When the capacitor voltage v_c becomes more negative than $-\beta V_{OUT}$, V_{in} becomes negative and, therefore, the output swings back to $+V_{OUT}$ which is

the steady-state output. The capacitor now charges towards $+V_{OUT}$ till v_c attains V_D and capacitor C becomes clamped at V_D . The trigger pulse, capacitor voltage waveform and output voltage waveform are shown in Figure 13. 23(b), 23(c) and 23(d) respectively.

The trigger pulse width T must be much smaller than the duration of the output pulse generated, i.e. $T_p = T$ and for reliable, operation the circuit should not be triggered again before T .

During the quasi-stable state, the exponential profile of the capacitor voltage is expressed as,

$$v_c = -V_{OUT} + (V_{OUT} + V_D)e^{-t/\tau}$$

$$\text{At, } t = T, \quad v_c = -\beta V_{OUT}$$

$$\text{So } -\beta V_{OUT} = -V_{OUT} + (V_{OUT} + v_D) e^{-T/\tau}$$

$$\text{or, } \quad T = R_f C \log_e (1 + V_D/V_{out}) / 1 - \beta$$

Normally, $V_D \ll V_{OUT}$ and taking $R_2 = R_3$

$$\text{The factor, } \beta = R_3/(R_2 + R_3) = 1/2$$

$$\text{So, } \quad T = R_f C \log_e 2 = 0.693 R_f C$$

13.11

TRIANGULAR WAVE GENERATOR

Simply integrating the generated square wave can produce a triangular wave. With the basic squarewave-generator circuit, if a gradually charging capacitor is used to set the timing or frequency of the circuit then the desired triangular signal may be obtained. Since the capacitor is charging through a resistor, the charging profile necessarily follows a logarithmic curve, rather than a linear ramp.

As shown in Figure 13.24, in the right part of the circuit, a separate integrator is used to generate a ramp voltage from the generated square wave. As a result, both waveforms from a single circuit can be obtained. Note that the integrator inverts as well as integrating, so it will produce a negative-going ramp for a positive input voltage, and vice versa.

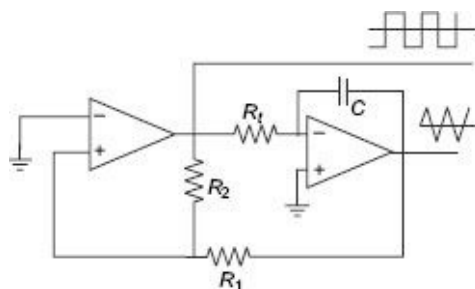

Figure 13.24 Triangular wave generator

Since an op-amp is in use in the integrator, to get the triangle wave, a logarithmic response is not obtained anywhere in the circuit. As a result, the equation for the operating frequency is

$$f_{\text{out}} = \frac{1}{4R_1C} \left(\frac{R_2}{R_1} \right)$$

The square-wave amplitude is still the limit of voltage transition, which are assuming here to be ± 12 volts. The triangle wave's amplitude is set by the ratio of R_1/R_2 .

The circuit shown in [Figure 13.25](#) is an example of a relaxation oscillator designed with two op-amps. The integrator output waveform will be triangular if the input to it is a square wave. So, a triangular-wave generator can be formed by simply cascading an integrator and a square-wave generator, as illustrated in [Figure 13.13.25\(a\)](#). To implement the circuit, a dual op-amp, two capacitors, and at least five resistors are required. The rectangular-wave output swings between $+V_{\text{sat}}$ and $-V_{\text{sat}}$ with a time period determined. The frequency of triangular-waveform and the square waveform are same.

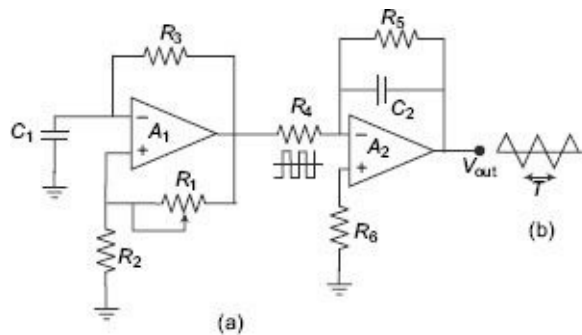

Figure 13.25 Basic circuit of triangular-wave generator

The input to the integrator A_2 is a square wave and its output is a triangular waveform, the output of the integrator will be a triangular wave only when $R_4 C_2 > T/2$; where T is the time period of the square wave. As a general rule, $R_4 C_2$ should be equal to T . To obtain a stable triangular wave, it may also be necessary to shunt the capacitor C_2 with resistance $R_5 = 10 R_4$ and connect an offset volt compensating network at the non-inverting (+) input terminal of the op-amp A_2 . As usual, the frequency of the triangular-wave generator is limited by the op-amp slew rate. It is better to use a high slew rate op-amp (like LM 301), to generate triangular waveforms of relatively higher frequency.

With fewer components, another triangular-waveform generator can be formed and the circuit of that is shown in [Figure 13.26\(a\)](#). The arrangement consists of a Schmitt trigger in non-inverting configuration followed by an integrator. The rectangular wave output of the Schmitt trigger drives an integrator. The integrator generates a triangular wave, which is fed back and used to drive the Schmitt trigger. Thus, the first part of the circuit drives the second part of the circuit, and the second drives the first. But the question arises on how the circuit gets started at the outset. This part is explained as follows.

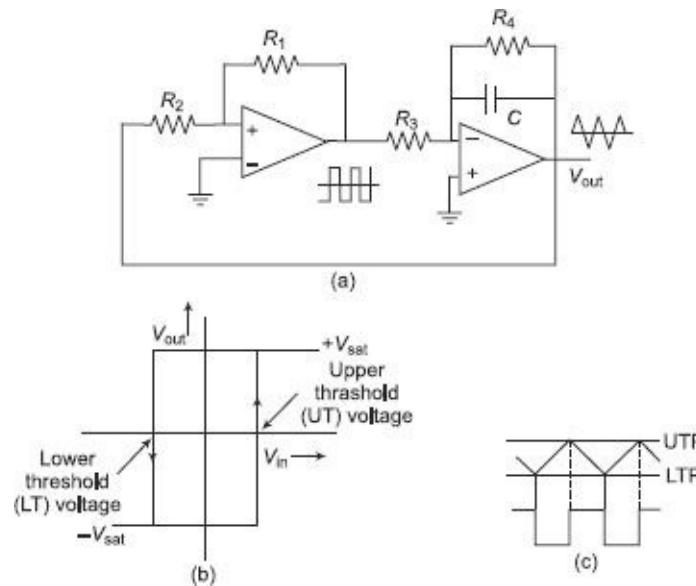

Figure 13.26 (a) Feedback circuit with Schmitt trigger and integrator producing triangular output waveform (b) Transfer characteristic of Schmitt trigger (c) Output waveforms

The fact is that the moment the Schmitt trigger is connected to power supplies, the output of the Schmitt trigger must be either at low state or at high state. If the Schmitt trigger output is low then the output of the integrator will be a rising ramp and for Schmitt trigger of high output, the integrator will produce a falling ramp. In any case, the triangular waveform will start to generate, and the positive feedback to the Schmitt trigger input keeps it going. The transfer characteristic of the Schmitt trigger is shown in [Figure 13.26\(b\)](#). When the output is low, the input must increase to the upper threshold voltage to switch the output to high. Likewise, when the output is high, the input must fall to the lower threshold voltage to switch the output to low. The triangular wave produced by the integrator is capable of driving the Schmitt trigger. When the output of the Schmitt trigger is low, the integrator develops a rising ramp which increases till it reaches the upper threshold voltage, as illustrated in [Figure 13.26\(c\)](#). At this point, the output of the Schmitt trigger switches to the high state and forces the triangular wave to reverse in direction. The negative or falling ramp produced by the integrator now falls till it reaches the upper threshold voltage, where another Schmitt output change occurs.

13.12

SINE WAVE GENERATOR

The demand of sine waves in many electronic applications is very high. The circuit, shown in [Figure 13.27](#) is the scheme to implement a mathematical relationship between the sine and cosine trigonometric functions. By integrating a sine wave, an inverted cosine wave is obtained. A cosine waveform is actually the same waveform as the sine wave but shifted 90° in phase. If that cosine wave is integrated and another 90° phase shift is achieved, it produces a negative sine wave. Of course, each op-amp integrator introduces an inversion as well, so the output of the first integrator is actually a non-inverted cosine wave. This is reversed again by the second integrator, so its output is still a negative sine wave. By inverting the negative sine wave, the original sine wave can be restored.

In this circuit, R_1 is adjusted to ensure that oscillations start and to help set the output

amplitude. The Zener diodes serve to limit the output signal amplitude by limiting the gain of the cosine amplifier beyond the desired level. This prevents the circuit from amplifying the signal beyond its ± 12 volt limits.

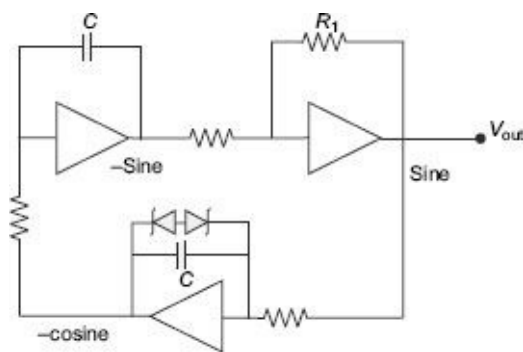

Figure 13.27 A sine-wave generator circuit

The clipping effect caused by the Zener diodes does introduce some distortion, but with a reasonable setting of R_1 this effect is very slight, and the distortion it causes will be significantly reduced by the second integrator.

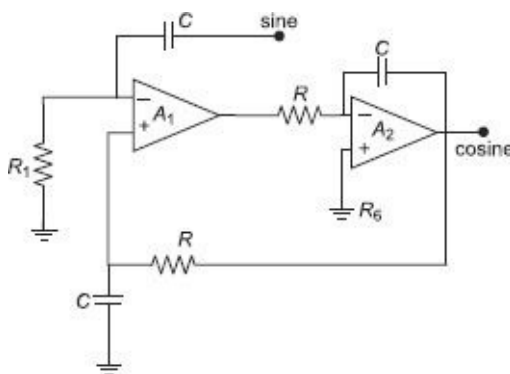

Figure 13.28 A sine-wave oscillator

A classic oscillator circuit is shown in [Figure 13.28](#). In this circuit, the op-amp offsets must be precisely balanced; otherwise, they will accumulate on the two integrators and gradually damp out the oscillations. This circuit can be implemented nicely using a dual op amp such as the 1458. All three capacitors are the same, and R_t is taken very slightly less than R to ensure that the oscillations start the moment power is applied. Here, the frequency of oscillations is $f = 1/2\pi RC$. The frequency response of the op amps in use determines the maximum frequency of oscillations. In the circuit, the loop gain will decrease as frequency increases, and oscillations cannot be sustained if the loop gain is less than 1. The loop gain of this circuit must be greater than 1 to ensure oscillations. This circuit will also tend to clip the output waveforms. However, the same double-Zener clipping scheme in the circuit can be applied to the cosine integrator, to limit the signal amplitude and prevent either op amp from getting saturated.

As both sine and cosine waves are available, this circuit is also known as a *quadrature oscillator*.

A function generator is a signal source that has the capability of producing different types of waveforms as its output signal. The most common output waveforms are sine waves, triangular waves square waves and sawtooth waves. The frequencies of such waveforms may be adjusted from a fraction of a hertz to several hundred kilohertz.

Actually, the function generators are very versatile instruments as they are capable of producing a wide variety of waveforms and frequencies. In fact, each of the waveforms they generate are particularly suitable for a different group of applications. The uses of sinusoidal outputs and square-wave outputs have already been described in the earlier Sections. The triangular-wave and sawtooth wave outputs of function generators are commonly used for those applications which need a signal that increases (or reduces) at a specific linear rate. They are also used in driving sweep oscillators in oscilloscopes and the X-axis of X-Y recorders.

Many function generators are also capable of generating two different waveforms simultaneously (from different output terminals, of course). This can be a useful feature when two generated signals are required for a particular application. For instance, by providing a square wave for linearity measurements in an audio-system, a simultaneous sawtooth output may be used to drive the horizontal deflection amplifier of an oscilloscope, providing a visual display of the measurement result. For another example, a triangular wave and a sine wave of equal frequencies can be produced simultaneously. If the zero crossings of both the waves are made to occur at the same time, a linearly varying waveform is available which can be started at the point of zero phase of a sine wave.

Another important feature of some function generators is their capability of phase locking to an external signal source. One function generator may be used to phase lock a second function generator, and the two output signals can be displaced in phase by an adjustable amount. In addition, one function generator may be phase locked to a harmonic of the sine wave of another function generator. By adjustment of the phase and the amplitude of the harmonics, almost any waveform may be produced by the summation of the fundamental frequency generated by one function generator and the harmonics generated by the other function generator. The function generator can also be phase locked to an accurate frequency standard, and all its output waveforms will have the same frequency, stability and accuracy as the standard.

The block diagram of a function generator is given in [Figure 13.29](#). In this instrument, the frequency is controlled by varying the magnitude of current that drives the integrator. This instrument provides different types of waveforms (such as sinusoidal, triangular and square waves) as its output signal with a frequency range of 0.01 Hz to 100 kHz.

The frequency-controlled voltage regulates two current supply sources. The current supply source 1 supplies constant current to the integrator whose output voltage rises linearly with time. An increase or decrease in the current increases or reduces the slope of the output voltage and thus, controls the frequency.

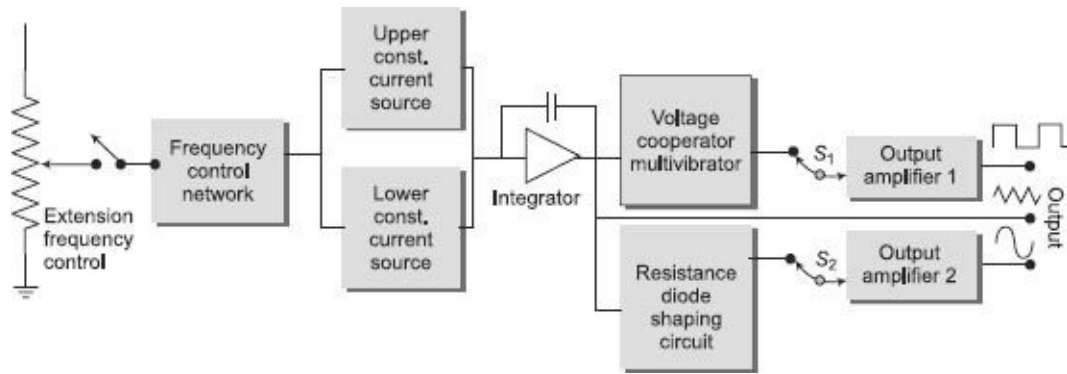

Figure 13.29 *Function generator block diagram*

The voltage comparator multivibrator changes state at a predetermined maximum level, of the integrator output voltage. This change cuts off the current supply from the supply source 1 and switches to the supply source 2. The current supply source 2 supplies a reverse current to the integrator so that its output drops linearly with time. When the output attains a predetermined level, the voltage comparator again changes state and switches on to the current supply source. The output of the integrator is a triangular wave whose frequency depends on the current supplied by the constant-current supply sources. The comparator output provides a square wave of the same frequency as the output. The resistance diode network changes the slope of the triangular wave as its amplitude changes and produces a sinusoidal wave with less than 1% distortion.

Voltage-controlled Oscillator

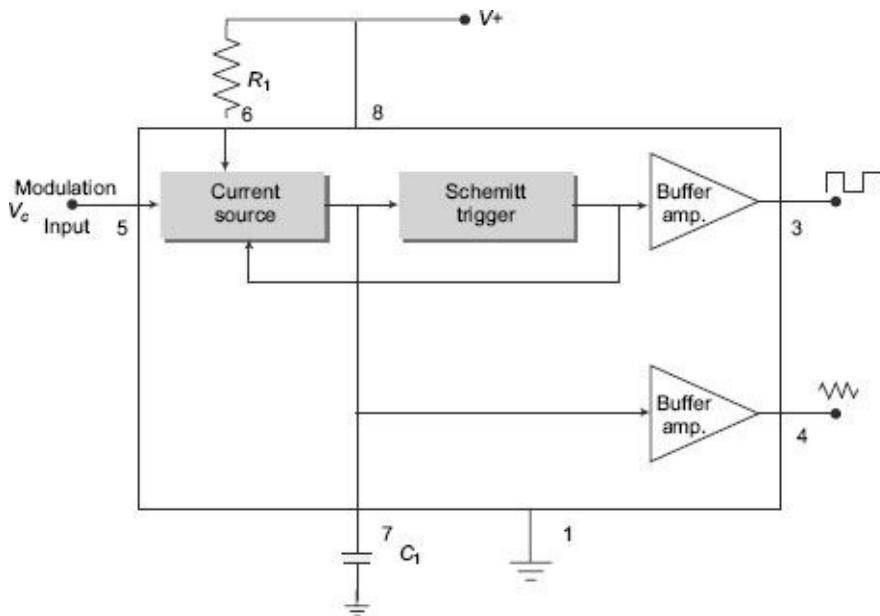

Figure 13.30 *block diagram of voltage-controlled oscillator*

In most cases, the frequency of an oscillator is determined by the time constant RC . However, in cases or applications such as FM, tone generators, and Frequency-Shift Keying (FSK), the frequency is to be controlled by means of an input voltage, called the control voltage. This can be achieved in a Voltage-Controlled Oscillator (VCO). A VCO is a circuit that provides an oscillating output signal (typically of square wave or triangular waveform) whose frequency can be adjusted over a range by a dc voltage. An example of a VCO is the 566 IC unit as shown in [Figure 13.30](#) which provides simultaneously the square-wave and triangular-wave outputs as a function of input voltage. The frequency of oscillation is set by an external resistor R_1 and a capacitor C_1 and the voltage V_c applied to

the control terminals. Figure 13.20 shows that the 566 IC unit contains current sources to charge and discharge an external capacitor C_v at a rate set by an external resistor R_1 and the modulating dc input voltage. A Schmitt trigger circuit is employed to switch the current sources between charging and discharging the capacitor, and the triangular voltage produced across the capacitor and square wave from the Schmitt trigger are provided as outputs through buffer amplifiers. Both the output waveforms are buffered so that the output impedance of each is 50Ω . The typical magnitude of the triangular wave and the square wave are $2.4 V_{\text{peak.to-peak}}$ and $5.4 V_{\text{peak.to-peak}}$.

The frequency of the output waveforms is approximated by

$$f_{\text{out}} = 2(V^+ - V_c)/R_1 C_1 V^+$$

13.14

RF SIGNAL GENERATOR

An RF oscillator is employed for generating a carrier waveform whose frequency can be adjusted typically from about 100 kHz to 30 MHz. Carrier wave frequency can be varied and indicated with the help of a range selector switch and a vernier dial setting. Range is selected by employing frequency dividers. Frequency stability of the oscillator is kept very high at all frequency ranges.

- The following measures are taken in order to achieve stable frequency output.
- Frequency of output voltage changes with the change in supply voltage so regulated power supply is used.
- Buffer amplifiers are used to isolate the oscillator circuit from output circuit so that any change in the circuit connected to the output does not affect the frequency and amplitude of the oscillator output.
- Temperature also causes change in oscillator frequency, so temperature-compensating devices are used.
- Q-factor of the LC circuit should be very high, say above 20,000. This can be achieved by employing quartz crystal oscillator in place of the LC oscillator.
- An audio-frequency modulating signal is generated in another very stable oscillator, called the *modulation oscillator*. Provision is made in the modulation oscillator for changing the frequency and the amplitude of the signal being generated.

In this oscillator, provision is also made to get various types of waveforms such as the square, triangular waves or pulses. The radio-frequency and the modulation-frequency signals are fed to a wide-band amplifier, called the output amplifier. Percentage of modulation can also be adjusted and it is indicated by the meter.

Modulation level can be adjusted up to 95% by a control device. The output of the amplifier is then fed to an attenuator and finally the signal goes to the output of signal generator. The output meter is provided to read the final output signal.

The accuracy to which the frequency of the RF oscillator is known is an important specification of the signal generator performance. Most laboratory-type models are usually calibrated to be within 0.5 – 1.0% of the dial setting. This accuracy is usually sufficient for most measurements. For greater accuracy, if needed, a crystal oscillator, whose frequency is known to be within 0.01% or better, may be used as an internal RF calibration source.

Another key specification of signal generators is their amplitude stability. It is very important that the amplitude of the output signal remains constant as the RF frequency is varied.

13.15

SWEEP FREQUENCY GENERATOR

A sweep frequency generator is a special type of signal generator which generates a sinusoidal output whose frequency is automatically varied or swept between two selected frequencies. One complete cycle of the frequency variation is called a sweep. The rate at which the frequency is varied can be either linear or logarithmic, depending upon the design of a particular instrument. However, the amplitude of the signal output is designed to remain constant over the entire frequency range of the sweep.

Sweep-frequency generators are primarily employed for measurement of responses of amplifiers, filters, and electrical components over various frequency bands. The frequency range of a sweep-frequency generator usually extends over three bands: 0.001 Hz–100 kHz (low frequency to audio), 100 kHz–1,500 MHz (RF range), and 1 – 200 GHz (microwave range). Performance of measurement of bandwidth over a wide frequency range with a manually tuned oscillator is a time-consuming task. With the use of a sweep-frequency generator, a sinusoidal signal that is automatically swept between two chosen frequencies can be applied to the circuit under test and its response against frequency can be displayed on an oscilloscope or X-Y recorder.

Thus, the measurement time and effort is considerably reduced. Sweep generators may also be employed for checking and repairing amplifiers used in TV and radar receivers.

The block diagram of an electronically tuned sweep frequency generator is shown in [Figure 13.31](#)

As shown in [Figure 13.31](#), the main component of a sweep-frequency generator is a master oscillator, usually an RF type, with several operating ranges which are selected by a range switch. The frequency of the output signal of the signal generator may be varied either mechanically or electronically.

In the mechanically varied models, the frequency of the output signal of the master oscillator is varied (tuned) by a motor-driven capacitor.

In the electronically tuned models, the frequency of the master oscillator is kept fixed and a varying frequency signal is produced in another oscillator, called the Voltage Controlled Oscillator (VCO). The VCO contains an element whose capacitance depends upon the voltage applied across it. This element is employed for varying the frequency of

the sinusoidal output of the VCO. The output of the VCO is then combined with the output of the master oscillator in a special electronic device, called the *mixer*. The output of the mixer is sinusoidal, whose frequency depends on the difference of frequencies of the output signals of the master oscillator and VCO. For example, if the master oscillator frequency is fixed at 10.00 MHz and the variable frequency is varied between 10.01 MHz to 35 MHz, the mixer will give sinusoidal output whose frequency is swept from 10 kHz to 25 MHz.

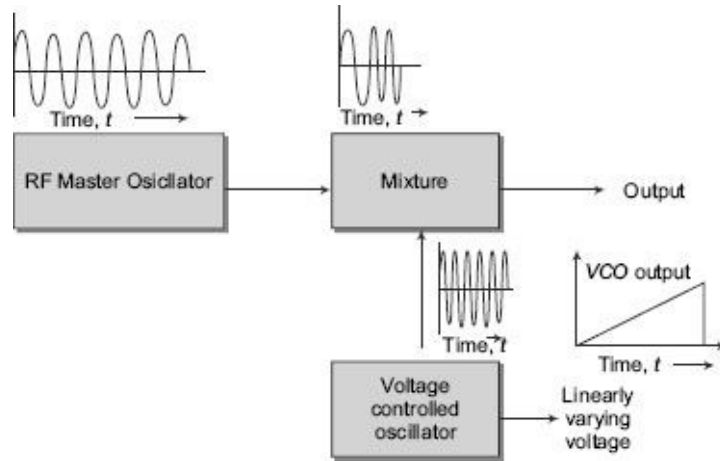

Figure 13.31 Electronically tuned sweep generator

The sweep rates of sweep frequency generators can be adjusted to vary from 100 to 0.01 seconds per sweep. A voltage varying linearly or logarithmically according to sweep rate can be used for driving the X-axis of an oscilloscope or X-Y recorder synchronously. In the electronically tuned sweep generators, the same voltage which drives the VCO serves as this voltage.

The frequency of various points along the frequency-response curve can be interpolated from the values of the end frequencies if it is known how does the frequency vary (i.e. linearly or logarithmically).

A basic system for the sweep generator is shown in [Figure 13.32](#). A low-frequency sawtooth wave is generated from some form of oscillator or waveform generator. The instantaneous voltage of the sawtooth wave controls the frequency of an RF oscillator with its centre frequency set at the centre frequency of the device under test (filter or IF channel etc). Over a single sweep of frequency, RF output voltage from the device, as a function of time, is a plot of the filter response. By rectifying and RF filtering in a simple AM detector, the output is converted to a dc voltage varying as a function of time and this voltage is applied to the vertical input of the CRO. By synchronising the sweep of the CRO with the sawtooth output, the device response is plotted on the CRO screen.

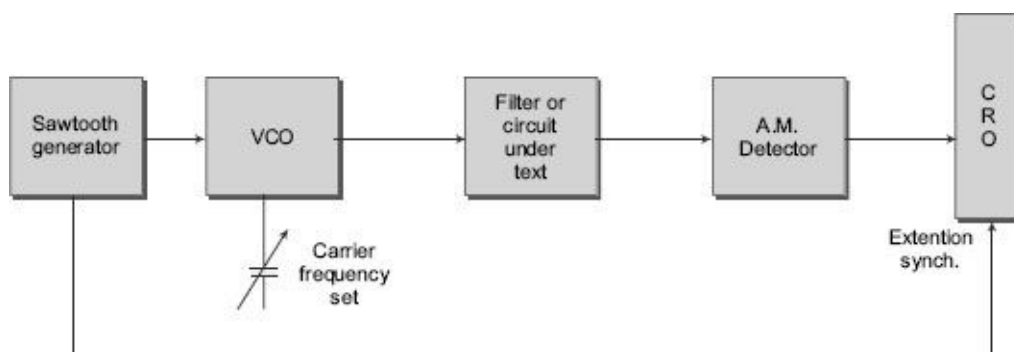

Figure 13.32 Basic sweep-generator arrangement

To achieve this for a range of frequencies, it is easiest to sweep a single frequency (say 1 MHz) and heterodyne this to the test frequency required. The system developed is shown in the block diagram of [Figure 13.32](#). A 1 MHz oscillator is frequency modulated by the output of a sawtooth generator operating at 33 Hz. The modulated output is beat with an external signal generator set to provide the difference frequency centred at the centre frequency of the filter or IF circuit under test. The output of circuit under test is fed to a simple AM detector which provides varying dc output level to feed the CRO vertical input. By synchronising the CRO sweep circuit to the 33 Hz sweep generator, a plot of test circuit response is displayed in terms of amplitude versus frequency.

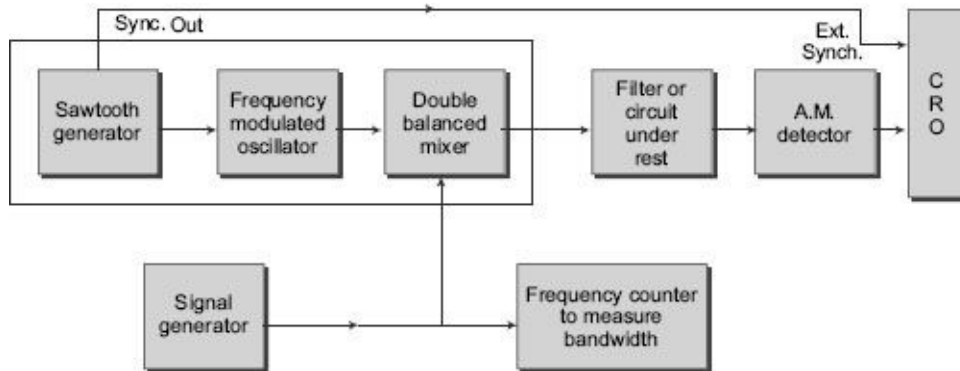

Figure 13.33 The heterodyne sweep generator system—sweep frequency width is independent of output frequency

The Heterodyne Sweep Generator

Circuit detail of the heterodyne sweep generator is shown in [Figure 13.34](#). The operation is described as follows:

The XR205 sawtooth generator N_1 drives a voltage-controlled oscillator N_2 operating at a fixed centre frequency of 1 MHz. This is a very stable IC package type XR2209 which can operate at 1 MHz with its frequency set by external R and C components. Its output at Pin 8 is a triangular waveform and this is shaped to a sine wave by LP filter L_1 , C_{10} , L_2 and C_{11} . The sweep-frequency span is controlled by the amplitude of the sawtooth wave and this is set by the potentiometer R8.

The 1 MHz sweep output is mixed with an external variable signal source (such as a standard signal generator) in a double balanced mixer N_3 . This balances out the two input signals and delivers two frequencies which are the sum and difference of the input signal frequencies. The well-known MC1496 is used for this function and provides a high output level of mixed signals up to around 20 MHz with output falling off as 25 MHz is approached. Its low-frequency performance is limited to around 100 kHz by the primary inductance of coupling transformer T_f , wound on a small ferrite toroidal core. Output level is set by the potentiometer R24 coupled via emitter follower stage V_1 to provide low output impedance. For satisfactory operation, the signal level from the external signal source needs to be around 0.1 to 0.5 VPP.

To set up for a given output frequency, it is only necessary to set the external signal generator to a frequency 1 MHz removed from the required frequency. No tuning is required in the sweep generator itself. Of course, there is always a second image frequency component at the output, but as the filter or IF channel being tested is itself a

selective band-limiting device, the image component is rejected from reaching the detector circuit.

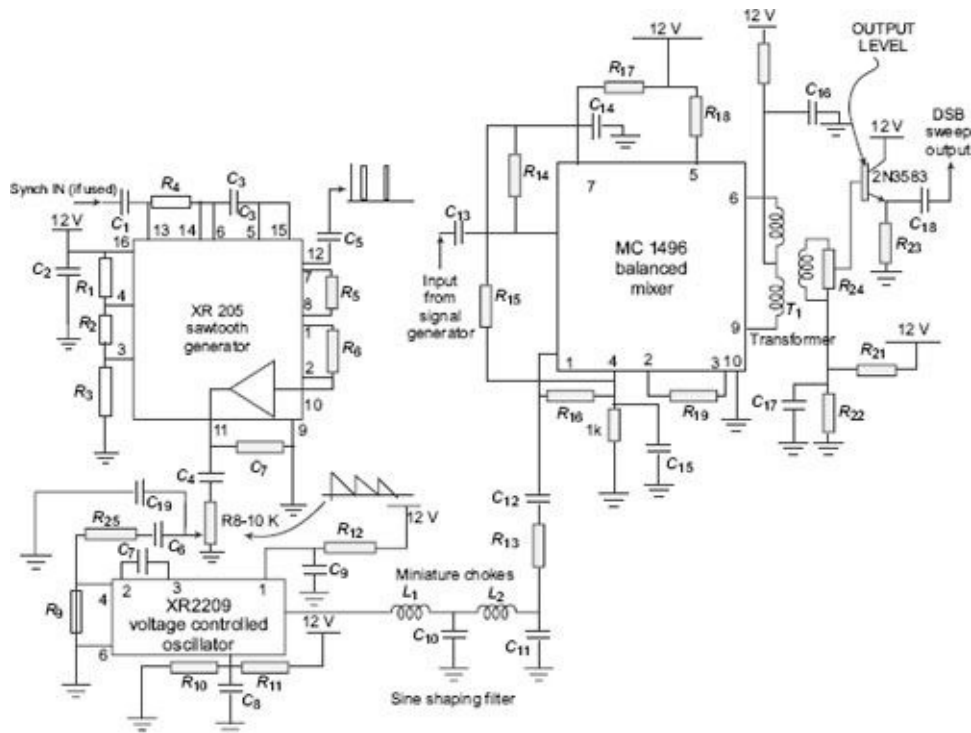

Figure 13.34 Heterodyne sweep generator (100 kHz to 25 MHz) showing sawtooth generator, voltage controlled oscillator and mixer circuits

From an operational point of view, the precise centre frequency of the fixed internal sweep oscillator is not important. However, by setting it right at 1 MHz, the frequency required from the external oscillator becomes obvious without putting pencil to paper or referring to the calculator. The precise frequency of the oscillator can be set to 1 MHz by trimming the value of C7. The XR2209 is a very stable oscillator provided its supply voltage is held constant. Hence, the 12 V supply to the sweep generator must be regulated.

The MC1496 (N_3) used was the TO5 package and the pin numbers shown are for that package. The pin numbers for the DIL package would be different. Packages N_1 and N_2 are both DIL types.

13.16 WAVE ANALYSER

It is well known that any periodic waveform can be represented as a sum of a dc component and a series of sinusoidal harmonics. Analysis of a waveform consists of determination of the values of amplitudes, frequency and sometimes phase angle of the harmonic components. Graphical and mathematical methods may be used for the purpose but methods are quite laborious. The analysis of a complex waveform can be done by electrical means using a bandpass filter network to single out the various harmonic components. Networks of these types pass a narrow band of frequency and provide a high degree of assumptions to all other frequencies.

A wave analyser, in fact, is an instrument designed to measure relative amplitude of single frequency components in a complex waveform. Basically, the instrument acts as a

frequency selective voltmeter which is turned to the frequency of one signal while rejecting all other signal components. The desired frequency is selected by a frequency calibrated dial to the point of maximum amplitude. The amplitude is indicated either by a suitable voltmeter or a CRO.

There are two types of wave analyser, depending upon frequency ranges used: (i) frequency selective wave analyser and (ii) heterodyne wave analyser.

13.16.1 Frequency Selective Wave Analyser

This wave analyser is employed in audio-frequency-range (20 Hz to 20 kHz) measurement. It consists of a narrow band pass filter which can be tuned to the frequency of interest. The block diagram of this analyser is shown in [Figure 13.35](#). The waveform to be analysed in terms of its separate frequency components is applied to an input attenuator that is set by the meter range switch on the front panel. A driver amplifier feeds the attenuated waveform to a high-Q active filter. The filter consists of a cascaded arrangement of *RC* resonant sections and filter amplifiers. The passband of the whole filter section is covered in decade steps over the entire audio range by switch capacitors in the *RC* sections. Close-tolerance polystyrene capacitors are generally used for selecting the frequency ranges. Precision potentiometers are used to tune the filter to any desired frequency within the selection passband. The final amplifier stage supplies the selected signal to the meter circuit and to an unturned buffer amplifier. The buffer amplifier can be used to drive a recorder or an electronic counter. The meter is driven by an average type detector and usually has several voltage ranges as well as a decibel scale. The bandwidth is very narrow, typically about 1% of the selected frequency. [Figure 13.36](#) shows a typical attenuation curve of a wave analyser.

13.16.2 Heterodyne Wave Analyser

This wave analyser is used to measure the frequency in megahertz range. The block diagram of this wave analyser is shown in [Figure 13.37](#). The signal as input is fed through an attenuator and amplifier before being mixed with a local oscillator signal. The frequency of this oscillator is adjusted to give a fixed frequency output which is in the pass band of the amplifier. In the next stage, this signal is mixed with a second crystal oscillator, whose frequency is such that the output from the mixer is centred on zero frequency. The subsequent active filter has a controllable bandwidth, and passes the selected component of the frequency to the indicating meter. Good frequency stability in a wave analyser is achieved by using frequency synthesisers, which have high accuracy and resolution, or by automatic frequency control. In an automatic frequency control system, the local oscillator locks to the signal, and so eliminates the drift between them.

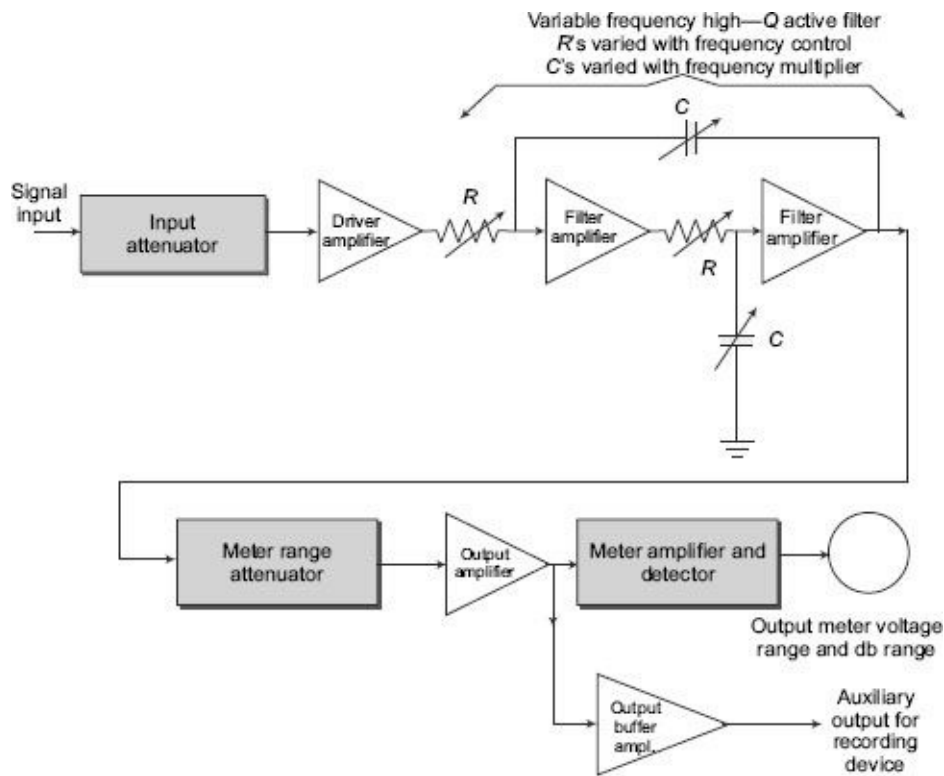

Figure 13.35 Block diagram of a frequency selective wave analyser

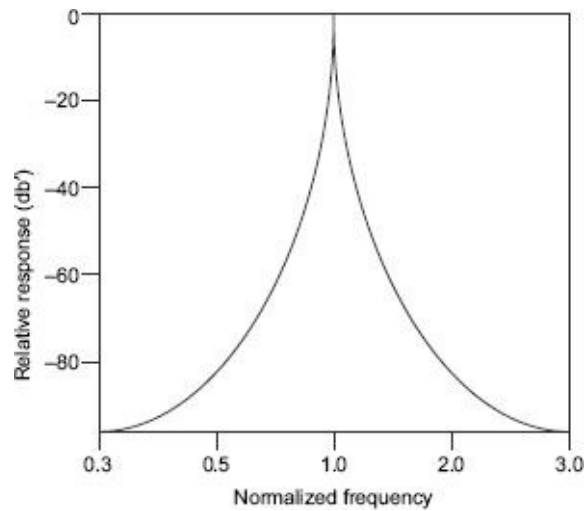

Figure 13.36 Attenuation of a wave analyser

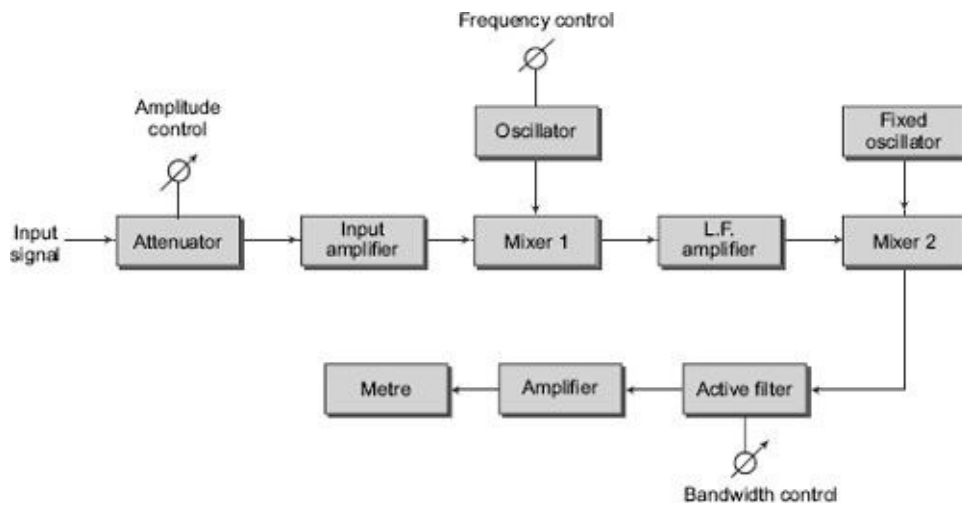

Figure 13.37 Block diagram of a heterodyne wave analyser

13.16.3 Applications of Wave Analysers

Wave analysers have very important applications in the field of i) electrical measurements, ii) sound measurements, and iii) vibration measurements.

Wave analysers are used industrially to detect and reduce the sound and vibration generated by rotating electrical machines and equipment. A good spectrum analysis with a wave analyser shows various discrete frequencies and resonances that can be related to the motion of machines.

13.17

HARMONIC DISTORTION ANALYSERS

Generally, the output waveform of an electronic device, such as an amplifier, should become an exact replica of the input waveform. However, in most of the cases that does not happen due to the introduction of various types of distortions. Distortions may be a result of the inherent non-linear characteristics of components used in the electronic circuit. Non-linear behaviour of circuit elements introduces harmonics in the output waveform and the resultant distortion is often termed Harmonic Distortion (HD).

Types of Distortion

The various types of distortions which occur are explained below.

1. *Frequency Distortion*

This distortion occurs due to the amplification factor of the amplifier is different for different frequencies.

2. *Phase distortion*

This distortion occurs due to the presence of energy-storage elements in the system, which cause the output signal to be displaced in phase with the input signal. If signals of all frequencies are displaced by the same amount, the phase shift distortion would not be observed. However, in actual practice, signals at different frequencies are shifted in phase by different angles and therefore, the phase-shift distortion becomes noticeable.

3. *Amplitude Distortion*

Harmonic distortion occurs due to the fact that the amplifier generates harmonics of the fundamental of the input signal. Harmonics always give rise to amplitude distortion, for example, when an amplifier is overdriven and clips the input signals.

4. *Inter-modulation Distortion*

This type of distortion occurs as a consequence of interaction or heterodyning of two frequencies, giving an output which is the sum or difference of the two original frequencies.

5. *Cross-over Distortion*

This type of distortion occurs in push-pull amplifier due to incorrect bias levels.

6. *Total Harmonic Distortion*

A non-linear system produces harmonics of an input sine wave, the harmonics consists of

a sine wave with frequencies which are multiples of the fundamental of the input signal. The Total Harmonic Distortion (THD) is measured in terms of the harmonic contents of the wave, as given by

$$\text{THD} = \frac{\left[\sum (\text{Harmonics})^2 \right]^{\frac{1}{2}}}{\text{Fundamental}} \times 100\%$$

In a measurement system, noise is read in addition to harmonics, and the total waveform, consisting of harmonics, noise and fundamental, is measured instead of the fundamental alone. Therefore, the measured value of the total harmonic distortion (THD_M) is given by

$$\text{THD}_M = \frac{\left[\sum \{(\text{Harmonics})^2 + (\text{Noise})^2\} \right]^{\frac{1}{2}}}{\left[\sum \{(\text{Fundamental})^2 + (\text{Harmonics})^2 + (\text{Noise})^2\} \right]^{\frac{1}{2}}}$$

Figure 13.38 shows the block diagram of a harmonic distortion analyser which is used to measure THD. The signal source has very low distortion and this can be checked by reading its output distortion by connecting directly into the analyser. The signal from the source is fed into the amplifier under test. This generates harmonics and the original fundamental frequency. The fundamental frequency is removed by a notch filter. In the manual system, as shown in Figure 13.38 (a), the switch *S* is first placed in the position 1 and the total content of fundamental and harmonics (*E_T*) is measured. Then the switch is moved to the position 2 to measure just the harmonics *E_H*. the value of THD is then found using following equation:

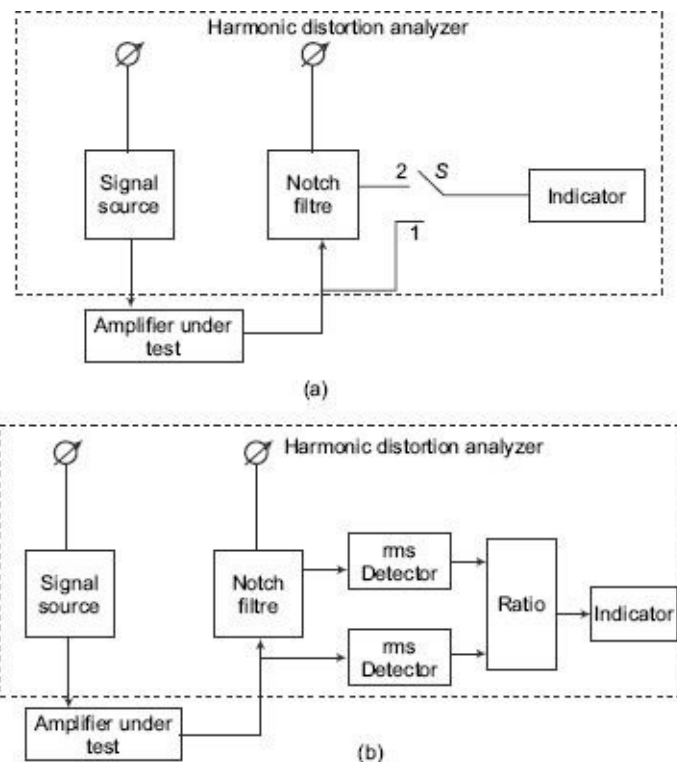

Figure 13.38 Simplified block diagrams of fundamental suppression harmonic distortion analysers: (a) Manual reading (b) Ratio reading

$$\text{THD} = \frac{E_H}{E_T} \times 100\%$$

The meter can be calibrated by putting the switch in the position 1 and adjusting the

reading for full scale deflection. With the switch position 2, the meter reading is now proportional to THD. [Figure 13.28\(b\)](#) shows an alternative arrangement, where the value of E_T and E_H are read simultaneously and their ratio calculated and displayed as THD on the indicator. For good accuracy, the notch filter must have excellent rejection and high pass characteristics. It should attenuate the fundamental by 100 db or more and the harmonics by less than 1 db. The filter also needs to be tuned accurately to the fundamental of the signal source. This is difficult to achieve manually and most distortion analysers do this automatically. A common form of notch filter is a Wien bridge. This balances at one frequency only and at this frequency, the output voltage at the bridge null detector is minimum.

13.18

SPECTRUM ANALYSER

A spectrum analyser is a wide band, very sensitive receiver. It works on the principle of “superheterodyne receiver” to convert higher frequencies (normally ranging up to several 10s of GHz) to measurable quantities. The received frequency spectrum is slowly swept through a range of pre-selected frequencies, converting the selected frequency to a measurable dc level (usually logarithmic scale), and displaying the same on a CRT. The CRT displays received signal strength (y-axis) against frequency (x-axis).

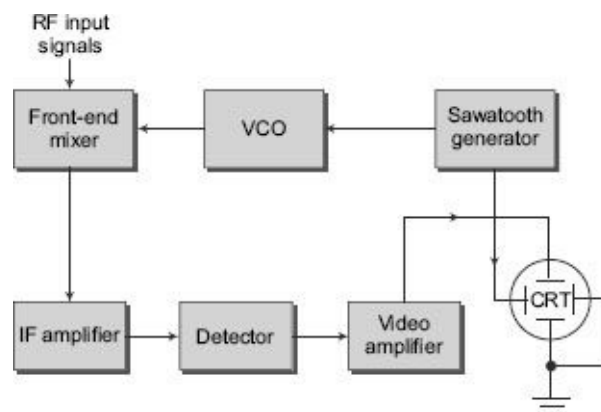

Figure 13.39 Simplified block diagram of a super-heterodyne receiver

As seen from [Figure 13.39](#), it consists of the following parts:

1. Front-end mixer
2. Voltage controlled oscillator
3. Sawtooth generator
4. IF amplifier
5. Detector
6. Video amplifier
7. Cathode Ray Tube (CRT)

The front-end mixer is where the RF input is combined with the local oscillator (VCO) frequency to give IF (Intermediate Frequency) output. The IF frequencies are then fed to an IF amplifier, then to a detector. The output of the detector is fed to the video amplifier. The output from the video amplifier is given to CRT (vertical axis), and the output of the sawtooth generator is given to the horizontal axis of the CRT. Thus, we see the signal

amplitude against the time sweep (which in turn represents the frequency).

Normally, the frequency conversion takes place in multiple stages, and band-pass filters are used to shape the signals. Also, precision amplifiers and detectors are used to amplify and detect the signals.

Obviously, signals that are weaker than the background noise could not be measured by a spectrum analyser. For this reason, the noise floor of a spectrum analyser in combination with RBW is a vital parameter to be considered when choosing a spectrum analyser. The received signal strength is normally measured in decibels (dbm). (Note that 0 dBm corresponds to 1 mWatt of power on a logarithmic scale). The primary reasons for measuring the power (in dBm) rather than voltage in spectrum analysers are the low received signal strength, and the frequency range of measurement. Spectrum analysers are capable of measuring the frequency response of a device at power levels as low as -120 dBm. These power levels are encountered frequently in microwave receivers, and spectrum analysers are capable of measuring the device characteristics at those power levels.

13.18.1 Spectrum Analyser Vs Oscilloscope

1. A spectrum analyser displays received signal strength (y -axis) against frequency (x -axis). An oscilloscope displays received signal strength (y -axis) against time (x -axis).
2. A Spectrum analyser is useful for analysing the amplitude response of a device against frequency. The amplitude is normally measured in dBm in spectrum analysers, whereas the same is measured in volts when using oscilloscopes.
3. Normally, an oscilloscope cannot measure very low voltage levels (say, -100 dBm) and are intended for low-frequency, high-amplitude measurements. A spectrum analyser can easily measure very low amplitudes (as low as -120 dBm), and high frequencies (as high as 150 GHz).
4. The spectrum analyser measurements are in frequency domain, whereas the oscilloscope measurements are in time domain.
5. Also, a spectrum analyser uses complex circuitry compared with an oscilloscope. As a result of this, the cost of a spectrum analyser is usually quite high.

A *signal* is usually defined by a time-varying function carrying some sort of information. Such a function most often represents a time-changing electric or magnetic field, whose propagation can be in free space or in dielectric materials constrained by conductors (waveguides, coaxial cables, etc.). A signal is said to be periodic if it repeats itself exactly after a given time T called the period. The inverse of the period T , measured in seconds, is the frequency f measured in hertz (Hz).

A periodic signal can always be represented in terms of a sum of several (possibly infinite) sinusoidal signals, with suitable amplitude and phase, and having frequencies that are integer multiples of the signal frequency. Assuming an electric signal, the square of the amplitudes of such sinusoidal signals represents the power in each sinusoid, and is said to be the power spectrum of the signal. These concepts can be generalised to an aperiodic signal; in this case, its representation (spectrum) will include a continuous interval of

frequencies, instead of a discrete distribution of integer multiples of the fundamental frequency.

The representation of a signal in terms of its sinusoidal components is called *Fourier analysis*. The (complex) function describing the distribution of amplitudes and phases of the sinusoids composing a signal is called its *Fourier Transform (FT)*. The Fourier analysis can be readily generalised to functions of two or more variables; for instance, the FT of a function of two (spatial) variables is the starting point of many techniques of image processing. A time-dependent electrical signal can be analysed directly as a function of time with an *oscilloscope* which is said to operate in the *time domain*. The time evolution of the signal is then displayed and evaluated on the vertical and horizontal scales of the screen.

The *spectrum analyser* is said to operate in the *frequency domain* because it allows one to measure the harmonic content of an electric signal, that is, the power of each of its spectral components. In this case, the vertical and horizontal scales read powers and frequencies. The two domains are mathematically well defined and, through the FT algorithm, it is not too difficult to switch from one response to the other.

Their graphical, easily perceivable representation is shown in [Figure 13.40](#), where the two responses are shown lying on orthogonal planes. It is trivial to say that the easiest way to make a Fourier analysis of a time-dependent signal is to have it displayed on a spectrum analyser. Many physical processes produce (electric) signals whose nature is not deterministic, but rather stochastic, or random (noise). Such signals can also be analysed in terms of FT, although in a statistical sense only. A time signal is said to be band-limited if its FT is nonzero only in a finite interval of frequencies, say $(F_{\max} - F_{\min}) = B$. Usually, this is the case and an average frequency F_0 can be defined. Although the definition is somewhat arbitrary, a (band-limited) signal is referred to as RF (radio frequency) if F_0 is in the range 100 kHz to 1 GHz and as a microwave signal in the range 1 to 1000 GHz. The distinction is not fundamental theoretically, but it has very strong practical implications in instrumentation and spectral measuring techniques. A band-limited signal can be described further as narrow band, if $B/F_0 \leq 1$, or wide band otherwise.

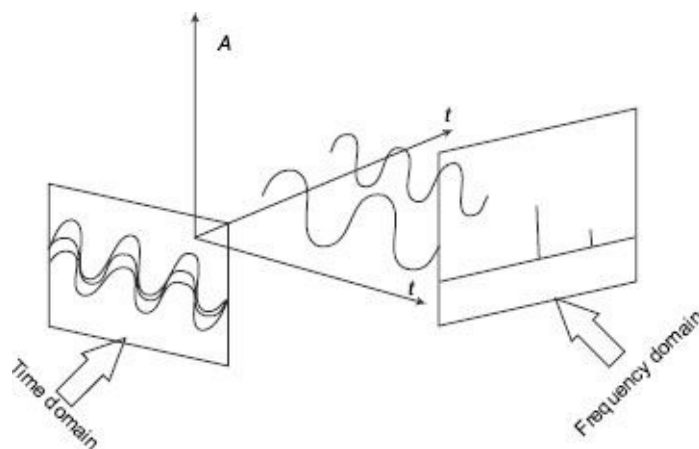

Figure 13.40 How the same signal can be displayed

The first step in performing a spectral analysis of a narrow-band signal is generally the so-called heterodyne down-conversion: it consists in the mixing (beating) of the signal with a pure sinusoidal signal of frequency F_L , called Local Oscillator (*LO*). In principle,

mixing two signals of frequency F_0 and F_L in any nonlinear device will result in a signal output containing the original frequencies as well as the difference ($F_0 - F_L$) and the sum ($F_0 + F_L$) frequencies, and all their harmonic (multiple) frequencies. In the practical case, a purely quadratic mixer is used, with an LO frequency $F_L < F_0$; the output will include the frequencies ($F_0 - FL$), $2FL$, $2F_0$, and ($F_0 + F_L$), and the first term (called the intermediate frequency or IF) will be easily separated from the others, which have a much higher frequency. The bandwidth of the IF signal will be the same as the original bandwidth B ; however, to preserve the original information fully in the IF signal, stringent limits must be imposed on the LO signal, because any deviation from a pure sinusoidal law will show up in the IF signal as added phase and amplitude noise, corrupting the original spectral content. The process of down converting a (band-limited) signal is generally necessary to perform spectral analysis in the very-high-frequency (microwave) region, to convert the signal to a frequency range more easily handled technically. When the heterodyne process is applied to a wideband signal (or whenever $F_L > F_{\min}$), “negative” frequencies will appear in the IF signal. This process is called *double sideband* mixing, because a given IF bandwidth B (i.e., $(FL + B/2)$) will include two separate bands of the original signal, centred at $F_L + IF$ (“upper” sideband) and $F_L - IF$ (“lower” sideband). This form of mixing is obviously undesirable in spectrum analysis, and input filters are generally necessary to split a wide-band signal in several narrow-band signals before down conversion. Alternatively, special mixers can be used that can deliver the upper and lower sidebands to separate IF channels. A band-limited signal in the frequency interval $(F_{\max} - F_{\min}) = B$ is said to be converted to baseband when the LO is placed at $F_L = F_{\min}$, so that the band is converted to the interval $(B - 0)$. No further lowering of frequency is then possible, unless the signal is split into separate frequency bands by means of filters. After down conversion, the techniques employed to perform power-spectrum analysis vary considerably depending on the frequencies involved. At lower frequencies, it is possible to employ analog-to-digital converters (ADC) to get a discrete numerical representation of the analog signal, and the spectral analysis is then performed numerically, either by direct computation of the FT (generally via the fast Fourier transform, FFT, algorithm) or by computation of the signal autocorrelation function, which is directly related to the square modulus of the FT via the Wiener-Khinchin theorem. Considering that the ADC must sample the signal at least at the Nyquist rate (i.e. at twice the highest frequency present) and with adequate digital resolution, this process is feasible and practical only for frequencies (bandwidths) less than a few megahertz. Also, the possibility of a real-time analysis with high spectral resolution may be limited by the availability of very fast digital electronics and special-purpose computers. The digital approach is the only one that can provide extremely high spectral resolution, up to several hundred thousand channels. For high frequencies, several analog techniques are employed.

13.18.2 A Practical Approach to Spectrum Analysis

Spectrum analysis is normally done in order to verify the harmonic content of oscillators, transmitters, frequency multipliers, etc. or the spurious components of amplifiers and mixers. Other specialised applications are possible, such as the monitoring of Radio Frequency Interference (RFI), Electromagnetic Interference (EMI), and Electromagnetic Compatibility (EMC). These applications, as a rule, require an antenna connection and a

low-noise, external amplifier. Which are then the specifications to look for in a good spectrum analyser? We would suggest the following:

1. It should display selectable, very wide bands of the EM radio spectrum with power and frequency readable with good accuracy.
2. Its selectivity should range, in discrete steps, from a few hertz to megahertz so that sidebands of a selected signal can be spotted and shown with the necessary details.
3. It should possess a very wide dynamic range, so that signals differing in amplitude six to eight orders of magnitude can be observed at the same time on the display.
4. Its sensitivity must be compatible with the measurements to be taken. As already mentioned, specialised applications may require external wide-band, low-noise amplifiers and an antenna connection.
5. Stability and reliability are major requests but they are met most of the time.

Occasionally, a battery-operated option for portable field applications may be necessary. A block diagram of a commercial spectrum analyser is shown in [Figure 13.41](#).

Referring to [Figure 13.41](#), we can say that we are confronted with a radio-receiver-like superhet with a wide-band input circuit. The horizontal scale of the instrument is driven by a ramp generator which is also applied to the voltage-controlled LO [2].

A problem arises when dealing with a broadband mixing configuration like the one shown above, namely, avoiding receiving the image band.

The problem is successfully tackled here by upconverting the input band to a high-valued IF. An easily designed input low-pass filter, not shown in the block diagram for simplicity, will now provide the necessary rejection of the unwanted image band.

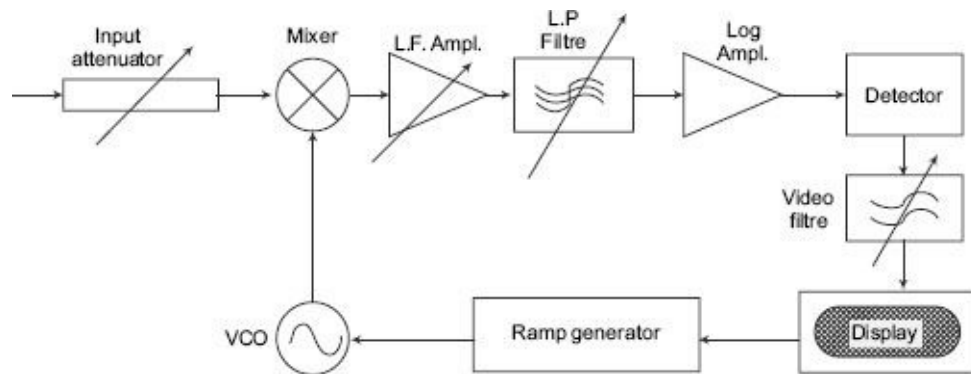

Figure 13.41 Block diagram of a commercial spectrum analyser

Nowadays, with the introduction of YIG bandpass filter preselectors, tunable over very wide input bands, up conversion is not always necessary. Traces of unwanted signals may, however, show up on the display although at very low level (less than -80 dBc) on good analysers.

A block diagram of a commercial spectrum analyser exploiting both the mentioned principles is shown in [Figure 13.41](#). This instrument includes a very important feature which greatly improves its performance: the LO frequency is no longer coming from a free-running source but rather from a synthesised unit referenced to a very stable quartz oscillator. The improved quality of the LO , both in terms of its own noise and frequency

stability, optimises several specifications of the instrument, such as frequency-determining accuracy, finer resolution on display, and reduced noise in general.

Further, a stable *LO* generates stable harmonics which can then be used to widen the input-selected bands up to the millimetre region. As already stated, this option requires external devices, e.g. a mixer. The power reference on the screen is the top horizontal line of the reticle. Due to the very wide dynamic range foreseen, the use of a log scale (e.g., 10 dB/square) seems appropriate. Conventionally, 1 mW is taken as the zero reference level: accordingly, dBm is used throughout. The noise power level present on the display without an input signal connected (noise floor) is due to the input random noise multiplied by the IF amplifier gain. Such a noise is always present and varies with input frequency, IF selectivity, and analyser sensitivity (in terms of noise figure 13.13.). The “on-display dynamic range” of the analyser is the difference between the maximum compression-free level of the input signal and the noise floor. As a guideline, the dynamic range of a good instrument could be of the order of 70 to 90 dB.

An input attenuator, always available on the front panel, allows one to apply more power to the analyser while avoiding saturation and nonlinear readings. The only drawback is the obvious sensitivity loss. One should not expect a spectrum analyser to give absolute power-level readings to be better than a couple of dB.

For the accurate measurement of power levels, the suggestion is to use a power meter. An erratic signal pattern on display and a fancy level indication may be caused by the wrong setting of the “scan time” knob. It must be realised that high-resolution observation of a wide input band requires proper scanning time. An incorrect parameter setting yields wrong readings but usually an optical alarm is automatically switched on to warn the operator.

13.18.3 Spectrum Analyser Applications

1. Device Frequency Response Measurements

You can use spectrum analysers for measuring the amplitude response (typically measured in dbm) against frequency of the device. The device may be anything from a broadband amplifier to a narrowband filter.

2. Microwave Tower Monitoring

You can measure the transmitted power and received power of a microwave tower. Typically, you use a directional coupler to tap the power without interrupting the communications. In this way, you can verify that the frequency and signal strength of your transmitter are according to the specified values.

3. Interference Measurements

Any large RF installations normally require site survey. A spectrum analyser can be used to verify and identify interferences. Any such interfering signals need to be minimised before going ahead with the site work. Interference can be created by a number of different sources, such as telecom microwave towers, TV stations, airport guidance systems, etc.

Other measurements that could be made using a spectrum analyser include the

following:

- Return-loss measurement
- Satellite antenna alignment
- Spurious signals measurement
- Harmonic measurements
- Inter-modulation measurements

Given below are some important features available with few portable spectrum analyser of 9 kHz to 26.5 GHz:

- Colour display
- Continuous 30 Hz to 26.5 GHz sweep
- Fast digital resolution bandwidths of 1, 3, 10, 30 and 100 Hz
- Adjacent channel power, channel power, carrier power, occupied bandwidth percentage and time-gated measurements standard
- Precision timebase and 1 Hz counter resolution
- Measurement personalities for digital radio and phase noise measurements
- Easily transfer screen image or trace data to PC

Note: The above specifications are given as an example only, and may not accurately represent the actual equipment specifications.

EXERCISE

Objective-type Questions

1. Which one of the following oscillators is used for generation of high frequencies?
 - (a) RC phase shift
 - (b) Wien bridge
 - (c) LC oscillator
 - (d) Blocking oscillator
2. A triangular wave can be generated by
 - (a) integrating a square wave
 - (b) differentiating a square wave
 - (c) integrating a sine wave
 - (d) differentiating a sine wave
3. Harmonic distortion is due to
 - (a) change in the behaviour of circuit elements due to change in temperature
 - (b) change in the behaviour of circuit elements due to change in environment
 - (c) linear behaviour of circuit elements
 - (d) nonlinear behaviour of circuit elements
4. A spectrum analyser is a combination of
 - (a) narrow band super-heterodyne receiver and CRO
 - (b) signal generator and CRO
 - (c) oscillator and wave analyser

- (d) VTVM and CRO
5. A spectrum analyser is used across the frequency spectrum of a given signal to study the
- (a) current distribution
 - (b) voltage distribution
 - (c) energy distribution
 - (d) power distribution

Answers

1. (b) 2. (a) 3. (d) 4. (a) 5. (d)

Short-answer Questions

1. What is the initial condition for an oscillator to start?
2. What are the Barkhausen conditions of oscillations?
3. Why are LC resonant circuits impractical at audio frequencies?
4. Why is a crystal oscillator preferred in communication transmitters and receivers?
5. What is a function generator?
6. What is the basic difference between a square-wave generator and pulse generator?
7. What is a Schmitt trigger circuit? Discuss the applications of a Schmitt trigger circuit.
8. What is a VCO? Explain its working principle.

Long-answer Questions

1. Classify oscillators on the basis of design principle. How can an amplifier be converted into an oscillator? What is the role of resonance in an oscillator circuit?
2. What is an oscillator? How does it differ from an amplifier? What are the major parts of an oscillator circuit?
3. Draw the circuit diagram of a Hartley oscillator and explain its operation.
4. Draw the circuit diagram of a Colpitts oscillator and explain its operation.
5. Enumerate the advantages of RC oscillators. Explain the working of an RC phase shift oscillator.
6. Draw and explain the circuit of the Wien bridge oscillator. Derive the expression for frequency of oscillation for such an oscillator. Will oscillations take place if the bridge is balanced?
7. What are the requirements of pulse? Draw a circuit diagram of a generator which produces such pulses.
8. Explain the working of a function generator producing sine, square and triangular waveforms. Draw its block diagram.
9. Draw the circuit diagram of a stable multivibrator. How does it generate square wave?
10. Describe with a block diagram a sweep-frequency generator and its applications.
11. Discuss the working of a wave analyser.
12. With the help of a block diagram, explain the working of a harmonic distortion analyser.
13. What is a wave analyser? Explain the working principle of a heterodyne wave analyser.
14. Distinguish the principles of the working of a spectrum analyser and a wave analyser. Draw the block diagram of a spectrum analyser. Indicate the common applications of a spectrum analyser.

14.1

INTRODUCTION

A data acquisition system is a device or an integrated system used to collect information about the state or condition of various parameters of any process. For example, collecting day-to-day temperature of a particular location can be termed *data acquisition*. Say, a person recording the level of municipal water-storing tank into a piece of paper, is actually performing the task of a data acquisition system. With the advancement of digital electronics, various electronic devices have been developed to perform this kind of recording or logging job.

Now a days, most data acquisition systems are integrated with computer, sensors, signal conditioning devices, etc. and the function of these kind of data acquisition systems varies for simple recording of process parameter to control of industrial system. These kinds of systems basically have a hardware and a software part. The hardware part consists of a sensor, signal conditioning, analog-to-digital converter, memory, processor, switches, digital-to-analog converter, etc. and the software part consist, of operating system, editor, graph display program and data processing software, etc..

A data acquisition system is used in various applications, starting from industry to scientific laboratories.

The actual definition of a data acquisition system also varies; here is a common definition of data acquisition system.

“Data acquisition is the process by which physical phenomena from the real world are transformed into electrical signals that are measured and converted into a digital format for processing, analysing, and storage by a computer”.

14.2

BASIC COMPONENTS OF DATA ACQUISITION SYSTEMS

The basic elements of a data acquisition system, as shown in the functional diagram ([Figure 14.1](#)) are as follows:

- Sensors and transducers
- Field wiring
- Signal conditioning
- Data acquisition hardware
- PC (operating system)
- Data acquisition software

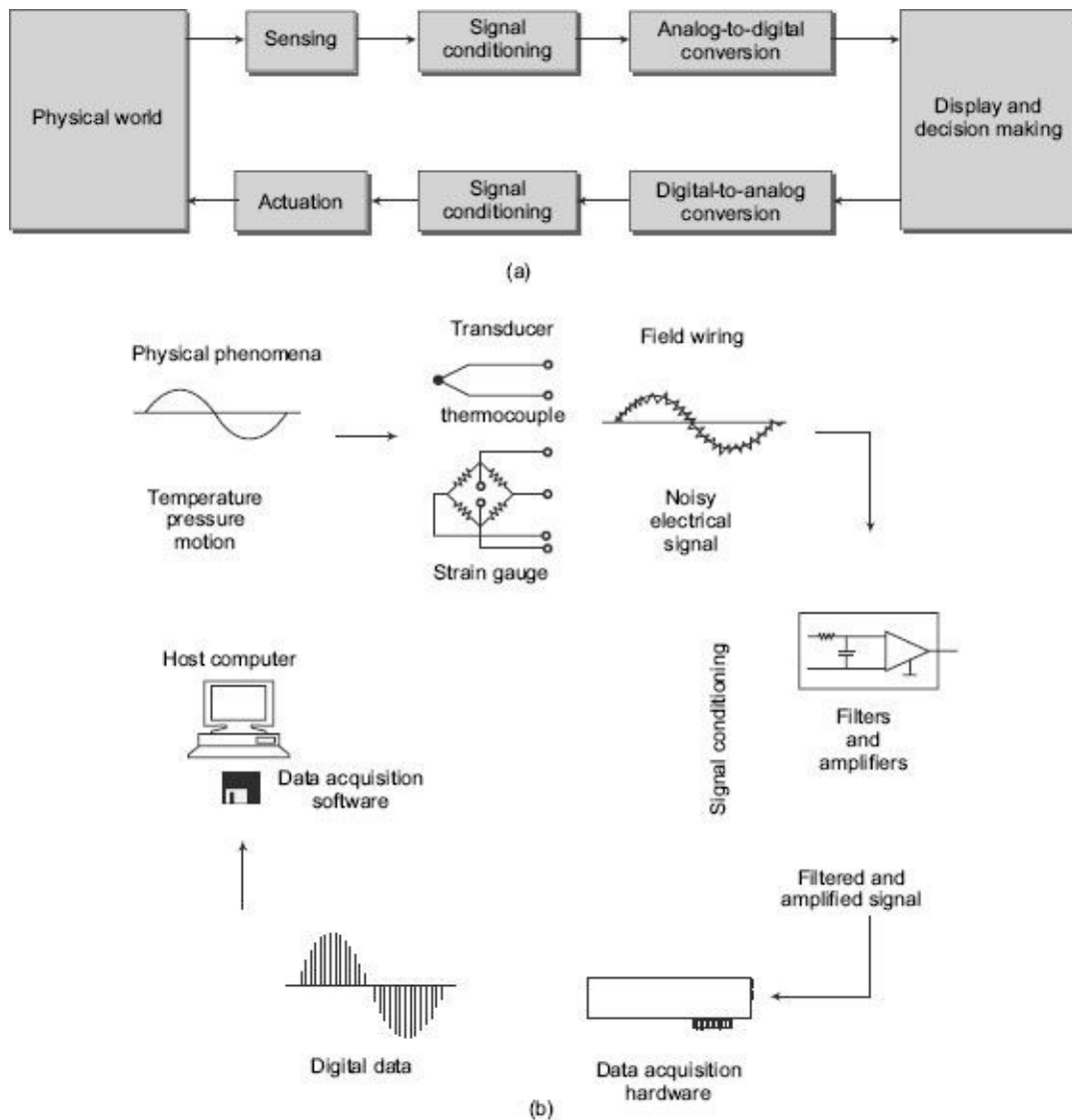

Figure 14.1 (a) and (b) Functional diagram of a data acquisition system

We can think of a data acquisition system as a collection of software and hardware that connects us to the physical world. A typical data acquisition system consists of these components.

Table 14.1 Components of a data acquisition system

Components	Description
Data acquisition hardware	The main function of this hardware is to convert analog signals to digital signals, and to convert processed digital signals to analog signals.
Sensors and actuators (transducers)	Transducer/Sensor converts input energy from one form to another form. For example, a thermocouple converts heat energy into electrical. An actuator also converts energy from one form to another, which is often connected at the output of a data acquisition system in order to manipulate the final control element.
Signal conditioning hardware	Sensor signals are often not compatible with data acquisition hardware. To overcome this incompatibility, the signal must be conditioned. For example, we may need to condition the thermocouple output signal by amplifying it or by removing unwanted frequency components. Output signals may also need conditioning.
Computer	The computer provides a processor, a system clock, a bus

	to transfer data, and memory and disk space to store data.
Software	It allows exchanging information between the computer and the hardware. For example, typical software allows us to configure the sampling rate of our board, and acquire a predefined amount of data.

14.3

COMPONENTS OF A TYPICAL PC-BASED DATA ACQUISITION SYSTEM

Earlier, expensive mainframe computers were used extensively for gathering multiple channels of data, primarily in large industrial or scientific applications. They were seldom used in small projects because of their relatively high cost. But the introduction of small rack-mounted minicomputers that developed in the 1960's and later desktop personal-type computers that housed microprocessors and proliferated in the 1970's justified their use for smaller projects. Soon, data acquisition plug-in cards (as well as hundreds of other types of plug-in cards) for these small computers were a common means to collect and record data of all types.

14.3.1 DAQ Hardware

A Data Acquisition System (DAQ) is a combination of computer hardware and software that gathers stores or processes data in order to control or monitor some sort of physical process. A typical data acquisition system comprises a computer system with DAQ hardware, wherein the DAQ hardware is typically plugged into one of the I/O slots of the computer system. The DAQ hardware is configured and controlled by DAQ software executing on the computer system. Data acquisition hardware is either internal and installed directly into an expansion slot inside your computer, or external and connected to your computer through an external cable, which is typically a USB cable.

At the simplest level, data acquisition hardware is characterised by the subsystems it possesses. A subsystem is a component of data acquisition hardware that performs a specialised task. Common subsystems include

- Analog input
- Analog output
- Digital input/output
- Counter/timer

Hardware devices that consist of multiple subsystems, such as the one depicted below, are called multifunction boards.

1. Analog Input Subsystems

Analog input subsystems convert real-world analog input signals from a sensor into bits that can be read by your computer. Perhaps the most important of all the subsystems commonly available, they are typically multichannel devices offering 12 or 16 bits of resolution.

Analog input subsystems are also referred to as AI subsystems, A/D converters, or

ADCs.

Analog-to-Digital Conversion In data acquisition systems, it is necessary to convert one or several analog signals into one or several digital signals capable of being stored in a digital memory and processed by a digital processor. Analog signals must be digitised before they can be used by a computer as a basis for supporting computations. An analog-to-digital converter is an electrical device that converts an analog signal to a digital signal. When the analog signal has been converted to a digital signal, it can be processed and stored by computer systems. An analog-to-digital converter is often fabricated on a single integrated circuit. The details of an analog input subsystem will be discussed in latter.

2. Analog Output Subsystems

Analog output subsystems convert digital data stored on your computer to a real-world analog signal. These subsystems perform the inverse conversion of analog input subsystems. Typical acquisition boards offer two output channels with 12 bits of resolution, with special hardware available to support multiple channel analog output operations.

Analog output subsystems are also referred to as AO subsystems, D/A converters, or DACs.

3. Digital Input/Output Subsystems

Digital input/output (DIO) subsystems are designed to input and output digital values (logic levels) to and from hardware. These values are typically handled either as single bits or lines, or as a port, which typically consists of eight lines.

While most popular data acquisition cards include some digital I/O capability, it is usually limited to simple operations, and special dedicated hardware is often necessary for performing advanced digital I/O operations.

4. Counter/Timers Subsystems

Counter/Timer subsystems are designed to count the number of pulses coming from external devices and the timers are normally used to provide strict time count of delay time

14.3.2 Sensors and Transducers

Transducer/Sensor converts input energy from one form to another form. According to the type, output sensors are classified in two types: digital sensors and analog sensors.

The sensors which can produce a digital output signal, that is a digital representation of the input signal, having discrete values of magnitude measured at discrete times, are called *digital sensors*. A digital sensor must output logic levels that are compatible with the digital receiver. Examples of digital sensors include switches and position encoders.

Analog sensors produce an output signal that is directly proportional to the input signal, and is continuous in both magnitude and in time. Most physical variables such as temperature, pressure and acceleration are continuous in nature and are readily measured with an analog sensor. For example, some common analog sensors and the physical variables they measure are listed below.

Table 14.2 Common analog sensors

Sensor	Physical Variable
Thermocouple	Temperature
Microphone	Pressure
Pressure gauge	Pressure
Photodiode	Light intensity
Strain gauge	Force
LVDT	Displacement

When choosing the best analog sensor to use, you must match the characteristics of the physical variable you are measuring with the characteristics of the sensor. The two most important sensor characteristics are

- The sensor output
- The sensor bandwidth

14.3.3 Signal Conditioning

Most sensors and transducers generate signals that must be conditioned before a measurement or DAQ device can reliably and accurately acquire the signal. This front-end processing is referred to as signal conditioning. A signal conditioner may create excitation for certain transducers such as strain gauges and resistance temperature detectors, which require external excitation voltages or currents. The main tasks performed by signal conditioning are as follows:

- Filtering
- Amplification
- Linearisation
- Isolation
- Excitation

Filtering

In noisy environments, it is very difficult to acquire low magnitude signals received from sensors such as signals from thermocouples and strain gauges (in the order of mV). If the noise is of the same or greater order of magnitude than the required signal, the noise must first be filtered out. Signal conditioning equipment often contain low-pass filters designed to eliminate high-frequency noise that can lead to inaccurate data.

Filtering is a process by which the unwanted noise frequencies are removed from the source signal. This is done before the signal is amplified to feed to the DAQ system.

Ideally, a filter should have a very sharp cut-off frequency, in order to separate the useful frequencies from the noise frequencies. However, most practical filters do not accurately attenuate the undesired frequencies beyond the desired range.

In general, analog filter hardware consists of two types of filters—namely active filters and passive filters.

While active filters use components like OP-AMPS, passive filters consist of passive components like capacitors, inductors and resistors. They provide cheap hardware for

filtering action. However, such filters are not ideal and they do not accurately attenuate the noise amplitudes.

In intelligent signal-conditioning modules, however, integrating A/D converters go a long way to averaging (filtering) out any cyclical noise appearing at the input.

Alternatively, software averaging may also be used to eliminate periodic system noises such as mains hum.

Filters have certain attributes which define them. They are as following:

1. Cut-off Frequency

It is the frequency beyond which the filter attenuates all the frequencies. It can be high-pass or low-pass cut-off frequency as required by the device. In general, cut-off frequency is considered as frequency where the normalised gain of the signal drops below 0.707 times the maximum gain.

2. Roll Off

This is the slope of the amplitude versus the frequency graph at the region of the cut-off frequency. This characteristic differentiates an ideal filter from a non-ideal filter.

3. Quality Factor

This factor determines the gain of the filter at the resonant frequency and the roll-off of the transfer characteristics on both sides of the resonant frequency.

Active filters are more frequently used as against the passive filters due to their sharper roll-off and better stability.

4. Types of Filters

There are four kinds of filters, namely

- Low-pass filter
- High-pass filter
- Band-pass filter
- Band-stop filter

(a) Low-Pass Filter A low-pass filter allows the low frequencies to pass while attenuates the higher frequencies. [Figure 14.2](#) shows the ideal low-pass filter characteristics, where ω_p is the filter cut-off frequency. [Figure 14.3](#) shows the circuit diagram of an active low-pass filter. The actual filter response deviates from the original when implemented. [Figure 14.4](#) shows the practical filter characteristics.

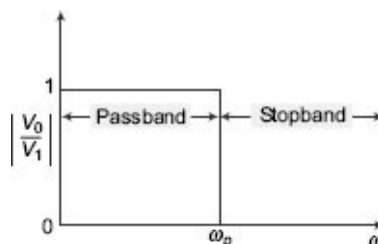

Figure 14.2 Ideal low-pass filter characteristics

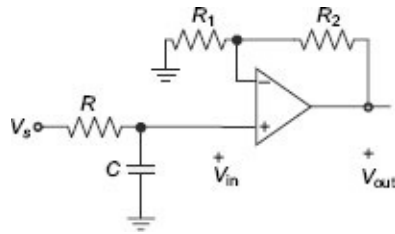

Figure 14.3 Circuit diagram of an active low-pass filter

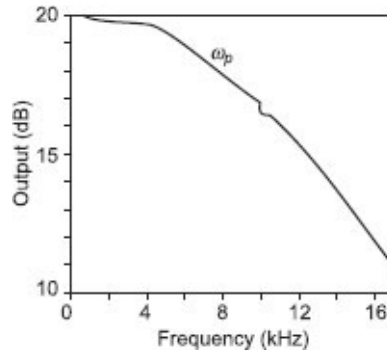

Figure 14.4 Practical low-pass filter characteristics

Figures 14.2 and 14.3 shows the circuit diagram and the transfer characteristics of a low-pass filter respectively. As we can see, a low-pass filter allows the low frequencies to pass while attenuates the higher frequencies.

(b) High-Pass Filter A high-pass filter allows the high frequencies to pass while attenuates the lower frequencies. Figure 14.5 shows the ideal high-pass filter characteristics, where ω_p is the filter cut-off frequency. Figure 14.6 shows the circuit diagram of an active high-pass filter. The actual filter response deviates from the original when implemented. Figure 14.7 shows the practical filter characteristics.

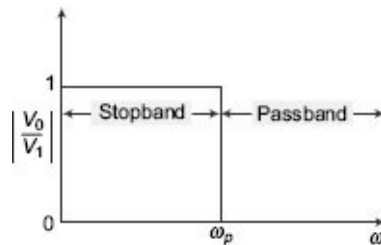

Figure 14.5 Ideal high-pass filter characteristics

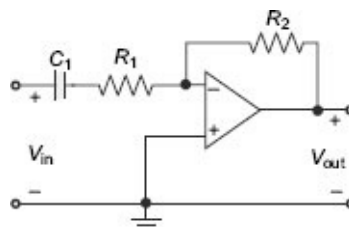

Figure 14.6 Circuit diagram of an active high-pass filter

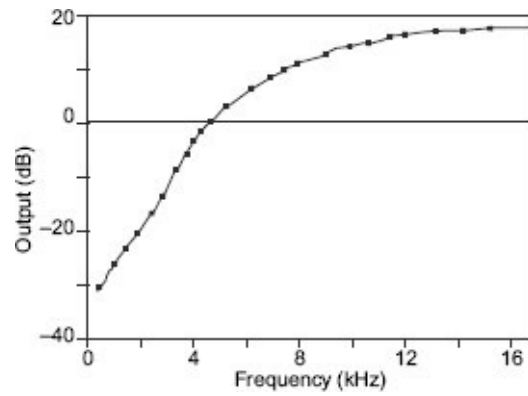

Figure 14.7 Practical high-pass filter characteristics

(c) Band-Pass (selective) Filter These are filters which allow frequencies within a certain range, bound by an upper (ω_{p2}) and a lower (ω_{p1}) cut-off frequency to pass through, attenuating other frequencies. These are also known as selective filters and they combine a low-pass and a high-pass filter in series to give selected band of frequency allowance. Figure 14.8 and 14.9 shows the characteristics of band-pass filter for an ideal and a real filter respectively.

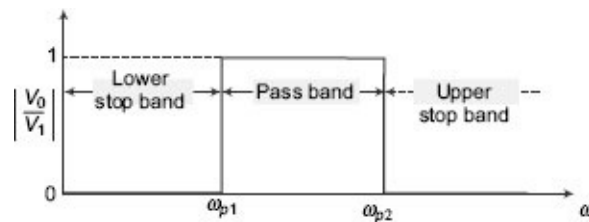

Figure 14.8 Ideal band-pass filter characteristics

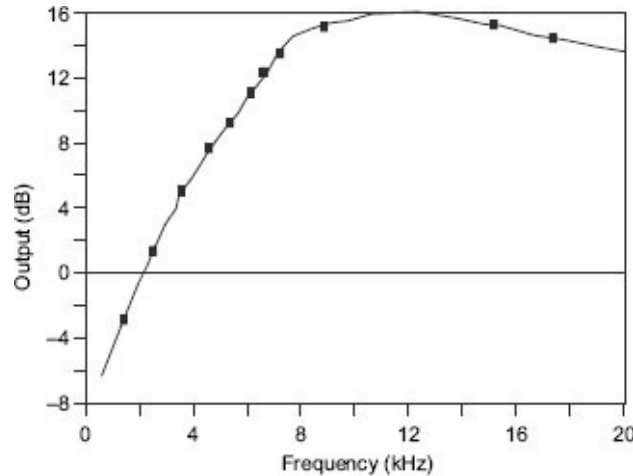

Figure 14.9 Practical band-pass filter characteristics

(d) Band-stop (Notch) Filters This kind of filter attenuates a certain band of frequencies and lets all other frequencies to pass through. They use a parallel combination of a high and low-pass filters to give the required attenuation of a band of frequencies. They are also known as notch. Figure 14.10 and 14.11 show the ideal and practical band-stop filter characteristics of a band-stop filter.

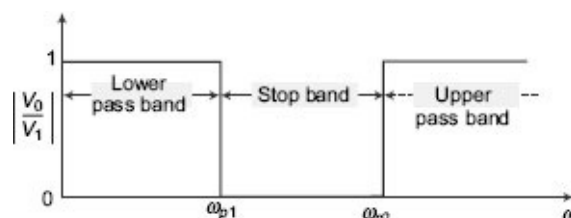

Figure 14.10 Ideal band-stop filter characteristics

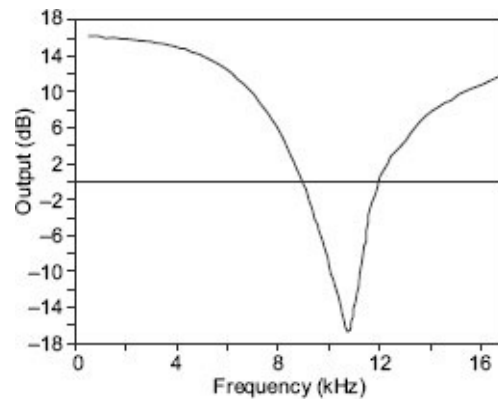

Figure 14.11 Ideal band-stop filter characteristics

(e) Butterworth Filter This is a kind of active filter which provides a better level of low-pass filtering. This is achieved by cascading two or more stages of low-pass filters. The number of stages of filtering determines how sharp the roll-off is at the cut-off frequency. [Figure 14.12](#) shows a two-stage Butterworth filter.

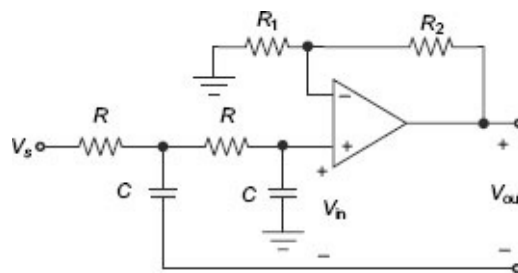

Figure 14.12 A two-stage Butterworth filter

5. Amplification

It is a process by which an input signal of weak signal strength (low amplitude) is converted into a signal of higher signal strength (high amplitude), so as to be readable by the processing devices.

In signal conditioning, amplification serves two main purposes:

- Increases resolution of the input signal
- Increases Signal-to-Noise ratio (SNR)

Amplification mainly serves for increasing resolution of the input signal. If, for example, a low-level signal of the order of a few mV is fed to a 12-bit ADC, there will be a loss of precision as the resolution of the ADC is of the order of 2 mV. However, if the signal is amplified to the order of 10 V (full scale voltage for ADC), we get the maximum precision. The highest possible resolution can be achieved by amplifying the input signal so that the maximum input voltage swing equals the maximum input range of the ADC.

Another important function of amplification is to achieve high signal-to-noise ratio. Amplifying a signal before sending it through a cable to the receiving end enables high SNR to the noises introduced in the path having noise interference. This ensures the improved precision of the measurement. If, however, the signal is amplified after the noise interference causes low SNR which implies the noise causes a considerable error in the input signal.

6. Linearisation

It is the modification of a system so that its outputs are approximately linear functions of its inputs, in order to facilitate analysis of the system.

It is seen that sometimes the data output by transducers bear a non-linear relationship with the measured phenomenon over a range of the measured variable. A good example of such relation is thermocouples. Such non-linear relationships need to be properly linearised for analysis of data. Typically, the DAQ software facilitates the linearisation of the signals. However, if the signal has a periodic and repeatable non-linear relation, an intelligent signal conditioning hardware may as well provide such linearisation. This however, requires the signal conditioning module to be modified for a particular type of transducer. The result then can be sent directly to the host PC directly without undergoing linearisation as the signal is directly related to the measured phenomenon

7. Isolation

Signal-conditioning equipment can also be used to provide isolation of transducer signals from the computer where there is a possibility that high-voltage transients may occur within the system being monitored, either due to electrostatic discharge or electrical failure. Isolation protects expensive computer equipment from damage and computer operators from injury. In addition, where common-mode voltage levels are high or there is a need for extremely low common-mode leakage current, as for medical applications, isolation allows measurements to be accurately and safely obtained.

Isolation in signal conditioning refers to the transmission signal from the source to measuring device without physical connection. The most common methods of circuit isolation include opto-isolation, magnetic or capacitive isolation. While opto-isolation is used for digital signals, magnetic and capacitive isolations are used for analog signals. Magnetic or capacitive isolation involves the modulation of the signal converting it from voltage to frequency signal and the transmitting it over a transformer or a capacitor, when it is again converted back to a voltage signal.

Isolation of the signal source is very crucial where there is a risk of high voltage transients caused by electrostatic discharge, lightning, or high-voltage equipment failure, which may ruin the expensive DAQ equipment if not isolated from the signal source and may also cause serious injuries to humans handling the equipment. Also using isolation prevents complexities caused by common-mode voltages and ground loops.

System isolation can be carried out in the following ways:

- By using isolation transformer in order to reject the common-mode voltage appearing on the signal lines
- By using buffer amplifiers to isolate the input signals from ground noise
- By isolating system ground references

8. Excitation

The transducers generally provide for the excitation signals required by the DAQ hardware and data manipulation. However, in some cases, the transducers require external excitation due to weak signal generation, non-electrical signal generation or due to noise interference and other factors. The signal-conditioning hardware provides for such excitation signals. The transducers which convert the non-electrical values into electrical

(voltage or current) signals are known as active transducers. These transducers do not generally require external excitation. Other devices known as passive transducers change an electrical network value, such as resistance, inductance or capacitance, according to changes in the physical quantity being measured. Strain gauges (resistive change to stress) and LVDTs (inductance change to displacement) are two examples of this. To be able to detect such changes, passive devices require external excitation.

14.3.4 The Computer

The PC used in a data acquisition system can greatly affect the speeds at which data can be continuously and accurately acquired, processed, and stored for a particular application. Where high-speed data acquisition is performed with a plug-in expansion board, the throughput provided by bus architectures, such as the PCI expansion bus, is higher than that delivered by the standard ISA or EISA expansion bus of the PC.

The particular application, the microprocessor speed, hard-disk access time, disk capacity and the types of data transfer available, can all have an impact on the speed at which the computer is able to continuously acquire data. All PCs, for example, are capable of programmed I/O and interrupt-driven data transfers. The use of Direct Memory Access (DMA), in which dedicated hardware is used to transfer data directly into the computer's memory, greatly increases the system throughput and leaves the computer's microprocessor free for other tasks. In normal operation, the data acquired, from a plug-in data acquisition board or other *DAQ hardware* (e.g. data logger), is stored directly to system memory. Where the available system memory exceeds the amount of data to be acquired, data can be transferred to permanent storage, such as a hard disk, at any time. The speed at which the data is transferred to permanent storage does not affect the overall throughput of the data acquisition system.

If real-time processing of the acquired data is needed, the performance of the computer's processor is paramount. A minimum requirement for high-frequency signals acquired at high sampling rates would be a 32-bit processor with its accompanying coprocessor, or alternatively a dedicated plug-in processor. Low frequency signals, for which only a few samples are processed each second, would obviously not require the same level of processing power. A low-end PC would, therefore, be satisfactory. Clearly, the performance requirements of the host computer must be matched to the specific application. As with all aspects of a data acquisition system, the choice of computer is a compromise between cost and the current and future requirements it must meet.

One final aspect of the personal computer that should be considered is the type of operating system installed. This may be single-tasking (e.g. MS-DOS) or multitasking (e.g. Windows 2000). While the multitasking nature of Windows provides many advantages for a wide range of applications, its use in data acquisition is not as clear.

The computer provides a processor, a system clock, a bus to transfer data, and memory and disk space to store data. The processor controls how fast data is accepted by the converter. The system clock provides time information about the acquired data. Data is transferred from the hardware to system memory via Dynamic Memory Access (DMA) or interrupts. DMA is hardware controlled and therefore extremely fast. Interrupts might be slow because of the latency time between when a board requests interrupt servicing and

when the computer responds. The maximum acquisition rate is also determined by the computer's bus architecture.

14.3.5 Software

Regardless of the hardware you are using, you must send information to the hardware and receive information from the hardware. You send configuration information to the hardware such as the sampling rate, and receive information from the hardware such as data, status messages, and error messages. You might also need to supply the hardware with information so that you can integrate it with other hardware and with computer resources. This information exchange is accomplished with software. There are two kinds of software:

- Driver software
- Application software

1. Driver Software

It allows us to access and control the capabilities of hardware. Among other things, basic driver software allows us to

- Bring data on to and get data off the board
- Control the rate at which data is acquired
- Integrate the data acquisition hardware with computer resources such as processor interrupts, DMA and memory
- Integrate the data acquisition hardware with signal-conditioning hardware
- Access multiple subsystems on a given data acquisition board
- Access multiple data acquisition boards

2. Application Software

It provides a convenient front end to the driver software. It allows us to

- Report relevant information such as the number of samples acquired
- Manage the data stored in computer memory
- Condition a signal
- Plot acquired data

14.4

ANALOG INPUT SUBSYSTEM

Many data acquisition hardware devices contain one or more subsystems that convert (digitise) real-world sensor signals into numbers which computers can read. Such devices are called analog input subsystems (AI subsystems, A/D converters, or ADCs). Analog input subsystems convert real-world analog input signals from a sensor into bits that can be read by our computer. Perhaps the most important of all the subsystems commonly available, they are typically multichannel devices offering 12 or 16 bits of resolution.

14.4.1 Nyquist Criterion

Analog signals are continuous in time and in amplitude (within predefined limits).

Sampling takes a “snapshot” of the signal at discrete times, while quantisation divides the voltage (or current) value into discrete amplitudes.

Sampling frequency has to be at least twice the frequency of the event that requires capture.

This rule is called the *Nyquist Criterion*. If one fails to follow this rule then a phenomenon called aliasing occurs. *Aliasing* is when a frequency higher than half of our sampling frequency gets “folded” back onto a frequency that is less than half of our sampling frequency. This creates a ghost signal that can really mess up our results.

14.4.2 A/D Conversion

A process of converting an analog signal into a digital signal comprises measuring the amplitude of the analog signal at consistent time intervals and producing a set of signals representing the measured digital value. The information in the digital signals and the known time interval enables one to convert the digital signal back to the analog signal. Analog to digital conversion of a continuous input signal normally occurs in two steps: *sampling* and *quantisation*. The sampler takes a time-varying analog input signal and converts it to a fixed voltage, current, electrical charge, or other output level. The quantiser takes the constant sampled level and compares it to the closest level from a discrete range of values called *quantisation levels*. The performance of analog and digital converters is typically quantified by two primary parameters, speed (in samples per second) and resolution (in bits). Higher resolution A/D converters typically require a large signal-to-noise ratio and good linearity. A/D converters with high sampling rates are frequently desired, but generally have lower resolution. There are two basic techniques for performing analog-to-digital conversion: an open-loop technique and a feedback technique.

14.4.3 Different Types of A/D Converters

While all analog-to-digital converters are classified by their resolution or number of bits, how the A/D circuitry achieves this resolution varies from device to device. There are four primary types of A/D converters used for industrial and laboratory applications:

- Successive approximation
- Flash/Parallel
- Integrating
- Ramp/Counting

Industrial and lab data acquisition tasks typically require 12 to 16 bits—12 are the most common. As a rule, increasing resolution results in higher costs and slower conversion speed.

Table 14.3 Comparison of different A/D converters

DESIGN	SPEED	RESOLUTION	NOISE IMMUNITY	COST
Successive approximation	Medium	10–16 bits	Poor	Low
Integrating	Slow	12–18 bits	Good	Low
Ramp/Counting	Slow	14–24 bits	Good	Medium
Flash/Parallel	Fast	4–8 bits	None	High

1. Successive Approximation

A successive approximation ADC is a type of analog-to-digital converter that converts a continuous analog waveform into a discrete digital representation via a binary search through all possible quantisation levels before finally converging upon a digital output for each conversion. It is the most common A/D converter design used for general industrial and laboratory applications (Figure 14.13). This design provides an effective compromise among resolution, speed, and cost. An internal digital-to-analog (D/A) converter and a single comparator—essentially a circuit determines which of two voltages is higher—are used to narrow in on the unknown voltage by turning bits in the D/A converter on until the voltages match to within the least significant bit.

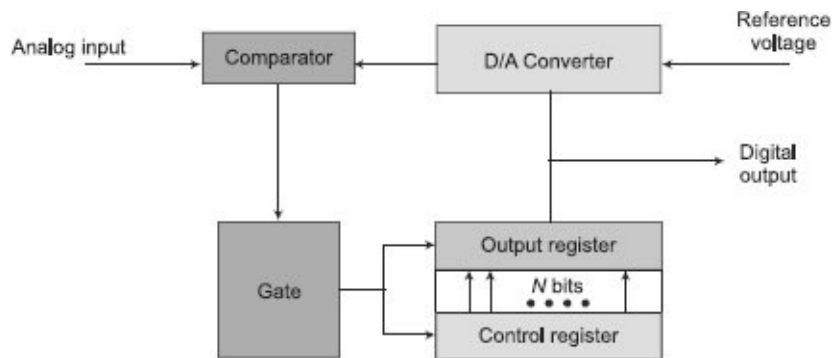

Figure 14.13 A/D conversion by successive approximation

2. Flash/Parallel

A flash A/D converter includes a reference voltage generator for generating a plurality of reference voltages, a first group of amplifiers having a plurality of amplifiers. Each of these amplifies a difference voltage between each reference voltage (generated by the reference voltage generator and a voltage of an input signal) and a second group of amplifiers having a plurality of amplifiers. It is used when higher speed operation is required. This design uses multiple comparators in parallel to process samples at more than 100 MHz with 8 to 12-bit resolution. Conversion is accomplished by a string of comparators with appropriate references operating in parallel (Figure 14.14).

The downside of this design is the large number of relatively expensive comparators that are required—for example; a 12-bit converter requires 4,095 comparators.

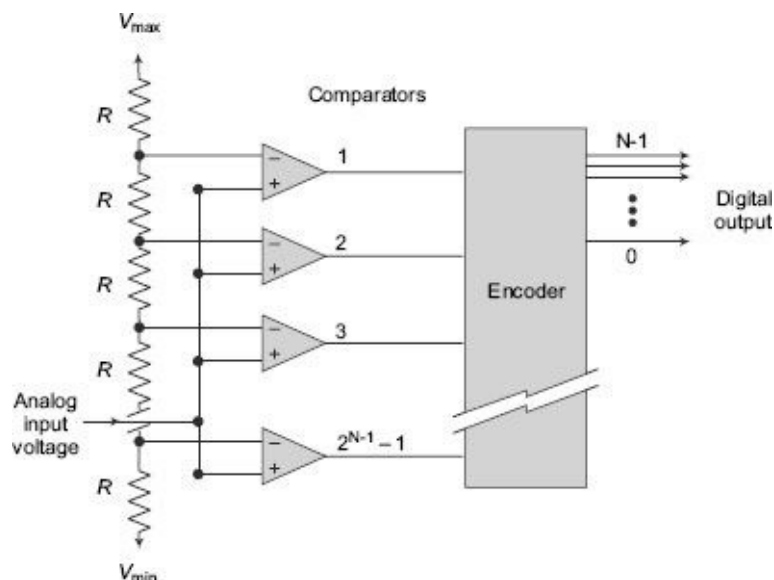

Figure 14.14 A/D Conversion by Flash/Parallel technique

3. Integrating

Integrating analog-to-digital converters (ADCs) provide high resolution and can provide good line frequency and noise rejection. This type of A/D converter integrates an unknown input voltage for a specific period of time and then integrates it back down to zero. This time is compared to the amount of time taken to perform a similar integration on a known reference voltage. The relative times required and the known reference voltage then yields the unknown input voltage. Integrating converters with 12 to 18-bit resolution are available, at raw sampling rates of 10–500 kHz. These types of converters often include built-in drivers for LCD or LED displays and are found in many portable instrument applications, including digital panel meters and digital multimeters.

It also smoothes out signal noise because this type of design effectively averages the input voltage over time. And, if an integration period is chosen that is a multiple of the ac line frequency, excellent common-mode noise rejection is achieved. More accurate and more linear than successive approximation converters, integrating converters are a good choice for low-level voltage signals.

4. Ramp/Counter

The flash (simultaneous) A/D converter uses several voltage comparators that compare reference voltages with the analog input voltage. These converters use one comparator circuit and a D/A converter (Figure 14.15). This design progressively increments a digital counter and with each new count generates the corresponding analog voltage and compares it to the unknown input voltage. When agreement is indicated, the counter contains the digital equivalent of the unknown signal. The advantage of this circuit is that it provides a faster method of analog-to-digital conversion.

A variation on the counter method is the ramp method, which substitutes an operational amplifier or other analog ramping circuit for the D/A converter. This technique is somewhat faster.

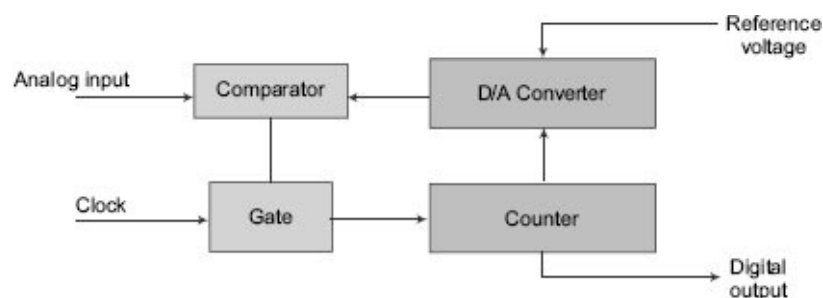

Figure 14.15 A/D Conversion by counting/ramp technique

14.4.3 Performance

Performance of a ADC is judged by obtaining following parameters:

1. Resolution

Central to the performance of an A/D converter is its resolution, often expressed in bits. An A/D converter essentially divides the analog input range into 2^N bits, where N is the number of bits. In other words, resolution is a measure of the number of levels used to

represent the analog input range and determines the converter's sensitivity to a change in analog input. Amplification of the signal, or input gain, can be used to increase the apparent sensitivity if the signal's expected maximum range is less than the input range of the A/D converter. As higher resolution A/D converters cost more, it is especially important to not buy more resolution than one needs—if one has 1% accurate (1 in 100) temperature transducers, a 16-bit (1 in 65,536) A/D converter has probably more resolution than one needs.

2. Voltage Stability

Absolute accuracy of the A/D conversion is a function of the reference voltage stability (the known voltage to which the unknown voltage is compared) as well as the comparator performance. Overall, it is of limited use to know the accuracy of the A/D converter itself. Accuracy of the system, together with the associated multiplexer, amplifier, and other circuitry is typically more meaningful.

3. Speed

The other primary A/D converter performance parameter that must be considered is speed-throughput for a multi-channel device. Overall, system speed depends on the conversion time, acquisition time, transfer time, and the number of channels being served by the system.

4. Acquisition

Acquisition is the time needed by the front-end analog circuitry to acquire a signal. Also called *aperture time*, it is the time for which the converter must see the analog voltage in order to complete a conversion. *Conversion* is the time needed to produce a digital value corresponding to the analog value. Transfer is the time needed to send the digital value to the host computer's memory. Throughput, then, equals the number of channels being served divided by the time required to do all three functions.

Example 14.1

An analog to digital converter (ADC) measures voltages in the range of 0 to 25 V and has 12-bit accuracy. What is the smallest voltage step that the ADC can resolve?

Solution $12 \text{ bits} = 2^{12} = 4096$

Therefore, the ADC can measure 4096 different values of voltage (from 0 to 4095 inclusive), the number of voltage steps is thus 4095 (one fewer than the number of different values available). Assuming that we set digital 0 to be equivalent to 0 V and digital 4095 to be equivalent to 25 V, each voltage step is simply given by

$$25 \text{ V}/4095 = 0.006105 \text{ V} = 6.105 \text{ mV}$$

Example 14.2

Determine the number of output bits required for an ADC so that quantising error less than 1 %.

Solution For 1 % quantising error, $\text{count} \geq 100$.

$$\text{For } n = 6, N = 2^6 - 1 = 63$$

For $n = 7$, $N = 2^7 - 1 = 127$

Example 14.3

A ramp-type ADC system uses a 10 MHz clock generator and a ramp voltage that increases from 0 V to 1.25 V in a time of 125 ms. Determine the number of clock pulses counted into the register when $V = 0.9$ V, and when it is 0.75 V.

Solution For $V_r = 1.25$ V, $t_r = 125$ ms

So for $V_i = 0.9$ V, $t_1 = \frac{t_r}{V_r} \times V_i = \frac{125 \text{ ms}}{1.25 \text{ V}} \times 0.9 \text{ V} = 90 \text{ ms}$

For the clock pulses, $T = \frac{1}{f} = \frac{1}{1 \text{ MHz}} = 1 \mu\text{s}$

Pulses counted, $N = \frac{t_1}{T} = \frac{90 \text{ ms}}{1 \mu\text{s}} = 900$

For $V_i = 0.75$ V, $t_1 = \frac{t_r}{V_r} \times V_i = \frac{125 \text{ ms}}{1.25 \text{ V}} \times 0.75 \text{ V} = 75 \text{ ms}$

Pulses counted, $N = \frac{t_1}{T} = \frac{75 \text{ ms}}{1 \mu\text{s}} = 750$

Example 14.4

If 3.45 V is applied to a 4-bit successive-approximation-type A/D converter which has a reference voltage of 5 V, what will be the digital output of the ADC?

- Set $d_3 = 1$, Output $5/2^1 = 2.5$ V.
 - Now, $3.45 > 2.5$ and set $d_3 = 1$
- Set $d_2 = 1$, Output $= 2.5 + \frac{5}{2^2} = 3.75$
 - Now, $3.45 < 3.75$ and set $d_2 = 0$
- Set $d_1 = 1$, Output $= 2.5 + \frac{5}{2^3} = 3.125$
 - Now, $3.125 < 3.45$ and set $d_1 = 1$
- Set $d_0 = 1$, Output $= 3.125 + \frac{5}{2^4} = 3.4375$
 - Now, $3.4375 < 3.45$ and set $d_0 = 1$.

Thus, the output of the A/D converter is 1011.

14.5

ANALOG OUTPUT SUBSYSTEM

Analog outputs commonly are used to operate final control elements in industrial environments like valves and motors. An analog output subsystem mainly consist of a Digital-to-Analog (D/A) converter, which is functionally opposite to an A/D converter. Similar to analog input configurations, a common D/A converter often is shared among multiplexed output signals. Standard analog output ranges are often same as analog input standards: ± 5 V dc, ± 10 V dc, 0–10 V dc, and 4–20 mA dc, etc.

1. Key Specifications of an Analog Output Subsystem

- (a) **Settling Time** Period required for a D/A converter to respond to a full-scale set point change.
- (b) **Linearity** This refers to the device's ability to accurately divide the reference voltage into evenly sized increments.
- (c) **Range** The reference voltage sets the limit on the output voltage achievable.

2. D/A Conversion

A digital-to-analog converter, or simply DAC, is a semiconductor device that is used to convert a digital code into an analog signal. Digital-to-analog conversion is the primary means by which digital equipment such as computer-based systems are able to translate digital data into real-world signals that are more understandable to or useable by humans, such as music, speech, pictures, video, and the like. It also allows digital control of machines, equipment, household appliances, and the like.

Essentially, the logic circuitry for an analog voltage output uses a digital word or series of bits, to drop in (or drop out, depending on whether the bit is 1 or 0) a series of resistors from a circuit driven by a reference voltage. This ladder of resistors can be made of either weighted-value resistors or an R - $2R$ network using only two resistor values—one if placed in series (Figure 14.16). While operation of the weighted-value network is more intuitively obvious, the R - $2R$ scheme is more practical. Because only one resistor value need be used, it is easier to match the temperature coefficients of an R - $2R$ ladder than a weighted network, resulting in more accurate outputs. Plus, for high resolution outputs, very high resistor values are needed in the weighted-resistor approach.

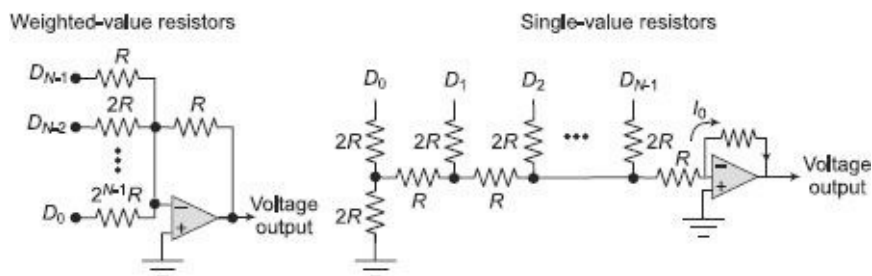

Figure 14.16 Weighted value and single-value resistor networks for D/A conversion

By the Nyquist–Shannon sampling theorem, sampled data can be reconstructed perfectly provided that its bandwidth meets certain requirements (e.g., a base-band signal with bandwidth less than the Nyquist frequency). However, even with an ideal reconstruction filter, digital sampling introduces quantisation error that makes perfect reconstruction practically impossible. Increasing the digital resolution (i.e., increasing the number of bits used in each sample) or introducing sampling dither can reduce this error.

14.5.1 Different Types of DACs

The most common types of electronic DACs are the following:

1. Pulse Width Modulator

It is the simplest DAC type. A stable current or voltage is switched into a low-pass analog filter with a duration determined by the digital input code. This technique is often used for

electric motor speed control, and is now becoming common in high-fidelity audio.

2. Oversampling DACs or Interpolating DACs

They use a pulse density conversion technique. The oversampling technique allows for the use of a lower resolution DAC internally. A simple 1-bit DAC is often chosen because the oversampled result is inherently linear. The DAC is driven with a pulse density modulated signal, created with the use of a low-pass filter, step nonlinearity (the actual 1-bit DAC), and negative feedback loop, in a technique called *delta-sigma modulation*. This results in an effective high-pass filter acting on the quantisation (signal processing) noise, thus steering this noise out of the low frequencies of interest into the high frequencies of little interest, which is called *noise shaping* (very high frequencies because of the over sampling). The quantisation noise at these high frequencies are removed or greatly attenuated by use of an analog low-pass filter at the output (sometimes a simple RC low-pass circuit is sufficient). Most very-high-resolution DACs (greater than 16 bits) are of this type due to high linearity and low cost. Higher oversampling rates can relax the specifications of the output low-pass filter and enable further suppression of quantisation noise. Speeds of greater than 100 thousand samples per second (for example, 192 kHz) and resolutions of 24 bits are attainable with Delta-Sigma DACs.

3. Binary Weighted DAC

It contains one resistor or current source for each bit of the DAC connected to a summing point. These precise voltages or currents sum to the correct output value. This is one of the fastest conversion methods but suffers from poor accuracy because of the high precision required for each individual voltage or current. Such high-precision resistors and current sources are expensive, so this type of converter is usually limited to 8-bit resolution or less.

4. R-2R Ladder DAC

It is a binary weighted DAC that uses a repeating cascaded structure of resistor values R and $2R$ as shown in [Figure 14.17](#). This improves the precision due to the relative ease of producing equal-valued matched resistors (or current sources). However, wide converters perform slowly due to increasingly large RC -constants for each added R - $2R$ link.

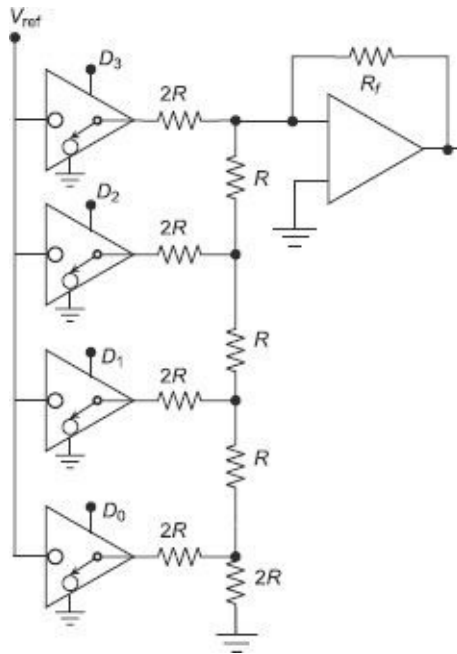

Figure 14.17 R-2R ladder DAC

5. Thermometer Coded DAC

It contains an equal resistor or current source segment for each possible value of DAC output. An 8-bit thermometer DAC would have 255 segments, and a 16-bit thermometer DAC would have 65,535 segments. This is perhaps the fastest and highest precision DAC architecture but at the expense of high cost. Conversion speeds of >1 billion samples per second have been reached with this type of DAC.

6. Hybrid DAC

It uses a combination of the above techniques in a single converter. Most DAC integrated circuits are of this type due to the difficulty of getting low cost, high speed and high precision in one device.

14.5.2 DAC Performance

DACs are at the beginning of the analog signal chain, which makes them very important to system performance. The most important characteristics of these devices are the following:

1. Resolution

This is the number of possible output levels the DAC is designed to reproduce. This is usually stated as the number of bits it uses, which is the base two logarithm of the number of levels. For instance, a 1 bit DAC is designed to reproduce 2 (2^1) levels while an 8 bit DAC is designed for 256 (2^8) levels. Resolution is related to the Effective Number of Bits (ENOB) which is a measurement of the actual resolution attained by the DAC.

2. Maximum Sampling Frequency

This is a measurement of the maximum speed at which the DACs circuitry can operate and still produce the correct output. As stated in the Nyquist–Shannon sampling theorem, a signal must be sampled at over twice the frequency of the desired signal. For instance, to reproduce signals in all the audible spectrum, which includes frequencies of up to 20 kHz,

it is necessary to use DACs that operate at over 40 kHz. The CD standard samples audio at 44.1 kHz, thus, DACs of this frequency are often used. A common frequency in cheap computer sound cards is 48 kHz — many work at only this frequency, offering the use of other sample rates only through (often poor) internal resampling.

3. Monotonicity

This refers to the ability of DAC's analog output to increase with an increase in digital code or the converse. This characteristic is very important for DACs used as a low-frequency signal source or as a digitally programmable trim element.

4. THD+N

This is a measurement of the distortion and noise introduced to the signal by the DAC. It is expressed as a percentage of the total power of unwanted harmonic distortion and noise that accompany the desired signal. This is a very important DAC characteristic for dynamic and small-signal DAC applications.

5. Dynamic Range

This is a measurement of the difference between the largest and smallest signals the DAC can reproduce expressed in decibels. This is usually related to DAC resolution and noise floor.

Example 14.5

Given a 3-bit DAC with a 1 V full-scale voltage and accuracy $\pm 0.2\%$, find its resolution and accuracy in terms of voltage.

Solution Resolution $= 1/2^3 = 0.125 \text{ V}$
 Accuracy $= (\pm 0.2\%) \times (1\text{V}) = \pm 2 \text{ mV}$

Example 14.6

An 8-bit D/A converter has $+V_{ref} = 5 \text{ V}$ and $-V_{ref} = 0 \text{ V}$ (Reference voltages). What is the output voltage when $B_{in} = 10110100$? Find also V_{LSB} .

Solution

$$B_{in} = 2^{-1} + 2^{-3} + 2^{-4} + 2^{-6} = 0.703125$$

$$V_{out} = \Delta V_{ref} B_{in} = 5 * 0.703125 = 3.516 \text{ V}$$

$$V_{LSB} = \frac{5}{2^8} = \frac{5}{256} = 19.5 \text{ mV}$$

Example 14.7

A 6-bit D/A converter has a reference voltage of 10 V. Calculate the minimum value of R such that the maximum value of output current does not exceed 10 mA. Find also the smallest quantised value of output current.

Solution

Maximum output current	$I_{\max} = \frac{E_R(2^n - 1)}{2^{n-2} R}$
The minimum value of	$R = \frac{E_R \times (2^n - 1)}{2^{n-2}} \times \frac{1}{I_{\max}}$
	$= \frac{10 \times (2^6 - 1)}{2^5} \times \frac{1}{10 \times 10^{-3}} = 1969 \Omega$
Current with LSB	$= \frac{E_R}{2^{n-1} R} = \frac{10}{2^5 \times 2000} = 156 \mu\text{A}$

Example 14.8

A 6-bit D/A converter having 320 kΩ resistances is in LSB position. The converter is designed with weighted resistive network. The reference voltage is 10 V. The output of the resistive network is connected to an OP-AMP with a feedback resistance of 5 kΩ. What is the output voltage for a binary input of 111.010?

Solution

Output current	$I_0 = \frac{E_R}{R} \left[d_{n-1} + \frac{d_{n-2}}{2} + \dots + \frac{d_1}{2^{n-2}} + \frac{d_0}{2^{n-1}} \right]$
As	$n = 6$
So, resistance in LSB	$= 2^{n-1} R = 2^5 R = 320 \text{ k}\Omega \text{ or } R = 10 \text{ k}\Omega$
Hence, output current	$= \frac{10}{10 \times 10^3} \left[1 \times 1 + 1 \times \frac{1}{2} + 1 \times \frac{1}{4} + 0 \times \frac{1}{8} + 1 \times \frac{1}{16} + 0 \times \frac{1}{32} \right]$
	$= 1.8125 \text{ mA}$
Therefore, output voltage	$E_0 = I_0 R_f = -1.8125 \times 10^{-3} \times 5 \times 10^3 = -9 \text{ V}$

14.6

DIGITAL INPUT AND OUTPUT SUBSYSTEM

We saw that analog transducers sense continuous variables such as pressure and temperature and send the output in a continuous form to the ADC (analog to digital converter) via a signal conditioning device. In contrast to that, many transducers provide an output that is one of two states: high or low, open or closed, on or off, etc. For example, pressure might be too high or a temperature too low, triggering closure of a switch. This kind of input which is provided to the computer by the transducer is known as the *digital input*.

Outputs, too, are not always strictly analog. For example, solenoid valves typically are opened or closed; many pumps and heaters are simply turned on or off. The output of a printer is also purely digital in nature.

Digital I/O interfaces are commonly used in PC based DAQ systems to provide monitoring and control for industrial processes, generate patterns for testing in the laboratory and communicate with peripheral equipment such as data loggers and printers which have parallel digital I/O capabilities.

It is clear that these types of digital, or discrete, inputs and outputs (I/O) are much easier for microprocessor-based data acquisition systems to deal with than analog signals as the computer has a fully binary environment. Similar to analog-to-digital converters used for

analog I/O, digital I/O is designed to deal directly with Transistor-to-Transistor Logic (TTL) level voltage changes. TTL typically sets the low-voltage level between 0 and 0.8 V and the high-voltage level between 2.0 and 5.0 V. Voltage levels between 0.8 and 2.0 V are not allowed. A voltage change, then, from the high range to the low range (or vice versa) represents a digital change of state from high to low, on to off, etc. and because acquiring an analog signal is more complex than acquiring a digital one, analog I/O channels also are more expensive. A clear comparison of the complexity in acquiring a signal in analog and digital forms is shown in Figure 18.

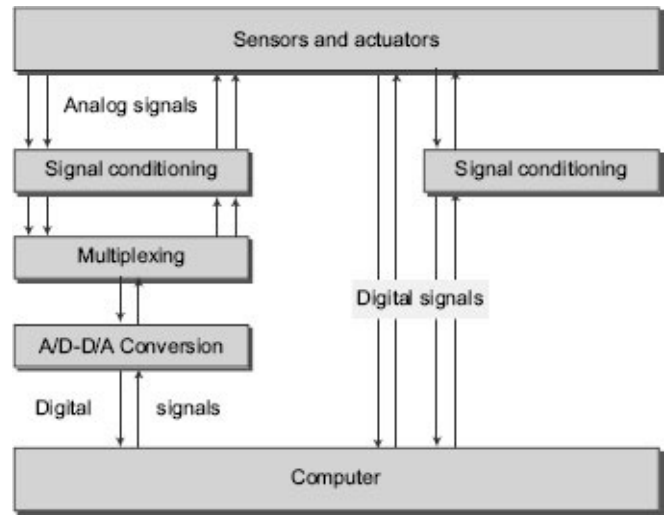

Figure 14.18 Comparison of digital and analog input

14.6.1 Digital Inputs

Many types of digital input signals from switch closures, relay contacts, or TTL compatible interfaces can be read directly by digital I/O cards (Figure 14.18). Other types of inputs may require some signal-conditioning, most likely to reduce higher level voltage changes to TTL levels. A variety of signal-conditioning modules are available to provide isolation and other digital-conditioning functions. The most common type of digital input is the contact closure (Figure 14.19). Essentially, a sensor or switch of some type closes or opens a set of contacts in accordance with some process change. An applied electrical signal then determines whether the circuit is open or closed. Current flows if the circuit is closed, registering a “1” in a transistor at the computer interface. Conversely, an open circuit retains a high voltage (and no current), registering a “0” at the transistor.

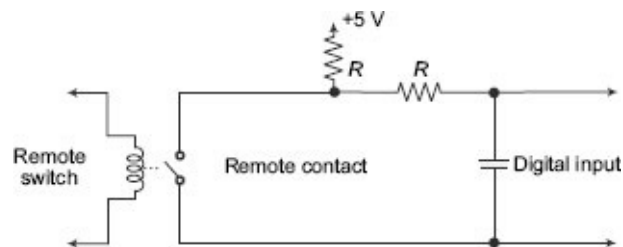

Figure 14.19 Contact type digital input

14.6.2 Digital Outputs

At its simplest, a digital output provides a means of turning something on or off. Applications range from driving a relay to turning on an indicator lamp to transmitting data to another computer. For latching outputs, a “1” typically causes the associated switch or relay to latch, while a “0” causes the switch to unlatch. Devices can be turned on or off,

depending on whether the external contacts are normally open or normally closed. Standard TTL level signals can be used to drive 5 V relay coils; a protective diode is used to protect the digital output circuitry (Figure 14.20). Because data acquisition boards can typically supply only 24 mA of driving current, they are intended primarily to drive other logic circuits, not final control elements. Scaling may be needed so that logical voltage levels are sufficient to cause switching in larger relays. Outputs intended to drive larger solenoids, contactors, motors, or alarms also may require a boost.

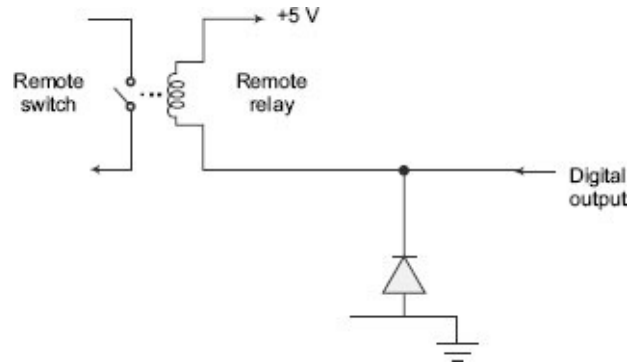

Figure 14.20 Contact type digital input

14.6.3 Counter/Timer and Pulse I/O

A somewhat separate class of digital I/O is pulse inputs and outputs, which typically is associated with frequency, counting or totalisation applications. Pulse inputs might be used to count the rotations of a turbine flowmeter; pulse outputs might be used to drive a stepping motor.

Pulse inputs are handled in much the same way as digital logic inputs, but the output of the sensing circuit is normally connected to a counter rather than a specific bit position in the input register. Successive pulses increment or decrement the counter. Add an elapsed time measure and a frequency or pulse rate can readily be determined. Similar to an analog-to-digital converter, a counter is characterised by its number of bits—an N -bit counter can accumulate up to $2N$ discrete events. Thus, a 16-bit counter can count to $2^{16} = 65,536$.

14.7

IEEE 488 INTERFACE

In 1965, Hewlett-Packard designed the Hewlett-Packard Interface Bus (HP-IB) to connect programmable instruments with computers. A high transfer rate around 1 Mbytes/second was possible to realise and due to this high transfer rate, this interface bus quickly gained popularity. It was later accepted as IEEE Standard 488-1975, and has evolved to ANSI/IEEE Standard 488.1-1987. Today, the name General Purpose Interface Bus (GPIB) is more widely used than HP-IB. ANSI/IEEE 488.2-1987 strengthened the original standard by defining precisely how controllers and instruments communicate.

Up to 15 devices can be connected in a single IEEE 488 bus by daisy-chaining. The speed is determined by the slowest device participating in the control and data-transfer handshakes. The GPIB bus is an 8-bit wide parallel interface system. The bus consists of 5

control lines, 3 handshake lines, 8 bi-directional data lines. It has a total of 24 lines, with the remaining lines occupied by ground wires. Additional features include TTL logic levels (negative true logic). It has the ability to communicate in a number of different language formats, and no minimum operational transfer limit. The maximum data-transfer rate is determined by a number of factors, often it is realised in 1 Mb/s.

Devices connected in the bus can be classified in the following category:

1. Controller
2. Talker
3. Listener

Figure 14.21 shows the connection of these three types of devices.

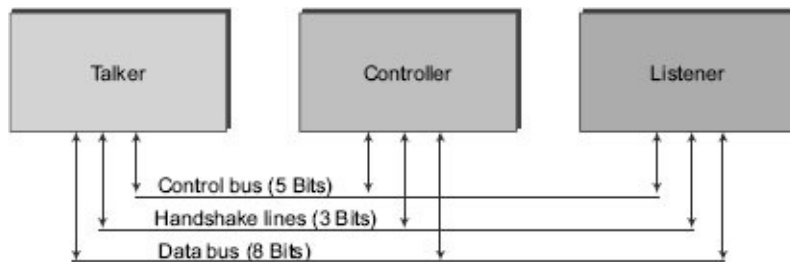

Figure 14.21 Connection diagram of different devices with IEEE GPIB bus

A single device connected can have all the three or any two or at least any one of these features, but only one option will be active at a time. The first function of the bus controller (which is only one at a time) is to determine which device is active on the bus. There may be many numbers of active listeners existing on the bus with an active talker as long as no more than 15 devices are connected to the bus. The controller sends interface messages over the bus to a particular active instrument. Each individual device is associated with a unique 5-bit BCD code (ID number). By using this code, the controller can coordinate the activities on the bus and the individual devices can be made to talk, listen (un-talk, unlisten) as determined by the controller.

1. Data Lines

The eight data lines, DIO1 through DIO8, carry both data and command messages. The state of the Attention (ATN) line determines whether the information is data or commands. All commands and most data use the 7-bit ASCII or ISO code set, in which case the eighth bit, DIO8, is either unused or used for parity.

2. Handshake Lines

Three lines asynchronously control the transfer of message bytes between devices. The process is called a 3-wire interlocked handshake. It guarantees that message bytes on the data lines are sent and received without transmission error.

(a) NRD (Not Ready For Data) This indicates when a device is ready or not ready to receive a message byte. The line is driven by all devices when receiving commands, by Listeners when receiving data messages, and by the Talker when enabling the HS488 protocol.

(b) NDAC (Not Data Accepted) This indicates when a device has or has not accepted a message byte. The line is driven by all devices when receiving commands, and by listeners when receiving data messages.

(c) **DAV (Data Valid)** This tells when the signals on the data lines are stable (valid) and can be accepted safely by devices. The Controller drives DAV when sending commands, and the Talker drives DAV when sending data messages.

3. Interface Management Lines

Five lines manage the flow of information across the interface:

(a) **ATN (Attention)** The Controller drives ATN true when it uses the data lines to send commands, and drives ATN false when a Talker can send data messages.

(b) **IFC (Interface Clear)** The System Controller drives the IFC line to initialise the bus and become CIC.

(c) **REN (Remote Enable)** The System Controller drives the REN line, which is used to place devices in remote or local program mode.

(d) **SRQ (Service Request)** Any device can drive the SRQ line to asynchronously request service from the Controller.

(e) **EOI (End or Identify)** The EOI line has two purposes—the Talker uses the EOI line to mark the end of a message string, and the Controller uses the EOI line to tell devices to identify their response in a parallel poll.

Figure 14.22 Pin-out description of GPIB bus

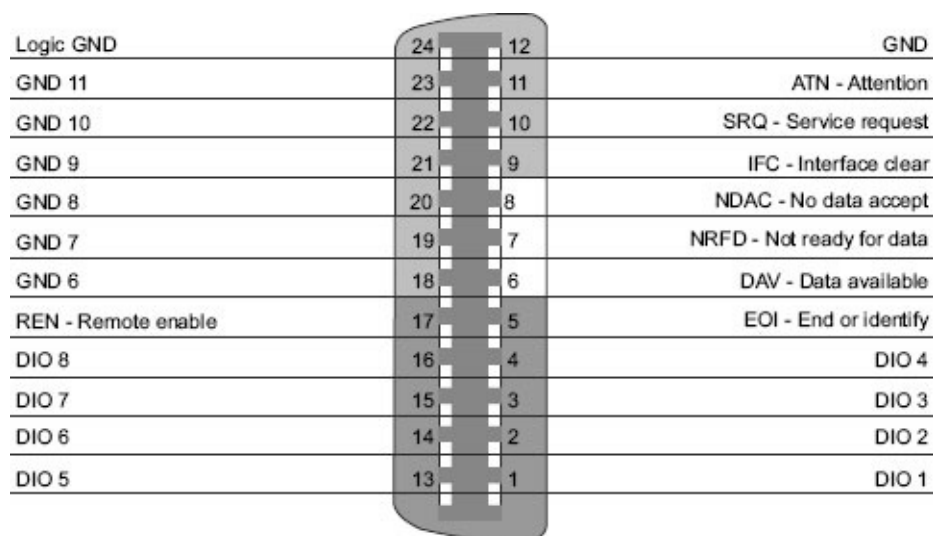

Figure 14.22 pin-out description of GPIB bus

4. GPIB Data Transfer Operation

The three lines (DAV, NRFD and NDAC) are used to form three handshake lines which control the passage of data. The active talker controls the ‘DAV’ line (Data Valid) and the listener(s) control the ‘NRFD’ (Not Ready For Data), and the ‘NDAC’ (Not Data Accepted) line. In the steady state mode, the Talker hold ‘DAV’ high (no data available) while the listener hold ‘NRFD’ high (ready for data) and ‘NDAC’ low (no data accepted). After the talker placed data on the bus it then takes ‘DAV’ low (data valid). The Listener(s) then send ‘NRFD’ low and send ‘NDAC’ high (data accepted). Before the Talker lifts the data off the bus, ‘DAV’ is taken high signifying that data is no longer valid. If the ‘ATN’ line (attention) is high while this process occurs, the information is considered data but with the “ATN’ line low, the information is regarded as an interface

message. The other five lines on the bus ('ATN' included) are the bus-management lines. These lines enable the Controller and other devices on the bus to enable, interrupt, flag, and halt the operation of the bus.

All lines in the GPIB are tri-state except for 'SQR', 'NRFD', and 'NDAC' which are open-collector. The standard bus termination is a 3K resistor connected to 5 volts in series with a 6.2K resistor to ground — all values having a 5% tolerance.

The standard also allows for identification of the devices on the bus. Each device should have a string of 1 or 2 letters placed somewhere on the body of the device (near or on the GPIB connector). These letters signify the capabilities of the device on the GPIB bus.

Table 14.4 *Device capabilities on the GPIB bus*

C	Controller
T	Talker
L	Listener
AH	Acceptor Handshake
SH	Source Handshake
DC	Device Clear
DT	Device Trigger
RL	Remote Local
PP	Parallel Poll
TE	Talker Extended
LE	Listener Extended

Devices are connected together on the bus in a daisy-chained fashion. Normally, the GPIB connector (after being connected to the device with the male side) has a female interface so that another connector may be attached to it. This allows the devices to be daisy chained. Devices are connected together in either a linear or star fashion.

EXERCISE

Objective-type Questions

1. The function of data acquisition system is
 - (a) acquiring physical phenomena from the real world
 - (b) sending signal to real world
 - (c) processing and analysing of signal
 - (d) all of the above
2. Identify the element which is not part of a data acquisition system:
 - (a) Digital to analog converter
 - (b) Filter
 - (c) Display
 - (d) Timer
3. Which A/D converter has highest conversion time?
 - (a) Flash type

- (b) Dual slope integrating
 - (c) Successive approximation
 - (d) Ramp/Counting
4. How many devices can be connected in a single IEEE 488 bus?
- (a) 15
 - (b) 16
 - (c) 32
 - (d) Infinite
5. A signal has minimum and maximum values of -5 V and $+5\text{ V}$ respectively. To record a 0.01 V change of the signal value, what bit length of A/D converter is required?
- (a) 4 bit
 - (b) 8 bit
 - (c) 10 bit
 - (d) None of these
6. The function of notch filter is
- (a) pass high frequency signal
 - (b) pass a particular band of signal
 - (c) pass low frequency signal
 - (d) none of these
7. If a signal has a bandwidth of 20 Hz to 20 kHz , what will be the minimum sampling frequency to acquire the signal so that the signal can be reproduced properly?
- (a) 20 Hz
 - (b) $> 20\text{ Hz}$ but $< 20\text{ kHz}$
 - (c) $< 20\text{ kHz}$
 - (d) $> 20\text{ kHz}$
8. The correct TTL logic levels are
- (a) $0\text{--}0.8\text{ V}$ and $2.0\text{--}5.0\text{ V}$
 - (b) $0\text{--}0.4\text{ V}$ and $2.4\text{--}5.0\text{ V}$
 - (c) 0 V and 5 V
 - (d) $0\text{--}0.1\text{ V}$ and $4.9\text{--}5.0\text{ V}$
9. An IEEE 488 bus contains
- (a) 8 data lines and 1 Address lines
 - (b) 5 control lines, 3 handshake lines and 8 data lines
 - (c) 3 control lines, 5 handshake lines and 8 data lines
 - (d) 5 control lines, 3 handshake lines, 8 data lines and 4 address lines
10. Which may not be the feature of a data acquisition application software?
- (a) Manage the data stored in computer memory
 - (b) Plot acquired data
 - (c) Report relevant information such as the number of samples acquired
 - (d) Acquire data from real world

Answers

- | | | | | | | |
|--------|--------|---------|--------|--------|--------|--------|
| 1. (d) | 2. (c) | 3. (b) | 4. (a) | 5. (c) | 6. (d) | 7. (d) |
| 8. (a) | 9. (b) | 10. (d) | | | | |

Short-answer Questions

1. Define a data acquisition system and draw the functional block diagram of a typical DAQ.
2. What are the different components of a DAQ? Briefly discuss those.
3. What are the different signal-conditioning units a data acquisition system contains? Briefly discuss those.
4. What are the different processes for isolation of field instrument from DAQ hardware?
5. State the different functions of driver software of a typical DAQ system.
6. Compare successive approximation, flash, integrating and ramp ADC.
7. Compare $R-2R$ DAC with a binary weighted DAC.
8. How are the digital input and output system connected with digital I/O pins of DAQ hardware?
9. How do the devices connected with IEEE 488 bus communicate with each other?
10. Write down the different functions of 5 control signals of IEEE 488 bus.

Long-answer Questions

1. An 8-bit ADC is converting a temperature signal which has a measuring range of 0 deg C to 800 deg C. Calculate the resolution of the temperature-measuring instrument.
2. Suppose a 10-bit ADC has $+V_{\text{ref}}$ and $-V_{\text{ref}}$ of +5 V and -5 V respectively. If the ADC is being used to convert a signal having minimum and maximum value of -1 V and +1 V then what amount of smallest voltage change can the ADC distinguish?
3. A ramp-type ADC system uses a 20 MHz clock generator and a ramp voltage that increases from 0 V to 5 V in a time of 0.5 sec. Determine the number of clock pulses counted into the register when $V = 1$ V, and when it is 2.5 V.
4. A 4-bit D/A converter has 320 kW resistances in LSB position. The converter is designed with weighted resistive network. The reference voltage is +5 V. The output of the resistive network is connected to an OP-AMP with a feedback resistance of 5 kW. What is the output voltage for a binary input of 101.110?
5. An 8-bit D/A converter has $-V_{\text{ref}} = -5$ V and $+V_{\text{ref}} = +5$ V respectively. Then calculate the output voltage when an input of 140_{10} (decimal) is given in the input of DAC. Also, find the V_{LSB} .

After collecting information about the state of some process, the next consideration is how to present it in a form where it can be readily used and analysed. This chapter, therefore, starts by covering the techniques available to either display measurement data for current use or record it for future use. Following this, standards of good practice for presenting data in either graphical or tabular form are covered, using either paper or a computer monitor screen as the display medium.

Nowadays, a wide variety of recorders are used in industry, laboratory and various fields. Covering all these in a chapter is a formidable task. An attempt has therefore been made to classify the more common types of chart recorders. The definition of a chart recorder is “*a device for producing, as a permanent record in analog form, the change of a variable signal (x) against time (t) (whether this be continuous or intermittent)*”. In this section, only electrically actuated recorders will be considered, although in many applications, such as the recording of pressure, mechanically actuated devices are used. However, with the increasing requirement for display as well as recording at a remote central point, where the information is also required to be passed for data processing, there is a greater tendency nowadays to use electrical methods employing suitable transducers.

Many techniques now exist for recording measurement data in a form that permits subsequent analysis, particularly for looking at the historical behaviour of measured parameters in fault diagnosis procedures. The earliest recording instruments used were various forms of mechanical chart recorders. Whilst many of these remain in use, most modern forms of chart recorder exist in hybrid forms in which microprocessors are incorporated to improve performance. The sections below discuss these, along with other methods of recording signals including digital recorders, magnetic tape recorders, digital (storage) oscilloscopes and hard-copy devices such as dot-matrix, inkjet and laser printers, X-Y recorders, ultraviolet recorders and thermal array recorders.

Classification of Recorders

There are many ways for classifying recorders; the popular one is according to the type of signal to be recorded, which is as follows:

1. Analog recorders
 - a. Graphic recorder
 - i. Strip chart recorder
 - Galvanometer type

- Null type
 - Potentiometric recorders
 - Bridge recorders
 - LVDT recorders
 - ii. Circular chart recorders
 - iii. X-Y Recorders
 - b. Magnetic tape recorders
 - c. Oscillographic recorders
 - d. Others [hybrid, paperless, ultraviolet and thermal dot matrix recorder]
2. Digital recorders

15.2

ANALOG RECORDERS

These kinds of recorders are used to record analog signals in the form of a chart paper for keeping the record permanently. Despite the present emphasis by the electronics industry on digital instrumentation, the use of analog recorders is still popular. As they present an instantaneous visual indication of the data being recorded, they do it in an analog way, which is often more meaningful than digital indication to people in the laboratory or on the production line. There are basically three types of analog recorders available: graphic, oscillographic and magnetic tape recorders.

15.2.1 Graphic Recorders

A graphic recorder is basically a measuring device which is able to produce in real time a hard copy of a set of time functions with the purpose of immediate and/or later visual inspection. The curves/lines are mostly drawn on a (long) strip of paper (from a roll), often called strip chart recorder. When the curves are drawn on a circular paper, it is called a *circular chart recorder*, and when two independent variables are to be recorded on a piece of paper with respect to each other, it is called an X-Y recorder.

1. Strip Chart Recorder

A strip chart recorder records physical variable with respect to the independent variable time on a long paper kept in the form of a roll. The independent variable time (t) then corresponds to the strip-length axis and the physical variables measured (y) are related to the chart width. Tracings are obtained by a writing process at sites on the chart short axis (y) corresponding to the physical variables magnitudes with the strip being moved at constant velocity to generate the time axis. Graphs cannot be interpreted if essential information is absent; scales and reference levels for each physical variable recorded and for time are all necessities. Additional information concerning the experimental conditions of the recording is also necessary and is preferably printed by the apparatus (data, investigated item, type of experiment, etc.). [Figure 15.1](#) shows different components of a

strip chart recorder. A typical industrial strip chart recorder is shown in [Figure 15.2](#)

Strip chart recorders consist of a roll or strip of paper that is passed linearly beneath one or more pens. As the signal changes, the pens deflect producing the resultant chart. Strip chart recorders are well suited for recording of continuous processes.

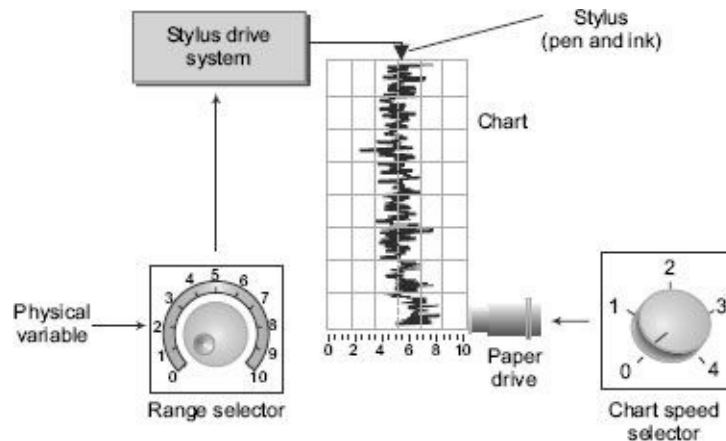

Figure 15.1 Strip chart recorder



Figure 15.2 Industrial strip chart recorder [Manf: Omega Corporation]

A strip chart consists of the following:

- (a) **Chart/Paper** Long graph paper kept on two rollers, lower roller drags the paper vertically with the help of a motor.
- (b) **Chart Speed Selector** Controls the speed of the roller at some specified speed selected by the operator and hence controls the time scale.
- (c) **Range Selector** Amplifier or attenuator which is to be adjusted according to the amplitude level of physical variable. If the physical variable to be recorded is of very low amplitude then it needs to be amplified with proper gain. The gain value is adjusted by selecting proper range.
- (d) **Stylus Driving System** Moves the stylus in proportion to the physical variable to be recorded, in most recorders, a synchronous motor is used for driving the paper.
- (e) **Stylus** Create marking/impression on the moving graph paper [most recorders use a pointer attached to the stylus, which (pointer) moves over a calibrated scale thus showing instantaneous value of the quantity being measured].

The most commonly used mechanisms employed for making marks on the papers are

- (i) **Pen and ink:** Marking with ink-filled stylus
- (ii) **Thermal type:** Marking with heated stylus on temperature sensitive paper (e.g. fax paper)
- (iii) **Impact type:** Marking with pressure sensitive paper (e.g. carbon paper)
- (iv) **Electrostatic stylus:** Marking with charged stylus on plain paper
- (v) **Optical type:** Marking with light ray on photosensitive paper

Strip chart recorders are commonly used in laboratory as well as process measurement applications. Modern strip chart recorders have the facility of

- (i) **Simultaneous recording and display of multipoint data**
- (ii) **Universal input:** The recorders accept wide range of dc voltage, all common thermocouple and RTD. Often these ranges can be programmed for each channel.
- (iii) **Universal power voltage** of 100 V ac to 240 V ac, 50/60 Hz
- (iv) **Alarm Display/Printings**
- (v) **Chart illumination** convenient to confirm printed signal in the night or in dark places.

There are various kinds of strip chart recorders. According to their working principles, these are divided in mainly two categories. One works on the principle of the galvanometer and other is called null type.

(a) Galvanometric Type Galvanometric instruments usually use a d'Arsonval galvanometer as the basic movement. This galvanometer consists of a moving coil (shown in [Figure 15.3](#)) suspended either on pivots or a taut ligament. The coil is then able to rotate in the field produced by a permanent magnet. When a small current is applied to the coil, a field is created which reacts with that of the permanent magnet, and the coil rotates. A control spring in a pivoted instrument and the ligament with a taut suspension provide an opposing torque. Thus, depending on the current applied, equilibrium will be established. A pointer shows the deflection. In practice, this principle is applied in several ways. In direct-writing moving-coil instruments, an arm with a pen attached, which is fed from an ink reservoir, is directly connected to the moving coil. The pen then writes in sympathy with the coil movement on a chart, which may be either in strip form or circular form. Such instruments are capable of recording full-scale deflections from upwards of 100 mV dc and 500 mV ac. Corresponding currents are 500 mA dc and 1 mA ac. Direct-writing instruments can be fitted with a variety of chart-drive mechanisms ranging from an alternating-current synchronous motor, with or without spring wound reserve (which enables the recorder to continue to operate for a reasonable period), to a completely

mechanically driven clock mechanism. This latter feature, of course, makes the instruments portable and for suitable for field use. There are many possible variations. Some manufacturers offer up to as many as six movements writing independently on one chart. With the use of shunts and current and voltage transformers, ranges may be extended for higher values. On some types, control facilities for high and low alarms are also fitted.

(b) Potentiometric Type With the development of ac amplifier techniques in the mid 1930s, the requirement for increased sensitivity in process control could be satisfied by the use of a closed-loop recorder. In addition, the mechanism, though more complicated, could be made much less susceptible to vibration. The self-balancing potentiometer type of instrument consists of a bridge circuit. Across one arm of the bridge is a reference voltage, and across the other arm is a feedback network (shown in Figure 15.4). Initially, the bridge is adjusted so that the servo amplifier and its motor are in balance and stationary. When a signal is fed to the amplifier, the output causes the servomotor to drive a balancing potentiometer, which in turn refers a feedback voltage to the amplifier input. When the two signals are equal and opposite, the system balances and the servomotor stops. If a pen unit is attached to the motor/ potentiometer mechanised drive, at the point of balance, the pen will show the proportional value of the input signal. As with galvanometric instruments, this principle may be applied in various ways.

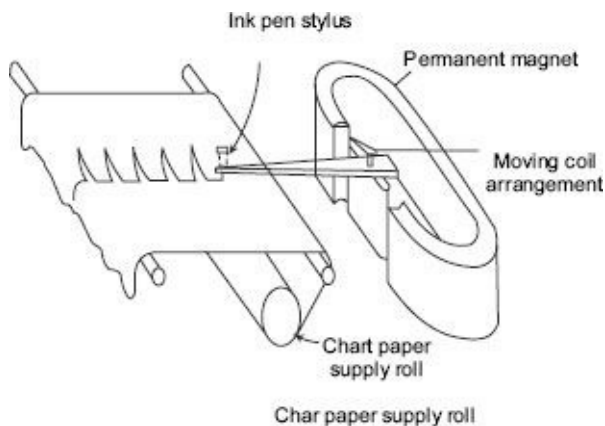

Figure 15.3 Galvanometer type recorder

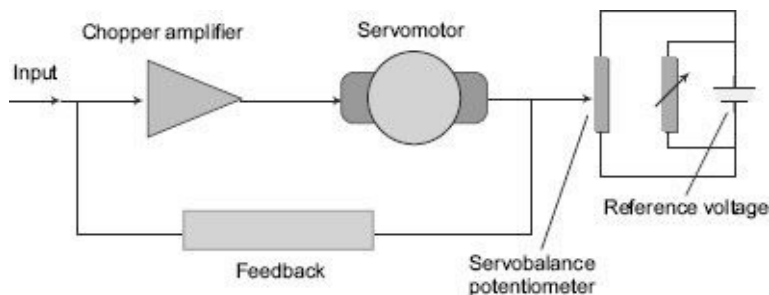

Figure 15.4 Potentiometric type recorder

This kind of recorders having very high input impedance, infinity at balance conditions, and a high sensitivity.

The most common application of potentiometric recorder is for recording and control of process temperatures. Self-balancing potentiometers are unduly used in industry because of the following reasons:

- (i)

Their action is automatic and thus eliminates the constant operation of an operator.

- (ii) They draw a curve of the quantity of being measured with the help of a recording mechanism.
- (iii) They can be mounted on the switchboard or panel and thus act as mounting devices for the quantity under measurement.

(c) Single-Point and Multi-point Recorders Instruments that record changes of only one measured variable are called single-point recorders.

A multi-point recorder may have as many as 24 inputs, with traces displaced in six colours.

2. Circular Chart Recorder

A circular chart recorder records data in a circular format. The paper is spun beneath one or more pens as shown in [Figure 15.5](#). The pens are deflected in proportion to the varying signal resulting in a circular chart. Circular chart recorders are ideal for batch processes where a set process time is known. The charts are normally designed to rotate in standard time periods, such as 1 hour, 24 hours, 7 days, etc., although many recorders are flexible enough to accommodate non-standard time periods.

These recorders were developed mainly to take advantage of the availability and convenience of a spring-wound clock and synchronous motor movements to drive the chart in a circular direction. The circular chart used here has concentric circles ruled on it to form its scales as shown in [Figure 15.5](#). In addition, there are printed arcs extending from the centre of the chart to the paper's edge. As the pen of the recorder is moved, it swings along these arcs; these arcs are called the 'time arcs'. The speed of the rotation of the chart is usually one revolution per 24 hours or per seven days or any other speed, which can be conveniently obtained by using a synchronous motor with suitable gear assembly. The radial position of the pen at any time indicates the instantaneous value of the quantity under measurement. A typical industrial circular recorder is shown in [Figure 15.6](#).

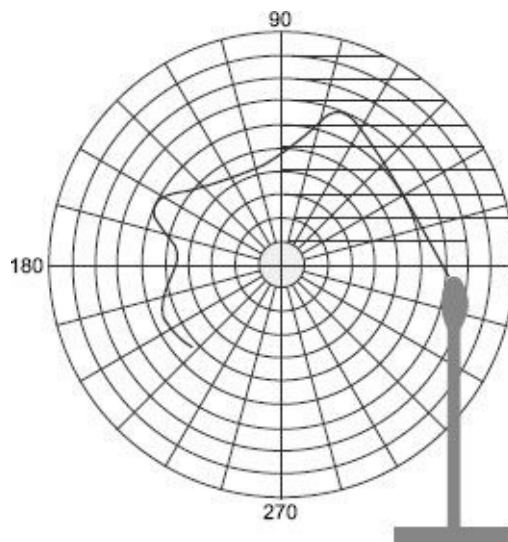

Figure 15.5 Circular chart recorder



Figure 15.6 Industrial circular chart recorder [Manf: Omega]

Chart diameter is limited to a maximum of 0.3 m. Speed of the chart is also limited, resolution along the scale length is usually non-uniform and the charts do not run for a long period. Magnitude of several variables can be recorded on a single chart which makes it easy and convenient to analyse the interrelationship of various measurements and also saves the panel mounting space.

The various drives for circular charts are classified as follows:

- (a) Mechanical (spring clock drive)
- (b) Pneumatic (air lock drive)
- (c) Electric (synchronous regulated dc motor or motor wound spring)
- (d) Dual powered drive (duplex), i.e. a synchronous motor and spring clock mechanical drive
- (e) Externally controlled drives

Circular chart recorders are particularly suitable for direct actuation by a number of mechanical sensors such as bellows, bourdon tubes, etc.

3. X-Y Recorder

With the development of the potentiometric principle, users were aware that a record was often required as the resultant of two varying signals, and thus the X-Y plotter was introduced (Figure 15.7). Today, X-Y plotters are as flexible as conventional potentiometric instruments, except that they have two completely independent servo-systems to operate the X and Y channels. The two most popular sizes are A4 and A3 (297 mm × 210 mm, 420 mm × 297 mm, respectively). Sensitivities similar to those obtainable with Y-t instruments are achieved, and, often, the more comprehensive instruments are also fitted with a time axis t , which provides single or repetitive time sweeps against the Y axis.

XY recorders accept two inputs and create a chart or graph of one input versus the other. They are commonly used to determine the relationship between the two inputs. For example, in a chemical process, an XY recorder might be used to monitor the effect temperature has on the pressure of the process. A typical industrial XY recorder is shown

in [Figure 15.7](#).

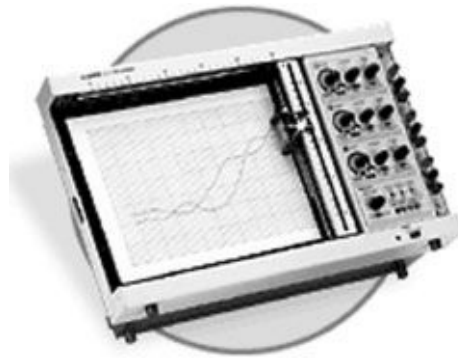

Figure 15.7 Industrial XY recorder [Manf: Omega]

This system has a pen which can be positioned along the two axes with the writing paper remaining stationary. There are two amplifier units, one amplifier actuates the pen in the Y-direction as the input signal is applied, while the second amplifier actuates the pen in the X-direction. The movements of the pen in X-and Y-directions are automatically controlled by means of a motor, pulleys and a linear potentiometer. Obviously, trace of the marking pen will be due to the combined effects of two signals applied simultaneously. In these recorders, an emf is plotted as a function of another emf There are many variations of X-Y recorders. With the help of these recorders and appropriate transducers, a physical quantity may be plotted against another physical quantity. [Figure 15.8](#) shows a block diagram of a typical analog X-Y recorder.

A signal enters in each of the two channels.

The signals are attenuated to the inherent full-scale range of the recorder (often 0.5 mA). The signal then passes to a balance circuit where it is compared with an internal reference voltage.

The error signal (i.e. the difference between the input signal voltage and the reference voltage) is fed to a “chopper” which converts dc signal to an ac signal.

The signal is then amplified in order to actuate a servomotor which is used to balance the system and hold it in balance as the value of the quantity being recorded changes.

The action described above takes place in both the axes simultaneously. Thus, we get a record of one variable with respect of another.

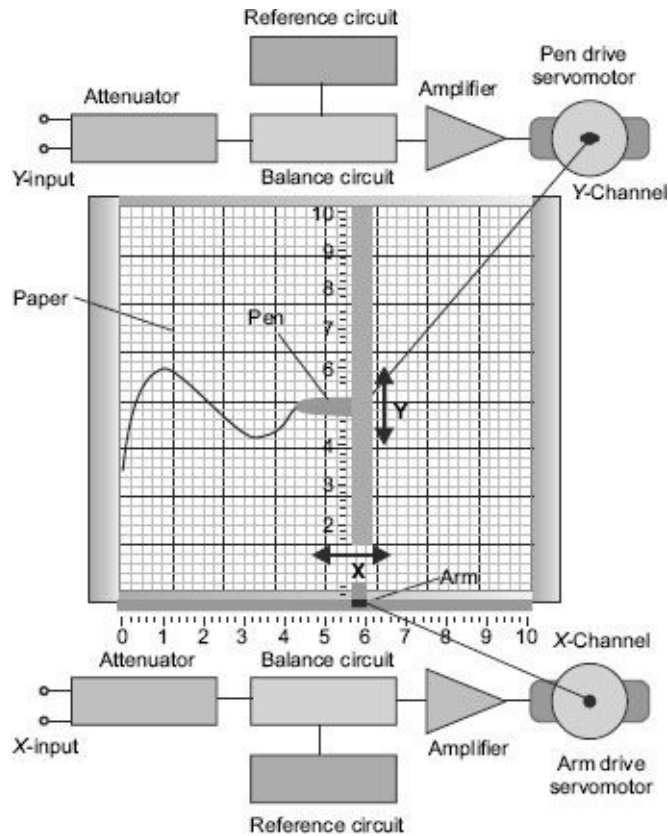

Figure 15.8 Different components of an XY recorder

Advantages

1. The instantaneous relationship between two physical quantities can be recorded.
2. The relationship between either electrical or non-electrical quantities can be recorded.
3. In modern types of recorders, zero offset adjustments are available.

Applications A few examples in which use of X-Y recorders are used are as under:

1. Plotting of stress-strain curves, hysteresis curves and vibrations amplitude against swept frequency
2. Pressure-volume diagrams for LC engines
3. Pressure-flow studies for lungs
4. Lift drag wind tunnel tests
5. Electrical characteristics of materials such as resistance versus temperature
6. Plotting the output from electronic calculators and computers
7. Speed-torque characteristics of motor
8. Regulation curves of power supplies
9. Plotting of characteristics of vacuum tubes, zener diodes, rectifiers and transistors, etc.

4. Hybrid Recorders

Hybrid chart recorders represent the latest generation of chart recorder and basically consist of a potentiometric chart recorder with an added microprocessor. The microprocessor provides for selection of range and chart speed, and also allows specification of alarm modes and levels to detect when measured variables go outside acceptable limits. Additional information can also be printed on charts, such as names, times and dates of variables recorded. Microprocessor-based, hybrid versions of circular

chart recorders also now exist. A typical industrial hybrid recorder is shown in [Figure 15.9](#).

A hybrid recorder can function as a recorder or data logger. Like a standard recorder, the hybrid recorder can generate a chart of the inputs. However, it can also produce a digital stamp of the data similar to a data logger. They are commonly available in multichannel designs although one print head normally handles all channels. This makes the hybrid recorder a cost-effective solution for multichannel systems although the response time is not as fast as recorders which have a unique pen for each channel.

5. Paperless Recorders

Paperless recorders are one of the latest types of recorders to emerge on the market. Paperless recorders display the chart on the recorders' graphic display rather than print the chart on paper. The data can normally be recorded in internal memory or to a memory card for later transfer to a computer. The major benefit of paperless recorders is conservation of paper and easy transfer to a computer. A typical industrial paperless recorder is shown in [Figure 15.10](#).



Figure 15.9 Industrial hybrid recorder [Manf: Omega]



Figure 15.10 Industrial paperless recorder [Manf: Omega]

6. Ultraviolet Recorders

The limited bandwidth problem of galvanometric recorders are due to system moment of inertia and spring constants can be reduced limited to the maximum bandwidth to about 100 Hz. Ultraviolet recorders work on very similar principles to standard galvanometric chart recorders, but achieve a very significant reduction in system inertia and spring constants by mounting a narrow mirror rather than a pen system on the moving coil. This

mirror reflects a beam of ultraviolet light onto ultraviolet sensitive paper. It is usual to find several of these mirror-galvanometer systems mounted in parallel within one instrument to provide a multi-channel recording capability, as illustrated in [Figure 15.11](#). This arrangement enables signals at frequencies up to 13 kHz to be recorded with a typical inaccuracy of $\pm 2\%$ full scale, while it is possible to obtain satisfactory permanent signal recordings by this method. Special precautions are necessary to protect the ultraviolet-sensitive paper from light before use and to spray a fixing lacquer on it after recording. Such instruments must also be handled with extreme care, because the mirror galvanometers and their delicate mounting systems are easily damaged by relatively small shocks. In addition, ultraviolet recorders are significantly more expensive than standard chart recorders.

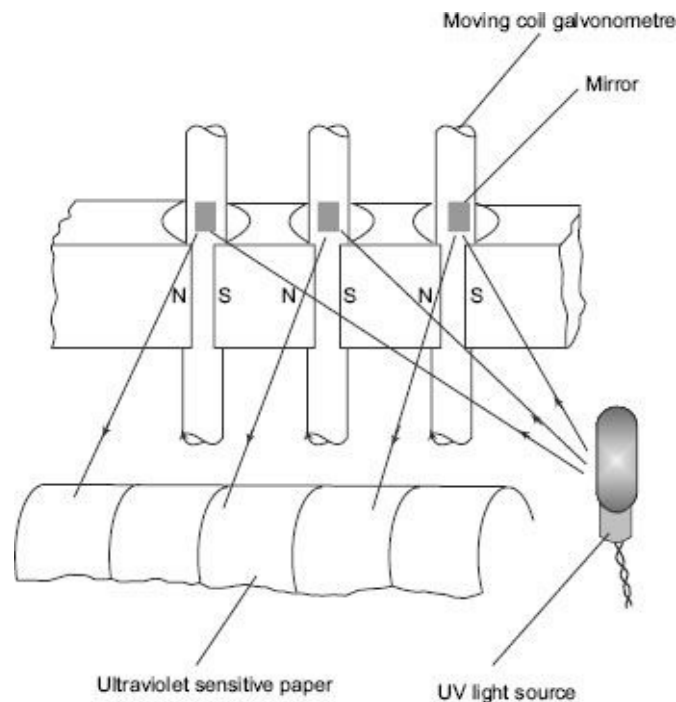

Figure 15.11 *Internal recording components of UV recorder*

7. Thermal Dot Array Recorders

Thermal dot array recorders have the advantage of not having any moving parts. The writing mechanism is an array of equidistant writing points which covers the total width of the paper. For writing, medium thermo-sensitive papers are generally used. In this array the writing system consists of miniature electrically heated coils. Maximum writing frequency is determined by thermal properties of the coils which are in close contact with the chart paper and the electric activating pulse. Heating of the thermo-sensitive paper results in a black dot with good long-term stability. The heating pulse is controlled in relation to the chart velocity in order to obtain sufficient blackness at high velocities. Tracing blackness or line thickness is seldom used for curve identification; and alphanumeric annotation is mostly applied. Different types of grid patterns can be selected by the user. Moreover, alphanumeric information can be printed for indicating experimental conditions. Ordinate axis resolution is determined by the dot array: primarily, 8 dots/mm; exceptionally, 12 dots/mm (as in standard laser printers). Most of the dot array instruments are intended for high-signal-frequency applications: per channel sampling frequencies of 100, 200, and even 500 kHz are used in real time. These sampling frequencies largely exceed the writing frequencies; during the writing cycle, data are

stored in memory and for each channel within each writing interval, a dotted vertical line is printed between the minimal and the maximal value. For example, a sine wave with a frequency largely exceeding the writing frequency is represented as a black band with a width equal to the sine amplitude. In this way, the graphs indicate the presence of a phenomenon with a frequency content exceeding the writing frequency.

15.2.2 Magnetic Disk and Tape Type Recorder

At present, magnetic recording technology dominates the recording industry. It is used in the forms of hard disk, floppy disk, removable disk, and tape with either digital or analog mode. In its simplest form, it consists of a magnetic head and a magnetic medium, as shown in Figure 15.12. The head is made of a piece of magnetic material in a ring shape (core), with a small gap facing the medium and a coil away from the medium. The head records (writes) and reproduces (reads) information, while the medium stores the information. The recording process is based on the phenomenon that an electric current i generates a magnetic flux f as described by Ampere's law. The flux f leaks out of the head core at the gap, and magnetises the magnetic medium which moves from left to right with a velocity V under the head gap. Depending on the direction of the electric current i , the medium is magnetised with magnetisation M pointing either left or right. This pattern of magnetisation is retained in the memory of the medium even after the head moves away. Magnetic tapes are still popular in several areas such as

1. Medical research
2. Patient monitoring
3. Surveillance
4. Spying
5. Production control

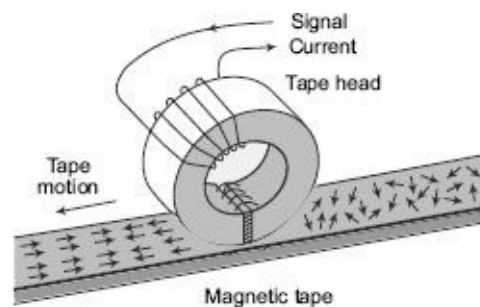

Figure 15.12 Magnetic tape recording

1. The Magnetic Tape

Before actually going into the details of the magnetic tape recorder, it is better to know about the tape which is used for this purpose. Actually, the tape is made out of a special type of plastic material which is stable and can withstand continuous rubbing against the head. Normally, this material is either PVC or Mylar which are quite resistant to wear and stretching is necessary for the tape to remain useful for a long period of time. On top of this plastic base, there is a thin layer of magnetic material, usually iron oxide. The particles of this magnetic material are shaped in the form of tiny needles and occupy the top portion of the plastic base. The typical thickness of the tape is of the order of 25 micrometres.

During recording, an electrical signal causes current to flow through the coil producing

a magnetic field in the gap, as shown by the blue lines of force in [Figure 15.12](#). As the electrical signal varies in amplitude and frequency, so does the magnetic field. The tape consists of a plastic film coated with a material that is magnetised by the field as it passes over the gap. As the magnetic field varies in strength, so does the magnetism stored on the tape. During playback, the tape passes over the same head (it is called the record/playback head). This time the magnetism stored on the tape induces a voltage in the head coil. This voltage is amplified and used for retrieval of the recorded signal.

(a) Principle behind Magnetic Recording—Hysteresis Loop Those of you who have studied physics must surely remember that there are two magnet types, namely permanent magnet and temporary magnet. In a temporary magnet, the magnetism is induced as a result of some force which aligns the magnetic particles along a specific axis. This force could be due to rubbing of another magnetic material or an electromagnetic field applied using a varying current.

Take a look at the typical magnetisation curve in [Figure 15.13](#), which shows the graph of the magnetising force H against the flux density B . When a material is in purely non-magnetised state and a magnetising force is applied, the flux density rises along the dotted line OAC . But now if the current is brought to zero, the flux does not reduce to zero but a residual flux remains and the current has to be extended into the negative region (opposite direction) to bring B to zero again.

Hence, a loop is formed of the overall process as can be seen from the diagram and this is known as the *magnetisation curve* for the material or is also known as the *hysteresis loop*. Now this property may be undesirable in several situations but here you can intuitively imagine a great use for the same. Once the signal is applied to the magnetic tape via the recording head, the section of the tape gets magnetised in accordance with the signal which leaves a residual flux on the tape. This acts to store that signal on the tape which can be played back using the playback head.

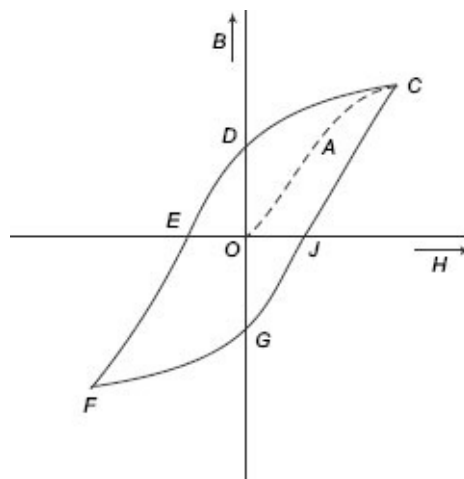

Figure 15.13 *Hysteresis loop*

(b) The Basic Arrangement The basic circuit of a magnetic recording and playback system is quite simple and can be understood by seeing [Figure 15.14](#), which shows the entire arrangement. Of course, this is a highly simplified sketch without the inside nuts and bolts, yet it is useful to take a broad view of the system.

As you can see, the entire system consists of two portions—a mechanical arrangement

to make the magnetic tape move across two points, and an electrical system which does the real job. The mechanical movement is achieved with the help of motor drive and a combination of rollers and belts. The electrical part is taken care of by appropriate circuits which do the work of recording, playback and amplification of sound. There are two heads which are used for recording and playback of the signals respectively.

(c) **Recording and Playback** The basic principle of operation is quite simple. As the tape rubs against the recording head, it applies a magnetic field which is proportional to the input signal. This signal orients the magnetic particles in a specific format which acts as indicators to the pattern of signal stored. When the playback head rubs against the tape, the signal is reproduced since now the particles induce similar magnetic patterns in the head. If you want to read more technical details about this process you can refer to the next article on this topic (coming soon and will be linked here).

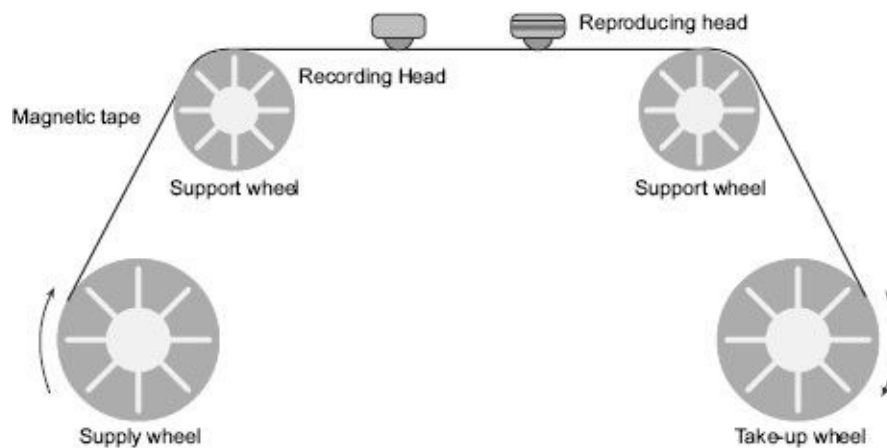

Figure 15.14 *Magnetic tape recording mechanism*

There are several types of recording techniques which are used for recording on magnetic tapes and these can be

- Direct recording
- Frequency modulation recording
- Pulse duration modulation recording
- Digital recording

We will take a look at all these methods of recording on magnetic tapes

2. Direct Recording

If the signals are recorded in an analog manner in a way so that the amplitude and frequency of the signal is recorded linearly as a variation of the amplitude, magnetisation and wavelength on the magnetic tape, such a system of recording is known as direct recording. Since low distortion is required on the playback signal, this is achieved by adding a high-frequency ac bias signal to the signal being recorded.

This method of recording is most suited for audio signals rather than any other purpose. This is so because the human ear has an in-built mechanism which averages the amplitude variation errors.

3. FM Recording

We have learnt about frequency modulation in a previous article and know that frequency modulation is all about using a sine wave carrier signal and modulating or modifying it as

per the signal to be loaded on that carrier signal. Similarly, in case of FM recording in magnetic tapes, a frequency modulator is used to feed the input signal onto the carrier signal. This signal is then recorded onto the magnetic tape either with or without the ac bias signal as described in the previous section of direct recording.

Figure 15.15 shows a simplified view of such a recording system without showing the internal details. As you can see, when the signal is now reproduced using the playback head, it needs to be passed through a demodulator which separates the sine carrier wave from the recorded signal and then reproduced.

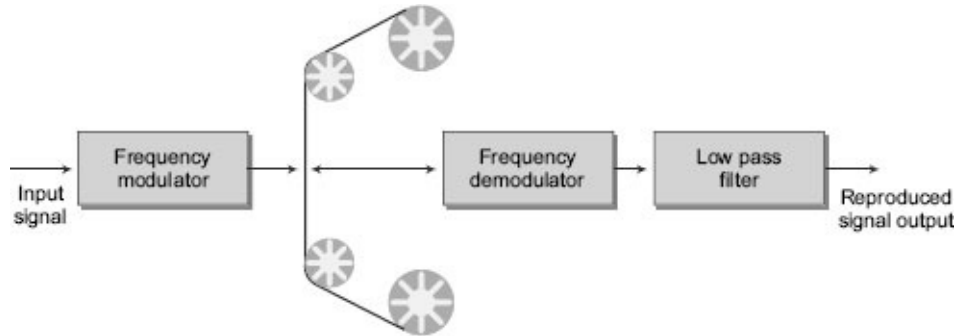

Figure 15.15 FM recording mechanism

This system is more complicated in its construction and expensive to build because of the various extra circuitries involved in it. Hence, normally it is only used in situations where amplitude-variation errors are not acceptable, such as instrumentation where the parameters of some delicate industrial process are recorded. Despite this advantage, this system has a poor high-frequency response and requires a higher tape speed which needs to be precisely controlled.

4. PDM Recording

In this type of magnetic tape-recording system, the input signal is converted into a pulse signal. The duration of the pulse is in tune with the amplitude of the signal; hence the name *pulse duration modulation* since the duration of the pulse varies with the input signal.

Obviously, since the continuous input signal is divided into discrete pulses, this type of recording system is even more complicated and expensive than the FDM system described previously. Yet it is used in situations which require special quality recording such as situations where a large number of variables are monitored and they change very slowly. The advantages of such a system are

- (a) Multi channel recording
- (b) Great degree of accuracy
- (c) Very low signal/noise ratio

5. Benefits of Magnetic Recording

Now we will take a look at some of the advantages and drawbacks of the magnetic tape systems.

- (a) The frequency range of the signals stored on the tape has a very wide range and spectrum, and an equally good dynamic range.

- (b) here is very less distortion of signals stored on the tape. This is specifically useful for audio/ video purposes
- (c) Tapes can be used to store multiple signals along the same length, thus increasing efficiency.
- (d) Even though you might think that electronic memories are getting cheaper, the tape still is a winner in terms of cost per bit of storage. This is mainly due to large surface area of the tape and very high data density.
- (e) Time base of the stored signal data can be varied as per requirement. This means that signals recorded at fast speed can be played back at slower speed and vice versa, which is useful in several applications

15.2.3 Oscillographic Recorders

Although, strictly speaking, oscillographs are direct-writing instruments, they also employ a moving coil, but the writing element uses much more power and is fed from an ac amplifier feeding a driver power amplifier. The writing element, usually referred to as a “pen motor”, can consume more than 100 W. The angular deflection of the motor is often restricted to as little as 17° with the result that response times of up to 150 Hz can be obtained. Oscillographs are suitable for recording high transient signals such as occurring in strain-gauge measurements and in medical applications such as measuring heartbeat and brain-response (ECGs and EEGs). The recording is usually made on inkless paper using a heated stylus.

Used primarily for applications in the test and research fields, the capabilities of oscillographic recorders and the newer digital oscilloscopes have expanded greatly over the past several years. An oscillograph is a device for determining waveforms by plotting instantaneous values of a quantity such as voltage as a function of time. A decade ago, this implied either a recording galvanometer or a CRT recorder— analog instruments that afforded the needed bandwidths in excess of 20 kHz.

As in other recorder developments, however, digital is the buzzword today and Digital Storage Oscilloscopes (DSOs) or simply digital oscilloscopes have proliferated. These may be defined as oscilloscopes that digitise an input signal for storage in memory for later display or analysis. It is a logical and relatively simple step to use the stored data to provide a chart record, and many DSOs do just that, essentially acting as data loggers.

A recent survey lists some 30 different suppliers of DSOs, many of them PC-based. They cover a range of bandwidths—some around 40 to 50 MHz while others go as high as 350 MHz. These are sophisticated electronic instruments that have capabilities far beyond traditional analog CRT-based oscilloscopes, which have been around for many decades.

15.3

DIGITAL RECORDERS

Digital recorder record the data in the form of ‘1’ and ‘0’. There are several types of digital recorders. The following section discusses data loggers and magnetic-type digital recorders.

15.3.1 Data Logger

Data loggers are stand-alone devices that can record information electronically from internal or external sensors or other equipment that provide digital or serial outputs.

1. Key Features of Data Loggers

(a) **Stand-alone Operation** Most data loggers are normally configured with a PC, some models can be configured from the front panel provided by the manufacturer. Once the data loggers are configured, they don't need the PC to operate.

(b) **Support for Multiple Sensor Types** Data loggers often have universal input type which can accept input from common sensors like thermocouple, RTD, humidity, voltage, etc.

(c) **Local Data Storage** All data loggers have local data storage or internal memory unit, so all the measured data is stored within the logger for later transfer to a PC.

(d) **Automatic Data Collection** Data loggers are designed to collect data at regular intervals, 24 hours a day and 365 days a year if necessary, and the collection mode is often configurable.

Data logging and recording are both analog terms in the field of measurement. Data logging is basically measuring and recording of any physical phenomena or electrical parameter over a period of time. The physical phenomena can be temperature, strain, displacement, flow, pressure, voltage, current, resistance, power, and many other parameters. Typical industrial data loggers are shown in [Figure 15.16](#).



Figure 15.16 Typical data loggers [Manf: National Instrument and Omega Corp.]

The data logger collects information about the state of any physical system from the sensors. Then the data logger converts this signal into a digital form with the help of an A/D converter. This digital signal is then stored in some electronic storage unit, which can be easily transferred to the computer for further the analysis, the schematic diagram of a data-logging application in industrial environment is shown in [Figure 15.17](#).

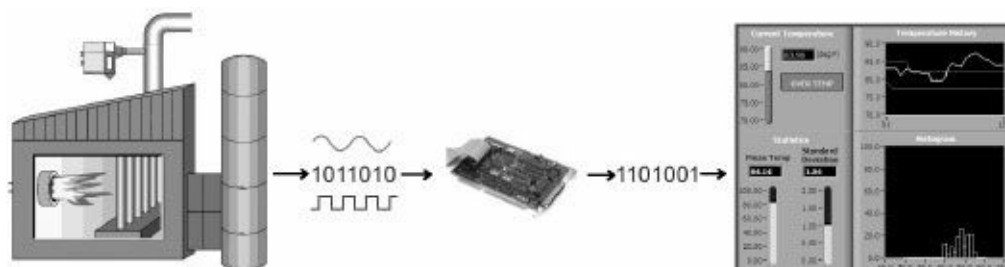

Figure 15.17 Industrial data logging and display

A few basic components that every data logger must have are shown in [Figure 15.17](#), which are:

1. Hardware components like sensors, signal conditioning, and analog-to-digital converter, etc.
2. Long-term data storage, typically onboard memory or a PC
3. Software for collecting data, analysing and viewing

2. Functions of Data Loggers

Beyond the acquiring and storing data, a data logger often performs various kinds of other jobs like offline and online analysis, display, sharing data with other devices connected with the network, reporting events and providing alarm whenever some critical situation arises. A complete data-logging application typically requires most of the elements shown in [Figure 15.18](#).

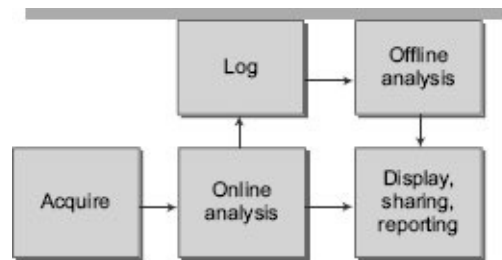

Figure 15.18 Different components of data loggers

15.3.2 Digital Tape Recording

The very mention of the name *digital tape recording* brings the picture of hard drives, flash memories, etc. to our mind, but this also refers to another method of recording on the good old magnetic tape as well. [Figure 15.19](#) shows the digital tape recording mechanism.

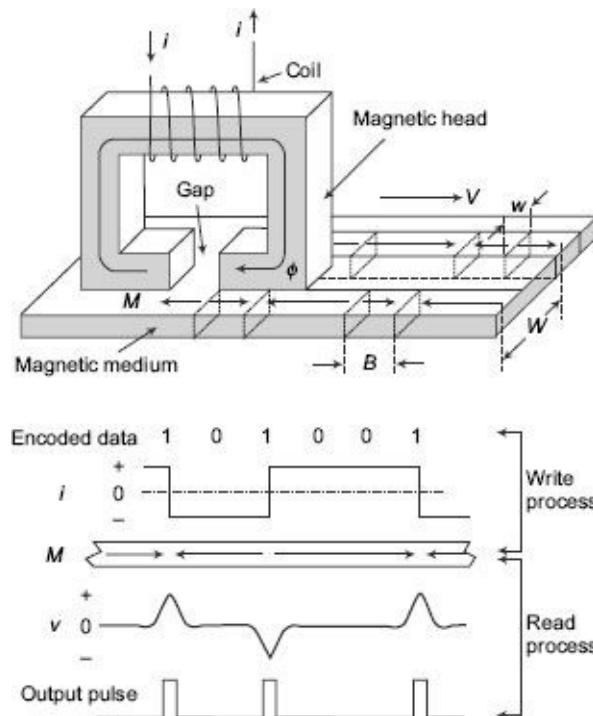

Figure 15.19 Digital tape recording mechanism

The only difference is that the signals are recorded in the form of 0s and 1s which are typical of the digital world. Obviously, it would require modulation of some form or the

other, to convert analog to digital signals and hence there are several methods of magnetic tape recording which fall under the category of digital recording.

Some of these methods are

1. Return-to-bias method
2. Return-to-zero method
3. Non-Return-to-zero method

The detailed description of these methods would be a bit too complicated here so we will just go through the basics of one of these, let us say the Return-to-Bias (RB) method. Figure (15.19) schematically shows the digital recording/reproducing process. First, all user data are encoded into a binary format—a serial of 1s and 0s. Then a write current i is sent to the coil. This current changes its direction whenever a 1 is being written. Correspondingly, a change of magnetisation, termed a *transition*, is recorded in the medium for each 1 in the encoded data. During the reproducing process, the electric voltage induced in the head coil reaches a peak whenever there is a transition in the medium. A pulse detector generates a pulse for each transition. These pulses are decoded to yield the user data. The minimum distance between two transitions in the medium is the flux change length B , and the distance between two adjacent signal tracks is the track pitch W , which is wider than the signal track width w . The flux change length can be directly converted into bit length with the proper code information. The reciprocal of the bit length is called *linear density*, and the reciprocal of the track pitch is termed *track density*. The information storage area density in the medium is the product of the linear density and the track density. This area density roughly determines how much information a user can store in a unit surface area of storage medium, and is a figure of merit for a recording technique. Much effort has been expended to increase the areal density. For example, it has been increased 50 times during 90's.

15.4

DISPLAY SYSTEM

The display system acts as a final link between the measuring process and the user. If the display is not easy to see and easy to understand then that process is compromised. The user's sensory capabilities and cognitive characteristics, therefore, must both be addressed in display-system selection. Furthermore, display technologies and performance capabilities are easier to evaluate in the context of their intended application. The following section discusses various kind of commonly used display system.

15.4.1 Cathode Ray Tube (CRT)

The Cathode Ray Tube (CRT) was developed for television in the 40s. Now it has wide range of applications in oscilloscopes, radar and monitors, etc.

It consists of a glass envelope made from a neck and cone. All air has been extracted so that it contains a vacuum. At the narrow end are pins which make connection with an internal electron gun, as shown in [Figure 15.20](#). Voltages are applied to this gun to produce a beam of electrons. This electron beam is projected towards the inside face of the

screen.

Different basic component of CRTs are electron gun, electron accelerating anode, horizontal and vertical electric field coils, electron beam and a screen coated with phosphor. The electron gun generates a narrow beam of electrons. The anodes accelerate the electrons. Deflecting coils produce an extremely low-frequency electric field that allows for constant adjustment of the direction of the electron beam. There are two sets of deflecting coils: horizontal and vertical. (In the figure, only one set of coils is shown for simplicity). The intensity of the beam can be varied. The electron beam produces a tiny, bright visible spot when it strikes the phosphor-coated screen. The screen is covered with a fine layer of phosphorescent elements, called *phosphors*, which emit light by excitation when electrons strike them, creating a lit-up dot called a *pixel*.

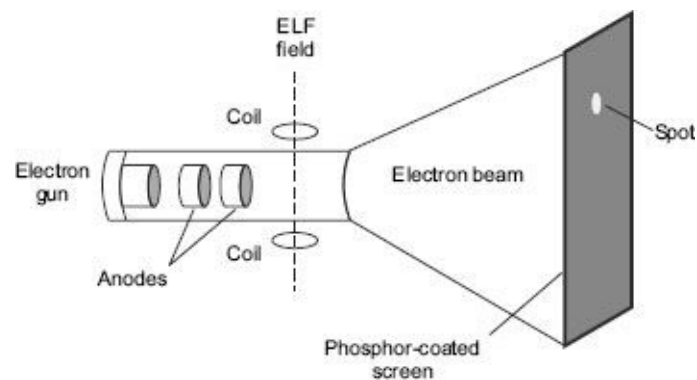

Figure 15.20 Internal components of a CRT

To produce an image on the screen, complex signals are applied to the deflecting coils, and also to the apparatus that controls the intensity of the electron beam. This causes the spot to race across the screen from right to left, and from top to bottom, in a sequence of horizontal lines called the *raster*. As viewed from the front of the CRT, the spot moves in a pattern similar to the way your eyes move when you read a single-column page of text. But the scanning takes place at such a rapid rate that your eye sees a constant image over the entire screen.

The illustration shows only one electron gun. This is typical of a monochrome, or single-colour CRTs. However, virtually all CRTs today render colour images. These devices have three electron guns, one for the primary colour red, one for the primary colour green, and one for the primary colour blue. The CRT thus produces three overlapping images: one in red (R), one in green (G), and one in blue (B). This is the so-called *RGB colour model*.

In computer systems, there are several display modes, or sets of specifications according to which the CRT operates. The most common specification for CRT displays is known as SVGA (Super Video Graphics Array). Notebook computers typically use liquid crystal display. The technology for these displays is much different than that for CRTs.

Cold Cathode Display

A cathode is any electrode that emits electrons as discussed in the section on CRT display. Generally, the cathode is heated so that electron emission occur at lower potential difference these cathode are called hot cathode and are widely used in vacuum tube CRT monitor oscilloscope, etc. By taking advantage of thermionic emission, electrons can

overcome the work function of the cathode with lower electric field. But in the case of cold cathode, sufficient voltage is provided so that electrons can overcome the work function and come out from the cathode at ambient temperature. Because it is not deliberately heated, such a cathode is referred to as a cold cathode. Although several mechanisms may eventually cause the cathode to become quite hot once it is operating. Most cold cathode devices are filled with a gas which can be ionised. A few cold cathode devices contain a vacuum.

15.4.2 Light Emitting Diode (LED)

One of the cheapest and convenient ways to display information electronically is by using Light-Emitting Diodes (LEDs). It is basically a *p-n* junction photodiode when excited at forward-bias condition emits light (basic theory of LEDs are discussed in chapter on “Fibre Optic Measurements”). It can be easily interfaced with a simple electronic circuit and is durable and reliable. These LEDs are often arranged in different formats to display information. Among these, the seven segments configuration and dot matrix display are very common and widely used. The seven-segment configuration of an LED arranged in the form of the digit 8 can be restrictive in that it does not adequately allow the display of some alphanumeric characters. By contrast, the versatility of a dot-matrix arrangement allows an LED unit to display more complicated shapes. The following sections discuss the about seven-segment and dot-matrix LED display.

1. The Seven Segment Display

One common requirement for many different digital devices is a visual display. Individual LEDs can of course display the binary states, i.e. ‘ON’ or OFF’. But when some numbers or characters are to be displayed then some arrangement of the LEDs are required. One possibility is a matrix of LEDs in a 7×5 array. However, if only numbers are to be displayed then this becomes a bit expensive. A much better way is to arrange the minimum possible number of LEDs in such a way that it can represent a number requiring only 7 LEDs. A common technique is to use a shaped piece of translucent plastic to operate as a specialised optical fibre, to distribute the light from the LED evenly over a fixed bar shape. The seven bars are laid out as a squared-off figure “8”. The result is known as a seven-segment LED.

Seven-segment displays having a wide range of applications. They used in clocks, watches, digital instruments, digital balances and many household appliances already have such displays.

There are basically two type of seven-segment displays—common cathode and common anode. *The common-anode type* is shown in [Figure 15.21](#), where ‘a’, ‘b’, ‘c’, ‘d’, ‘e’, ‘f’ and ‘g’ represent individual LEDs which are arranged as shown in the figure. In order to display numbers often decimal point have to be displayed. For that, another LED has been added, which is represented by ‘dp’ (decimal point).

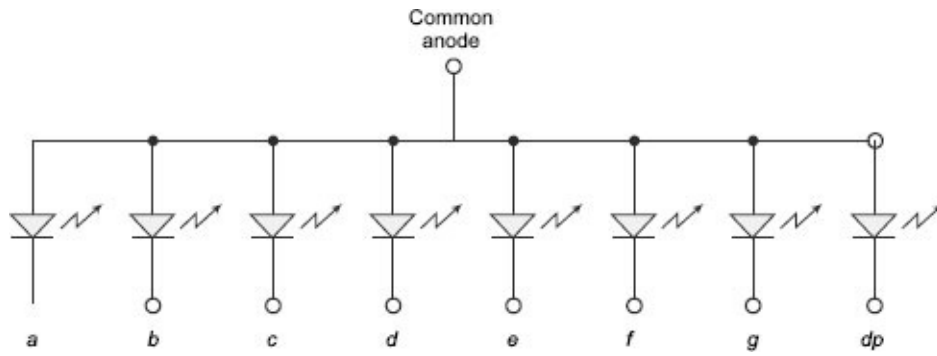

Figure 15.21 Common anode connection of seven segment display unit

A typical seven-segment display unit is shown in [Figure 15.22](#). [Figure 15.23](#) shows the pin diagram of a common anode type seven-segment display. That means that the positive leg of each LED is connected to a common point which is the Pin 3 in this case. Each LED has a negative leg that is connected to one of the pins of the device. To make it work, you need to connect the pin 3 to 5 volts. Then to make each segment light up, connect the ground pin for that LED to ground. A resistor is required to limit the current. Rather than using a resistor from each LED to ground, you can just use one resistor from V_{cc} to the pin 3 to limit the current.

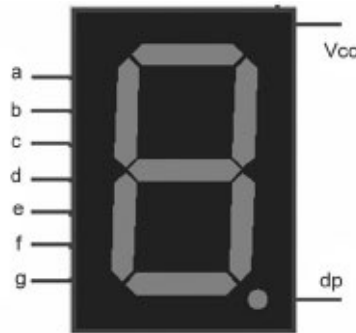

Figure 15.22 Typical seven segment display unit

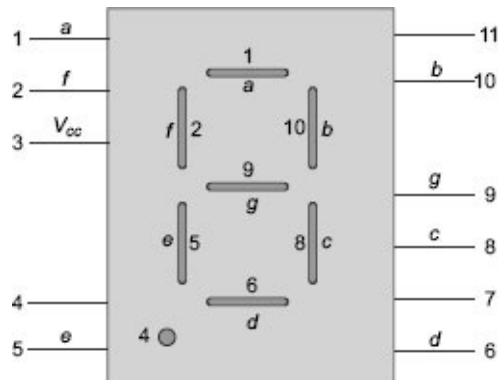

Figure 15.23 Pin diagram of seven segment display unit

Table 15.1 shows how to form the numbers 0 to 9 and the letters A, B, C, d, E, and F. '0' means that pin is connected to ground. '1' means that pin is connected to V_{cc} .

Table 15.1 Forming numbers and letters.

	<i>a (Pin 1)</i>	<i>b (Pin 10)</i>	<i>c (Pin 8)</i>	<i>d (Pin 6)</i>	<i>e (Pin 5)</i>	<i>f (Pin 2)</i>	<i>g (Pin 9)</i>
0	0	0	0	0	0	0	1
1	1	0	0	1	1	1	1
2	0	0	1	0	0	1	0
3	0	0	0	0	1	1	0
4	1	0	0	1	1	0	0
5	0	1	0	0	1	0	0
6	0	1	0	0	0	0	0
7	0	0	0	1	1	1	1
8	0	0	0	0	0	0	0
9	0	0	0	1	1	0	0
A	0	0	0	1	0	0	0
b	1	1	0	0	0	0	0
C	0	1	1	0	0	0	1
d	1	0	0	0	0	1	0
E	0	1	1	0	0	0	0
F	0	1	1	1	0	0	0

2. Dot Matrix Display

LEDs are arranged in matrix form—common configurations are 5×7 , 5×8 and 8×8 , as shown in [Figure 15.4](#). Based on the electrode connections, two kinds of LED matrices are possible, one is common anode. All the LEDs in a row having the anode are connected together. The other one is common cathode, having all LEDs in a row, the common cathode or cathodes are shorted. It is easier to understand the construction and interface capabilities of an LED matrix using an illustration. [Figure 15.24](#) depicts a matrix construction of the common-anode type. A single matrix is formed by thirty-five LEDs arranged in five columns and seven rows (5×7). The anodes of the five LEDs forming one row are connected together. Similarly, the cathodes of the seven LEDs of a column are connected together. In this arrangement of LEDs, the cathodes are switched to turn the LEDs of a row on or off.

The matrix (unit) illustrated in [Figure 15.25](#) can be used to display a single alphanumeric character. Several such units can be placed next to each other to form a larger panel to display a string of characters.

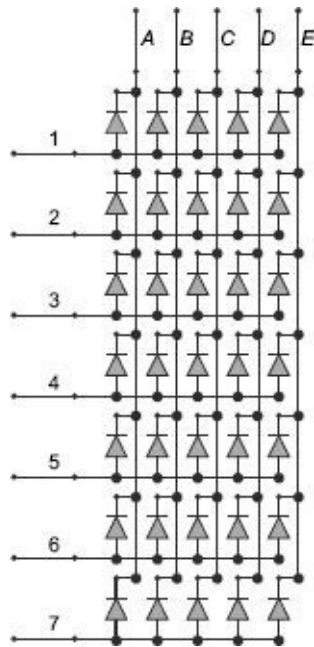

Figure 15.24 LED Matrix with common-anode arrangement

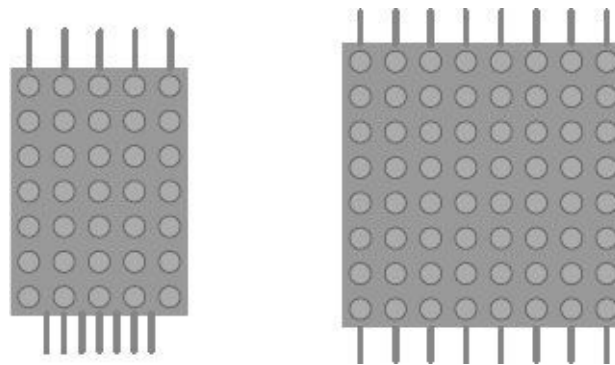

Figure 15.25 5×7 and 8×8 dot matrix display

3. Display of Information using LED Matrix

From Figure 15.26 it is clear that switching/multiplexing of rows is required to display a character on the matrix unit. These are often done by using external hardware like latches. Each row of the LED is driven for a brief period before switching to the next row. As the human eye retains a visual impression of an object for a short duration after the object is removed. Retention time depends on the brightness of the image. Due to this visual phenomenon termed persistence of vision, the human eye considers that the LEDs are glowing continuously and can visualise the characters.

Rapid switching between rows produces the illusion that all the rows are ON at the same time. To function as intended, two additional requirements must be met:

1. The LEDs must be overdriven proportionately or they can appear dim. The dimness occurs because a row is ON for only a fraction of time.
2. The rows must be updated often enough (e.g. each row is scanned about 30–40 times per second), to avoid display flicker. For actual character display, it is necessary to map the shape of the character to the 5x7 LED matrix. [Figure 15.26](#) illustrates the characters A and B.

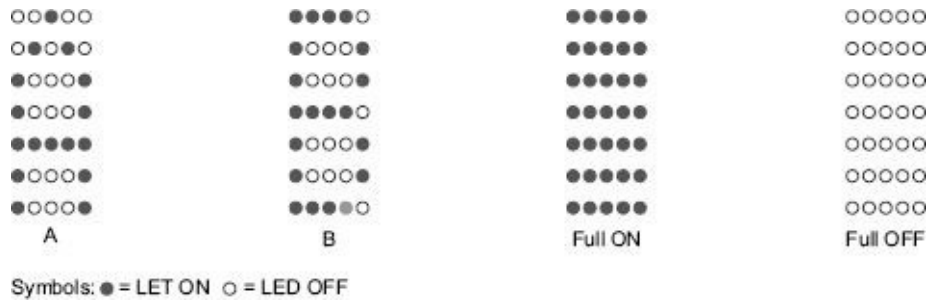

Figure 15.26 Illustration of the Characters A and B

For any given character, a corresponding pattern of LED ON and LED OFF must be generated, for example, the character A, as displayed in the figure, is formed with the pattern shown in Table 15.2.

Table 15.2 Display Pattern for the Character A

	C0	C1	C2	C3	C4	C0	C1	C2	C3	C4	Data
R0	OFF	OFF	ON	OFF	OFF	1	1	0	0	1	0 × 1B
R1	OFF	ON	OFF	ON	OFF	1	0	1	0	1	0 × 15
R2	ON	OFF	OFF	OFF	ON	0	1	1	1	0	0 × 0E
R3	ON	OFF	OFF	OFF	ON	0	1	1	1	0	0 × 0E
R4	ON	ON	ON	ON	ON	0	0	0	0	0	0 × 00
R5	ON	OFF	OFF	OFF	ON	0	1	1	1	0	0 × 0E
R6	ON	OFF	OFF	OFF	ON	0	1	1	1	0	0 × 0E

Note: 0 = LED ON; 1 = LED OFF .

Other characters/objects can be developed in a similar manner and stored in the memory to be used while displaying. By frequently switching the rows or columns with the proper selection of LED ON/ OFF patterns, the human eye perceives the display as continuous.

15.4.3 Liquid Crystal Display (LCD)

The Liquid Crystal Display (LCD) has been one of the enabling technologies of the current electronic revolution. It is an essential part of every mobile phone, every laptop and every personal organiser. *Liquid crystal* is an organic compound that polarises any light that passes through it. A liquid crystal also responds to an applied electric field by changing the alignment of its molecules, and in so doing changing the direction of the light polarisation that it introduces. Liquid crystals can be trapped between two parallel sheets of glass, with a matching pattern of transparent electrode on each sheet. Figure 15.27 shows different layers of a typical LCD display. When a voltage is applied to the electrodes, the optical character of the crystal changes and the electrode pattern appears in the crystal. A huge range of LCDs has been developed, including those based on seven-segment digits or dot matrix formats, as well as a variety of graphical forms. Many general-purpose displays are available commercially.

The liquid crystal fluid is the active medium that is used to create an image. It consists of a very large number of elongated crystals suspended in a fluid. This reservoir is sandwiched between two thin sheets of glass. Each piece of glass has a transparent conductive pattern bonded to it. The crystals are aligned in a spiral pattern until an electric field is impressed on the conductors.

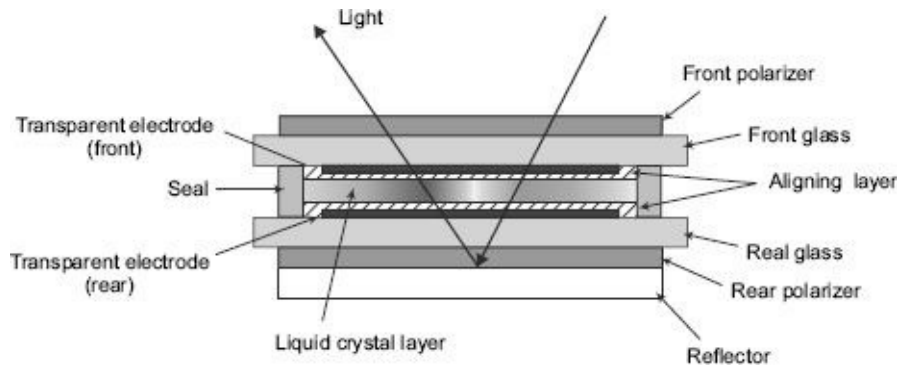

Figure 15.27 Different layers of a typical LCD display

A sheet of polarising material is bonded to the outside surfaces of both the front and rear glass covers. As incident light of random polarisation enters the top polarizer, it is stopped except for that which is polarised in the proper direction. With no electric field applied, the light is twisted or its polarisation is changed by the spiral pattern of the crystals. The bottom polariser is aligned opposite of the top one but the “twisted” light is now aligned with the bottom polariser and passes through. The display is now transparent and appears light.

A simple black-or-white LCD display works by either allowing daylight to be reflected back out at the viewer or preventing it from doing so—in which case the viewer sees a black area. The liquid crystal is the part of the system that either prevents light from passing through it or not.

The crystal is placed between two polarising filters that are at right angles to each other and together block light. When there is no electric current applied to the crystal, it twists light by 90° , which allows the light to pass through the second polariser and be reflected back. But when the voltage is applied, the crystal molecules align themselves, and light cannot pass through the polariser: the segment turns black, this phenomena is shown in [Figure 15.28](#).

Many other types of LCD displays are being developed for the laptop and CRT replacement market including full colour versions. These include double and Triple Twisted Nematic (DSTN and TSTN) displays and the Active-matrix Thin-film Twisted Nematic and Metal-Insulated-Metal Twisted Nematic (TFT-TN and MIM-TN) displays. Unfortunately, these advanced display are too expensive for most of the calculator market. TN LCDs almost completely dominate today’s calculator market due to their extremely low power requirements, thin size and low cost.

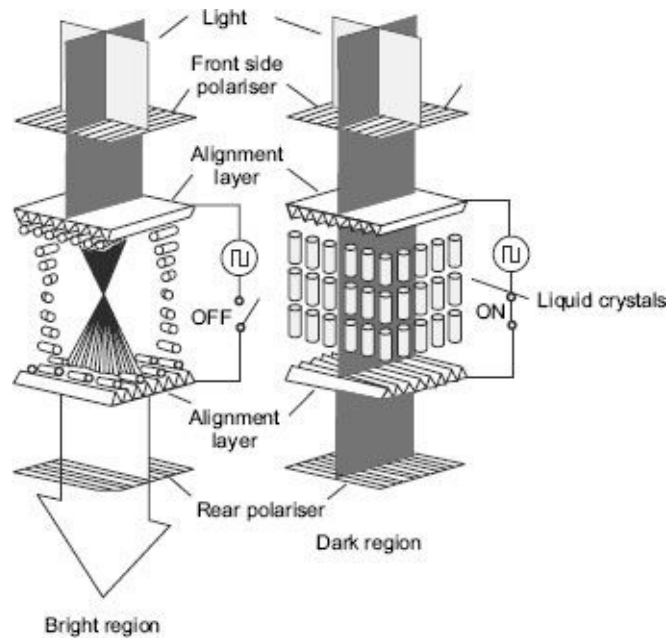

Figure 15.28 Working principle of LCD

Table 15.3 Comparison of CRT and LCD

Cathode Ray Tubes	Liquid Crystal Displays
<p>Advantages</p> <ul style="list-style-type: none"> • Fast response and high resolution possible • Full colour (large modulation depth of E-beam) • Saturated and natural colors • Inexpensive, matured technology • Wide angle, high contrast and brightness 	<p>Advantages</p> <ul style="list-style-type: none"> • Small in size • Light weight (typ. 1/5 of CRT) • Low power consumption (typ. 1/4 of CRT) • Completely flat screen—no geometrical errors • Crisp pictures—digital and uniform colours • No electromagnetic emission • Fully digital, signal processing possible • Large screens (>20 inch) on desktops
<p>Disadvantages</p> <ul style="list-style-type: none"> • Large and heavy (typ. 70 × 70 cm, 15 kg) • High power consumption (typ. 140W) • Harmful dc and ac electric and magnetic fields • Flickering at 50–80 Hz (no memory effect) • Geometrical errors at edges 	<p>Disadvantages</p> <ul style="list-style-type: none"> • High price (presently 3 × CRT) • Poor viewing angle (typ. +/- 50 degrees) • Low contrast and luminance (typ. 1:100) • Low luminance (typ. 200 cd/m²)

15.4.4 Flat Panel Display

Flat-screen monitors, often termed Flat Panel Displays (FPDs), are becoming more and more popular, as they take up less space and are less heavy than traditional CRT monitors. Other greater advantages of FPDs are they consume less energy when compared to CRT monitors, and also have less electromagnetic radiation. There are basically two types of Flat Panel Display (FPD)—the popular one is Liquid Crystal Display (LCD) and the other one is Plasma Display Panel (PDP).

The theory of Liquid Crystal Displays was discussed in the LCD section. Here, Plasma

Display Panel (PDP) will be discussed in brief.

Plasma Display Panel (PDP)

A Plasma Display Panel (PDP) is a type of flat panel display now commonly used for large TV displays (typically above 32 inches). It is often used in the home environment and is becoming increasingly popular in modern cultures.

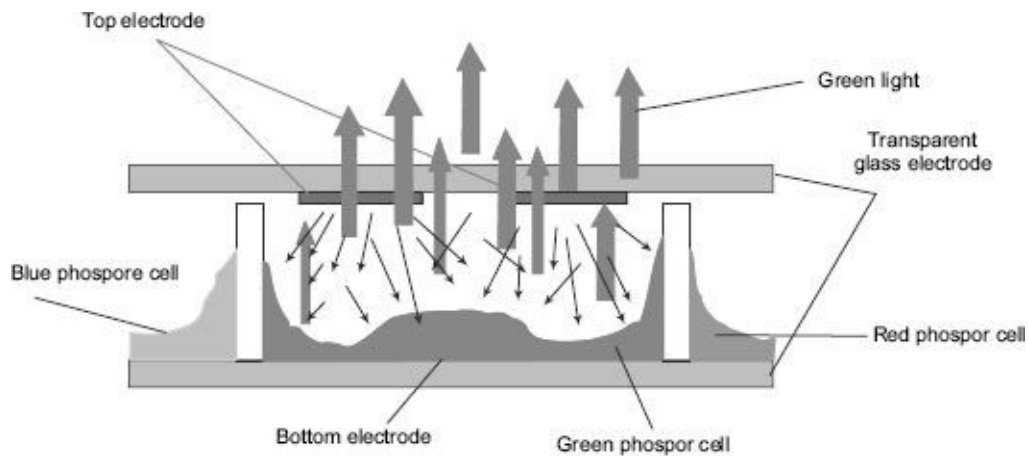

Figure 15.29 Working principle of plasma display

A plasma display panel is based on emitting light by exciting gases. The gas used in plasma screens is a mixture of argon (90%) and xenon (10%). Gas is contained within cells, each one corresponding to a pixel that corresponds to a row electrode and column electrode, which excite the gas within the cell. A typical green colour cell is shown in [Figure 15.29](#), where red and blue colour cells are located nearby. By modulating the voltage applied across the top and bottom electrodes and by changing the frequency of excitation, the inert gas can be excited. The gas excited this way produces ultraviolet radiation (which is invisible to the human eye). With blue, green, and red phosphors distributed among the cells, the ultraviolet radiation is converted into visible light, so that pixels (made up of 3 cells) can be displayed in up to 16 million colors ($256 \times 256 \times 256$).

Plasma technology can be used to create large-scale high-contrast screens, but plasma screens are still expensive. What's more, power consumption is more than 30 times higher than for an LCD screen. A typical plasma TV of SAMSUNG Corp. is shown in [Figure 15.30](#).



Figure 15.30 Plasma TV [Manf. SAMSUNG Corp.]

15.4.5 Nixie Tube

Nixie tubes are nonplanar electronic devices that use the principles of glow discharge for displaying numerals or other information. These are actually gaseous glow tubes made of glass that contain two electrodes. The anode is in the form of a wire mesh and multiple cathodes that are shaped as numerals or other symbols that are to be displayed. When the cathode corresponding to the numeral to be displayed is activated, it gets surrounded by an orange gaseous glow discharge. The glass tube is generally filled with neon gas at low pressure, with a little mercury. The photograph of a Nixie tube is shown in [Figure 15.31](#).

When a sufficient potential of around 170 volts is applied between the selected cathode and the anode plate, the gas surrounding the selected cathode gets ionised and emits an orange glow. A Nixie tube should not be confused with a vacuum tube since operation of the Nixie tube does not depend on thermionic emissions of electrons from a heated cathode. The operating temperature of Nixie tube rarely exceeds 40°C. Nixie tubes are thus also called cold-cathode tube.

The most commonly available Nixie tube has ten cathodes in the shapes of the numerals 0 to 9, and may be a decimal point. These cathodes displaying different numbers are arranged one behind another. Thus, when the characters glow one at a time, each character appears at a different depth.

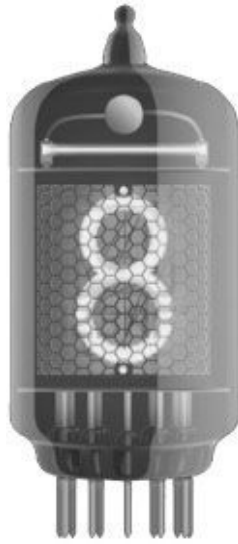

Figure 15.31 Nixie tube (Courtesy, www.123rf.com)

Nixie tubes were used in earlier days as display units in voltmeters, ammeters and other electrical and electronic measuring instruments.

EXERCISE

Objective-type Questions

1. A strip chart recorder is a/an
 - (a) analog recorder
 - (b) magnetic tape recorder
 - (c) oscillographic recorder
 - (d) none of the above
2. Printing mechanism of a FAX machine is of
 - (a) thermal type
 - (b) impact type
 - (c) electrostatic type
 - (d) optical type
3. Which is not the function of data loggers?
 - (a) Display
 - (b) Online analysis
 - (c) Reporting
 - (d) Control
4. The bandwidth of a magnetic tape recorder is
 - (a) higher than electronic recorder
 - (b) higher than strip chart recorder
 - (c) lower than strip chart recorder
 - (d) higher than ultraviolet recorder
5. Power consumption of an LED display is
 - (a) higher than LCD display
 - (b) lower than LCD display

- (c) almost equal to LCD display
 - (d) Approximately two lines higher than same size LCD
6. In a CRT, the electron beam is deflected by
 - (a) electric field
 - (b) magnetic field
 - (c) both magnetic and electric field
 - (d) gravitational field
 7. Servo mechanism is used in
 - (a) potentiometric type recorder
 - (b) galvanometric type recorder
 - (c) magnetic tape type recorder
 - (d) ultraviolet recorder
 8. The response time of CRT display is
 - (a) higher than LCD display
 - (b) lower than LCD display
 - (c) higher than plasma display
 - (d) lower than plasma display
 9. The gas used in plasma screens is a mixture of
 - (a) nitrogen and oxygen
 - (b) nitrogen and xenon
 - (c) argon and nitrogen
 - (d) argon and xenon
 10. Time scale of a strip chart recorder is controlled by
 - (a) controlling speed of the chart paper
 - (b) controlling the stylus drive mechanism
 - (c) controlling the range selector
 - (d) controlling the stylus

Answers						
1. (a)	2. (a)	3. (d)	4. (b)	5. (b)	6. (a)	7. (a)
8. (a)	9. (d)	10. (a)				

Short-answer Questions

1. Classify different types of recorders.
2. What are the different components of a strip chart recorder? Briefly discuss those.
3. Compare a potentiometric with galvanometric recorder.
4. State the working principle of ultraviolet recorders.
5. What are the advantages of a magnetic tape recorder over the other recording system?
6. Draw a functional block diagram of a data logger. Also discuss about each element.
7. Compare cold cathode display with hot cathode display.
8. How Does a simple black-and-white LCD display work?
9. State the working principle of plasma display.
10. How are characters displayed in an LED dot matrix display unit?

16.1**INTRODUCTION**

Rising costs and the inflexibility of hard-wired relay systems have stimulated the development of Programmable Logic Controllers (PLCs) as an alternative. The PLC can be defined as a user-friendly; microprocessor-based specialised equipment that carries out control functions of many types and levels of complexity for use in industry. Its purpose is to monitor crucial process parameters and adjust process operations accordingly. It can be programmed, controlled, and operated by users. PLCs use a programmable memory to store instructions and to implement functions such as logic, sequencing, timing, counting and arithmetic in order to control machines and processes. PLCs are designed to be operated by users with perhaps a limited knowledge of computer and computing languages. Generally, a PLC's operator draws the lines and devices of ladder diagrams with a keyboard into a display screen. Then, the resulting drawing is converted into computer machine language and run as a user program.

In a traditional industrial control system, all control devices are wired directly to each other according to how the system is supposed to operate. The PLC replaces the wiring between the devices. Thus, instead of being wired directly to each other, all equipment is wired to the PLC. Then, the control program inside the PLC provides the wiring connection between the devices. The control program is the computer program stored in the PLC's memory that tells the PLC what's supposed to be going on in the system. If anybody wants a PLC system to behave differently or to control a different process element, just the control program is required to change. In a traditional system, making this type of change would involve physically changing the wiring between the devices, a costly and time-consuming endeavour.

The existing push buttons, limit switches, and other command components continue to be used, and become input devices to the PLC. In like manner, the contactors, auxiliary relays, solenoids, indicating lamps, etc., become output devices controlled by the PLC. If one understands the interface between the hardware and the software, the transition to PLCs is relatively easy to accomplish.

16.2**ADVANTAGES OF PLCs**

PLCs have been gaining popularity on the factory floor and will probably remain predominant for some time to come. Most of this is because of the advantages they offer.

- Cost effective for controlling complex systems.

- Flexible and can be reapplied to control other systems quickly and easily.
- Computational abilities allow more sophisticated control.
- Trouble shooting aids make programming easier and reduce downtime.
- Reliable components make these likely to operate for years before failure.
- Expandability.
- Ability to withstand harsh environments.
- Small space requirements.
- PLC circuit's operation can be seen during the operation directly on a monitor.

16.3

THE CONTROL PROGRAM

A person knowledgeable in relay logic systems can master the major PLC functions in a few hours. These functions include coils, contacts, a timer and counters. The same is true for a person with a digital-logic background. For a person unfamiliar with digital and relay logics, however, the learning process takes more time. PLCs are not designed so that only computer programmers can set up or change the programs. Thus, the designers of the PLC have pre-programmed it so that the control program can be entered using a simple, rather intuitive form of language. So, the control program instructs the PLC system how to react to each input signal from, say, switches and give the required outputs to, say, lamps, motors and valves. A program might have a form as follows:

If switch *A* or *B* close

Then output to lamp circuit

If switch *A* and *B* close

Output to motor circuit

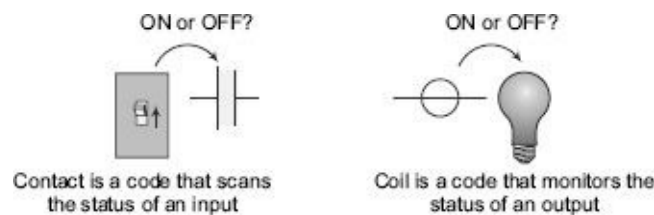

Figure 16.1 *Contacts and coils*

In a PLC, switches, sensors or input devices are realised as contacts and output circuits as coils. The term logic in a PLC is used because programming is primarily concerned with implementing logic and switching operations. Input devices such as sensors, switches and output devices in the system being controlled, e.g. lamp, motor etc., are connected to the PLC. The operator then enters a sequence of instructions, i.e. a control program, into the memory of the PLC. The controller then monitors the inputs (contacts) and outputs (coils) according to this control program and carries out the control rule for which it has been programmed.

16.4

FUNCTION OF EACH PART IN PLC

A PLC consists of the CPU, memory and circuits for inputs and outputs. Input and output circuits deal with receiving input data and sending data to output devices respectively. A PLC may be considered to be a collection of a large number of relays, counters, timers and data-storage locations. These components (timers, counters, etc.) do not exist physically but, are used as logical components. The block diagram of the internal structure of a PLC is shown in [Figure 16.2](#).

1. Input Relays (Contacts)

These components are actually transistors, exist physically and are meant for receiving signal from sensors, switches, etc.

2. Internal Utility Relays (Contacts)

They are logical (simulated) relays and are the main tools of a PLC which eliminate the use of conventional physical relays and finally, hard-wired relay control circuits. These are useful components to implement control logic programs.

3. Output Relays (Coils)

They do exist physically, made of transistors, conventional relay, etc., depending upon applications and are used to send on/off signals to lamps, solenoids etc.

4. Counters

These are programmed to count the number of events (pulses). They do not exist physically. These logical components are used for the sake of implementing control programs containing the need of counting up or down or both, a series of events.

5. Timers

These exist logically. These are used to introduce time delay between the occurrence of two events. Timers are of different types, like, on-delay timers, off-delay timers, retentive type, etc.

6. Data Storage

These are basically a group of registers, used to store data to carry out arithmetic and logical operations with them. This is a very essential part of a PLC.

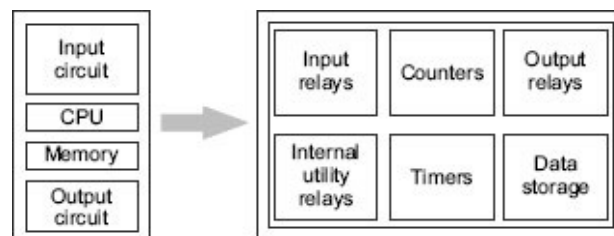

Figure 16.2 Block diagram of the internal structure of PLC

Typically, a PLC system has three basic functional components. The three major parts are central processing unit (CPU), Input/output module and programming terminals. [Figure](#)

16.3 shows how these three parts are interconnected.

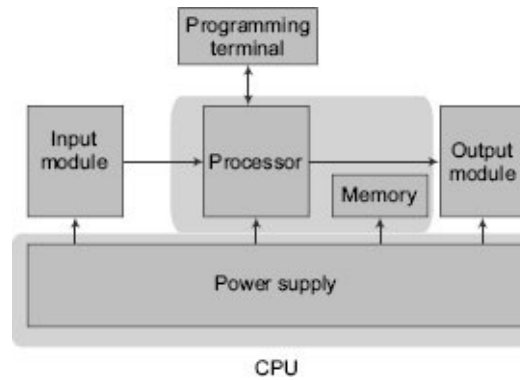

Figure 16.3 Block diagram of PLC hardware

16.5.1 The Central Processing Unit (CPU)

CPU controls and processes all the operations within the PLC. It is supplied with a clock frequency of typically between 1 and 8 MHz. This frequency decides the operating speed of a PLC and provides the timing and synchronisation for all elements in the system. The CPU acts as the “brain” of the system, which has three subparts:

1. Processor

It contains the microprocessor. This interprets the input signals and carries out mathematic and logic operations to set the control actions, according to the program stored in the memory, and finally, communicates the decisions as action signals to the output. This part does the following functions:

- (a) **Updating Inputs and Outputs** This function allows a PLC to read the status of its input terminals and activate or de-activate its output terminals.
- (b) **Performing Logic and Arithmetic Operations** For this an Arithmetic and Logic Unit (ALU) is there. It is responsible for data manipulation and carrying out arithmetic operations of addition and subtraction and logic operations of AND, OR, NOT, XOR.
- (c) **Communicating with Memory** As data and programs are stored in the memory, the CPU needs to communicate with the memory throughout the operation.
- (d) **Scanning Application Programs** The scanning function allows the PLC to execute the application program as specified by the programmer.
- (e) **Communicating with a Programming Terminal** The programming terminal is used to load programs and data into the CPU. So, in PLC programming mode, the CPU has to constantly communicate with the programming terminal.

A PLC uses four buses to carry out communication process when binary information is transferred from one location to another. Those buses are data bus, address bus, control bus and system bus.

- *Data bus* carries the data used in the processing carried out by the CPU. This is a bidirectional bus as the CPU has to perform both data/instruction read and write operation through this bus.
- *Address bus* used to carry the address of memory locations or I/O devices to identify a particular memory register or I/O device with which the read/write operation is

conducted by CPU.

- *Control bus* carries the signals used by the CPU for control actions, e.g. to inform memory devices whether they are to receive data from an input device or to send data to an output device. This bus is employed to carry timing signals used to synchronise actions.
- *System bus* is used for communications between the input/output ports and input/output units.

2. Memory

It is the area of the CPU in which data and information are stored and retrieved. It is there to hold the system software and user programs. As shown in Figure 16.4, the memory is used to store different files. *File* is the collection of words and a word has two bytes, *lower byte* and *higher byte*. Eight bits make a word. *Bit* is the smallest unit of information, either high or low. To store a bit, the smallest unit of memory is known as a *memory cell*. A *register* is a group of memory cells. For example, eight memory cells connected in parallel forms an eight-bit register. So, to store a word (2 bytes), two such registers are to be used. To identify memory locations, it is very essential to adopt an addressing scheme which may be octal or hexadecimal.

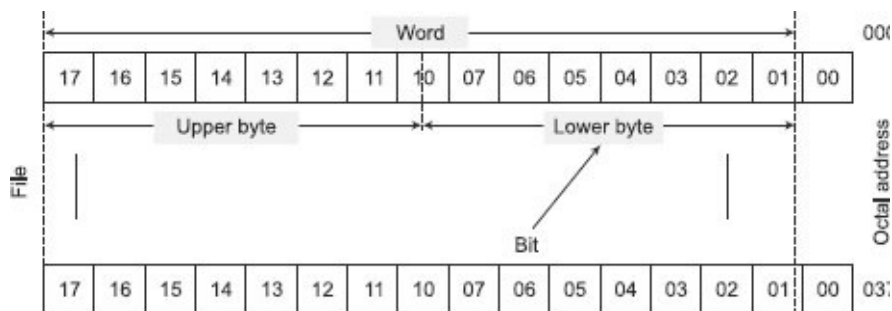

Figure 16.4 Bit, byte, word, file relationships

A PLC memory system has both ROM and RAM. PLC operating-system programs are stored permanently into ROM, whereas information can be stored and retrieved into/from the RAM. The programs and data in RAM can be changed by the user. However, to prevent the loss of programs when the power supply is switched off, a battery is used in the PLC to maintain the RAM contents for a period of time. User programs (say, ladder logic program) can be written into the RAM and a new program can overwrite previously written programs in the same locations. Apart from these possibly, as a bolt-on extra module, erasable and programmable read-only-memory (EPROM) is available and it can be programmed and then the program made permanent. After a program has been developed in RAM, it may be loaded into an EPROM memory and made permanent. In addition, there are temporary buffer storage for input/output modules. Memory capacity, often expressed in terms of kilo-bytes, can vary from PLC to PLC.

3. Power Supply

It is a section of CPU which converts ac line voltage to various operational dc values. The power supply makes regulated dc voltage with proper filtering circuit to ensure the supply of desired low dc voltage levels to the processor and circuits in the input and output modules.

16.5.2 The Input/Output (I/O) Modules

The input/output module provides the interface between the system and the outside world, allowing for connections to be made through input/output channels to input and output devices. The input module has terminals into which outside process electrical signals, generated by sensors or transducers, are fed. The output module has terminals to which output signals are sent to activate relays, solenoids, various solid-state switches, motors, indicators and displays. A very simple control scheme using a PLC has been shown in [Figure 16.5](#).

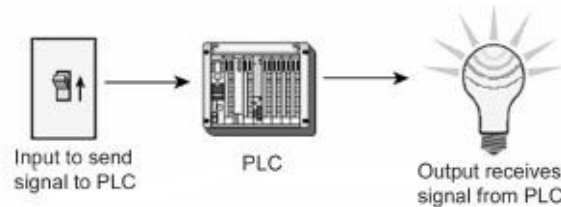

Figure 16.5 Input and output schemes in a PLC

It is also through the input/output module that programs are entered from a programming terminal. Every input/output point has a unique address which can be used by the CPU for identifying the device. The input/output channels provide isolation and signal-conditioning functions so that sensors and actuators can often be directly connected to them without the need for other circuitry. Electrical isolation from the external world is usually by means of opto-isolators (opto-coupler).

An electronic system for connecting I/O modules to remote locations can be added if needed. The actual operating process under PLC control can be hundreds of meters from the CPU and its I/O modules. Input and output devices can be classified as giving signals which are discrete or digital or analog as shown in [Figure 16.6](#). Analog devices give signals whose size is proportional to the size of the variable being monitored. For example, a variable potential divider has no definite on-state, i.e. signals coming from these types of devices may have any value in between off or zero (minimum) and on or one (maximum). Digital devices have two distinct states on and off and they can give a sequence of on-off signals.

Outputs are specified as being of *relay type*, *transistor type* or *triac type*.

For faster switching operation or response, *transistor-type* output is preferred over *relay-type* output. Off Relay-type output isolates the PLC from the external circuit. But in the transistor type, opto-isolators are used to provide isolation. *Triac* output with opto-isolator can be used to control external loads which are strictly connected to ac power supply.



Figure 16.6 Digital and analog devices

Outputs to actuators allow a PLC to cause something to happen in a process. Few popular actuators are solenoid, valves, lights/indicator (normally, to test designed logic circuits), motor starters, servomotors, etc. Typical examples of sensors used as inputs to

PLC are switches, potentiometers, LVDTs (Linear Variable Differential Transformers), etc.

The way in which dc devices are connected to a PLC can be described with the terms *sourcing* and *sinking*. With sourcing, using the conventional current-flow direction as from positive to negative, an input device receives current from the input module, i.e. the input module acts as the source of the current (Figure 16.7(a)). If the current flows from the output module to an output device or load, the output module is referred to as sourcing. [Figure 16.7(b)]. With sinking, using the conventional current-flow direction as from positive to negative, an input device is the sink for the current [Figure 16.7(c)]. If the current flows to the output module from an output device or load then the output module is referred to as sinking [Figure 16.7(d)].

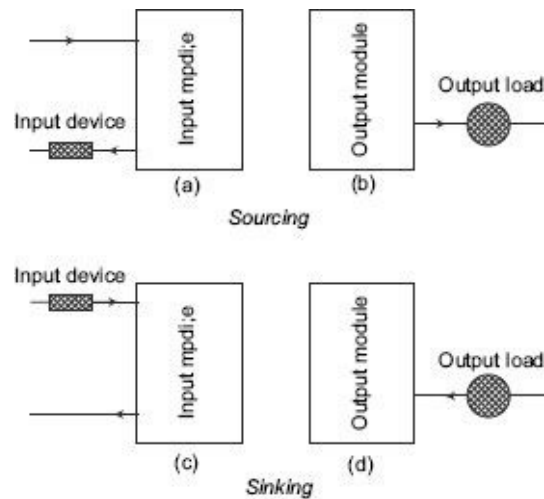

Figure 16.7 Sourcing and sinking of I/O devices

There are two common types of mechanical design for PLC systems; a single box, and the modular/ rack types. The single-box type (sometimes called *brick*) is commonly used for small programmable controllers and is supplied as an integral compact package complete with power supply, processor, memory, and input/output units. Typically, such a PLC might have 6, 8, 12 or 24 inputs and 4, 8 or 16 outputs. Some box or brick PLC systems have the options to extend more input and output by linking input/output boxes.

Systems with larger numbers of inputs and outputs are likely to be modular and designed to fit in racks. *Rack* is an enclosure with slots on which the CPU, power supply and I/O modules are mounted. The rack type can be used for all sizes of programmable controllers and has various functional units packaged in individual modules which can be plugged into slots according to requirement. Thus, it is comparatively easy to expand the number of inputs/outputs by just adding more I/O modules or to expand the memory by adding more memory units as shown in Figure 16.8.

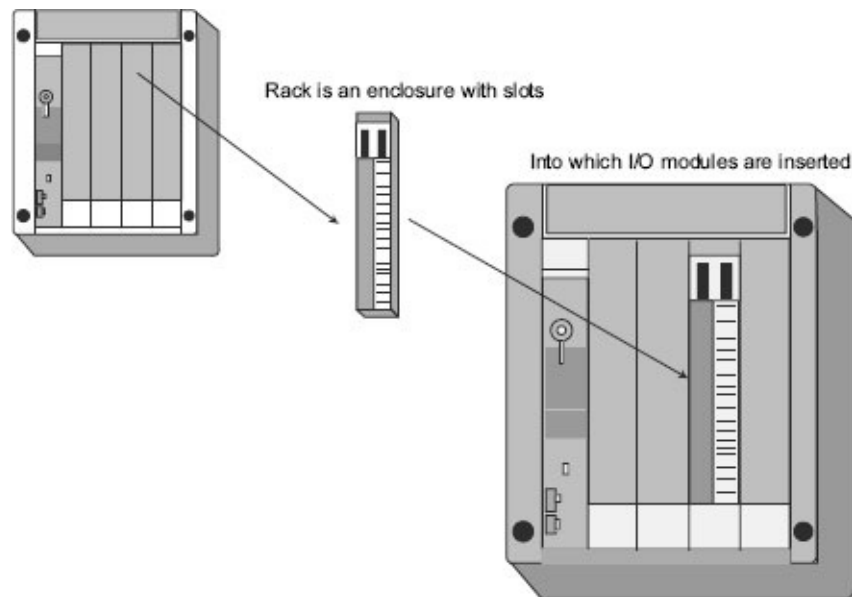

Figure 16.8 Rack and I/O module arrangement

16.5.3 PLC Programming Terminal

The programming terminal connects PLC programmer/monitor (PM) to CPU by a cable. PLC programming equipment exists to allow the user to write, edit and monitor a program, as well as perform various diagnostic procedures. PLC programming arrangements can be a hand-held device, a desktop console or a personal computer.

Hand-held programming will normally contain enough memory to allow the unit to retain programs while being carried from one place to another.

Desktop consoles are likely to have a visual display unit with a full keyboard.

Personal computers are widely configured as program development workstations. Some PLCs only require the computer to have appropriate software; others require special communication cards to interface with the PLC.

Every brand of PLC has its own programming hardware. Sometimes, it is a small hand-held device that resembles an oversized calculator with a Liquid Crystal Display (LCD). Computer-based programmers typically use a special communication board, installed in an industrial terminal or personal computer, with the appropriate software program installed. Computer-based programming allows offline programming, where the programmer develops his her logic, stores it on a disk, and then downloads the program to the CPU at his her convenience. In fact, it allows more than one programmer to develop different modules of the program. Programming can be done directly to the CPU if desired. When connected to the CPU, the programmer can test the system, and watch the logic operate as each element is intensified in sequence on the CRT when the system is running. Since a PLC can operate without having the programming device attached, and one device can be used to service many separate PLC systems. The programmer can edit or change the logic online in many cases.

The knowledge of addressing systems or schemes is a must to implement and execute a control program in a PLC. Input devices like push buttons, limit switches, etc., are to be connected with the controller to feed input commands and then execution of the control program brings the results out through output devices like motor starters, solenoids, and light bulbs, etc., connected with the system. Inputs and outputs are wired to interface modules, installed in an I/O rack. Normally, each rack has a two-digit address, each slot has its own address, and each terminal point is numbered.

16.6.1 I/O Addresses

At the time of relay logic or ladder-diagram implementation, all input and output devices connected with the PLC are identified by unique addresses. As it has already been discussed, I/O modules are kept in the rack. In a PLC system, each rack can be identified by a two-digit address. In each rack, slots are there to place input and output cards. Again, the slots are numbered (say, 0 to 7). For example, assuming an input card has eight input channels which are numbered (00 to 07). Now, as shown in Figure 16.9, in a typical PLC, to connect two switches (one push button and another temperature switch) with the input card, placed in slot 3 of rack 01, two channels or terminals of that input card are to be used (say, 01 and 03). So, the assigned address to the push-button switch becomes I:013/01 and for the temperature sensor, is I:013/03. More precisely, in an input/output device address, the first alphabet indicates device type ('I' for input device or 'O' for output device) followed by a colon (:), and then, the next two digits indicate the rack number followed by the slot number and after a slant (/), the terminal number or bit number.

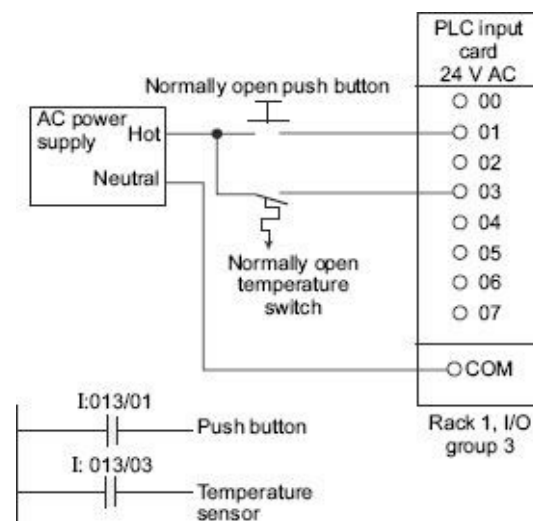

Figure 16.9 An input card and ladder logic

16.6.2 Image Table Addresses

As shown in Figure 16.10, in a PLC system, one file is reserved as an input image table. Every word in that file has a three-digit octal address beginning with 1:, which can be interpreted as the letter I for input. The word addresses start with octal 1:000 to 1:017 (or higher). This number is also followed by a slant (/) and the 2-digit bit number.

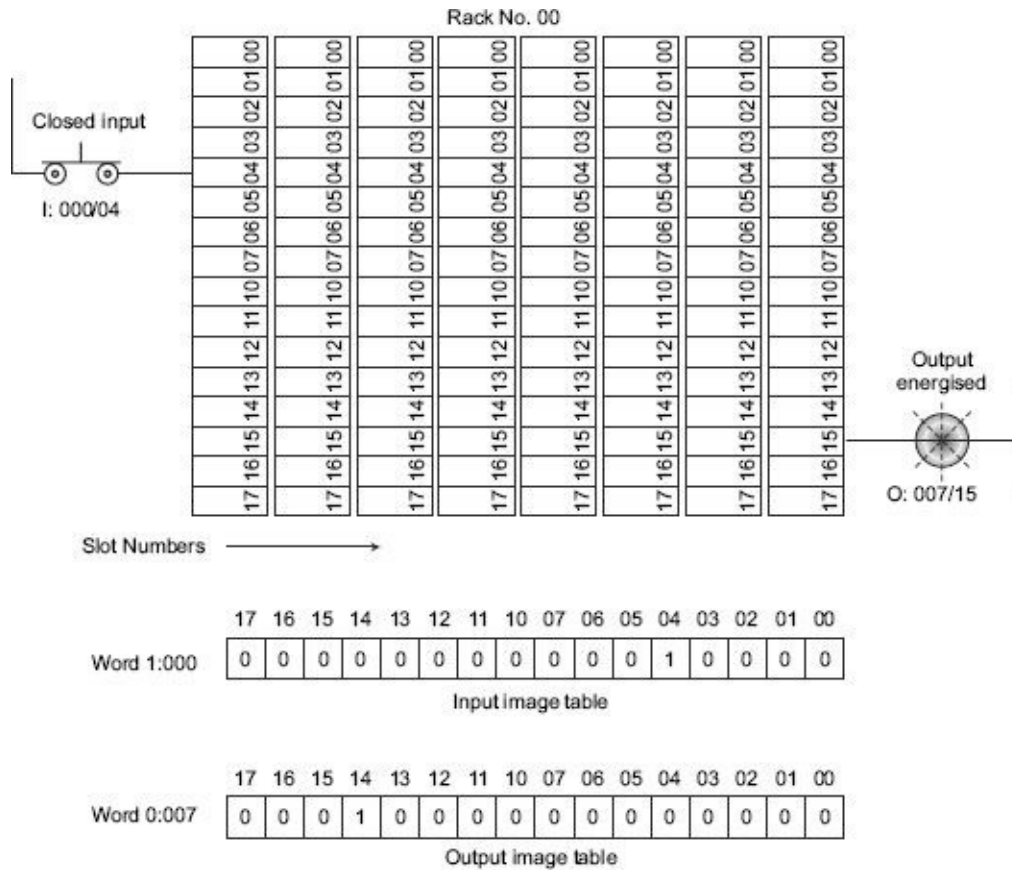

Figure 16.10 Solution of one line of logic

In Figure 16.10, the input address I:000/04, becomes memory address I:000/04, and the output address 0:007/14 becomes memory address 0:007/14. In other words, type of module, rack address, and slot position identify the word address in memory. The terminal number identifies the bit number.

16.6.3 Remote I/O

So far it has been assumed that a PLC consists of a CPU, power-supply unit, and a collection of I/O cards mounted in the local rack. In the early days, PLCs did tend to be arranged like this, but in a large and scattered plant with this arrangement, all signals have to be brought back to some central point using expensive multicore cables. It will also make commissioning and fault finding more difficult, as signals can only be monitored effectively at a point possibly some distance from the device being tested.

PLC manufacturers, therefore, provide the ability to mount I/O racks remote from the processor, and link these racks with simple and cheap screened pair of fibre optic cables. If remote I/O is used, provision should be made for a program terminal to be connected local to each rack. Remote I/O allows complete units to be built, wired to a built-in rack, and tested offsite prior to delivery and installations. Figure 16.11 shows three remote racks, and connects to the controlling PLC mounted in a substation far away, via a remote I/O cable, plus a few power supplies and hardware safety signals.

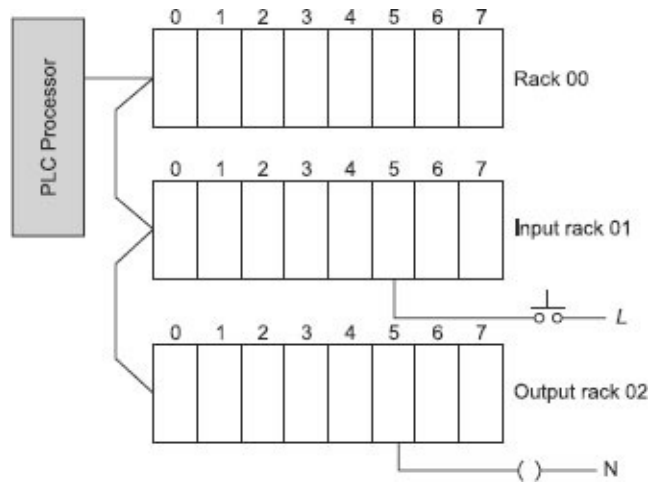

Figure 16.11 Remote I/O racks

16.7

PLC OPERATION AND PROGRAM SCAN

A PLC program can be considered to behave as a permanent running loop as shown in Figure 16.12(a). The actions carried out by a PLC shown in Figure 16.12(a) is called *program scan*, and the period of the loop is called *program scan time*. This depends on the size of the PLC program and the speed of the processor.

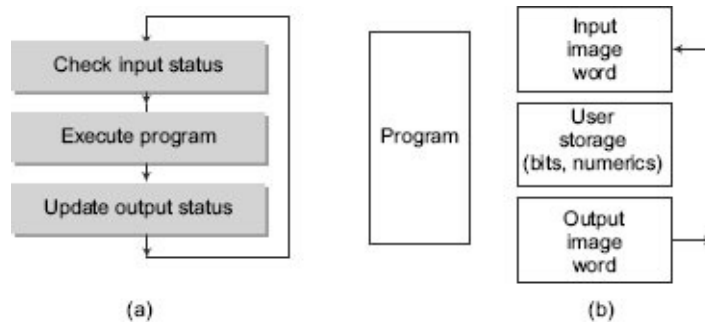

Figure 16.12 Three steps in PLC operation

At start, the PLC scans the state of all the connected inputs and stores their states in the PLC memory. When PLC program accesses an input, it reads the input state as it was at the start of the program scan. A zone of PLC memory corresponding to the outputs is changed by the execution of the program, and then, all the outputs are updated simultaneously at the end of the scan. The action is thus *read inputs, execute program, update outputs*. Therefore, a PLC does not communicate continuously with the outside world.

PLC memory can be considered to consist of four zones or areas as shown in Figure 16.12(b). The inputs are read into the input mimic area at the start of the scan called *input image word* (explained earlier), and the output updated from the *output mimic zone* or area called output image word at the end of the scan. There will be an area in the memory reserved for internal signals which are used by the program but are not connected directly to the outside world (timers, counters, latches, etc.). These three areas are often referred to as data table or database. As indicated in Figure 16.13, total response time is the sum of input response time, program execution time and output response time.

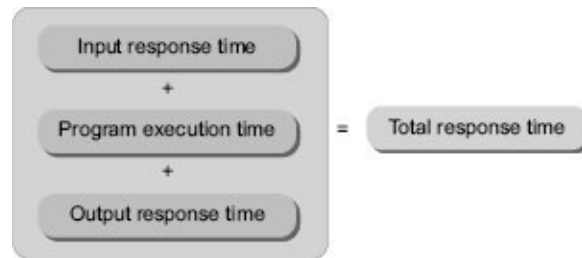

Figure 16.13 *PLC response time*

16.8

IMPLEMENTATION OF CONTROL PROGRAMS IN PLC

PLCs from different manufacturers can be programmed in various ways. Popular programming languages for PLCs are ladder diagrams, Function Block Diagrams (FBD), and statement list. With a few exceptions, a program written in one format can be viewed in another.

16.8.1 Ladder Diagrams

As an introduction to ladder diagram, consider the simple relay circuit which contains a coil and contacts as shown in [Figure 16.14](#). When a voltage is applied to the input coil, the resulting current creates a magnetic field. The magnetic field pulls a metal switch (or reed) towards it and the contacts touch, closing the switch. The contact that closes when the coil is energised is called normally open (NO). The Normally Closed (NC) contacts touch when the input coil is not energised. When the input coil is not energised, the normally closed contacts will be closed (conducting). The relay shown in the figure has two contacts; one NO another NC. When the relay coil is energised, contacts of the relay change their state, i.e. NO contacts get closed and NC contacts get opened. The relay arrangement can be shown with the help of different schematic circuits as shown in [Figure 16.14](#). Relays are normally drawn in a schematic form using a circle to represent the input coil. The output contacts are shown with two parallel lines. NO contacts are shown as two lines, and will be open (nonconducting) when the input is not energised. NC contacts are shown with two lines with a diagonal line through them. Now, if it is required to operate NO (C) contact of this relay, connected to an ac source, through two input relay contacts, A (NC) and B (NO) then the relay logic diagram shown in [Figure 16.15](#) is the most appropriate for a typical logic. According to the relay logic diagram shown in the figure, activation of the input relay coil corresponds to the contact B, makes C (output) closed and activation of the input relay coil corresponds to the contact A, makes C (output) to get opened. This sort of arrangement is normally employed in conventional hard-wired relay logic circuit.

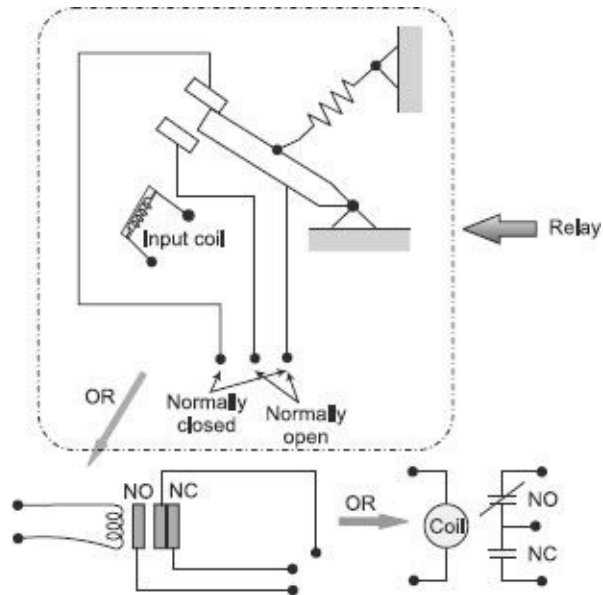

Figure 16.14 Simple relay layouts and schematics

The same scheme can be implemented following ladder logic as shown in [Figure 16.15](#). The ladder logic-diagram is the most commonly used method of programming PLCs. The ladder diagram consists of two vertical lines representing the power rails. Circuits connected as horizontal lines between two rails are called rungs of the ladder. Few symbols used to denote ladder logic inputs and outputs are shown in [Figure 16.16](#) and [16.17](#) respectively. Taking into consideration these ladder logic symbols, the ladder logic implemented in [Figure 16.15](#) mimics the same hard-wired relay logic. Finally, this ladder logic is inserted as a control program to a PLC where, input devices, and output devices are arranged in a fashion as illustrated in [Figure 16.18](#). So, the ladder-logic programs are loaded into the PLC, the input and output devices are connected to I/O modules and then the execution of the program updates outputs according to the status of inputs.

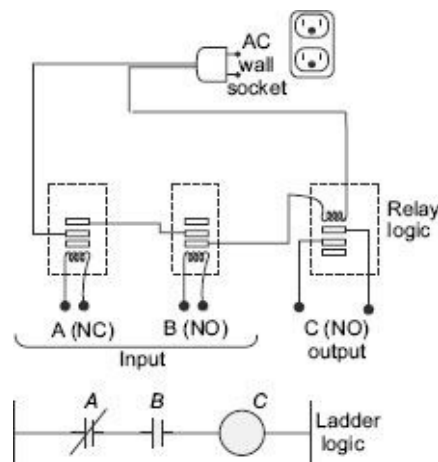

Figure 16.15 A simple relay controller and corresponding ladder-logic

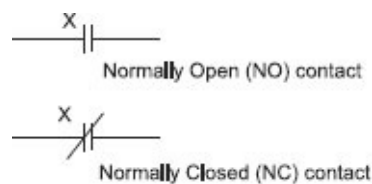

Figure 16.16 Ladder logic inputs



Figure 16.17 Ladder logic Normal Output

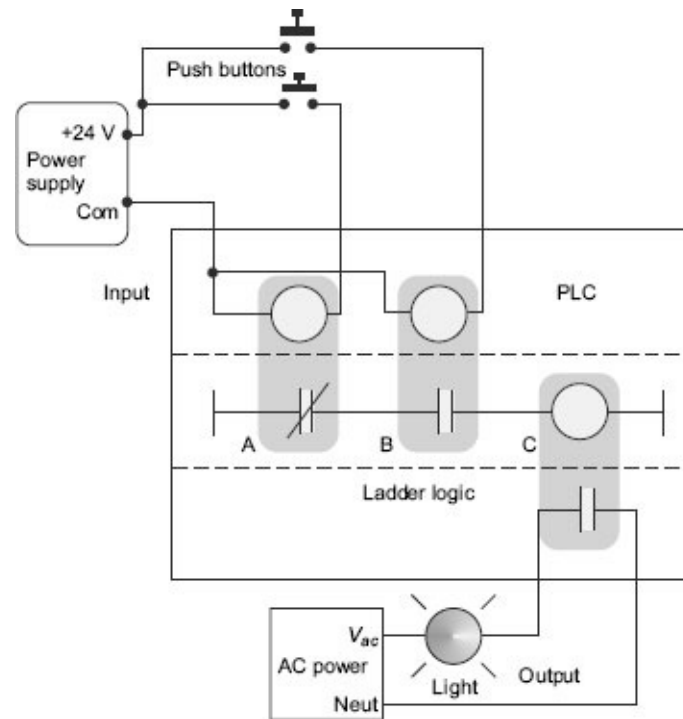

Figure 16.18 A PLC illustrated with relays

Many relays also have multiple outputs and this allows an output relay to also be an input simultaneously. The circuit shown in [Figure 16.19](#) is an example of this and it is called a *seal-in circuit*. In this circuit, the current can flow through either branch of the circuit, through the contacts labelled A or B. The input B will only be on when the output B is on. If B is off, and A is energised then B will turn on. If B turns on then the input B will turn on, and keep output B on even if input A goes off. After B is turned on, the output B will not turn off.

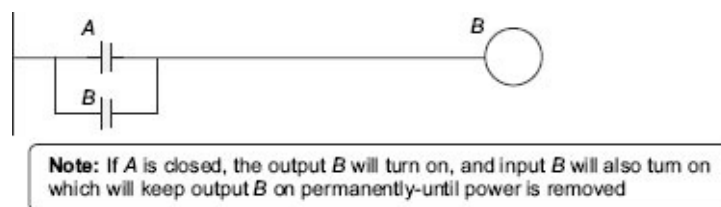

Figure 16.19 A seal-in circuit

Another example of ladder logic can be seen in [Figure 16.20](#). To interpret this diagram, imagine that the power is on the vertical line on the left-hand side, called hot rail. On the right-hand side is the neutral rail. In the figure there are two rungs, and on each rung there are combinations of inputs (two vertical lines) and outputs (circles). If the inputs are opened or closed in the right combination, the power can flow from the hot rail, through the inputs, to power the outputs, and finally to the neutral rail. An input can come from a sensor, switch, or any other type of sensor. An output will be some device outside the PLC that is switched on or off, such as lights or motors. In the top rung, the contacts are normally open and normally closed, which means if input A is on and input B is off then power will flow through the output and activate it. Any other combination of input values will result in the output X being off.

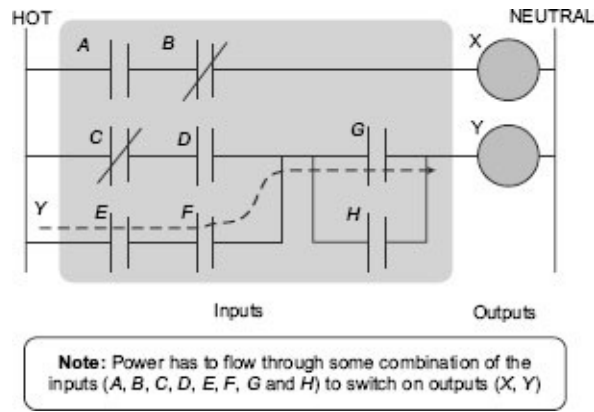

Figure 16.20 A simple ladder logic diagram

Example 16.1

Try to develop (without looking at the solution) a relay-based controller that will allow three switches in a room to control a single light.

Solution There are two possible approaches to this problem. The first assumes that any one of the switches on will turn on the light, but all three switches must be off for the light to be off. The ladder logic is shown in Figure 16.21.

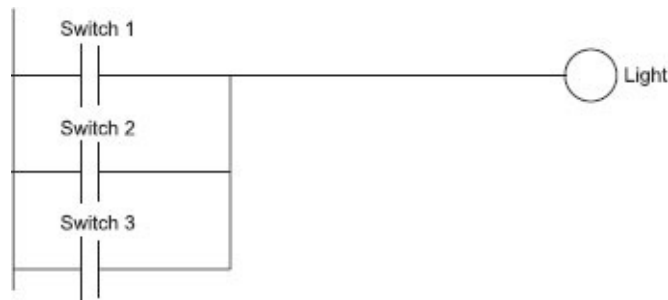

Figure 16.21 Ladder logic to controlling one light with three switches

The second solution assumes that each switch can turn the light on or off, regardless of the states of the other switches. This method is more complex and involves thinking through all of the possible combinations of switch positions. You might recognise this problem as an exclusive or problem. The ladder logic is as shown in Figure 16.22.

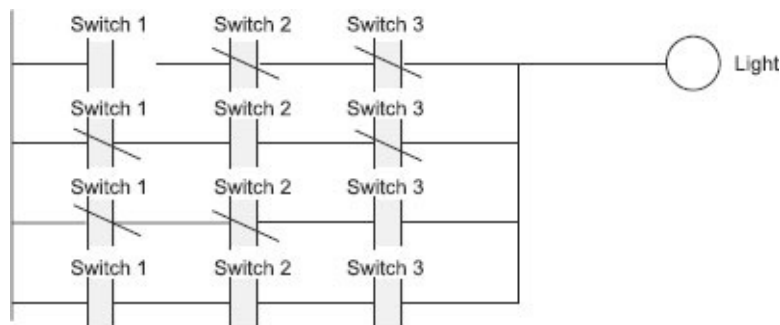

Figure 16.22 Ladder logic to controlling one light in a different way with three switches

Note: It is important to get a clear understanding of how the controls are expected to work. In this example, two radically different solutions were obtained based upon a simple difference in the operation.

16.8.2 Function Block Diagram

Function Block diagram (FBD) is used for PLC programs described in terms of graphical

blocks. It is described as being a graphical language for depicting signal and data flows through ^{Inputs} blocks, these being reusable software elements. A function block is a program instruction unit which, when executed, yields one or more output values. Thus, a block is represented in a manner shown in [Figure 16.23](#) with the function name written in the block. Functional blocks can have standard functions, such as those of the logic gates or counter or timers or have functions defined by the user, e.g. a block to obtain an average value of inputs.



Figure 16.23 Function block

16.8.3 Statement List

In statement-list programming approach, an instruction set similar to assembly language for a microprocessor is used. Statement lists, available on few brands of PLCs, are the most flexible form of programming for the experienced user but are by no means as easy to follow as ladder diagrams or logic symbols.

[Figure 16.24](#) shows a simple operation in ladder-diagram form for a Mitsubishi PLC. The equivalent statement list would be as shown in [Table 16.1](#).

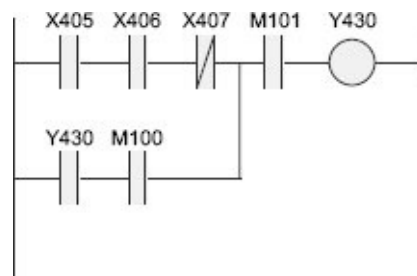

Figure 16.24 Mitsubishi ladder diagram

Table 16.1 Equivalent statement list for [Figure 16.24](#)











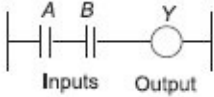

Line	Instruction	Comment
0	LD X405	LD starts rung or branch
1	AND X406	Xnnn are inputs (AND-ing is for series connection)
2	ANI X407	ANI is AND with not
3	LD Y430	LD starts a new branch leg
4	ANI M100	Mnnn are internal storage
5	ORB	OR the two branch legs (OR-ing for parallel connection)
6	AND M101	
7	OUT Y430	End of rung with output

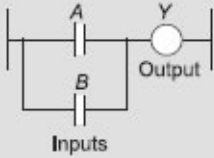
16.8.4 Logic Functions

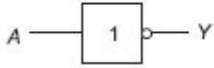
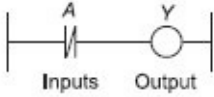
There are many control situations requiring actions to be initiated when a certain combination of conditions is realised. Thus, for an automatic drilling machine, there might be a condition that the drill motor is to be activated when limit switches are activated that indicate the presence of the workpiece and the drill position as being at the surface of the workpiece. Such situation involves the AND logic function, condition A and condition B

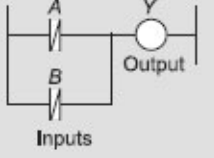
having both to be satisfied for an output to occur. Similarly, other situations may demand to implement logics like OR, NOT, NAND, NOR, XOR. The electric circuit, truth table, ladder diagram and functional block diagram for different logics are presented in [Table 16.2](#).

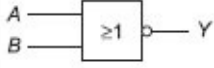
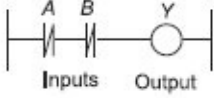
Table 16.2 Characteristics for different logics

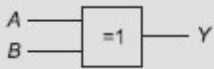
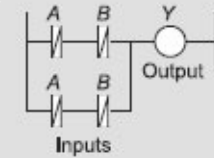
Logic	Logic Symbol	Truth Table	Functional Block diagram	Ladder Logic															
AND		<table border="1"> <thead> <tr> <th>A</th> <th>B</th> <th>Y</th> </tr> </thead> <tbody> <tr> <td>0</td> <td>0</td> <td>0</td> </tr> <tr> <td>0</td> <td>1</td> <td>0</td> </tr> <tr> <td>1</td> <td>0</td> <td>0</td> </tr> <tr> <td>1</td> <td>1</td> <td>1</td> </tr> </tbody> </table>	A	B	Y	0	0	0	0	1	0	1	0	0	1	1	1		
A	B	Y																	
0	0	0																	
0	1	0																	
1	0	0																	
1	1	1																	
OR		<table border="1"> <thead> <tr> <th>A</th> <th>B</th> <th>Y</th> </tr> </thead> <tbody> <tr> <td>0</td> <td>0</td> <td>0</td> </tr> <tr> <td>0</td> <td>1</td> <td>1</td> </tr> <tr> <td>1</td> <td>0</td> <td>1</td> </tr> <tr> <td>1</td> <td>1</td> <td>1</td> </tr> </tbody> </table>	A	B	Y	0	0	0	0	1	1	1	0	1	1	1	1		
A	B	Y																	
0	0	0																	
0	1	1																	
1	0	1																	
1	1	1																	
NOT		<table border="1"> <thead> <tr> <th>A</th> <th>Y</th> </tr> </thead> <tbody> <tr> <td>0</td> <td>1</td> </tr> <tr> <td>1</td> <td>0</td> </tr> </tbody> </table>	A	Y	0	1	1	0											
A	Y																		
0	1																		
1	0																		
NAND		<table border="1"> <thead> <tr> <th>A</th> <th>B</th> <th>Y</th> </tr> </thead> <tbody> <tr> <td>0</td> <td>0</td> <td>1</td> </tr> <tr> <td>0</td> <td>1</td> <td>1</td> </tr> <tr> <td>1</td> <td>0</td> <td>1</td> </tr> <tr> <td>1</td> <td>1</td> <td>0</td> </tr> </tbody> </table>	A	B	Y	0	0	1	0	1	1	1	0	1	1	1	0		
A	B	Y																	
0	0	1																	
0	1	1																	
1	0	1																	
1	1	0																	
NOR		<table border="1"> <thead> <tr> <th>A</th> <th>B</th> <th>Y</th> </tr> </thead> <tbody> <tr> <td>0</td> <td>0</td> <td>1</td> </tr> <tr> <td>0</td> <td>1</td> <td>0</td> </tr> <tr> <td>1</td> <td>0</td> <td>0</td> </tr> <tr> <td>1</td> <td>1</td> <td>0</td> </tr> </tbody> </table>	A	B	Y	0	0	1	0	1	0	1	0	0	1	1	0		
A	B	Y																	
0	0	1																	
0	1	0																	
1	0	0																	
1	1	0																	
XOR		<table border="1"> <thead> <tr> <th>A</th> <th>B</th> <th>Y</th> </tr> </thead> <tbody> <tr> <td>0</td> <td>0</td> <td>0</td> </tr> <tr> <td>0</td> <td>1</td> <td>1</td> </tr> <tr> <td>1</td> <td>0</td> <td>1</td> </tr> <tr> <td>1</td> <td>1</td> <td>0</td> </tr> </tbody> </table>	A	B	Y	0	0	0	0	1	1	1	0	1	1	1	0		
A	B	Y																	
0	0	0																	
0	1	1																	
1	0	1																	
1	1	0																	

16.9

MORE IN LADDER LOGIC

Combinational logic alone is not enough to implement control programs for more complex systems, especially, those with event-based devices. The example of such event-based system is illustrated in [Figure 16.25](#) with a timing diagram. The input to the device is a push button. When the push button is pushed, the input to the device turns on. If the push button is then released and the device turns off, it is a logical device. If when the push

button is released and the device stays on, it will be a type of event-based device. To reiterate, the device is event based if it can respond to one or more things that have happened before. If the device responds only one way to the immediate set of inputs, it is logical. To implement such event-based devices in ladder logic diagrams, some components are available in PLC programming approach. Latches, timers, counters are the most frequently used components used in ladder diagrams.

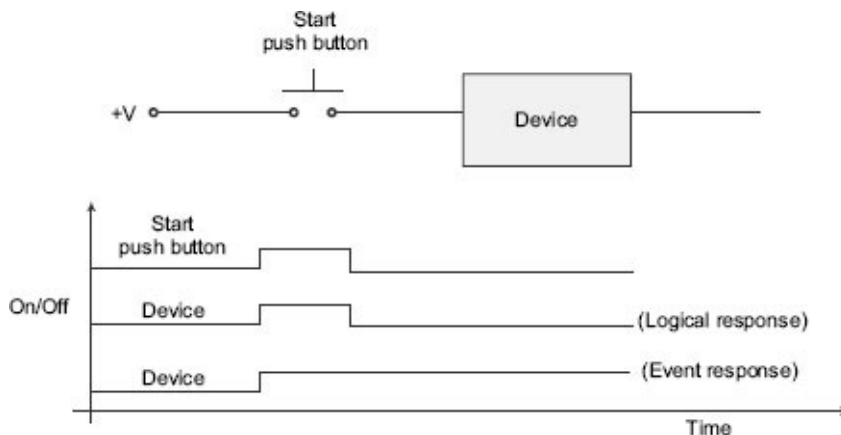

Figure 16.25 An event driven device

16.9.1 Latches or Set-reset Coils

Another function which is often available is the ability to latch and unlatch (set and reset) an internal relay. A latch is just like a sticky switch—when pushed, it will turn on and will continue with its on-state, it must be pulled to release it and turn it off. A latch in ladder logic uses one instruction to latch, and a second instruction to unlatch, as shown in Figure 16.26. The output with an *L* inside will turn the output *D* on when the input *A* becomes true. *D* will stay on even if *A* turns off and this makes *C* to turn off. Output *D* will turn off if input *B* becomes true and the output with a *U* inside becomes true. If an output has been latched on, it will keep its value, even if the power has been turned off.

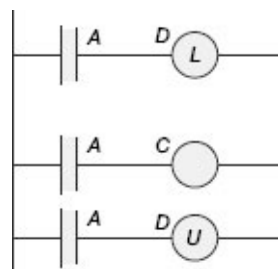

Figure 16.26 A ladder logic latch

16.9.2 Timers

The most commonly used process-control device after coils and contacts is the timer. There are four fundamental types of timers as illustrated in Table 16.3. A single input timer, called a *non-retentive timer*, is used in some PLCs. An example of such a timer is shown in Figure 16.27. Energising IN001 causes the timer to run for 8 seconds. At the end of 8 seconds, the output goes on. An *on-delay timer* will wait for a set time after a line of ladder logic has been true before turning on, but it will turn off immediately. An *off-delay timer* will turn on immediately when a line of ladder logic is true, but it will delay before turning off. An on-delay timer can be used to allow an oven to reach a certain temperature before starting production. An off-delay timer can keep cooling fans on for a set time after

the oven has been turned off.

Table 16.3 Four basic timer types

	On-delay	Off-delay
Non-retentive	On-delay timer (TON)	Off-delay timer (TOF)
Retentive	Retentive on-delay timer (RTO)	Retentive off-delay timer (RTF)



Figure 16.27 Single-input timer

A retentive timer will sum all of the on or off time for a timer, even if the timer is never finished. A nonretentive timer will start timing the delay from zero each time. Typical applications for retentive timers include tracking the time before maintenance is needed. A non retentive timer can be used for a start button to give a short delay before a conveyor begins moving.

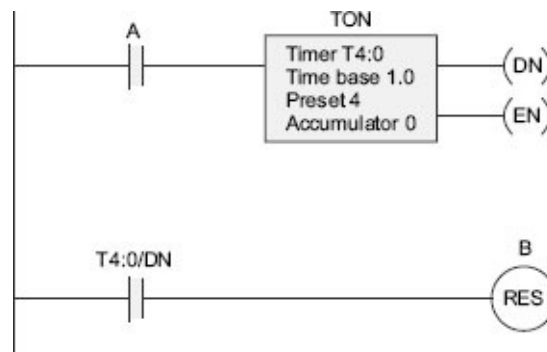

Figure 16.28 Example of TON timer

An example of a TON timer is shown in [Figure 16.28](#). The rung has a single input A and a function block for the TON. (Note: This timer block will look different for different PLCs, but it will contain the same information.) The information inside the timer block describes the timing parameters. The first item is the timer number T4:0 (or address). This is a location in the PLC memory that will store the timer information. The T4: indicates that it is timer memory, and the 0 indicates that it is in the first location. The time base is 1.0 indicating that the timer will work in 1.0 second intervals. Other time bases are available in fractions and multiples of seconds. The preset is the delay for the timer, in this case it is 4. To find the delay time, multiply the time base by the preset value $4 \times 1.0 \text{ s} = 4.0 \text{ s}$. The accumulator value gives the current value of the timer as 0. While the timer is running, the accumulated value will increase until it reaches the preset value. Whenever the input A is true, the EN output will be true. The DN output will be false until the accumulator has reached the preset value. The EN and DN outputs cannot be changed when programming, but these are important when debugging a ladder-logic program. The second line of ladder logic uses the timer DN output to control another output B.

16.9.3 Counters

There are two basic counter types: count-up and count-down. When the input to a *count-up counter* goes true, the accumulator value will increase by 1 (no matter how long the input is true.) If the accumulator value reaches the preset value, the counter DN bit will be

set. A *count-down counter* will decrease the accumulator value until the preset value is reached.

A count-up (CTU) instruction is shown in [Figure 16.29](#). The instruction requires memory in the PLC to store values and status, in this case, it is C4:0. The C4: indicates that it is counter memory, and the 0 indicates that it is the first location. The preset value is 4 and the value in the accumulator is 2. If the input A goes from false to true, the value in the accumulator would increase to 3. If A is turned off, then on again the accumulator value would increase to 4, and the DN bit would turn on. The count can continue above the preset value. If input B goes true the value in the counter accumulator will become zero.

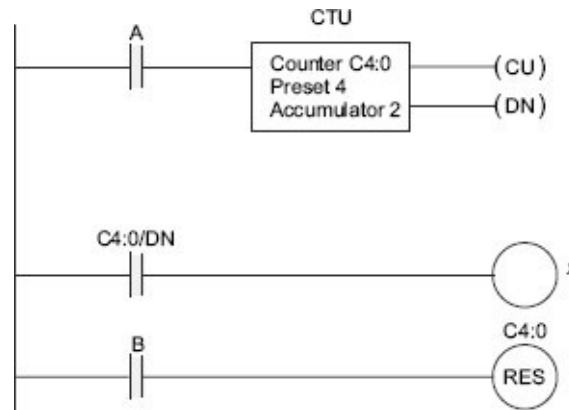

Figure 16.29 CTU counter

16.9.4 Master Control Relays (MCRs)

Master Control Relay (MCR) function is a powerful programming tool. When MCR is enabled, the ladder diagram functions normally. When it is not enabled, a specific number of coils and functions are frozen in the off position. Coils in the frozen section will remain off even if their corresponding enable lines are turned on. In an electrical control system, a master control relay is used to shut down a section. A section of ladder logic can be put between two lines containing MCRs. When the first MCR coil is active, all of the intermediate ladder logic is executed up to the line with another MCR coil. When the first MCR coil is inactive, the ladder logic is still examined, but all of the outputs or coils are forced off.

Take the example in [Figure 16.30](#). If A is true then the ladder logic is executed normally. But, if A is false, the following ladder logic will be examined, but all of the outputs will be forced off. The second MCR function appears on a line by itself and marks the end of the MCR block. After the second MCR, the program execution returns to normal mode. In this example, while A is true, condition of X will equal to B. As Y is a latch, it can be turned on by C, and can be turned off by D. But, if A becomes false, X will be forced off, and Y will continue with its last state. Using MCR blocks to remove sections of programs will not increase the speed of program execution significantly because the logic is still examined.

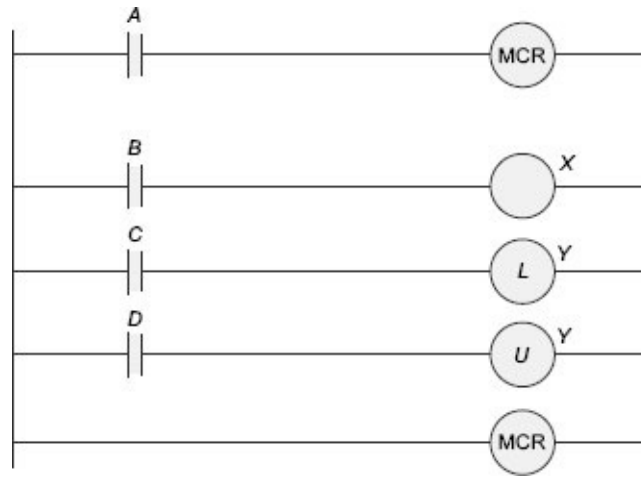

Figure 16.30 MCR instructions

16.9.5 More Examples on Timers and Counters

Example 16.2

Develop the ladder logic that will turn on an output light, 15 seconds after the switch A has been turned on.

Solution The ladder diagram for this problem is shown in Figure 16.31. An on-delay timer block with 15-second delay has been used and it is being activated by the switch A, and the contact present in the second rung is closed to turn on the light when the 15-second delay is elapsed.

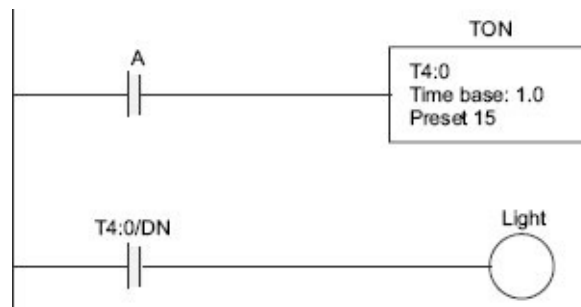

Figure 16.31 A simple timer example

Example 16.3

Develop the ladder logic that will turn on a light, after the switch A has been closed 10 times. Push button B will reset the counters.

Solution The ladder diagram to implement this logic is shown in Figure 16.32 where the up-counter block keeps the count of pressing the switch A. When the count reaches the preset value of the counter, the contact C5 in the second rung, corresponding to the counter, is closed and the light is turned on. To reset the counter the reset coil of the counter is energised by the switch B present in third rung.

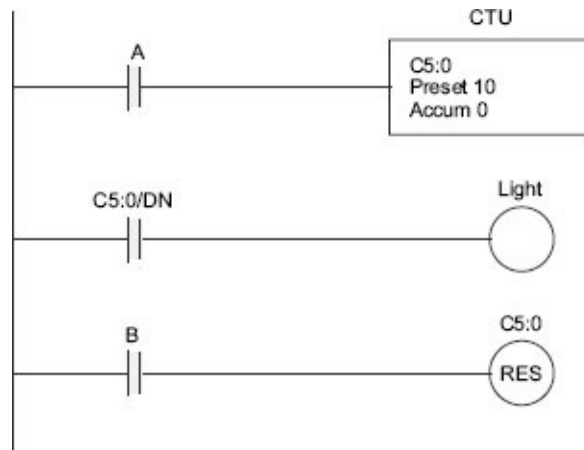

Figure 16.32 A simple counter example

EXERCISE

Objective-type Questions

1. PLCs are _____ designed for use in the control of a wide variety of manufacturing machines and systems.
 - (a) special-purpose industrial computers
 - (b) personal computers
 - (c) electromechanical systems
 - (d) all of the above
2. The first company to build PLCs was
 - (a) general motors
 - (b) Allen Bradley
 - (c) square D
 - (d) Modicon
3. Which of the following statements is not correct?
 - (a) The PLC rung output [-(-)] is a discrete output instruction or bit in memory.
 - (b) Each rung of the ladder logic represents a logical statement executed in software—inputs on the right and outputs on the left.
 - (c) Input and output instructions in ladder logic do not directly represent the switches and actuators.
 - (d) PLC input instructions are logical symbols associated with voltage at the input module terminals.
4. Which of the following statements is NOT correct?
 - (a) The status of each input can be checked from one location and outputs can be forced on and off.
 - (b) All symbols in the RLL represent actual components and contacts present in the control system.
 - (c) PLCs are not as reliable as electromechanical relays in RLL.
 - (d) Input (-|-) and output (- () -) instruction symbols in the ladder logic represent only data values stored in PLC memory.
5. When a relay is NOT energised,
 - (a) there is an electrical path through the NO contacts
 - (b) there is an electrical path through the NC contacts
 - (c) neither the NO or the NC contacts have an electrical path
 - (d) both the NO and the NC contacts have an electrical path

Answers

1. (a)

2. (d)

3. (d)

4. (c)

5. (c)

Short-answer Questions

1. Can a PLC input switch a relay coil to control a motor?
2. Develop a simple ladder logic program that will turn on an output X if any one of the inputs A , B and C is on.
3. Develop a simple ladder logic program that will turn on a motor operated by the output X if the input A is on and motor will turn off if the input B is on.
4. What are the benefits of input/output modules of a PLC?
5. How do input and output cards act as an interface between the PLC and external devices?

Long-answer Questions

1. Give a concise description of hardware of a PLC.
2. Draw a block diagram showing in very general terms the main units in a PLC.
3. Why would relays be used in place of PLCs? Give an example of where a PLC could be used. List the advantages of a PLC over relays.
4. Explain why ladder logic outputs are coils. Develop a simple ladder logic program that will turn on an output X if inputs A and B , or input C is on.
5. Can a PLC input switch a relay coil to control a motor? How do input and output cards act as an interface between the PLC and external devices? What are the benefits of input/output modules?
6. Explain why a stop button must be normally closed and a start button must be normally open. Explain the trade-offs between relays and PLCs for control applications.

17.1

INTRODUCTION TO RF AND WIRELESS COMMUNICATION SYSTEM

Radio frequency (RF) is any frequency within the electromagnetic spectrum associated with radio-wave propagation. When an RF current (input signal) is supplied to an antenna, an electromagnetic field is created that is then able to propagate through space. RF field propagation technology is used in many wireless technologies.

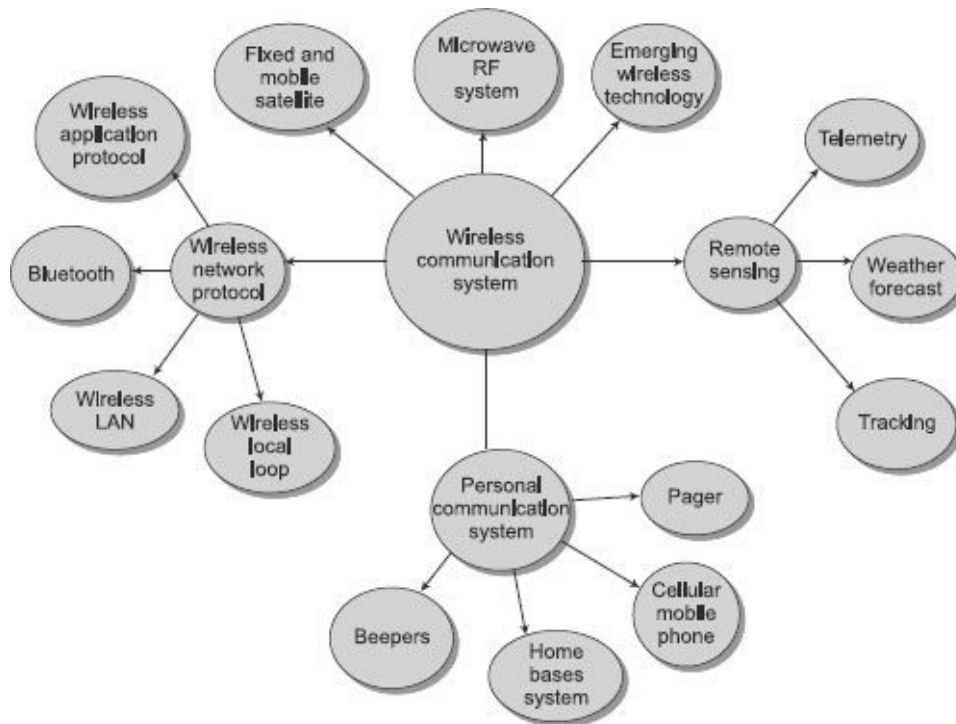

Figure 17.1 Different forms of RF based wireless communication systems

RF is similar to that of wireless and high-frequency signals. However, RF has frequencies ranging from a few kHz to roughly 1 GHz. This range extends to 300 GHz by considering microwave frequencies as radio frequency.

Many of the wireless devices make use of RF fields, for example satellite communications systems, cordless and cellular telephone, radio and television broadcast stations, all operate in the RF spectrum. Some wireless devices operate at IR or visible-light frequencies, whose electromagnetic wavelengths are shorter than those of RF fields.

Wireless communication can be defined as the transfer of information over a distance without the use of electrical conductors or wires. The distance for wireless communication may be small or large depending on the distance of communication. For example, a television remote control requires a shorter distance whereas radio communications requires a longer distance and may be thousands of kilometres long.

In wireless communication systems, wider bandwidths, larger signal dynamics and higher carrier frequencies are applied in order to fulfill the demand for higher data rates. Since the RF technology is, consequently, pushed to its operation boundaries, the intrinsic imperfections of the RF IC technology are more and more about governing the system performance of wireless modems. For RF based wireless communication, higher and even higher frequencies are always desired. This is due to the reason that higher frequencies include efficiency in propagation, immunity to some forms of noise and impairments as well as the size of the antenna required. The height of the antenna is determined on the basis of wavelength of the signal and is usually selected as one fourth of the wavelength of the signal.

During transmitting of the signal, there are always losses due to spreading of the RF energy as it propagates through free space. This space loss can be represented as

$$\begin{aligned} \text{Space loss in dB} &= 10 \log(P_t/P_r) \\ &= 20 \log(4\pi R/\lambda) \end{aligned} \tag{17.1}$$

where, P_t is the power of transmitter antenna,

P_r is the power of receiving antenna

R is the distance between two antennas.

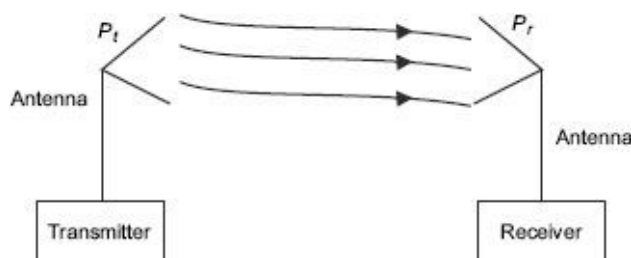

Figure 17.2 The simplified block diagram of the wireless communication system

The purpose of using of high frequencies in communication is to reduce the antenna size, increase efficiency in propagation and improve the signal-to-noise ratio. According to the following relation,

$$C = f\lambda \tag{17.2}$$

As frequency and wavelength are inversely proportional, we require high frequencies to reduce the antenna size.

17.2

RADIO FREQUENCY AND MICROWAVE SPECTRAL ANALYSIS

The display of electromagnetic radiation as a function of wavelength is termed as *electromagnetic spectrum*. Based upon the wavelengths, the spectrum is divided into various frequency bands as shown in [Figure 17.3](#).

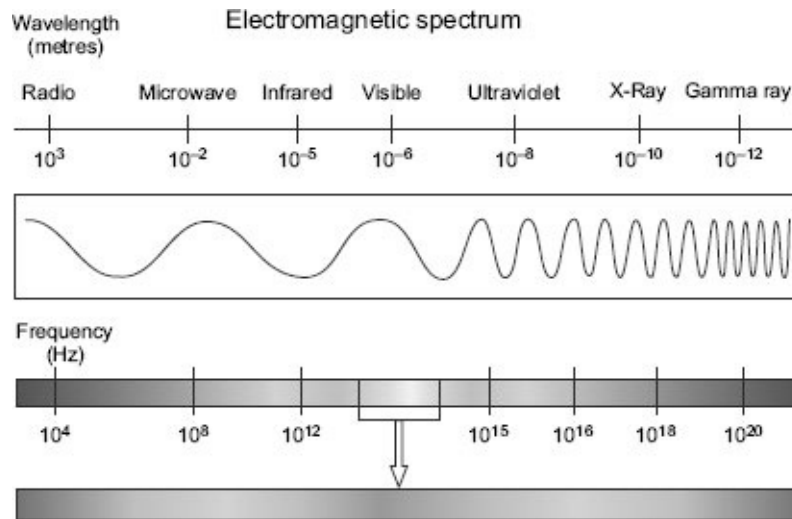

Figure 17.3 Different electromagnetic wave spectra

From [Figure 17.3](#), Radio Frequency (RF) are electromagnetic waves with wavelengths of 100 km to 1 mm, which is a frequency of 300 Hz to 3000 GHz. The microwave frequencies are electromagnetic waves with wavelengths ranging from as long as one metre to as short as one millimetre, or with frequencies between 300 MHz (0.3 GHz) and 300 GHz.

With the rapid advance of wireless technology and satellite sensor technology, there is a need for more and more accurate field measurements to complement overhead data in providing higher spectral resolution over progressively broader wavelength. In spectral analysis, the following factors are considered.

- Power in band
- Occupied bandwidth
- Adjacent channel power
- Resolution bandwidth
- Harmonic distortion
- Noise specification

17.2.1 Power in Band

It is the measurement of total power within any specified frequency range or band. Power in band is calculated by the following equation:

$$\text{Power in band} = \sum_{f_l}^{f_h} X(f)$$

where, X is the input power spectrum from a specified band, f_l is the low bound of the frequency band, and f_h is the high bound of the frequency band. The low and high bounds of this band can be determined from the centre frequency.

17.2.2 Occupied Bandwidth

It is the measurement of frequency band or bandwidth that contains a specified percentage of the total power of the signal. Occupied bandwidth is the inverse of power in band.

For example, if the specified percentage is 99 then the occupied bandwidth is the bandwidth that contains 99% of the total power of the signal. That is the frequency range

in between the vertical lines, as shown in [Figure 17.4](#).

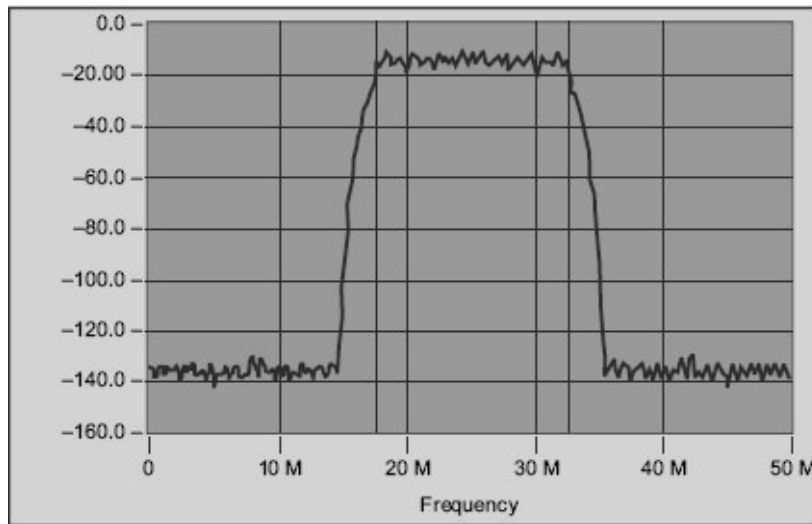

Figure 17.4 *Spectrum of an RF signal*

17.2.3 Adjacent Channel Power

It basically measures the way a particular channel and its two adjacent channels distribute power. This measurement is performed by calculating the total power in the channel and also the total power in the surrounding upper and lower channels.

17.2.4 Resolution Bandwidth

It is determined by the smallest frequency that can be resolved. In Fourier-transform-based spectrum analysers, the resolution bandwidth is inversely proportional to the number of samples acquired or the length of the window function. By taking more samples in the time domain or making the acquisition time longer, while keeping the sampling rate the same, the RBW will be lowered, meaning higher frequency resolution.

17.2.5 Harmonic Distortion

It is a measure of the amount of power contained in the harmonics of a fundamental signal. Harmonic distortion is inherent to devices and systems that possess nonlinear characteristics—the more nonlinear the device, the greater its harmonic distortion. When a signal of a particular frequency f_1 passes through a nonlinear system, the output of the system consists of f_1 and its harmonics f_2 and f_3 . [Figure 17.5](#) demonstrates this relationship.

Harmonic distortion is expressed as either power or as percentage ratio, where harmonic power distortion is P_{HD} , which is obtained from

$$P_{HD} = P_{fund} - P_{harm} \text{ (dB)} \quad (17.3)$$

where, P_{HD} is the power of the harmonic distortion in dBc, P_{fund} is the fundamental signal power in dB or dBm, and P_{harm} is the power of the harmonic of interest in dB or dBm.

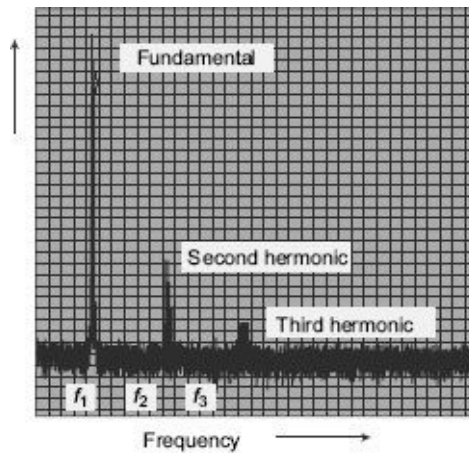

Figure 17.5 Fundamental frequency f_1 with second and third harmonics

To represent in the form of percentage ratio, it is converted into voltage, and calculated using the following equation.

$$\text{Percentage of distortion} = \frac{V_{\text{harm}}}{V_{\text{fund}}} \times 100\% \quad (17.4)$$

where V_{harm} and V_{fund} are the harmonic voltage and fundamental voltage respectively,

In some applications, the harmonic distortion is measured as a Total percentage Harmonic Distortion (THD). This measurement requires the power summation of all the harmonics in the spectrum band, as defined in the following equation:

$$\text{THD} = \sqrt{\frac{V_{h2}^2 + V_{h3}^2 + V_{h4}^2 + \dots + V_{hN}^2}{V_{\text{fund}}^2}} \times 100\% \quad (17.5)$$

17.2.6 Phase Noise

There are various sources of noise. When the carrier signal contain noise due to phase and frequency modulation of the signal then the noise is termed phase noise. The spectrum of phase noise is normally close to the carrier spectrum, and is measured in decibels relative to the carrier frequency (dBc).

Noise floor is a specified noise level below which signals cannot be detected, under a specific measurement conditions.

17.3

RADIO FREQUENCY SPECTRUM ANALYSER

Analysing signals in terms of their frequencies is called *spectrum analysis*. The spectrum analyser can measure the frequencies present in a complex signal or the frequencies resulting from modulation on a carrier.

The spectrum analyser is a measuring instrument that displays frequency components of a signal. Each frequency component contained in the input signal is displayed as a signal level corresponding to that frequency. The vertical scale displays the amplitude of each component, and the chosen frequency band is displayed horizontally.

Spectrum Analysers (SA) are useful as electronic test equipment used in design test and maintenance of radio-frequency circuitry and equipment. A spectrum analyser works

similar to that of an oscilloscope, as a basic tool used for observing signals. The only difference between the two is that where an oscilloscope looks at signals in the time domain, spectrum analyser looks at signals in the frequency domain.

A common spectrum analyser has the following features:

- Frequency tuning range—Measurement range of the analyser so that all of the frequency components of the signal can be measured.
- Frequency accuracy and stability—To be more stable and accurate than the signal to be measured.
- Sweep width—The frequency band over which the unit can sweep without readjustment.
- Resolution bandwidth—Need to be strong enough to resolve different spectral components of the signal.
- Sensitivity and/or noise figure—To observe very small signals or small parts of large signals.
- Sweep rate—Maximum sweep rate is established by the settling time of the filter that sets the resolution bandwidth.
- Dynamic range—The difference between the largest and smallest signal the analyser can measure without readjustment.
- Phase noise—A signal with spectral purity greater than that of the analyser conversion, oscillators cannot be characterised.

There are basically two types of spectrum analysers—analogue type and digital-type spectrum analysers:

- An analogue spectrum analyser—uses either a variable band-pass filter whose mid-frequency is automatically tuned (shifted, swept) through the range of frequencies of which the spectrum is to be measured or a super-heterodyne receiver where the local oscillator is swept through a range of frequencies.
- A digital spectrum analyser computes the Discrete Fourier Transform (DFT), a mathematical process that transforms a waveform into the components of its frequency spectrum.

Super-Heterodyne Analyser (SPA)

The working principle of a super-heterodyne type analyser is very similar to an AM or FM radio receiver. In SPA, the incoming RF signal is first moderately amplified with user-adjustable gain factor and then sent to the one input of a mixer which acts like an analogue multiplier. The output signal of a local oscillator as shown in [Figure 17.6](#), goes to other input of the mixer and then the output of the mixer is the sum and difference frequency between RF and local oscillator. This signal then goes to the Intermediate Frequency (IF) port of the mixer. This IF signal is subsequently band filtered, rectified and sent to the vertically deflecting plates of the Cathode Ray Tube (CRT) in the SPA. The functional block diagram of a simple Super-Heterodyne Analyser (SPA) is shown in [Figure 17.6](#).

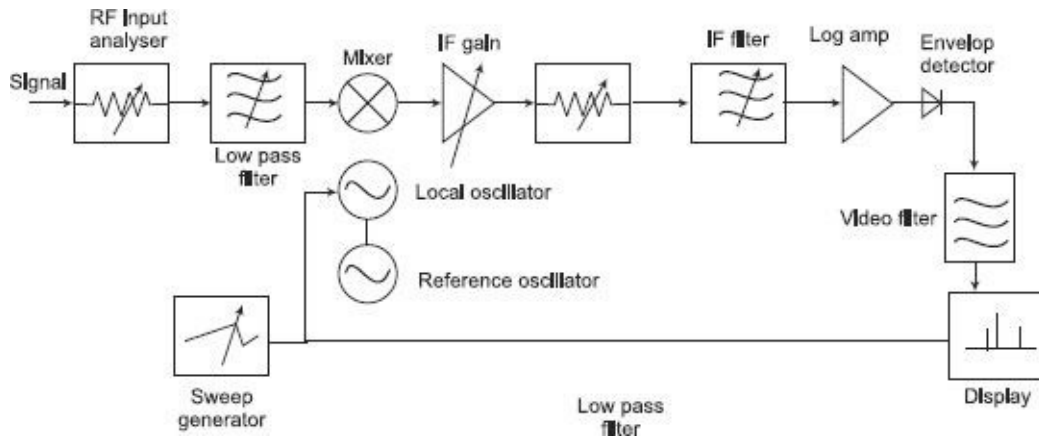

Figure 17.6 Functional block diagram of a simple super-heterodyne (SPA) analyser

17.4

RF SCALAR AND VECTOR NETWORK ANALYSER

The RF network analyser is an active test instrument which generates a signal that is applied to the device under test, and then it measures the response.

The different functional elements of a common RF network analyzer are the following:

(a) Signal Separation The signal separation element is often called test set. It provides two functions:

- Measure a portion of incident signal for rationing. This may be accomplished using a splitter or directional coupler.
- Separate the incident (forward) and reflected (reverse) travelling waves at the input of DUT.

(b) Receiver and Signal Detection When the signal is passed through the device under test and separated from the source signal, it is processed in the RF network analyser so that the results can be gained. The first stage consists of a radio receiver with a demodulator or detector. Typically, a tuned radio receiver is used to provide the best sensitivity, dynamic range as well as harmonic/spurious signal rejection.

(c) Processor and Display The processed RF signals from the receiver and detector section are displayed in a format that can be interpreted.

17.4.1 Different Types of RF Analysers

There are different types of network analysers which are able to measure the parameters of the RF components and devices in different ways. Based on this network, analysers can be classified as

1. Scalar network analyser
2. Vector network analyser

1. Scalar Network Analyser (SNA)

The Scalar Network Analyser (SNA) is used to measure frequency response of any device or a system. It basically consists of two components: (i) sweep generator, and (ii) spectrum generator. The *sweep generator* generates constant amplitude sinusoid with varying

frequency starting from low to high. The minimum (low) and maximum (high) value of the frequency and the time to increase from minimum to maximum frequency are user-configurable. The spectrum analyser plots the frequency contents of the input signal. Now, if the output of the sweep generator is connected to the input of the spectrum analyser then the spectrum analyser will show a constant horizontal line on the screen. As the amplitude of all the harmonics of the sweep generator output signal are same, the line will shift vertically if the amplitude of the sweep generator output signal is increased. Now if a device under test whose frequency responses are to be obtained is placed in between the sweep generator and spectrum analyser, meaning output of sweep generator is connected to the input of the device and output of the device is connected to the input of the spectrum analyser, the spectrum analyser will directly display the frequency response of the device. The straight line cannot be seen on the spectrum analyser screen if the response of the device changes the sweep generator output according to the frequency and the response of the device at that frequency.

2. Vector Network Analyser (VNA)

A Vector Network Analyser (VNA) works in similar fashion as the scalar network analyser, the difference being that it can measure amplitude as well as phase of an RF signal. That is why it is called VNA. The sweep frequency range can be adjusted by the user. The VNA measures the frequency response of the device under test over the adjusted range of sweep frequency. First, the VNA is used to measure the incident test signal from the sweep generator (which is a constant line on the screen), then the reflected signal from the test device, by using directional coupler as shown in [Figure 17.7](#), and after that the transmitted signal from the RF device under test. Then the VNA automatically reverses the connections to measure the same quantities looking into the device from the opposite direction. After completion of the process, the VNA displays these measured quantities as a function of frequency.

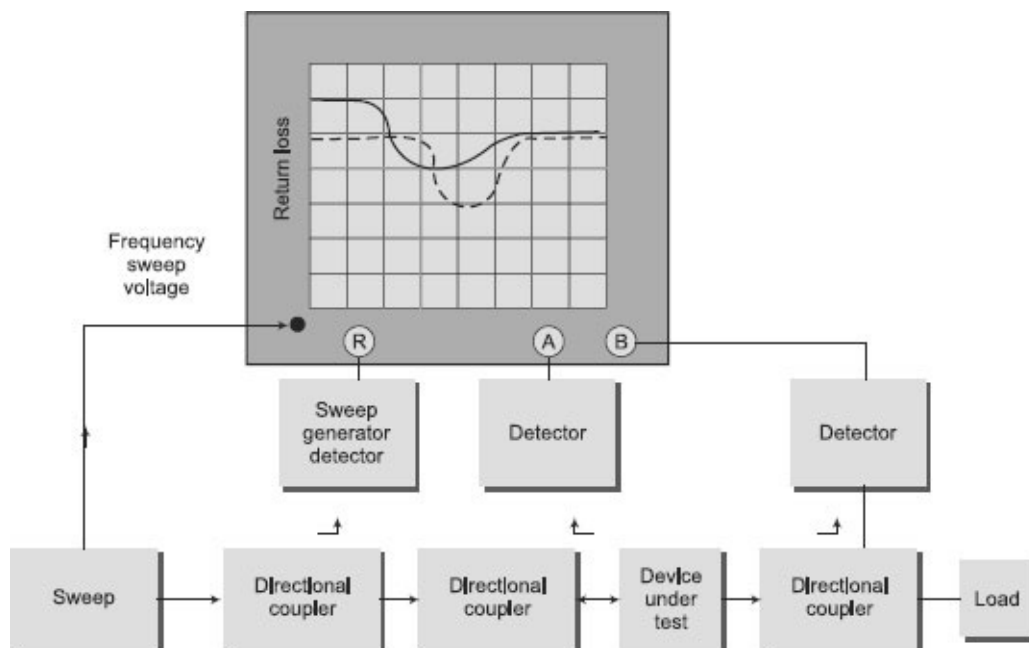

Figure 17.7 Functional block diagram of a Vector Network Analyser (VNA)

The VNA is a common device required for RF design applications. The device is often used to characterise RF device performance in terms of network scattering parameters, or S parameters.

Modulation is defined as the process in which some characteristic parameters of a high-frequency signal is varied according to the message signal. The lower frequency signal is called the *modulating signal*, the higher frequency signal is called the *carrier*, and the output signal is called the *modulated signal*.

According to the modulation process, modulation is of two types—analogue modulation and digital modulation, discussed in the following subsections

17.5.1 Analog Modulation

In analog modulation, characteristic parameters of a high-frequency sinusoidal signal (called carrier signal) is varied according to the message signal, called analog modulation. Generally, the carrier is represented as

$$A_c \cos (2\pi f_c t + \varphi) \quad (17.6)$$

where A_c is the amplitude, f_c is the frequency and φ is the phase.

The three characteristic parameters of the carrier signal are amplitude, phase and frequency, and these can be varied according to the message signal. So, analog modulation techniques are classified into three types. They are

- Amplitude modulation
- Phase modulation
- Frequency modulation

1. Amplitude Modulation (AM)

Amplitude modulation means modulating the amplitude of the given signal. In amplitude modulation, the amplitude of the carrier signal is varied in accordance to the instantaneous amplitude of the modulating signal. The complex envelop of an AM signal is given by

$$s(t) = A[1 + m(t)] \quad (17.7)$$

where, the constant A has been included to specify the power level and $m(t)$ is the modulating signal (may be analog or digital). This equation reduces to the following for AM signal:

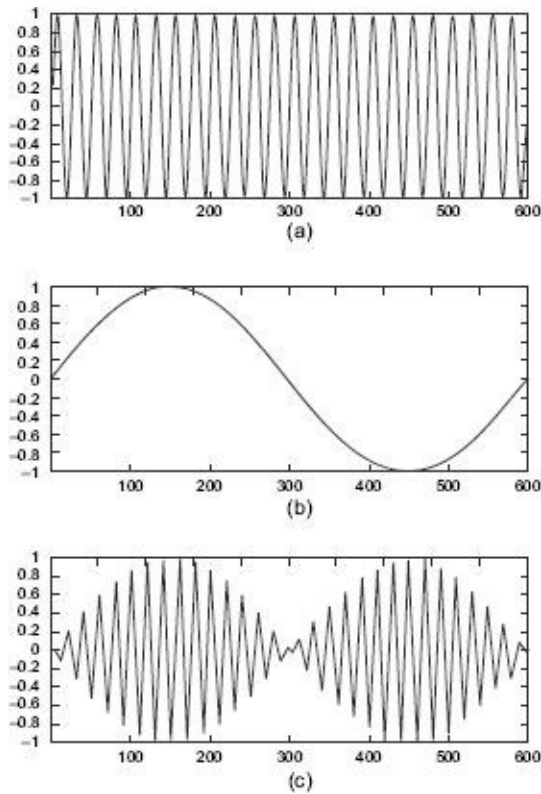

Figure 17.8 (a) Original message signal (b) modulating signal and (c) the signal after AM

$$s(t) = A[1 + m(t)]\cos(2f_c t) \quad (17.8)$$

Figure 17.8 shows the modulating signal and the signal after AM.

2. Phase Modulation (PM)

The phase modulation is defined as a process in which the phase of the carrier is varied linearly according to the message signal. If $m(t)$ is the message signal (or the modulation signal) to be transmitted with the help of a carrier signal of amplitude a_c , frequency ω_c and phase angle ϕ_c , then the time domain equation of the phase modulated signal will become

$$S(t) = A_c \sin(\omega_c t + m(t) + \phi_c) \quad (17.9)$$

and the message signal, carrier signal and modulated signal are shown in Figure 17.9.

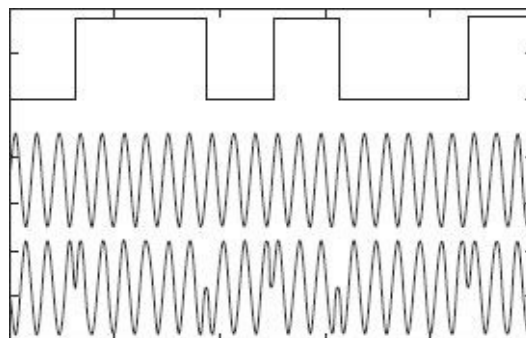

Figure 17.9 Message signal, carrier signal and modulated signal

3. Frequency Modulation (FM)

Frequency modulation means modulating the frequency of the signal, by change in carrier frequency. Frequency of carrier signal is varied by the amplitude of message signal. Frequency modulation has many attractive improvements over amplitude modulation. It offers the advantage of almost total immunity from noise interference as it eliminates the

problem of fading, which is pronounced in amplitude modulation.

$$s(t) = A_C \cos \left(2\pi f_C t + 2\pi k \int_0^t m(t) dt \right) \quad (17.10)$$

Information signal = $m(t)$

Carrier signal = $A_C \cos(2\pi f_C t)$

k is the frequency deviation constant (Hz/volt) that represents the maximum shift of signal frequency from the carrier frequency in one direction

Figure 17.10 shows the time domain frequency modulated signal. The figure demonstrates how a message signal modifies the frequency of a carrier signal in FM.

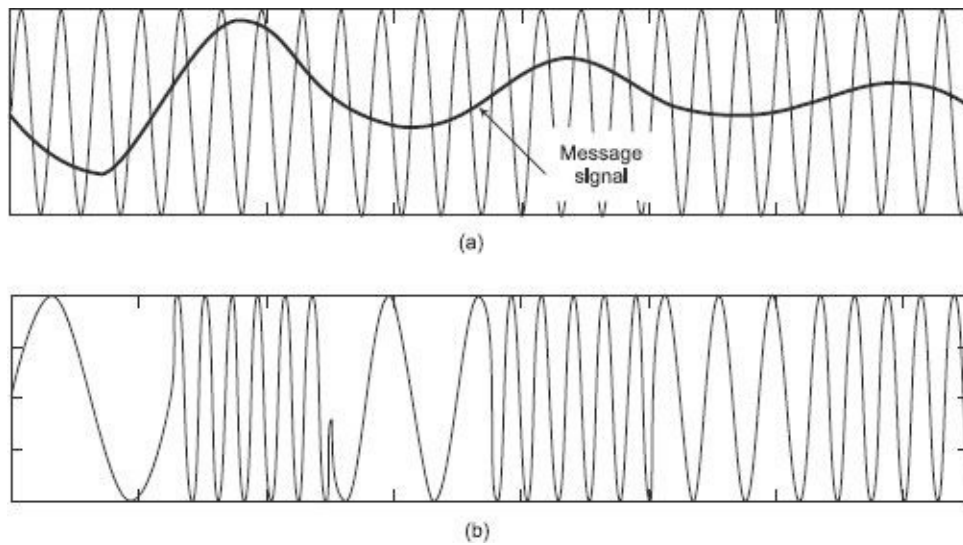

AM modulation requires less bandwidth when compared to FM modulation. But FM modulation requires less power when compared to AM modulation.

Figure 17.10 Carrier wave with message signal, (b) Frequency modulated signal

17.5.2 Digital Modulation

The digital-modulation process involves switching or keying the amplitude, frequency or phase of the carrier according to the incoming data. The input to the digital modulators is in binary digits based upon the keying these techniques are divided into three types:

1. Amplitude Shift Keying (ASK)
2. Frequency Shift Keying (FSK)
3. Phase Shift Keying (PSK)

By digital modulation, we can convey a large amount of information as compared to analog modulation and they also provide more information capacity, compatibility with digital data services, higher data security, better quality communications, and quicker system availability.

1. Amplitude Shift Keying (ASK)

In ASK, the amplitude of the carrier is changed according to the modulating waveform which is a digital signal (bit). The level of amplitude can be used to represent binary logic 0s and 1s. Here, two states of the carrier signal is considered, i.e. ON or OFF. In the modulated signal, logic 0 is represented by the absence of a carrier, thus it is said to be an

OFF/ON keying operation. ASK demonstrates poor performance, as it is heavily affected by noise and interference. Mathematically it can be represented as;

$$S(t) = \begin{cases} A_c \cos(2\pi f_c t) & \text{for bit 1} \\ 0 & \text{for bit 0} \end{cases} \quad (17.11)$$

Figure 17.11 ASK modulated signal

2. Frequency Shift Keying (FSK)

In FSK, the frequency of the carrier is changed according to the modulating waveform which is a digital signal. The simplest FSK is binary FSK (BFSK). BFSK literally implies using a couple of discrete frequencies to transmit binary (0s and 1s) information. With this scheme, the “1” is called the *mark frequency* and the “0” is called the *space frequency*. Mathematically it can be represented as;

$$S(t) = \begin{cases} A_c \cos(2\pi f_1 t) & \text{for bit 1} \\ A_c \cos(2\pi f_2 t) & \text{for bit 0} \end{cases} \quad (17.12)$$

Early telephone-line modems used audio frequency-shift keying to send and receive data, up to rates of about 300 bits per second. Figure 17.12 shows the FSK message signal, carrier signal and modulated signal

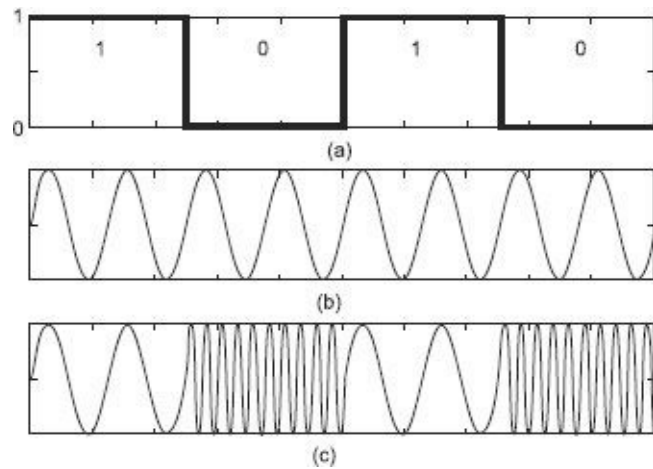

Figure 17.12 (a) Message signal (b) carrier signal (c) FSK modulated signal

3. Phase Shift Keying (PSK)

In PSK, the phase of the carrier is changed according to the modulating waveform which is a digital signal. PSK uses a finite number of phases; each assigned a unique pattern of binary bits. Usually, each phase encodes an equal number of bits. Each pattern of bits forms the symbol that is represented by the particular phase.

Mathematically it can be represented as;

$$s_0(t) = \sqrt{\frac{2E_b}{T_b}} \cos(2\pi f_c t + \pi) = -\sqrt{\frac{2E_b}{T_b}} \cos(2\pi f_c t) \quad \text{for binary "0"}$$

$$S_0(t) = \sqrt{\frac{2E_b}{T_b}} \cos(2\pi f_c t) \quad \text{for binary "1"} \quad (17.13)$$

where f_c is the frequency of the carrier wave, and E_b and T_b are energy per bit and bit duration respectively.. Figure 17. 13 shows the message signal and PSK modulated signal

- PSK has better power and frequency efficiencies compared to ASK and FSK.
- PSK achieves small Bit Error Rate (BER) for the same C/N (carrier-noise ratio).
- PSK has constant envelope, and is robust to time-varying fading channel.
- PSK is popularly used in many communication systems such as satellite and mobile communication systems.

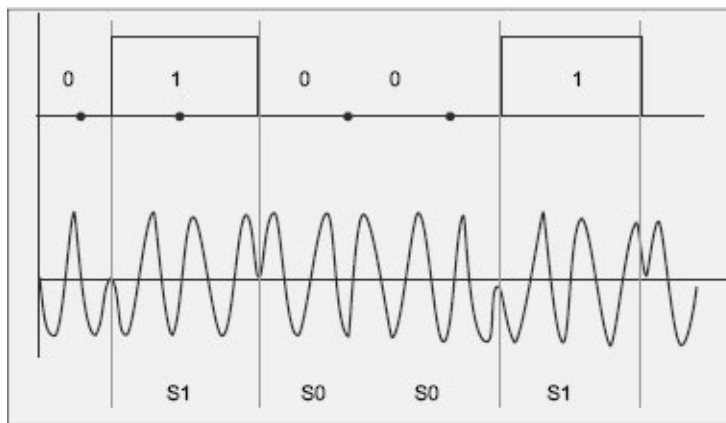

Figure 17.13 Message signal and PSK modulated signal

17.5.3 Modulation Measurement

Two different types of modulation measurements are developed in order to take into account both the amplitude, and phase noise on the carrier. They are Modulation Error Ratio (MER) and Error Vector Magnitude (EVM). Error vector magnitude and modulation error ratio express same kind of information and are closely related to each other. In other words, we can say that there is a one-to-one relationship between the two types of measurements.

In a digital system, Modulation Error Ratio (MER) is similar to Signal-to-Noise or Carrier-to-Noise used in analog systems. As compared to EVM, MER is easier to understand as it relates directly to the S/N (signal to noise). The amount of the margin the system has before failure can be determined by determining the MER (modulation error ratio) of a digital signal. At the time of system failure, MER is more advantageous as compared to analog systems as poor MER is not noticeable on the picture right up. On the other hand, in analog systems degradations in carrier to noise performance can be seen.

In analog systems, carrier-to-noise ratio is simply a measure of the ratio of peak video carrier power over the noise in the channel, over the system bandwidth expressed in dB. For this type of measurement, we can also use digital channels, but unfortunately they do not provide the complete picture and due to this reason, we have to go for MER and EVM.

MER and EVM can be directly correlated with each other since they are essentially the same measurement; the only difference is on specification and performance. MER and EVM can be considered a figure of merit for the QAM signal that includes all types of impairments, not just noise as in carrier-to-noise in analog systems.

Figure 17.14 shows the ideal and measured location, where, v is the ideal symbol vector, w is the measured symbol vector, q is the phase error, ($e = w - v$) is the magnitude

error vector, and e/v is the EVM.

This quantifies, but does not necessarily reveal, the nature of the impairment. To remove the dependence on system gain distribution, EVM is normalized by $|v|$, which is expressed as a percentage. Analytically, rms value of EVM over a measurement window of N symbols is defined as

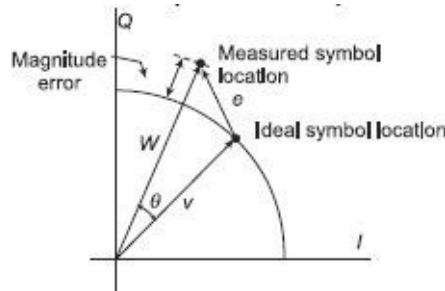

Figure 17.14 Ideal and measured location

$$\text{EVM} = \frac{\sqrt{\frac{1}{N} \sum_{j=1}^N [(I_j - \bar{I}_j)^2 + (Q_j - \bar{Q}_j)^2]}}{|v_{\max}|} \tag{17.14}$$

MER is defined as follows:

MER = 10 log (rms error magnitude / average symbol magnitude) measured in dB

17.6

COMMUNICATION SYSTEMS

Communication is the process of transferring information from one place to another. The information generated at source is transferred to the receiver through communication channel.

The basic electronic communication system can be shown in Figure 17.15 as follows;

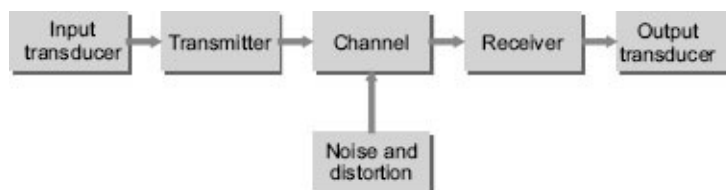

Figure 17.15 Block diagram of a basic communication system

On the source side, there is a transmitter device that makes the input electrical information suitable for efficient transmission over a given channel. In general, a transmitter modulates amplitude or frequency of a high-frequency carrier wave by an original electrical information signal which is known as the *baseband signal*. On the destination side, the receiver is the device that receives information from the channel and demodulates the electrical signal from it. The receiver also amplifies and removes noise and distortion from the noise contaminated received signal. The output transducer converts electrical signal from the receiver output to a form of message as required by the user. Communication can be made in two forms—*analog communication* and *digital communication*.

RF Communication System Components

The RF communication system consists of various components and each performs different functions as listed below:

- PLO: Generates the RF carrier at the required frequency
- Modulator: Varies the frequency, amplitude, or phase of an IF carrier to put information onto it
- Upconverter: Shifts the modulated IF signal to RF signal
- Power amplifier: Increases the power level of the modulated RF carrier
- TX antenna: Transmits the RF carrier in the direction of the receiver
- RX antenna: Collects the transmitted RF signal at the receiver
- RF filter: Allows only a specified range of RF frequencies to pass and blocks all other frequencies
- LNA: Amplifies the weak received RF carrier
- Mixer and IF amplifier: Shifts the RF carrier to a lower frequency below the RF band and amplifies it to a level where it can be demodulated
- Demodulator: Removes the information from the low-frequency carrier

An RF communication system block diagram is shown in [Figure 17.16](#).

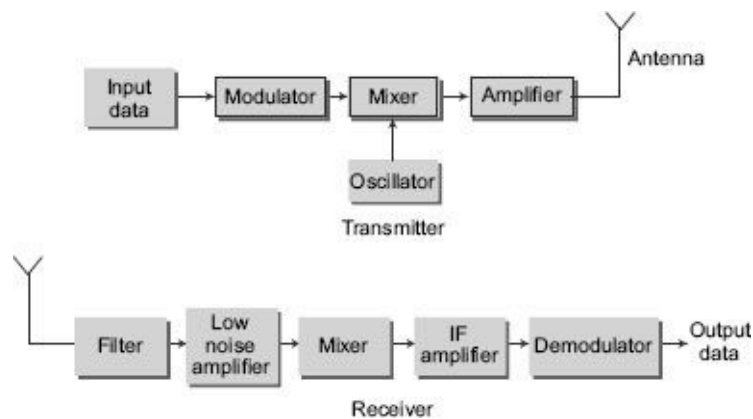

Figure 17.16 RF communication system

It applies to any type of wireless RF communication system: cellular phone, wireless LAN, satellite communications system. Any RF communication system must contain all of the devices shown though performance requirements of each device vary from system to system.

17.7

RF VOLTAGE AND POWER MEASUREMENT

A system's output power level is frequently the critical factor in the design, and ultimately the performance of almost all radio frequency and microwave equipment. Measurement uncertainties cause ambiguities in realisable performance of a transmitter.

For the measurement of average power, a sensor along with a calibrated power metre is connected with the RF transmitter. Initially, if the output of the sensor is switched off/not allowed to enter into the power metre, the pointer of the power meter is set to zero. Then the sensor is switched on and the indication on the power meter is observed, which

indicates the average power of the transmitter.

For design and application of an RF and microwave system, it is necessary to determine the power. Average power is very popular and used in specifying almost all RF and microwave systems. It is necessary to determine power level. Generally, there are three methods for measuring power at RF and microwave frequencies. Each of these methods uses different kinds of devices to convert RF power to measurable dc or low frequency signal. The methods are as follows:

1. By using a thermistor
2. By using a thermocouple
3. By using a diode detector

17.7.1 Power Measurement Using a Thermistor

From early times, for the measurement of RF/microwave power, bolometer sensors, especially thermistors, are being used. Presently, thermocouple and diode technologies have captured the bulk of those applications because of their increased sensitivities, wider dynamic ranges and higher power capabilities. For certain applications, a thermistor is still the sensor of choice due to its power substitution capability.

The *bolometer* is a temperature—sensitive resistive element, whose resistance varies due to change in temperature. The change in temperature results from converting RF or microwave energy into heat within the bolometric element. Basically, two types of bolometers are used—one is the barretter and the other is the thermistor. A *barretter* is a thin wire that has a positive temperature coefficient of resistance, which is not commonly used now. *Thermistors* are semiconductors with negative temperature coefficient.

17.7.2 Power Measurement Using a Thermocouple

Thermocouples work on the principle based on dissimilar metals generating a voltage due to temperature differences at hot and a cold junction of the two metals.

The two main reasons for evolution of thermocouples are

1. They exhibit higher sensitivity than previous thermistor technology
2. They feature an inherent square-law detection characteristic (input RF power is proportional to dc voltage out).

Since thermocouples are heat-based sensors, they are true “averaging detectors.” This recommends them for all types of signal formats from CW to complex digital-phase modulations. They are more rugged than thermistors, make useable power measurements down to 0.3 mW (−30 dBm, full scale), and have lower measurement uncertainty because of better SWR.

17.7.3 Power Measurement Using a Diode Detector

Diodes convert high-frequency energy to dc by way of their rectification properties, which arise from their nonlinear current-voltage (*I-V*) characteristic.

Rectifying diodes have been used as detectors and for relative power measurements at microwave frequencies. For absolute power measurement, however, diode technology had been limited mainly to RF and low microwave frequencies.

17.7.4 Measuring RF Voltages with a Voltmeter

To measure RF voltages ranging from few hundred millivolts to several hundred millivolts, a voltmeter uses diode detectors. Generally diode detectors follow inverse square law below 100V. So by taking the advantage of inverse square law, power detectors or voltage detectors are designed.

To achieve best sensitivity, a diode should be matched as closely as possible to source impedance. Simple diode detectors are used for designing RF voltmeter to measure voltages from 100 mV to several hundred mV. In the design of voltmeter, two types of diode detectors are used.

1. Series detector
2. Shunt detector

Out of these, shunt detectors are mostly suitable for measuring RF and microwave voltages. In this case, diodes are directly connected to ground as shown in [Figure 17.17](#).

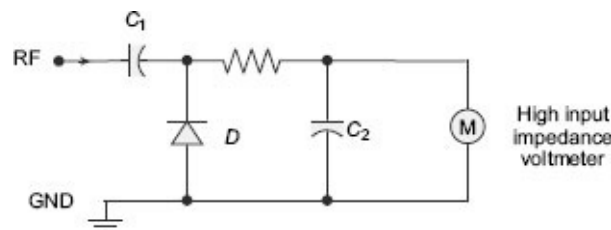

Figure 17.17 Circuit diagram of a shunt type detector

In [Figure 17.17](#) (shunt detector), the diode is connected in shunt and it is grounded. The design components should have short leads to avoid any error readings and a termination resistor is connected across the input to measure output of amplifier and signal sources. A small silicon diode is readily available but germanium diodes will give low offset voltages. In order to remove these offset voltages, a battery and resistor (high value) is connected in the circuit.

EXERCISE

Objective-type Questions

1. The bandwidth of RF including microwave is approximately
 - (a) 20 Hz to 20 kHz
 - (b) 1 kHz to 300 GHz
 - (c) 3 GHz to 3000 GHz
 - (d) 3 Hz to 300 MHz
2. Identify the wrong statement.
 - (a) Power in band is the measure of total power within a specified frequency range.
 - (b) Occupied bandwidth measures bandwidth that contains total power of the signal.
 - (c) Adjacent channel power measures the way a particular channel and its two adjacent channels distribute power.
 - (d) Resolution bandwidth measures the smallest frequency that can be resolved.
3. In Fourier transform-based spectrum analysers, the resolution bandwidth is

- (a) proportion to the length of window function
 - (b) inversely proportional to the sampling frequency
 - (c) inversely proportional to the length of the window function
 - (d) proportional to the sampling frequency
4. Phase noises are due to
- (a) modulation of the signal with carrier signal
 - (b) noise from other signals
 - (c) noise due to change of phase during reflection
 - (d) noise due to change of phase during transmission in different medium
5. In the sweep generator, if the output is connected to the input of a spectrum analyser then
- (a) a single vertical can be observed
 - (b) a single horizontal line can be observed
 - (c) a sawtooth wave can be observed
 - (d) lot of random lines can be observed
6. Identify the correct statement.
- (a) Carrier frequencies of FM signals are relatively lower than AM signals.
 - (b) Antennas for FM signals are larger in size than AM antennas.
 - (c) FM signals can travel longer distance than AM signals
 - (d) FM signals are more immune to noise than AM signals
7. This is not a digital modulation technique:
- (a) Amplitude shift keying
 - (b) Phase shift keying
 - (c) Frequency shift keying
 - (d) Pulse shift keying
8. The sensor used for RF power measurement
- (a) Thermocouple
 - (b) Microphone
 - (c) Strain gauge
 - (d) Photodiode

Answers						
1. (b)	2. (b)	3. (c)	4. (d)	5. (b)	6. (d)	7.(d)
8. (a)						

Short-answer Questions

1. Why is spectral analysis important in RF communication system? What are the main different factors being measured? Define each factor.
2. How are the power in band and occupiedband width interrelated? Explain in brief. How is the adjacent channel power measured?
3. How is the harmonic distortion calculated? State the possible sources of phase noise.
4. What are different features a typical spectrum analyser must have? What are the different types of spectrum analyser being used?
5. State the working principle of a super-heterodyne-type spectrum analyser.
6. How does a vector network analyser work? Write down some of its applications

7. What are the different analog-modulation techniques used in communication? Compare each of them with one another.
8. What are the different digital-modulation techniques used in communication? Compare each of them with one another.
9. How can a diode be used for measurement of RF power? Compare the bolometer with thermocouple based RF power. metre
10. Explain the RF voltage measurement techniques with a proper circuit diagram.

18.1

INTRODUCTION

Kaol first suggested the possibility that low-loss optical fibres could be competitive with coaxial cable and metal waveguides for telecommunications applications. It was not, however, until 1970 when Corning Glass Works announced an optical fibre with loss less than the benchmark level of 10 dB/km. After that, commercial applications began to be realised. The revolutionary concept which Corning incorporated and which eventually drove the rapid development of optical fibre communications was primarily a materials one—it was the realisation that low doping levels and very small index changes could successfully guide light for tens of kilometres before reaching the detection limit. The ensuing demand for optical fibres in engineering and research applications spurred further applications. Today, we see a tremendous variety of commercial and laboratory applications of optical fibre technology.

18.2

HOW DOES AN OPTICAL FIBRE WORK?

The optical fibre works on principles similar to other waveguides, with the important inclusion of a cylindrical axis of symmetry.

When light is travelling from one medium (n_0) into a medium of different density (n_1), a certain amount of incident light is reflected. This effect is more prominent where the light is travelling from a high-density medium into a lower-density medium. The exact amount of light that is reflected depends on the degree of change of refractive index and on the angle of incidence. If the angle of incidence is increased, the angle of refraction is increased at a greater rate. At a certain incident angle (q_C), the refracted ray will have an angle of refraction that has reached 90° (that is, the refracted ray emerges parallel to the interface). This is referred to as the *critical angle*. For rays that have incident angles greater than the critical angle, the ray is internally reflected totally. In theory, total internal reflection is considered to reflect 100% of the light energy but in practice, it reflects about 99.9% of the incident ray.

$$\theta_c = \sin^{-1}\left(\frac{n_1}{n_0}\right) \quad (18.1)$$

Figure 18.1 shows the generic optical fibre design, with a core of high refractive index surrounded by a low-index cladding. This index difference requires that light from inside the fibre which is incident at an angle greater than the critical angle be totally internally reflected at the interface.

A simple geometrical picture appears to allow a continuous range of internally reflected rays inside the structure; in fact, the light (being a wave) must satisfy a self-interference condition in order to be trapped in the waveguide. There are only a finite number of paths which satisfy this condition; these are analogous to the propagating electromagnetic modes of the structure. Fibres which support a large number of modes (these are fibres of large core and large numerical aperture) are called *multimode fibres*, whereas a fibres allowing only one mode of propagation are called single-mode fibres.

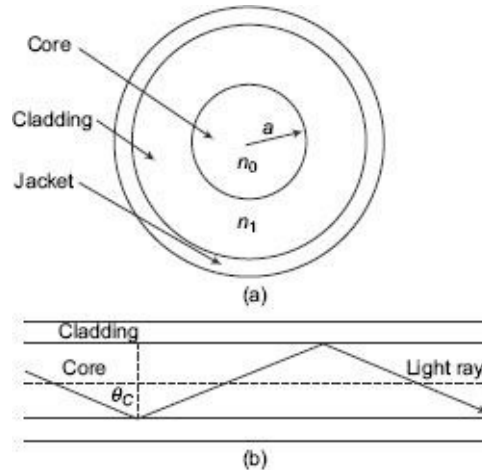

Figure 18.1 (a) Generic optical fibre design (cross-section view) (b) Path of a ray propagating at the geometric angle for total internal reflection

18.3

SOURCES AND DETECTORS

This section will examine the operation of the optical sources and their associated detectors used with fibre optic systems.

18.3.1 Optical Sources

Effective optical sources for fibre optic systems need the following features:

- To be able to effectively couple light into small fibre core, as small as 8.5 micrometres for single-mode fibres
- Easily modulated by electrical signals to convey data, with good linearity to prevent harmonics and inter-modulation distortion
- Provide high optical output power
- Have high reliability
- Small size and weight
- Low cost

Light emitting junction diodes (LED) and laser diodes (LD) fulfill many of these requirements and we will now examine their properties in detail.

1. Light Emitting Diodes (LEDs)

LED is basically a specially designed *p-n* junction diode. LEDs can provide light output in the visible spectrum as well as in the 850 nm, 1350 nm and the 1500 nm windows. Compared with the laser, the LED has a lower output power, slower switching speed and

greater spectral width, hence there is more dispersion. These deficiencies make it inferior for use with high-speed data links and telecommunications. However, it is widely used for short- and medium-range systems using both glass and plastic fibres because it is simple, cheap, reliable and is less temperature dependent. It is also unaffected by incoming light energy from Fresnel reflections, etc. Although the lower power makes it safer to use, it can still be dangerous when the light is concentrated through a viewing instrument. Typical LED is shown in wires [Figure 18.2](#).

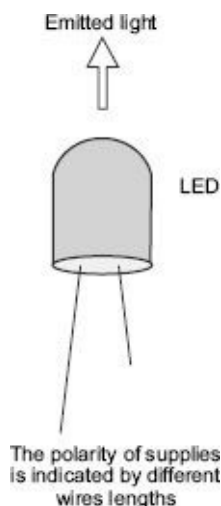

Figure 18.2 Light Emitting Diode (LED)

Basic LED Operating Principles

When a positive voltage is applied to the *p*-region and a negative voltage applied to the *n*-region, electrons and holes flow towards the junction of the two regions where they combine. When an electron combines with a hole, the atom returns to its neutral state and energy is released, having been converted into optical energy in the form of photons. In its simplest form, the radiated energy from the LED is caused by the recombination of the electrons and holes, which are injected into the junction by the forward bias voltage.

[Figure 18.3](#) illustrates this process.

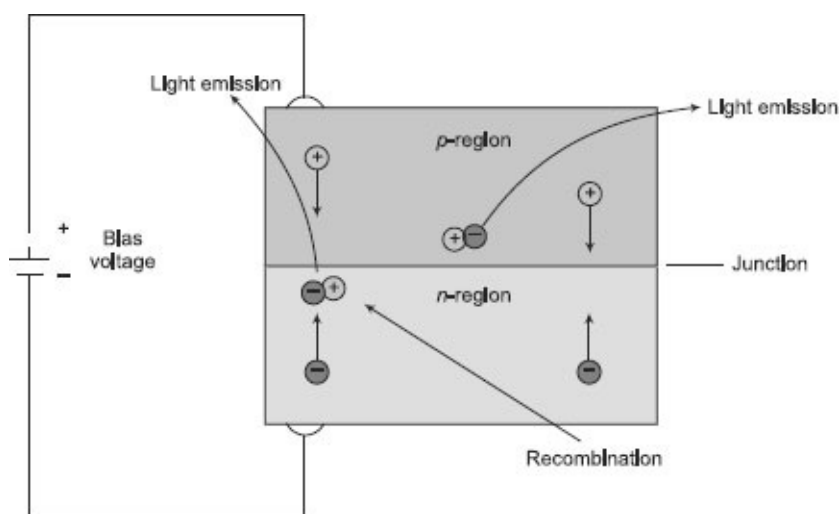

Figure 18.3 Basic LED Operation

The size of the band gap determines the energy of the emitted photon. Different semiconductor materials have different band-gap energies and the gap energy (*W*) in electronvolts (eV) can be related to the wavelength (*l*) by the equation:

$$\lambda = 1240/W \text{ nanometer} \tag{18.2}$$

The usual LEDs applied in fibre optic systems use gallium aluminum arsenide (GaAlAs) for 800 to 900 nm wavelengths and gallium arsenide (GaAs) for 930 nm. LEDs for use with plastic fibres need to operate at about 660 nm and are produced with gallium arsenide phosphide (GaAsP) compounds. Various indium gallium arsenide phosphide (InGaAsP) compounds are used for longer wavelengths of 1300 and 1550 nm.

2. Lasers

Another form of LED is the laser diode. The most common form of laser diode is called an Injection Laser Diode (ILD) or just Injection Diode (ID). The word *injection* is not of interest—it merely refers to part of the process occurring inside the semiconductor material. A laser provides a light of fixed wavelength which can be in the visible region around 635 nm or in any one of the three infrared windows. The light has a very narrow bandwidth, typically only a few nanometres wide. This ensures that chromatic dispersion is kept to a low value and this, together with fast switching, allows high data-transmission rates. As the laser device itself is barely visible to the unaided eye, it must be contained in some form of package. Two typical examples are shown in Figure 18.4.

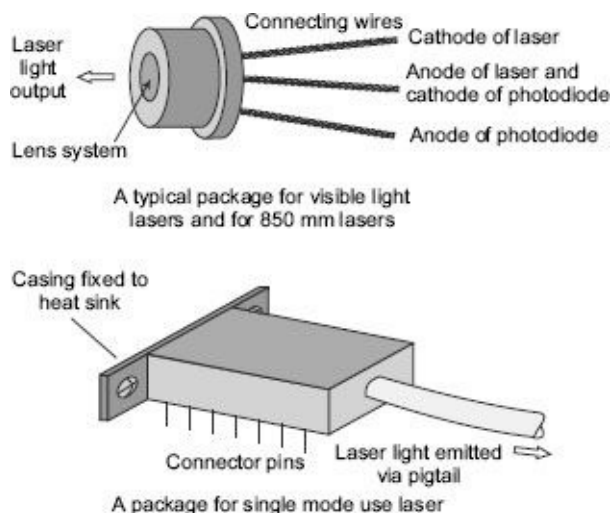

Figure 18.4 Typical laser diode

Basic Principles of Laser Operation LASER stands for Light Amplification by the Stimulated Emission of Radiation. LEDs and lasers use very similar principles of operation. In the earlier section of LED, it has been discussed that light is emitted from an LED when an electron drops from a high energy level to a lower one. When this occurs without outside influence, it is known as *spontaneous emission*. This occurs in some radioactive material. With the LED discussed in the previous section, a forward-bias voltage was used to stimulate the emission. An electron sitting at the upper energy level can also be stimulated to drop to the lower level by a photon with the right amount of energy. In this way, the external photon can stimulate the emission of a second photon at the same wavelength. Laser action takes place through optical resonance. The laser structure is very similar to an edge LED, having a thin, narrow active region with the addition of reflective-end facets and reflective sides as shown in Figure 18.5. In this resonator, the light is confined and reflected backward and forward through the excited medium. The laser is biased to begin the emission of photons. The photons reflect backward and forward and stimulate further emission of photons from electrons waiting to recombine. The light travelling back and forth along the axis of the resonator continues this action and builds up in strength until it is strong enough to break through the

reflective end and thus, a laser beam is formed.

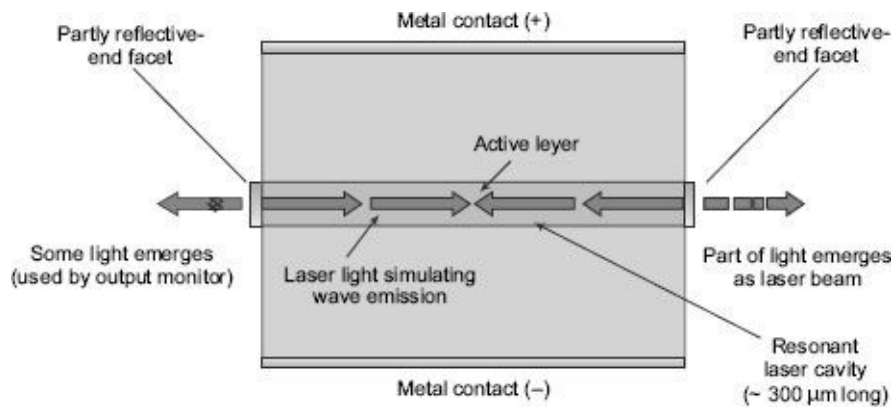

Figure 18.5 LASER source

18.3.2 Optical Detectors

The function of the optical detector is to efficiently convert the small amount of light energy received from the fibre, as photons, into electrical signals. The detector needs to be a low inherent noise device, incorporating appropriate amplification to generate useful output signals from low level inputs. Two main types of devices are used for practical detectors: PIN diodes and avalanche photodiodes.

1. PIN Diodes

The PIN diode is very widely used as a detector for converting light energy received from the optical fibre into an electronic signal. The PIN diodes look like LEDs. The difference is in its construction. The name 'PIN' stands as 'P' for *p*-type semiconductor, 'I' for intrinsic semiconductor and 'N' stands for *n*-type semiconductor. In this case, the intrinsic layer is in the middle position and one side covers the *p*-type semiconductor whereas the other side covers the *n*-type semiconductor. Hence, it is called P-I-N or PIN diode.

The Theory of its Operation The PIN photodiode has a wide intrinsic semiconductor layer separating the *p*- and *n*-regions, as shown in Figure 18.6. The diode is reverse biased (4.5–18 volts) and this helps draw the current carriers away from the intrinsic region. The width of the intrinsic layer ensures that there is a high probability of incoming photons being absorbed in it rather than in the *p*- or *n*-regions. The intrinsic layer has a high resistance because it has no free charges. This results in most of the diode voltage appearing across it, and the resultant electrical field raises the response speed and reduces noise. When light of suitable energy strikes the intrinsic layer, it creates electron-hole pairs by raising an electron from the valence band to the conduction band and leaving a hole behind in the process. The bias voltage causes these current carriers (electrons in the conduction band) to quickly drift away from the junction region, producing a current proportional to the incident light, as shown in Figure 18.6.

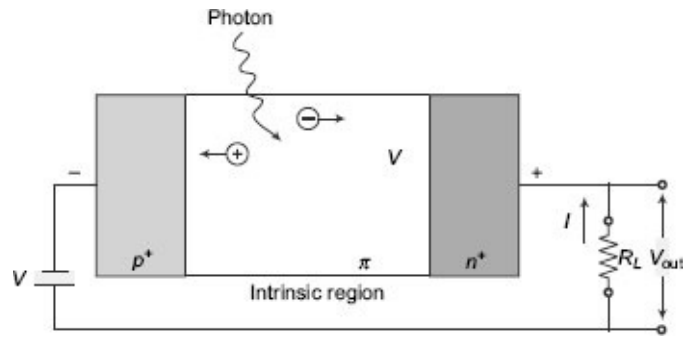

Figure 18.6 Theory of operation, PIN photodiode

2. Avalanche Diode/Avalanche PhotoDiode (APD)

Avalanche photodiodes are used where very weak light signals have to be amplified, and converted into a strong electrical signal. These diodes work on higher operating voltages, i.e. reverse-bias voltage is very high, now whenever a small amount of light energy falls on the intrinsic region, avalanche breakdown occurs and hence large reverse bias current flows through the circuit. The main advantages of APD are good output at low light levels and a wide dynamic range—it can handle high and low light levels. The disadvantages of APDs are higher noise levels, higher cost, requires higher operating voltages and its decreases of gain with an increasing temperature.

Operating Principles Avalanche photodiodes use semiconductor junction detectors with internal gain through avalanche current multiplication. A very high reverse bias voltage (50–300 volts) is applied to a $p-n$ junction. A photon is absorbed in the depletion region, creating a free electron and a free hole. These charges accelerate in the strong electric field. When they

collide with neutral atoms in the crystal lattice, their kinetic energy is sufficient to raise electrons across the band gap and create additional electron-hole pairs. These secondary charges also accelerate creating more electron-hole pairs. In this way, the current produced by one photon is multiplied.

The p^+ and n^+ layers are highly doped regions with very small voltage drops as shown in [Figure 18.7](#). The depletion region is lightly doped, almost intrinsic. Most of the photons are absorbed in this area, forming electron-hole pairs. The electrons move to the p^- region that has been depleted of free charge by the large reverse voltage. The depletion region at the $p^+ - n^+$ junction effectively reaches right through the p -layer. The strong electric fields across the p -layer cause avalanche multiplication of the electrons. The holes produced drift across the p layer to the p^+ electrode but do not cause further multiplication. Because this structure limits the charge carrier multiplication to electrons only, it has better noise performance.

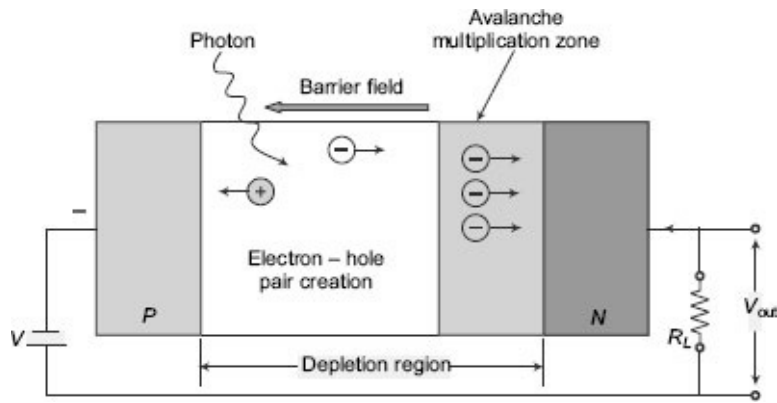

Figure 18.7 Theory of operation, avalanche photodiode

18.4

FIBRE OPTIC POWER MEASUREMENT

18.4.1 Optical Power

The fundamental unit of measure used in fibre optics is light power. As with electric power, optic power is measured in watts.

For light, the total energy Q is given by

$$Q = NQ_p$$

where, Q_p is the energy of a single photon and N is the number of photons

Therefore,

$$\text{Power} = \frac{d(NQ_p)}{dt} \quad (18.3)$$

Power Meter

Power in a fibre optic system is like voltage in an electrical circuit—it's what makes things happen. It is important to have enough power, but not too much. Too little power and the receiver may not be able to distinguish the signal from noise; too much power overloads the receiver and causes errors too.

Measuring power requires only a power metre (most come with a screw-on adapter that matches the connector being tested) and a little help from the network electronics to turn on the transmitter. During the measurement of power, the metre must be set to the proper range (usually dBm, sometimes microwatts, but never “dB” a relative power range used only for testing loss) and the proper wavelengths matching the source being used. Figure 18.8 shows the technique used in the measurement of optical power.

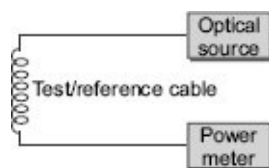

Figure 18.8 Measurement of optical power

To measure power, attach the metre to the cable that has the output you want to measure. That can be at the receiver to measure receiver power, or to a reference test cable

(tested and known to be good) that is attached to the transmitter, acting as the “source”, to measure transmitter power. A typical power metre is shown in Figure 18.9. Turn on the transmitter/source and note the power the metre measures. Compare it to the specified power for the system and make sure it has enough power but not too much.

For the power metre as shown in Figure 18.9, the wavelength is adjustable over the three windows and some offer a facility to step up and down by small increments. This allows the fibre characteristics to be quoted at any required wavelength. It is a ‘nice to have’ rather than an essential feature. The power levels can be indicated in mW or in decibels as dBm, relative to one milliwatt or as dBr, relative to a previously noted value. They are available with internal memories to store the day’s work and a thermal printer for hard copies.

If the light source and power metre are to be used to ^{Measured power} check an installation or repair on a commercial basis, the customer will need assurance that reading of the power metre is correct. The proof of this is provided by a calibration certificate for each instrument which must be renewed at intervals, usually annually. The calibration must be carried out by an authorised company whose instruments themselves are calibrated against the appropriate national standards. In this way, we can trace the accuracy back to its source.

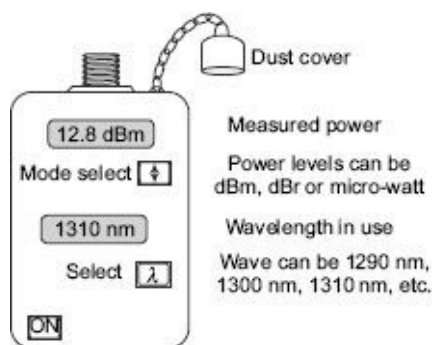

Figure 18.9 Typical power metre

18.4.2 Measurement of Loss

It is basically the difference between the power coupled into the cable at the transmitter end and what comes out at the receiver end. Testing for loss requires measuring the optical power lost in a cable (including connectors, splices, etc.) with a fibre optic source and power metre by connecting the cable being tested to a known good reference cable.

For loss measurement, a power metre along with a test source is required. The test source should match the type of source (LED or laser) and wavelength (850, 1300, 1550 nm).

There are two methods that are used to measure loss, which we call “single-ended loss” and “double-ended loss”. Single-ended loss uses only the launch cable, while double-ended loss uses a receive cable attached to the metre.

Single-ended loss is measured by mating the cable under test to the reference launch cable and measuring the power output at the far end with the metre. By doing this, total loss is being measured that is loss of the connector mated to the launch cable and the loss of any fibre, splices or other connectors in the cable under test. This method is described

in [Figure 18.10](#). Reverse the cable to test the connector on the other end.

For the measurement of double-ended loss attach the cable to test between two reference cables, one attached to the source and one to the metre. In this way, two connectors' losses are being measured one on each end, plus the loss of all the cable or cables in between. This method is shown in [Figure 18.11](#).

We also need one or two reference cables, depending on the test. The accuracy of the measurement will depend on the quality of your reference cables. Reference cables always need to be tested by the single-ended method discussed earlier, to ensure they are good before starting the test of other cables.

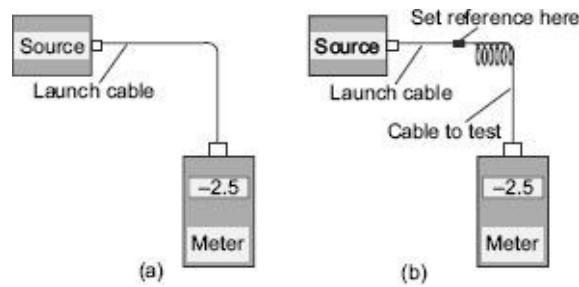

Figure 18.10 Single ended loss measurement

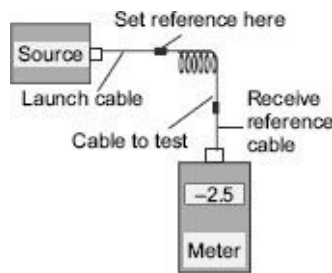

Figure 18.11 Double ended loss measurement

Example 18.1

Calculate the approximate loss at wavelengths of 1300 nm and 1550 nm for a optical system having 2 connectors, 2 splices and a single-mode optical fibre with a length of 10 km.

Solution

- For each connector, loss is 0.5 dB.
- For each splice, loss is 0.2 dB
- For the single-mode fibre, the loss is about 0.5 dB per km for 1300 nm sources, and 0.4 dB per km for 1550 nm.

So approximate loss is

$$(0.5 \times 2 + 0.2 \times 2 + 10 \times 0.5) \text{ dB for 1300 nm wavelength}$$

$$= 6.4 \text{ dB}$$

and

$$(0.5 \times 2 + 0.2 \times 2 + 10 \times 0.4) \text{ dB for 1550 nm wavelength}$$

$$= 5.4 \text{ dB}$$

18.4.3 Optical Time Domain Reflectometre (OTDR)

The most commonly used and best recognised method of analysing the state of a fibre optic link is to test it with an Optical Time domain Reflectometre (OTDR). The OTDR uses backscattered light of the fibre to imply loss. The OTDR works like RADAR, sending a high power laser light pulse down the fibre and looking for return signals from backscattered light in the fibre itself or reflected light from the connector or splice interfaces. By measuring the time it takes for the reflected light to return to the source and knowing the refractive index of the fibre, it is possible to calculate the distance to the reflection point.

When this instrument is connected to one end of any fibre optic system up to 250 km in length, within a few seconds, it is able to measure the overall loss, or the loss of any part of a system, the overall length of the fibre and the distance between any points of interest.

1. Operating Principle

As light travels along the fibre, a small proportion of it is lost by Rayleigh scattering. As the light is scattered in all directions, some of it just happens to return back along the fibre towards the light source. This returned light is called *backscatter*. The backscatter power is a fixed proportion of the incoming power and as the losses take their toll on the incoming power, the returned power also diminishes as shown in Figure 18.12.

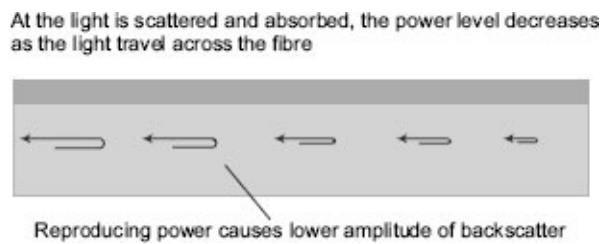

Figure 18.12 Loss due to Rayleigh scattering

The OTDR can continuously measure the returned power level and hence deduce the losses encountered on the fibre. Any additional losses such as connectors and fusion splices have the effect of suddenly reducing the transmitted power on the fibre and hence causing a corresponding change in backscatter power. The position and the degree of the losses can be ascertained.

Example 18.2

An optical fibre has a core of refractive index of 1.5. When the fibre is being tested with an OTDR system, it shows a sharp fault peak after with delay of 1.4 μs . Find the possible distance of fault.

Solution Travelling speed of light through the core is

$$= \frac{\text{Speed of light in the free space}}{\text{Refractive index of the core}} = \frac{3 \times 10^8}{1.5} = 2 \times 10^8 \text{ ms}^{-1}$$

This means that it will take 5 ns to travel the distance of 1 m.

If the OTDR measures a time delay of 1.4 ms then the distance travelled by the light is

$$= \frac{1.4 \times 10^{-6}}{5 \times 10^{-9}} = 280 \text{ m}$$

The 280 metres is the total distance travelled by the light and is the ‘onwards and return’ distance. The fault location is therefore only 140 m.

2. Inside the OTDR

In general, an OTDR system has the following inside components:

(a) **Timer** The timer produces a voltage pulse which is used to start the timing process in the display at the same moment as the laser is activated.

(b) **Pulsed Laser** The laser is switched on for a brief moment, the ‘on’ time being between 1 ns and 10 ms. The wavelength of the laser can be switched to suit the system to be investigated.

(c) **Directive Coupler** The directive coupler allows the laser light to pass straight through into the fibre under test. The backscatter from the whole length of the fibre approaches the directive coupler from the opposite direction. In this case, the mirror surface reflects the light into the avalanche photodiode (an APD). The light has now been converted into an electrical signal.

(d) **Amplifying and Averaging** The electrical signal from the APD is very weak and requires amplification before it can be displayed. The averaging feature is quite interesting and we will look at it separately towards the end of this chapter.

(e) **Display** The amplified signals are passed on to the display. The display is either a Cathode Ray Tube (CRT) like an oscilloscope or a computer monitor, or a liquid crystal as in calculators and laptop computers. They display the returned signals on a simple *XY* plot with the range across the bottom and the power level in decibels up the side.

(f) **Data Handling** An internal memory or a floppy disk drive can store the data for later analysis. The output is also available via an RS232 link for downloading to a computer. In addition, many OTDRs have an onboard printer to provide hard copies of the information on the screen. This provides useful ‘before and after’ images for fault repair as well as a record of the initial installation. Inside components of a typical OTDR system are shown in [Figure 18.13](#).

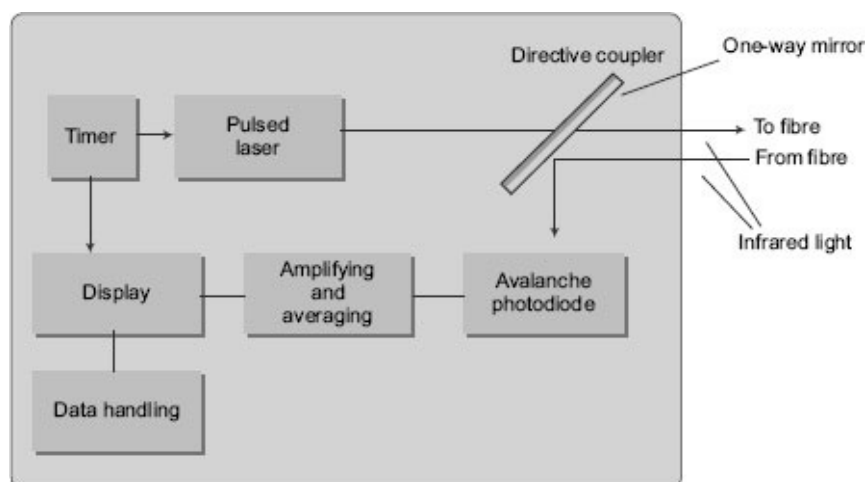

Figure 18.13 Functional block diagram of an OTDR system

3. Measurement Using OTDR

Impurities in the glass will cause a continuous low level reflection as the light travels

through the glass fibre. This is referred to as backscatter. The correct technical term of this is *Rayleigh scattering*. The strength of the backscatter signal received at the source gradually drops, as the pulse moves away from the source. This is seen on an OTDR as a near linear drop in the received reflected signal and the slope of this linear drop is the attenuation of the fibre (dB per km). [Figure 18.14](#) illustrates a typical reflection curve for an OTDR and notes the backscatter. Generally, an OTDR will not provide accurate readings of irregularities and losses in the fibre for the first 15 m of the cable. This is because the pulse length and its rise time from the OTDR are comparatively large when compared to the time it takes for the pulse to travel the short distance to the point of reflection within this 15 m and back. To overcome this problem, a reel of cable is inserted between the OTDR and the link to be tested. When reading the OTDR screen, the first length of cable is ignored and is referred to as the *dead band*. With reference to the OTDR plot in [Figure 18.14](#), the Y-axis of the plot shows the relative amplitude of the light signal that is reflected back to the source and the X-axis represents time. The time base is directly translated and displayed as distance by the OTDR.

The sudden peaks that appear along the slope are the points where reflections have occurred and the light that has reflected back to the source is stronger than the backscatter. There are five main reflection points illustrated in [Figure 18.14](#). In their order of decreasing magnitude, they are

1. Reflection from the unterminated end of the fibre
2. Reflection from a connector
3. Reflection from a splice
4. Reflection from a hairline crack in the fibre
5. Backscatter

After each of the reflections, the slope of the attenuation curve drops suddenly. This drop represents the loss introduced by the connector, splice or imperfection in the fibre. Point (6) noted in [Figure 18.14](#) illustrates a splice where the cores of fibres are well matched for light travelling in the direction away from the source. This splice has no reflection but just a loss introduced by the splice. The type of drop at the point (6) in the attenuation curve could also be caused by a sharp bend in the fibre where light escapes out of the fibre at the bend and is not reflected back. Some types of faults in the fibre will also cause similar results.

Point (7) noted in [Figure 18.14](#) shows the noise floor of the instrument. This is the lowest sensitivity of a received signal that the device can accept. Measurements made close to this level are not very accurate. OTDR testing can provide very accurate fault analysis over almost any length of fibre. It is important that the deadband roll of cable is always inserted between the OTDR and the link before making the measurement. On the better quality instruments, a resolution of 1 m for fault location and .01 dB for in-line losses can be obtained. Some instruments will operate with a range of up to 400 km.

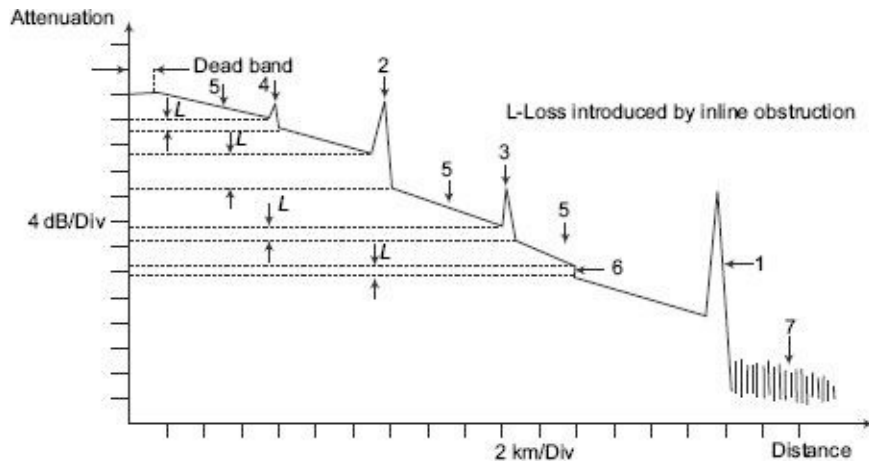

Figure 18.14 Trace from an OTDR

EXERCISE

Objective-type Questions

- Light passes through the fibre due to phenomena of
 - total internal reflection
 - reflection from the interface of two medium
 - transmission to the second medium
 - both transmission and reflection at the interface of two medium
- LEDs operating in the wavelength of 800–900 nm are mainly made of
 - GaAs
 - GaAlAs
 - GaAsP
 - InGaAsP
- The width of active region of LASER diode is comparatively
 - wider than LEDs
 - almost equal to LEDs
 - much wider than LEDs
 - narrower than LEDs
- PIN photodiodes are kept in
 - forward bias
 - reverse bias
 - connected circuit and no bias voltages are given
 - initially forward biased and then reverse biased
- Avalanche photodiodes have output voltage comparatively
 - lower than PIN photodiode
 - higher than PIN photodiode
 - higher than normal photodiode
 - higher than normal and PIN photodiode
- In OTDR response, the peaks of the reflected waveform do not occur due to
 - reflection from the unterminated end of the fibre

- (b) reflection from a connector
- (c) backscatter
- (d) reflection from the interface of core and cladding

Answers					
1. (a)	2. (b)	3. (d)	4. (b)	5. (d)	6. (d)

Short-answer Questions

1. How do light waves travel through an optical fibre? Explain with a proper diagram.
2. State the working principle of a *p-n* junction photodiode.
3. How are LASER diodes different from LEDs? How do LASER diodes generate LASER light?
4. How do PIN diodes work? What are the benefits of avalanche diodes and how do they work?
5. How is the optical power in a fibre optic network measured? Explain in brief.
6. State the procedures adopted during the measurement of fibre loss.
7. How does the OTDR work? Explain in brief with a diagram.
8. Draw the functional block diagram of a typical OTDR system and explain in brief about each element.
9. How are different reflective components measured using an OTDR system?
10. Calculate the approximate loss at wavelengths of 800 nm and 900 nm for an optical system having 1 connector, 4 splices and a single-mode optical fibre with a length of 10 km.

Table of SI Units

- Table I. Basic units
- Table II. Derived units with assigned names
- Table III a. SI Units prefixes
- Table III b. Binary prefixes for bytes
- Table IV. Accepted non-SI units
- Table V. Accepted non-SI units with experimental values
- Table VI. Units deprecated by the SI

Table I *Basic Units*

<i>Quantity</i>	<i>Unit</i>	<i>Symbol</i>	<i>Definition</i>
Length	metre	m	1983, 17 th CGPM: The path travelled by light in vacuum during a time interval of 1/299792458 seconds. This fixes the speed of light to exactly 299792458 m/s.
Mass	kilogram	kg	1901, 3 rd CGPM: Mass of the platinum-iridium prototype at BIPM in Sevres.
Time	second	s	1968, 13 th CGPM: One second equals 9192631770 periods of the radiation due to the transition between the two hyperfine levels of the ground state of Cesium 133.
Electric current	ampere	A	1948, 9 th CGPM: Given two parallel, rectilinear conductors of negligible circular cross section positioned 1 m apart in vacuum, one ampere is the electric current which, passing through both of them, makes them attract each other by the force of 2×10^{-7} newtons per every metre of length. This fixes the permeability of vacuum to exactly $2\pi \times 10^{-7}$ H/m.
Temperature	kelvin	K	1968, 13 th CGPM: One degree K equals 1/273.16 of the thermodynamic temperature of the triple point of water.
Quantity of substance	mole	mol	1971, 14 th CGPM: The amount of a substance composed of as many specified elementary units (molecules, atoms) as there are atoms in 0.012 kg of Carbon 12.
Luminosity	candle	cd	1979, 16 th CGPM: The candle (or candela) is the luminous intensity, in a given direction, of a source that emits monochromatic radiation of $540 \cdot 10^{12}$ hertz frequency and that has a radiant intensity in that direction of 1/683 W/sr.

Table II *Derived units with assigned names*

<i>Quantity</i>	<i>Unit</i>	<i>Symbol</i>	<i>Equals</i>	<i>Definition / Note</i>
Space and Time				
Plane angle	radian	rad		The plain angle which, when centered in a circle, cuts off an arc whose length is equal to the circle radius.
Solid angle	steradian	sr		The solid angle which, when centered in a sphere, cuts off a cap whose surface equals that of a square having the radius as side.
Frequency	hertz	Hz	1 s^{-1}	[number of events or cycles]/[time].
Mechanics				
Force	newton	N	1 kg.m.s^{-2}	[mass].[acceleration].
Pressure	pascal	Pa	1 N.m^{-2}	[force]/[area]. Also: stress.
Energy	joule	J	1 N.m	[force].[length]. Also: Work, Heat
Power	watt	W	1 J.s^{-1}	[energy]/[time]. Also: Radiant flux
Thermodynamics				
Temperature	celsius	$^{\circ}\text{C}$	1 K	$T [^{\circ}\text{C}] = T [\text{K}] - 273.15$ (the offset is exact!).
Electromagnetism				
Charge	coulomb	C	1 A.s	[current].[time].
Potential	volt	V	1 W.A^{-1}	[power]/[current]. Only differences are measurable!
Resistance	ohm	Ω	1 V.A^{-1}	$[\Delta\text{potential}]/[\text{current}]$.
Conductance	siemens	S	1 A.V^{-1}	[current]/ $[\Delta\text{potential}]$.
Capacitance	farad	F	1 C.V^{-1}	[charge]/ $[\Delta\text{potential}]$.
Inductance	henry	H	1 V.s.A^{-1}	$[\Delta\text{potential}]/[\text{rate of change of current}]$.
Magnetic flux	weber	Wb	1 J.A^{-1}	[energy]/[current].
Magnetic flux density	tesla	T	1 Wb.m^{-2}	[magnetic flux]/[area]. Also: magnetic induction .
Optics				
Luminous flux	lumen	lm	1 cd.sr	[luminosity].[solid angle].
Illuminance	lux	lx	1 lm.m^{-2}	[luminous flux]/[area].
Convergence	dioptry	dioptry	1 m^{-1}	Inverse of focal length.
Radioactivity and Radiation				
Activity	becquerel	Bq	1 s^{-1}	[number of decay events]/[time].
Absorbed dose	gray	Gy	1 J.kg^{-1}	[energy]/[mass].
Dose equivalent	sievert	Sv	1 J.kg^{-1}	[energy]/[mass]. Absorbed dose re-normalized by biological effects.
Chemistry				
Katalytic activity	katal	kat	1 mol.s^{-1}	[quantity of substance]/[time].

Table IIIa *SI Units prefixes*

Prefix	Symbol	Factor	Examples of usage	Origin
Yotta	Y	10^{24}	0.2 YW, 1.23Y [W]	Greek 'octo' (eight, 1000^8)
Zetta	Z	10^{21}	3.33 Zs, 3.33Z [s]	French 'sept' (seven, 1000^7)
Exa	E	10^{18}	1.23 Ekg, 1.23E [kg]	Greek 'six' (1000^6)
Peta	P	10^{15}	7.5 Ps, 7.5P [s]	Greek 'five' (1000^5)
Tera	T	10^{12}	0.5 Tm, 0.5T [m]	Greek 'teras' = monster
Giga	G	10^9	1.2 GΩ, 1.2G [Ω]	Greek 'gigas' = giant
Mega	M	10^6	7 MW, 7M [W]	Greek 'megas' = large
Kilo	K, k	10^3	33 km, 33K [m]	Greek 'kilioi' = thousand
hecto	h	100	Deprecated by SI	Greek 'hekaton' = hundred
deca	da	10	Deprecated by SI	Greek 'deka' = ten
deci	d	0.1	Deprecated by SI	Latin 'decima pars' = one tenth
centi	c	0.01	Deprecated by SI	Latin 'centesima pars' = one hundredth
milli	m, k	10^{-3}	22 mm , 1.2m [m]	Latin 'millesima pars' = one thousandth
micro	μ, u	10^{-6}	2.7 uJ , 2.7μ [J]	Greek 'mikros' = small
nano	n	10^{-9}	2.2 nF, 2.2n [F]	Latin 'nanus' = dwarf
pico	p	10^{-12}	1.5 pA, 1.5p [A]	Spanish 'pico' = minimal measure
femto	f	10^{-15}	4.8 fs, 4.8f [s]	Danish and Norwegian 'femten' = fifteen (10^{-15})
atto	a	10^{-18}	1.2 ag, 1.2a [g]	Danish and Norwegian 'atten' = eighteen (10^{-18})
zepto	z	10^{-21}	0.2 zm, 1.2z [m]	French 'sept' (seven, 1000^{-7})
yocto	y	10^{-24}	1 ys, 1y [s]	Greek 'octo' (eight, 1000^{-8})

Table IIIb Binary prefixes for bytes

Prefix	Symbol	Factor	Value	Examples
Kilo	KB	2^{10}	1024	12345 KB = 12 641 280 bytes
Mega	MB	2^{20}	1 048 576	420 MB fits in my PC's dynamic RAM
Giga	GB	2^{30}	1 073 741 824	16 GB flash-memory pen drive costs \$20
Tera	TB	2^{40}	1 099 511 627 776	3.9 TB hard disks are a reality
Peta	PB	2^{50}	1 125 899 906 842 624	13.5 PB is the CIA total memory capacity
Exa	EB	2^{60}	1 152 921 504 606 846 976	1 EB is still a bit out of reach (AD 2010)
Zetta	ZB	2^{70}	1 180 591 620 717 411 303 424	How many ZB to hard copy a human being ???
Yotta	YB	2^{80}	1 208 925 819 614 629 174 706 176	1 YYB is still nothing compared with the universe!

Table IV Accepted non-SI units

Unit	of	Symbol	Equals	Definition/Note
Degree of arc	plain angle	°	($\pi/180$) rad	
Minute of arc	plain angle	'	(1/60)°	
Second of arc	plain angle	"	(1/60)'	
Minute	time	min	60 s	
Hour	time	h	60 min	
Day	time	d	24 h	Notice that the duration of a day is not linked to the earth's motion!
Litre	volume	L, l	0.001 m ³	Often used sub-units are decilitre (dl) and centilitre (cl) .
Gram	mass	g	0.001 kg	A tolerated anomaly : the of mass (kg) has a .
Ton	mass	t	1000 kg	More precise term: metric ton .
Bit	information	bit	–	The smallest, dimensionless quantum of information
Baud rate	info flux	Baud	1 bits.s ⁻¹	[amount of information]/[time]
Neper	ratio	Np	log(A/B)	Measure of a ratio A/B. The logarithms are in base 10.
Bel	ratio	B	0.5 Np	Mostly used as decibel (dB) : 1 dB = (1/20) Np.

Table V Accepted non-SI units with experimental values

Unit	of	Symbol	Equals	Note
Electron volt	energy	eV	$1.60217733(49) \times 10^{-19}$ J	Energy to move an electron across a potential difference of 1 V.
Astronomical unit	length	au, AU, ua	$1.49597870(30) \times 10^{11}$ m	Mean earth-to-sun distance. Also denoted as ua .
Atomic mass unit	mass	u	$1.6605402(10) \times 10^{-27}$ kg	1/12 of the rest mass of an unbound ¹² C atom in ground state.

Table VI Units deprecated by the SI

Unit	of	Symbol	Equals	Note
Nautical mile	length	mile	1852 m	
Knot	velocity	knot	1 mile.h ⁻¹	A nautical unit.
Are	area	are	100 m ²	
Hectar	area	ha	100 are	10000 m ²
Bar	area	bar	100000 Pa	Almost 1 atm = 101325 Pa (an obsolete unit)
Calory	energy	cal	4.1868 J	Note: the conversion factor is fixed by convention.
Ångström	length	Å	10 ⁻¹⁰ m	Used in atomic and molecular physics.
Barn	area	b	10 ⁻²⁸ m ²	Used in particle physics (collision cross sections).
Radioactivity and Radiation				
Curie	Radioactivity	b	3.7×10^{10} Bq	Note: the conversion factor is fixed by convention.
Röntgen	Radiation dose	R	0.000258 Ci.kg ⁻¹	Note: the conversion factor is fixed by convention.
Rad	Radiation dose	rad	0.01 Gy	
Rem	Equivalent dose	rem	0.01 Sv	

UNIT CONVERSION TABLE

HOW TO READ THIS TABLE: The table provides conversion factors to SI units. These factors can be considered as unity multipliers. For example:

Length: m/X

0.0254 in 0.3048 ft

means that

$$1 = 0.0254 \text{ (m/in)}$$

$$1 = 0.3048 \text{ m/ft}$$

The SI units are listed immediately after the quantity; in this case: Length: m/X. The m stands for metre, and the “X” designates the non-SI units for the same quantity. These non-SI units follow the numerical conversion factors.

Example A.1

To calculate how many metres are in 10 ft, the table provides the conversion factor as 0.3048 m/ft.

Hence, multiply

$$10 \text{ ft} \times \{0.3048 \text{ m/ft}\} = 3.048 \text{ m}$$

Example A.2

Convert thermal conductivity of 10 kcal/h-m-°C to SI units. Select the appropriate conversion factor for these units,

$$10 \text{ (kcal/h-m-°C)} \times \{1.163 \text{ (w/m-K)/(kcal/h-m-°C)}\} = 11.63 \text{ w/m-K}$$

Length: m/X

0.01 cm	1.0E-06 μm	1.0E-10 Å	0.3048 ft	1 609.3 mi	0.0254 in	0.9 144 yd
---------	------------	-----------	-----------	------------	-----------	------------

Mass: kg/X

1.0E-03 g	0.4536 lbm	6.48E-05 grain	0.02835 oz
-----------	------------	----------------	------------

Time: s/X

60.0 min	3600 h	86,400 day	3.156E+07yr
----------	--------	------------	-------------

Temperature: K/X (difference)

0.5555 °R	0.5555 °F	1.0 °C
-----------	-----------	--------

Area: m²/X

1.0E-04 cm ²	1.0E-12 μm ²	0.0929 ft ²	6.452E-04 in ²	0.8361 yd ²	4,047 acre
-------------------------	-------------------------	------------------------	---------------------------	------------------------	------------

Volume: m³/X

1.0E-06 cm ³	1.0E-03 lit	1.0E-18 μm ³	0.02832 ft ³	1.639E-05 in ³	3.785E-03 gal (US)
-------------------------	-------------	-------------------------	-------------------------	---------------------------	--------------------

Flow Rate, Volume: (m /s)/X

1.0E-06 cm ³ /s	0.02832 cfs	1.639E-05 in ³ /s	4.72E-04 cfm	7.87E-06 cfh	3.785E-03 gal/s
----------------------------	-------------	------------------------------	--------------	--------------	-----------------

Specific Volume: (m³/kg)/X

1.0E-03 cm ³ /g	1.0E-15 μm ³ /g	0.0624 ft ³ /lbm
----------------------------	----------------------------	-----------------------------

Velocity: (m/s)/X

0.01 cm/s	2.78E-04 m/h	0.278 km/h	0.3048 ft/s	0.447 mi/h
-----------	--------------	------------	-------------	------------

Acceleration: (m/s²)/X

0.01 cm/s ²	7.716E-08 m/h ²	0.3048 ft/s ²	8.47E-05 ft/min ²
------------------------	----------------------------	--------------------------	------------------------------

Momentum: (kg-m/s)/X

1.0E-05 g-cm/s	0.1383 lbm-ft/s	2.30E-03 lbm-ft/min
----------------	-----------------	---------------------

Angular Velocity: (rad/s)/X

0.01667 rad/min	2.78E-04 rad/h	0.1047 rev/min
-----------------	----------------	----------------

Angular Acceleration: (rad/s²)/X

2.78E-04 rad/min ²	7.72E+08 rad/h ²	1.74E-03 rev/min ²
-------------------------------	-----------------------------	-------------------------------

Momentum, Angular: (kg-m²/s)/X

1.0E-07 g-cm ² /s	0.04215 lbm-ft ² /s	7.02E-04 lbm-ft ² /min
------------------------------	--------------------------------	-----------------------------------

Mass Moment of Inertia: (kg-m)/X

1.0E-07 g-cm ²	0.04214 lbm-ft ²	1.355 lbf-ft-s ²	2.93E-04 lbm-in ²	0.11 lbf-in-s ²
---------------------------	-----------------------------	-----------------------------	------------------------------	----------------------------

Flow Rate, Mass: (kg/s)/X

1.0E-03 g/s	2.78E-04 kg/h	0.4536 lbm/s	7.56E-03 lbm/min	1.26E-01 lbm/hr
-------------	---------------	--------------	------------------	-----------------

Density: (kg/m³)/X

1,000.0 g/cm ³	16.02 lbm/ft ³	119.8 lbm/gal	27,700 lbm/in ³	2.289E-3 grain/ft ³
---------------------------	---------------------------	---------------	----------------------------	--------------------------------

Flow Rate, Mass/Volume: (kg/m -s)/X

1,000 g/cm ³ -s	0.2778 g/cm ³ -h	16.02 lbm/ft ³ -s	4.45E-03 lbm/ft ³ -h
----------------------------	-----------------------------	------------------------------	---------------------------------

Specific Volume: (m³/kg)/X

1.0E-03 cm ³ /g	0.06243 ft ³ /lbm
----------------------------	------------------------------

Force: N/X

1.0E-05 dyn	1 kg-m/s ²	9.8067 kg(force)	4.448 lbf	8,896 ton(force)
-------------	-----------------------	------------------	-----------	------------------

Surface Tension: (N/m)/X

1.0E-03 dyn/cm	14.6 lbf/ft	175.0 lbf/in
----------------	-------------	--------------

Pressure, Stress: (N/m²)/X

0.1 dyn/cm ²	9.8067 kg(f)/m ²	1.0E+05 bar	1.0133E+05 std. atm	47.88 lbf/ft ²
6,894 lbf/in ²	1.38E+07 ton(f)/in ²	133.3 torr, mm Hg	3,386 in Hg	

Torque: N-m/X

1.0E-07 dyn-cm	1.356 lbf-ft	2.989 kg(f)-ft
----------------	--------------	----------------

Dynamic Viscosity: (Kg/m-s)/X

1 N-s/m ²	0.1 P	2.78E-04 kg/m-h	1.488 lbm-ft-s	47.91 lbf-s/ft ²
----------------------	-------	-----------------	----------------	-----------------------------

Dynamic Viscosity: (g/cm-s)/X

1 P

Energy: J/X

3.6E+06 kWh	4.187 cal	4187 kcal	1.0E-07 erg	1055 Btu	2.685E+06 hp-h	1.60207E-19 eV
-------------	-----------	-----------	-------------	----------	----------------	----------------

Power: W/X

4.187 cal/s	4187 kcal/s	1.0E-07 erg/s	1.356 ft-lbf/s	0.293 Btu/h
1055 Btu/s	745.8 hp	0.1130 in-lbf/s	3517 ton	

Specific Heat, Gas Constant: (J/kg-K)/X

	4187 cal/g-°C	1.0E-04 erg/g-°C	4187 Btu/lbm-°F	5.38 ft-lbf/lbm-°F
--	---------------	------------------	-----------------	--------------------

Thermal Conductivity: (W/m-K)/X

418.7 cal/s-cm-°C	1.163 kcal/h-m-°C	1.0E-05 erg/s-cm-°C	1.731 Btu/h-ft-°F
0.1442 Btu-in/h-ft ² -°F	2.22E-03 ft-lbf/h-ft-°F		

Heat Transfer Coefficient: (W/m²-K)/X

41,868 cal/s-cm ² -°C	1.163 kcal/h-m ² -°C	1.0E-03 erg/s-cm ² -°C	5.679 Btu/h-ft ² -°F	12.52kcal/h-ft ² -°C
----------------------------------	---------------------------------	-----------------------------------	---------------------------------	---------------------------------

B.1**INTRODUCTION**

Although many students know the decimal (base 10) system, and are very comfortable with performing operations using this system, it is important for students to understand that the decimal system is not the only system. By studying other number systems such as binary (base 2), octal (base 8), and hexadecimal (base 16), students will gain a better understanding of how number systems work in general. When discussing how a computer stores information, the binary number system becomes very important since this is the system that computers use. It is important that students understand that computers store and transmit data using electrical pulses, and these pulses can take two forms: “on” (1) or “off” (0).

The following topics treat the manipulation of numbers represented in different bases as well as the binary representation of negative integers and floating-point numbers.

B.2**DIFFERENT BASES**

The following are a series of examples that should help students understand how numbers are represented using different bases.

1. The Decimal System

In everyday life, we use a system based on decimal digits (0, 1, 2, 3, 4, 5, 6, 7, 8, 9) to represent numbers and refer to the system as the decimal system. Consider what the number 83 means. It means eight tens plus three:

$$83 = (8 \times 10) + 3$$

The number 4728 means four thousands, seven hundreds, two tens, plus eight:

$$4728 = (4 \times 1000) + (7 \times 100) + (2 \times 10) + 8$$

The decimal system is said to have a base, or radix, of 10. This means that each digit in the number is multiplied by 10 raised to a power corresponding to that digit’s position:

$$83 = (8 \times 10^1) + (3 \times 10^0)$$

$$4728 = (4 \times 10^3) + (7 \times 10^2) + (2 \times 10^1) + (8 \times 10^0)$$

The same principle holds for decimal fractions but negative powers of 10 are used. Thus, the decimal fraction 0.256 stands for 2 tenths plus 5 hundredths plus 6 thousandths:

$$0.256 = (2 \times 10^{-1}) + (5 \times 10^{-2}) + (6 \times 10^{-3})$$

A number with both an integer and fractional part has digits raised to both positive and negative powers of 10:

$$472.256 = (4 \times 10^2) + (7 \times 10^1) + (2 \times 10^0) + (2 \times 10^{-1}) + (5 \times 10^{-2}) + (6 \times 10^{-3})$$

In general, for the decimal representation of $X = \{ \dots d_2d_1d_0.d_{-1}d_{-2}d_{-3} \dots \}$, the value of X is

$$X = \sum_i d_i \times 10^i$$

2. The Binary System

In the decimal system, 10 different digits are used to represent numbers with a base of 10. In the binary system, we have only two digits, 1 and 0. Thus, numbers in the binary system are represented to the base 2.

To avoid confusion, we will sometimes put a subscript on a number to indicate its base. For example, 83_{10} and 4728_{10} are numbers represented in decimal notation, or more briefly, decimal numbers. The digits 1 and 0 in binary notation have the same meaning as in decimal notation:

$$0_2 = 0_{10}$$

$$1_2 = 1_{10}$$

To represent larger numbers, as with decimal notation, each digit in a binary number has a value depending on its position:

$$10_2 = (1 \times 2^1) + (0 \times 2^0) = 2_{10}$$

$$11_2 = (1 \times 2^1) + (1 \times 2^0) = 3_{10}$$

$$100_2 = (1 \times 2^2) + (0 \times 2^1) + (0 \times 2^0) = 4_{10}$$

and so on. Again, fractional values are represented with negative powers of the radix:

$$1001.101_2 = 2^3 + 2^0 + 2^{-1} + 2^{-3} = 9.625_{10}$$

In general, for the binary representation of $Y = \{ \dots b_2b_1b_0.b_{-1}b_{-2}b_{-3} \dots \}$, the value of Y is

$$Y = \sum_i b_i \times 2^i$$

3. Converting between Binary and Decimal

It is a simple matter to convert a number from binary notation to decimal notation. In fact, we showed several examples in the previous subsection. All that is required is to multiply each binary digit by the appropriate power of 2 and add the results.

(a) Binary to Decimal

For the integer part, recall that in binary notation, an integer represented by

$$b_{m-1}b_{m-2}\dots b_2b_1b_0 \quad b_i = 0 \text{ or } 1$$

has the value

$$(b_{m-1} \times 2^{m-1}) + (b_{m-2} \times 2^{m-2}) + \dots + (b_1 \times 2^1) + b_0$$

For Example:

$$\begin{aligned} 101001_2 &= 1 \times 2^5 + 0 \times 2^4 + 1 \times 2^3 + 0 \times 2^2 + 0 \times 2^1 + 1 \times 2^0 \\ &= 32 + 8 + 1 \\ &= 41_{10} \end{aligned}$$

(b) Decimal to Binary

Suppose it is required to convert a decimal integer N into binary form. If we divide N by 2, in the decimal system, and obtain a quotient N_1 and a remainder R_0 , we may write

$$N = 2 \times N_1 + R_0 \quad R_0 = 0 \text{ or } 1$$

Next, we divide the quotient N_1 by 2. Assume that the new quotient is N_2 and the new remainder R_1 . Then

$$N_1 = 2 \times N_2 + R_1 \quad R_1 = 0 \text{ or } 1$$

so that
$$N = 2(2N_2 + R_1) + R_0 = (N_2 \times 2^2) + (R_1 \times 2^1) + R_0$$

If next
$$N_2 = 2N_3 + R_2$$

we have
$$N = (N_3 \times 2^3) + (R_2 \times 2^2) + (R_1 \times 2^1) + R_0$$

Because $N > N_1 > N_2 \dots$, continuing this sequence will eventually produce a quotient $N_{m-1} = 1$ (except for the decimal integers 0 and 1, whose binary equivalents are 0 and 1, respectively) and a remainder R_{m-2} , which is 0 or 1. Then

$$N = (1 \times 2^{m-1}) + (R_{m-2} \times 2^{m-2}) + \dots + (R_2 \times 2^2) + (R_1 \times 2^1) + R_0$$

Example:

Convert 11_{10} to its binary equivalent.

Quotient	Remainder
$11/2 = 5$	1
$5/2 = 2$	1
$2/2 = 1$	0
$1/2 = 0$	1

Example:

Convert 21_{10} to its binary equivalent.

Quotient	Remainder
$21/2 = 10$	1
$10/2 = 5$	1
$5/2 = 1$	1
$2/2 = 1$	0
$1/2 = 0$	1

1
0
1
0
 $1_2 = 21_{10}$

For the fractional part, recall that in binary notation, a number with a value between 0 and 1 is represented by

$$0.b_{-1}b_{-2}b_{-3}\dots \quad b_i = 0 \text{ or } 1$$

has the value

$$(b_{-1} \times 2^{-1}) + (b_{-2} \times 2^{-2}) + (b_{-3} \times 2^{-3}) \dots$$

This can be rewritten as

$$2^{-1} \times (b_{-1} + 2^{-1} \times (b_{-2} + 2^{-1} \times (b_{-3} + \dots$$

This expression suggests a technique for conversion. Suppose we want to convert the number F ($0 < F < 1$) from decimal to binary notation. We know that F can be expressed in the form

$$F = 2^{-1} \times (b_{-1} + 2^{-1} \times (b_{-2} + 2^{-1} \times (b_{-3} + \dots$$

If we multiply F by 2, we obtain:

$$2 \times F = b_{-1} + 2^{-1} \times (b_{-2} + 2^{-1} \times (b_{-3} + \dots$$

From this equation, we see that the integer part of $(2 \times F)$, which must be either 0 or 1 because $0 < F < 1$, is simply b_{-1} . So we can say $(2 \times F) = b_{-1} + F_1$, where $0 < F_1 < 1$ and where

$$F_1 = 2^{-1} \times (b_{-2} + 2^{-1} \times (b_{-3} + 2^{-1} \times (b_{-4} + \dots$$

To find b_{-2} , we repeat the process. Therefore, the conversion algorithm involves repeated multiplication by 2. At each step, the fractional part of the number from the previous step is multiplied by 2. The digit to the left of the decimal point in the product will be 0 or 1 and contributes to the binary representation, starting with the most significant digit. The fractional part of the product is used as the multiplicand in the next step.

This process is not necessarily exact; that is, a decimal fraction with a finite number of digits may require a binary fraction with an infinite number of digits. In such cases, the conversion algorithm is usually halted after a pre-specified number of steps, depending on the desired accuracy.

Example:

Convert 0.81_{10} to its equivalent binary value.

Product	Integer Part
$0.81 \times 2 = 1.62$	1
$0.62 \times 2 = 1.24$	1
$0.24 \times 2 = 0.48$	0
$0.48 \times 2 = 0.96$	0
$0.96 \times 2 = 1.92$	1
$0.92 \times 2 = 1.84$	1

0
1
1
0
0
1
 1_2

Thus, $0.81_{10} = 0.11011_2$ (approximately)

4. Hexadecimal Notation

Because of the inherent binary nature of digital computer components, all forms of data within computers are represented by various binary codes. However, no matter how convenient the binary system is for computers, it is exceedingly cumbersome for human beings. Consequently, most computer professionals who must spend time working with the actual raw data in the computer prefer a more compact notation.

What notation to use? One possibility is the decimal notation. This is certainly more compact than binary notation, but it is awkward because of the tediousness of converting between base 2 and base 10.

Instead, a notation known as hexadecimal has been adopted. Binary digits are grouped into sets of four. Each possible combination of four binary digits is given a symbol, as follows:

0000 = 0	1000 = 8
0001 = 1	1001 = 9
0010 = 2	1010 = A
0011 = 3	1011 = B
0100 = 4	1100 = C
0101 = 5	1101 = D
0110 = 6	1110 = E
0111 = 7	1111 = F

Because 16 symbols are used, the notation is called hexadecimal, and the 16 symbols are the **hexadecimal digits**.

A sequence of hexadecimal digits can be thought of as representing an integer in base 16.

In hexadecimal system, the possible digits are 0, 1, 2, 3, 4, 5, 6, 7, 8, 9, A, B, C, D, E, F

(**Note:** In base 10, A = 10, B = 11, C = 12, D = 13, E = 14, F = 15)

Thus,

$$\begin{aligned} 2C_{16} &= (2_{16} \times 16^1) + (C_{16} \times 16^0) \\ &= (2_{10} \times 16^1) + (12_{10} \times 16^0) \\ &= 44_{10} \\ 3B2C4 &= 3_{16} \times 16^4 + B_{16} \times 16^3 + 2_{16} \times 16^2 + C_{16} \times 16^1 + 4_{16} \times 16^0 \\ &= 3_{10} \times 16^4 + 11_{10} \times 16^3 + 2_{10} \times 16^2 + 12_{10} \times 16^1 + 4_{10} \times 16^0 \\ &= 242372_{10} \end{aligned}$$

Hexadecimal notation is used not only for representing integers. It is also used as a concise notation for representing any sequence of binary digits, whether they represent text, numbers, or some other type of data. The reasons for using hexadecimal notation are the following:

1. It is more compact than binary notation.
2. In most computers, binary data occupy some multiple of 4 bits, and hence some multiple of a single hexadecimal digit.
3. It is extremely easy to convert between binary and hexadecimal.

As an example of the last point, consider the binary string 110111100001. This is equivalent to

$$\begin{array}{cccc} 1101 & 1110 & 0001 & = \text{DE1}_{16} \\ \text{D} & \text{E} & \text{1} & \end{array}$$

This process is performed so naturally that an experienced programmer can mentally convert visual representations of binary data to their hexadecimal equivalent without written effort

5. Hexadecimal to Binary Conversion

Since one hexadecimal digit can be represented using four binary digits, we can convert each hexadecimal digit into a group of four binary digits.

2 A 4 E

$$2A4E_{16} = 0010\ 1010\ 0100\ 1110$$

$$= 10101001001110_2$$

Weston Frequency Meter

As the name suggests, the Weston frequency meter is an instrument using which unknown frequency of a signal can be measured. It is basically a moving-iron-type instrument which works on the principle that whenever the frequency changes, the current distribution changes between two parallel circuits, one of which is inductive and the other non-inductive. Any change in frequency changes the inductive impedance of the inductive arm causing current distribution to change between the two parallel paths. Figure C.1 shows the constructional details of a Weston frequency meter.

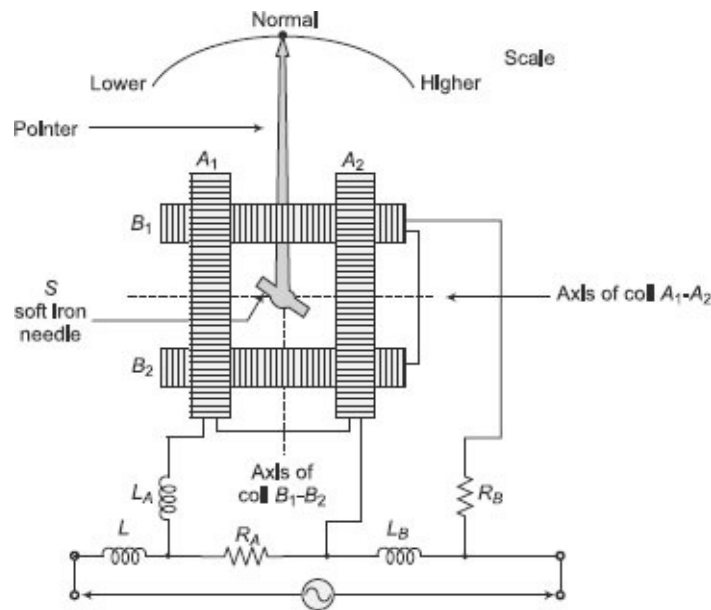

Figure C.1 Weston Frequency meter

The axes of the two coils A_1-A_2 and B_1-B_2 are mutually perpendicular. A soft iron needle that carries a pointer is placed at the central location within the coils. Coil A is connected in series with an inductance L_A across a non-inductive resistance R_A . Coil B is connected in series with a non-inductive resistance R_B across an inductance L_B . The other inductor L acts as a filter to remove any harmonics that may be present in the signal.

As supply is given to the system, the magnetic fields developed by the two coils are at right angles to each other. Depending on the strength of these two magnetic fields, a deflecting torque is developed that moves the soft iron needle and hence the pointer on a calibrated scale. The deflecting torque and hence the amount of deflection of the pointer thus depends on the magnitude of currents in the two coils.

Once the frequency deviates from a certain present value, the inductance values L_A and L_B change, but the resistances R_A and R_B remain the same. This makes the current distribution in the two coils to change from their initial preset values. Depending on the frequency, one coil becomes stronger than the other. Thus, the deflecting torque under such condition will be different from that in the normal case and the pointer will deviate either towards left or to the right indicating lower or higher frequency than the preset value respectively.

Solved Sample Question Papers

SOLVED QUESTION PAPER-1

1. Answer the following questions:

(2 × 10)

(a) Give two examples of each: (i) Absolute instrument (ii) Secondary instrument

(i) **Absolute instruments**—Tangent galvanometer, Absolute electrometer

(ii) **Secondary instruments**—Moving-coil instrument, Moving-iron instrument

(b) A wattmeter has a current coil of 0.03Ω resistance and a pressure coil of 6000Ω resistance. Calculate the percentage error if the wattmeter is so connected that (i) the current coil is on the load side, and (ii) the pressure coil is on the load side. The load takes 20 A at a voltage of 220 V and 0.6 power factor in each side.

Load specified is 20 A at 250 V with 0.6 power factor.

(i) Current Coil (CC) on load side

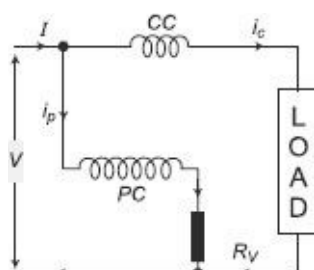

Figure 1

$$\begin{aligned} \text{True power} &= VI \cos \phi \\ &= 250 \times 20 \times 0.6 \\ &= 3000 \text{ W} \end{aligned}$$

$$\begin{aligned} \text{Power lost in CC} &= I^2 \times r_C \text{ (where } r_C \text{ is the resistance of CC)} \\ &= 20^2 \times 0.03 \\ &= 12 \text{ W} \end{aligned}$$

The wattmeter will thus read total power = 3000 + 12 = 3012 W

$$\text{Hence, error in measurement} = \frac{12}{3000} \times 100 \% = 0.4 \%$$

(ii) Pressure Coil (CC) on load side

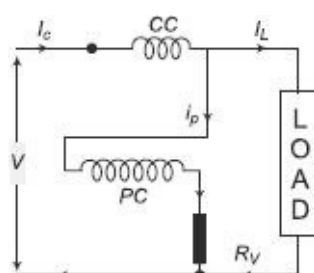

Figure 2

$$\text{True power} = 3000 \text{ W}$$

$$\begin{aligned}\text{Power lost in PC} &= V^2/R_p \text{ (where } R_p \text{ is the resistance of PC)} \\ &= 250^2/6000 \\ &= 10.42 \text{ W}\end{aligned}$$

The wattmeter will thus read total power = 3000 + 10.42 = 3010.42 W

$$\text{Hence, error in measurement} = \frac{10.42}{3000} \times 100\% = 0.35\%$$

- (c) **What is creep and how are creep adjustments made in a single-phase induction-type energy meter?**

Refer Section 8.3.3 in Chapter 8 on Measurement of Energy.

- (d) **What are the advantages of an instrument transformer?**

Refer Section 3.2 in Chapter 3 on Instrument Transformers.

- (e) **If ‘J’ is the inertia constant, ‘D’ is the damping constant and ‘K’ is the control constant of a D’Arsonval galvanometer, write down the condition for underdamped, critically damped and overdamped cases.**

Underdamped: $D^2 < 4 \text{ kJ}$

Critically damped: $D^2 = 4 \text{ kJ}$

Overdamped: $D^2 > 4 \text{ kJ}$

- (f) **A simple slide-wire is used for measurement of current in a circuit. The voltage drop across a standard resistor of 0.1 Ω is balanced at 75 cm. Find the magnitude of current if the standard cell emf of 1.45 V is balanced at 50 cm.**

Refer Example 5.3 in Chapter 5 on Potentiometers.

- (g) **Write down four applications of a dc potentiometer.**

Refer Section 5.4 in Chapter 5 on Potentiometers.

- (h) **Draw the circuit diagram of Owen’s bridge. What does it measure?**

Refer Section 6.4.5 in Chapter 6 on AC Bridges.

- (i) **Write down the expression for the gauge factor of a strain gauge in terms of Poisson’s ratio (μ).**

[Refer Equation (11.6) in Section 11.4 of Chapter 11 on Sensors and Transducers]

The gauge factor is defined as the ratio of per-unit change in resistance to per-unit change in length.

$$\text{Gauge factor } Gf = \frac{\Delta R/R}{\Delta L/L} = 1 + 2\mu + \frac{\Delta\rho/\rho}{\epsilon}$$

where $\epsilon = \frac{\Delta L}{L}$ = strain, ρ is the resistivity of the wire, and μ is the Poisson's ratio.

(j) What are the different forms of thermistors available? Draw them.

Thermistors are ceramic semiconductors and have either large positive temperature coefficient of resistance (PTC devices) or large negative temperature coefficient of resistance (NTC devices).

NTC Thermistors

- Bead type
 - Bare beads
 - Glass coated beads
 - Ruggedised beads
 - Miniature glass probes
 - Glass probes
 - Glass rods
 - Bead-in-glass enclosures
- Metallised surface-contact type
 - Disks
 - Chips (wafers)
 - Surface mounts
 - Flakes
 - Rods
 - Washers



Miniature glass probes

Figure 3



Bead in glass bulb

Figure 4



Disks

Figure 5

2. (a) What are the different forces acting on an indicating type of instrument? Discuss them.

(6)

Refer Section 2.4 in Chapter 2 on Analog Meters.

- (b) A weight of 5 g is used as the controlling weight in a gravity-controlled instrument. Find its distance from spindle if the deflecting torque corresponding to a deflection of 60° is 1.13×10^{-3} Nm.

(4)

For gravity control, the control torque is given by

$$T_c = Wl \sin \theta = mgl \sin \theta$$

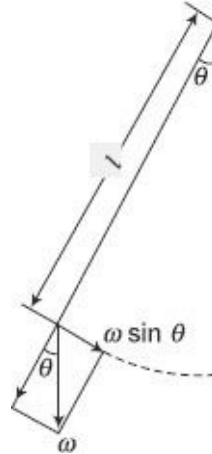

Thus, as per the given data, $1.13 \times 10^{-3} = 5 \times 10^{-3} \times 9.81 \times l \times \sin 60^\circ$

Hence, distance of weight from spindle $l = 26.6$ mm

3. Construct the different parts of an Electrodynamometer wattmeter and explain its theory for measurement of power. Discuss the shape of scale also.

(10)

Refer Sections 7.4.1, 7.4.2, and 7.4.3 in Chapter 7 on Power Measurement.

4. (a) Derive the steady-state deflection of a 'D'arsonval galvanometer. What are intrinsic constants of a galvanometer? Explain these.

(6)

Let,

l, d = dimensions of vertical and horizontal sides of the coil (m)

N = number of turns in the coil

B = air-gap flux density

I = moving-coil current

k = suspension spring constant

θ_F = final steady-state deflection of the galvanometer coil

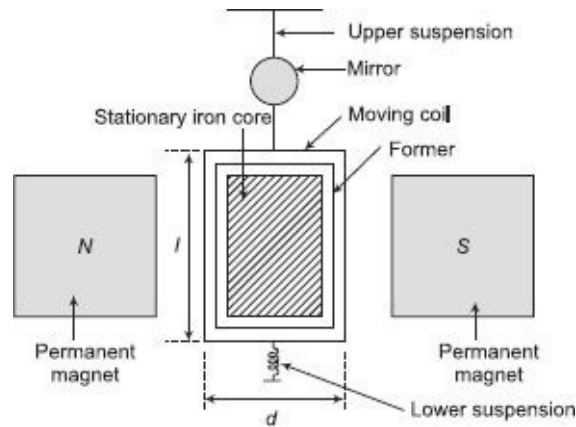

Figure 7

Force on each side of coil = $NBIl \sin \alpha$

where α is the angle between the conductor and the direction of magnetic field.

Since the magnetic field is radial (due to the stationary core), $\alpha = 90^\circ$

Hence, force on each side of coil = $NBIl$

Thus, deflecting torque $T_d = \text{Force} \times \text{Distance} = NBild$

$$= NBAI$$

where $A = ld = \text{area of coil}$

The quantities N , B , and A are constant for a given galvanometer.

Hence, deflecting torque $T_d = GI$

where $G = NBA = \text{Displacement constant of the galvanometer}$

The controlling torque is provided by the suspension. At a deflection of θ_F , the deflecting torque is given by $T_c = k\theta_F$

For final steady deflection, $T_d = T_c$

$$\text{or, } k\theta_F = GI$$

Hence, final steady deflection $\theta_F = GI/k$

The intrinsic constants of a D'Arsonval galvanometer are

1. **Displacement Constant:** The deflecting torque is given by $T_d = GI$, this G is called the displacement constant and it has a value $G = NBA$
2. **Inertia Constant:** While the moving system moves in the space between the two magnets, a retarding torque is produced due to inertia of the moving system. The value of this torque is given by $T_j = J (d^2\theta/dt^2)$; J is the moment of inertia of the moving system and θ is the deflection at time t . The moment of inertia J is also called the inertia constant.
3. **Damping Constant:** Damping torque is provided on the moving system either by air friction or by the action of eddy current. In either case, the damping torque is given by $T_D = D(d\theta/dt)$; this D is called damping constant.

4. **Control Constant:** The control torque provided by the suspension, that tends to control the movement of the moving system and also tries to restore the system to its initial position is given by $T_c = k\theta$; this k is called the control constant.

(b) **A D'arsonval galvanometer has the following data: Flux density = 8×10^{-3} , Wb/ m². Number of turns = 300, Length of coil = 15 mm. Width of coil = 30 mm, Spring constant = 2.5×10^{-3} Nm/rad. Calculate (a) the deflection of galvanometer for a current of 1 μ A, and (b) current sensitivity in mm/ μ A if the scale is kept 1 m away from the mirror.**

(4)

(i) Displacement constant = $G = NBl d = 300 \times 8 \times 10^{-3} \times 15 \times 10^{-3} \times 30 \times 10^{-3}$
 $= 1.08 \times 10^{-3}$ Nm/A

Deflection of galvanometer $\theta_F = GI/k = \frac{1.08 \times 10^{-3} \times 1 \times 10^{-6}}{2.5 \times 10^{-9}} = 0.432$ rad

(ii) Deflection in mm when the scale is kept at a distance of 1 mm from the mirror
 $= 2000 \theta_F = 864$ mm

Hence, current sensitivity $S = 864$ mm/ μ A

5. **Draw the equivalent circuit and phasor diagram of a current transformer. Derive the expression for ratio and phase angle error.**

(10)

Refer Sections 3.4, 3.4.1, 3.4.2, 3.5.1, and 3.5.2 in Chapter 3 on Instrument Transformers.

6. **Describe the working of Maxwell's inductance-capacitance bridge for measurement of inductance. Derive the equation for balance and draw the phasor diagram under balance condition. What are the advantages and disadvantages of this bridge circuit?**

(10)

Refer Section 6.4.1 in Chapter 6 on AC Bridges.

7. (a) **Explain the function of a time-base generator in a CRO.**

(5)

Refer Section 9.4 in Chapter 9 on Cathode Ray Oscilloscope.

(b) **Explain how voltage and current are measured with the help of CRO?**

(5)

Refer Section 9.7 in Chapter 9 on Cathode Ray Oscilloscope.

8. **Write short notes on any two of the following:**

(5 \times 2)

(a) **Electrical Resonance type Frequency Meter**

In an electrical resonance-type frequency meter, an unknown frequency is measured with the help of an R - L - C resonating circuit.

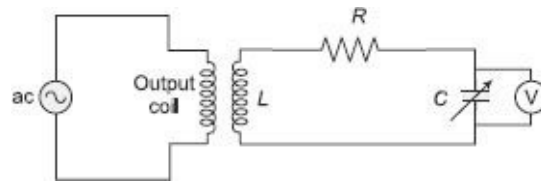

Figure 8

The unknown frequency ac source, whose frequency is to be measured is used as the voltage source in the driving circuit as shown in the figure. Voltage supply to the resonating circuit is given by coupling the coil L with the output coil of the signal ac source. Resonance in the RLC circuit is obtained by varying the capacitance. An electronic voltmeter connected across the capacitor is used as the primary detector for checking resonance condition in the RLC circuit. With certain value of R , L , and C , when resonance is obtained at the unknown frequency, the voltage indicated by the electronic voltmeter will be maximum. The unknown frequency can be calculated by using the mathematical condition for resonance in a series RLC circuit.

(b) Slide-wire dc Potentiometer

Refer Section 5.2 in Chapter 2 on Potentiometers.

(c) LVDT

Refer Section 11.3 in Chapter 11 on Sensors and Transducers.

Capacitive Transducer

(d) Refer Section 11.7.4 in Chapter 11 on Sensors and Transducers

SOLVED QUESTION PAPER-2

1. Attempt any *four* parts of the following:

(4 × 4 = 16)

- (a) **Define and explain briefly the static performance parameters of instruments.**
Refer Section 1.7 in Chapter 1 on Concepts of Measurement Systems.
- (b) **A source having an open circuit voltage of 20 V and an output impedance of $(1.5 + j4) \Omega$ is connected through a transmission network of impedance $(0.5 + j1)\Omega$. What should be the load impedance so that the maximum power will be delivered to it? Calculate the maximum deliverable power.**

For maximum power transfer, load impedance must be equal to the complex conjugate of Source impedance

Thus, load impedance = $(2 - j5)\Omega$

Maximum deliverable power = $20^2/(4 \times 2) = 50 \text{ W}$

- (c) **Derive the equations for capacitance and dissipation factor of a low-voltage Schering bridge. Draw the phasor diagram of the bridge under conditions of balance.**

Refer Section 6.5.2 in Chapter 6 on Schering Bridge.

- (d) **Explain the function and working of a Wagner earth Device.**

Refer Section 6.7 in Chapter 6 on Schering Bridge

- (e) **Describe the phenomenon of synchronization of vertical input signal-to-sweep generator in CRO.**

Refer Section 9.5 in Chapter 9 on Cathode Ray Oscilloscope.

- (f) **Discuss delay sweep in CRO.**

When short-duration pulses are displayed in the CRO, proper synchronisation is achieved by internal triggering in the ac trigger mode. However, due to the finite delay of the trigger amplifiers used internally, the initial build-up of the pulse may not be observable in the display. To avoid this, a delay line producing a typical delay in the range of 100 ns to 1 ms is often incorporated in the Y amplifier.

The “delayed sweep” is an additional facility available in some oscilloscopes, enabling enhanced resolution in time measurements. The “delaying sweep” allows the operator to select any specific delay time by means of a 10-turn calibrated dial. This delay is generated by applying a sweep ramp to a voltage comparator that produces a trigger pulse at a later point in time. The delayed sweep starts at the selected time, and is usually a decade or two faster than the delaying sweep. Using a very high speed for the delayed sweep, considerable magnification is achieved so that short duration phenomena occurring after a delay period following a trigger can be conveniently observed.

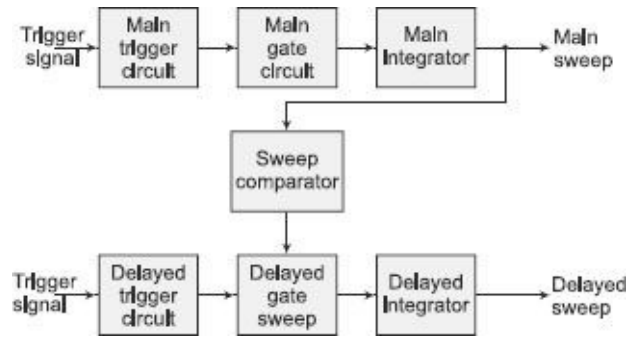

Figure 1

2. Attempt any *four* parts of the following:

(4 × 4 = 16)

(a) Write a technical note on loading effects of instruments

Refer Section 1.9 in Chapter 1 on Concepts of Measurement Systems.

(b) Explain with the help of a block diagram, the various parts of an electronic multimeter.

Refer Section 10.4 in Chapter 10 on Electronic Instruments.

(c) Describe the methods of measurement of voltage and power a radio frequencies.

Refer Section 17.7 in Chapter 17 on Microwave and RF Measurement.

(d) What are the various factors taken into consideration while selecting an electronic type analog voltmeter.

Refer Section 10.3 in Chapter 10 on Electronic Instruments.

(e) A sawtooth voltage has a peak value of 40 V and a time period of 5.0 seconds as shown in Figure 2.

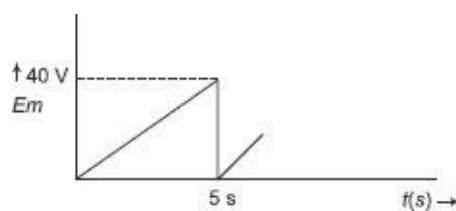

Figure 2

Calculate the error when measuring this voltage with an average reading voltmeter, calibrated in terms of rms value of sinusoidal waves.

$$\text{Error} = (\text{True value} - \text{Actual value})/\text{Actual value} = \frac{\frac{40}{\sqrt{3}} - \frac{40}{2} \times 1.11}{\frac{40}{2} \times 1.11} = \frac{23.1 - 22.2}{22.2} = 4.05\%$$

(f) Describe the circuit diagram and operation of a dc voltmeter using a direct coupled amplifier.

dc voltmeter using direct coupled amplifier

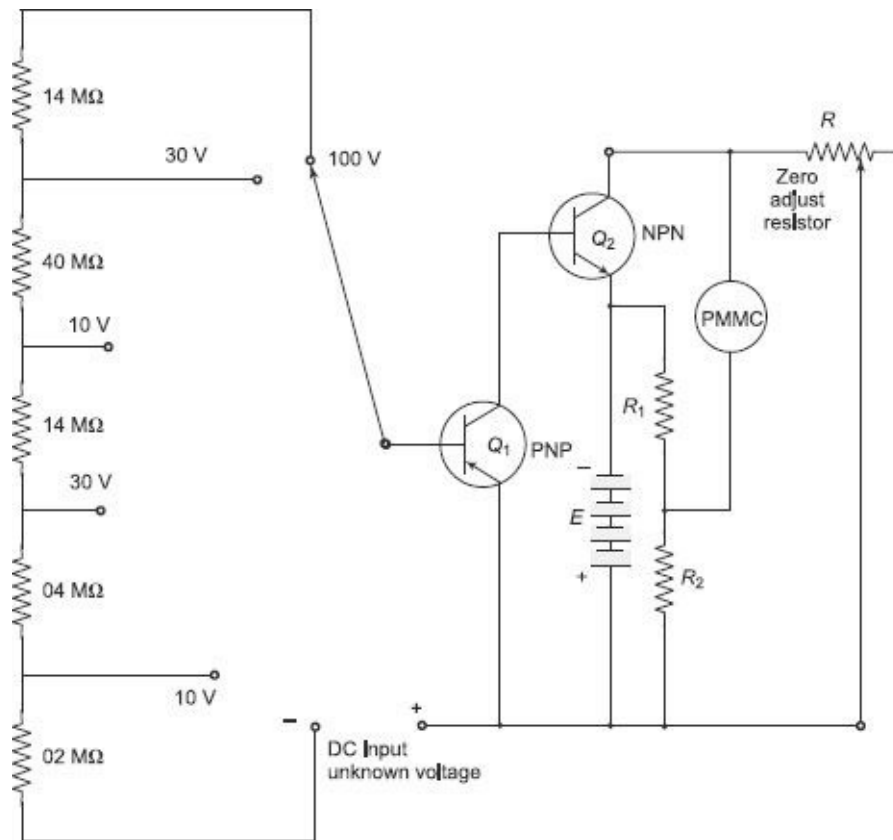

Figure 3 *Direct coupled amplifier DC voltmeter using cascade transistor*

This type of voltmeter is very common because of its low cost. This instrument can be used only to measure voltages of the order of millivolts owing to limited amplifier gain. The circuit diagram for a direct coupled amplifier dc voltmeter using cascaded transistors is shown in Figure 3. An attenuator is used in input stage to select voltage range. A transistor is a current-controlled device; so resistance is inserted in series with the transistor Q_1 to select the voltage range. It can be seen from the figure that sensitivity of the voltmeter is 200 kilohms/volt, neglecting the small resistance offered by the transistor Q_1 . Other values of range-selecting resistors are also so chosen that sensitivity remains the same for all ranges. So current drawn from the circuit is only 5 microamperes.

Two transistors in cascaded connections are used instead of a single transistor for amplification in order to keep the sensitivity of the circuit high. Transistors Q_1 and Q_2 are taken complementary to each other and are directly coupled to minimise the number of components in the circuit. They form a direct coupled amplifier. A variable resistance R is put in the circuit for zero adjustment of the PMMC. It controls the bucking current from the supply E to buck out the quiescent current. The drawback of such a voltmeter is that it has to work under specified ambient temperature to get the required accuracy; otherwise excessive drift problem occurs during operation.

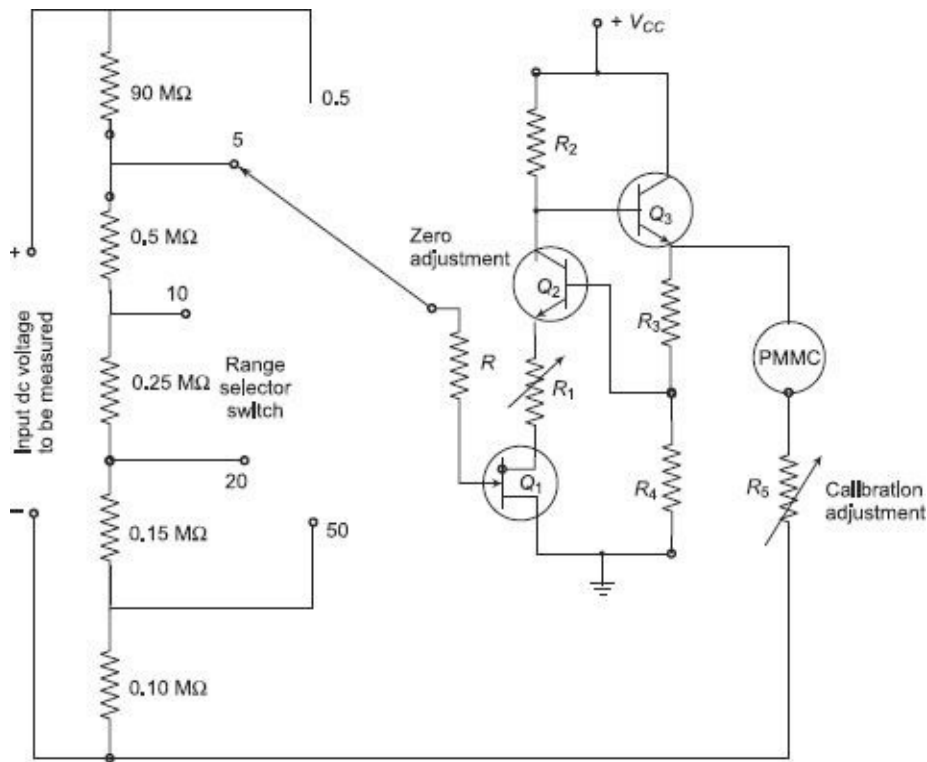

Figure 4 Direct coupled amplifier transistorised dc voltmeter using FET

DC Voltmeter using FET

Another circuit diagram of a direct coupled amplifier dc voltmeter using FET in input stage is shown in Figure 4. In this voltmeter, the voltage to be measured is first attenuated with the range selector switch to keep the input voltage of the amplifier within its level. A FET is used in the input stage of amplifier because of its high input impedance so that it does not load the circuit of which the voltage is to be measured and it also keeps the sensitivity of the voltmeter very high. As the FET is a voltage controlled device, so the resistance network of attenuator is put in shunt in the circuit. Transistors Q_2 and Q_3 form the direct coupled dc amplifier whose output is finally supplied to the PMMC meter. When transistors work within their dynamic region, the deflection of the meter remains proportional to the applied input voltage. This voltmeter can be used for measurement of voltages of the order of millivolts because of sufficient gain of the amplifier.

Apart from the high input impedance, this circuit has another advantage that when input voltage exceeds its limit, the amplifier gets saturated which limits the current passing through the PMMC meter. So the meter does not burn out.

3. Attempt any two parts of the following:

(4.5 × 2 = 9)

- (a) Describe the working of an inter-modulation distortion meter with the help of a block diagram.

Refer Section 13.17 in Chapter 13 on Signal Generators and Analysers.

- (b) What are different types of distortions caused by amplifiers?

Frequency distortion, phase distortion, amplitude distortion, intermodulation distortion, crossover distortion, total harmonic distortion.

(c) Describe the basic circuit of a spectrum analyser.

Refer Section 13.18 in Chapter 13 on Signal Generators and Analysers.

4. Attempt any two parts of the following:

(4.5 × 2 = 9)

(a) Explain frequency measurement using Schmitt trigger with the help of a diagram.

Refer Section 10.5 in Chapter 10 on Electronic Instruments.

(b) Sketch the block diagram for time-interval measurement mode of operation using DDAs and DCAs.

Readers can refer to reference material.

(c) Explain the operation of digital phase meters with the help of block diagram.

Readers can refer to reference material.

SOLVED QUESTION PAPER-3

1. (a) Compare between spring and gravity-control methods.

Refer Section 2.5.2 in Chapter 2 on Analog Meters.

(b) The deflecting torque of an ammeter varies as the square of the current passing through it. If a current of 5 A produces a deflection of 90 degrees, what will be the deflection for a current of 10 A when the instrument is

i. Spring controlled?

ii. Gravity controlled?

(8 + 8)

Deflecting torque varies as the square of the current, thus $T_d = K_d I^2$

(i) For spring control, the controlling torque (T_C) is related to the angle of deflection (θ) by the relation $T_C = k\theta$

Under steady deflection condition, $T_d = T_C$

$$K_d I^2 = k\theta$$

$$\theta = (K_d/k)I^2 = K_1 I^2$$

Given that the deflection is 90° when the current is 5 A.

Thus, $90 = K_1 \cdot 5^2$

$$K_1 = 3.6$$

Hence, for a current of 10 A, the deflection is $\theta = K_1 I^2 = 3.6 \times 10^2 = 360^\circ$

(ii) For gravity control, the controlling torque (T_C) is related to the angle of deflection (θ) by the

relation $T_C = k_g \cdot \sin \theta$

Under steady deflection condition, $T_d = T_C$

$$K_d I^2 = k_g \cdot \sin \theta$$

$$\theta = \sin^{-1}[(K_d/k_g)I^2] = \sin^{-1}[K_2 I^2]$$

Given that the deflection is 90° when the current is 5 A.

Thus, $90 = \sin^{-1}[K_2 \cdot 5^2]$

$$K_2 = 1/25$$

Hence, for a current of 10 A, the deflection is

$$\theta = K_2 I^2 = \sin^{-1}[(1/25) \times 10^2] = \sin^{-1}[4]$$

[Note: There is a mathematical error in this question]

2. (a) **Draw and explain the equivalent circuit and phasor diagram of a current transformer.**

Refer Section 3.4 in Chapter 3 on Instrument Transformers.

- (b) **A 1000/5 A current transformer, bar primary type, has the loss component of exciting current equal to 0.7% of the primary current. Find the ratio error**
- When turn ratio is equal to nominal ratio**
 - When the secondary turn is reduced by 0.5%**

(8+8)

$$\text{For a CT, Percentage ratio error} = \frac{\text{Nominal ratio} - \text{Actual ratio}}{\text{Actual ratio}} \times 100\%$$

Given, nominal ratio $n = 1000/5 = 20$

- (i) When turns ratio (T) is equal to the nominal ratio (n),

$$T = n$$

When the loss component of exciting current primary current, and secondary current are represented by I_C , I_P , and I_S respectively, then

$$\text{Actual ratio} = R = n + \frac{I_C}{I_S} = n + \frac{I_C}{I_P/T} = \frac{I_C}{I_P/n} = n + n \cdot \frac{I_C}{I_P} = 20 + 20 \times \frac{0.7}{100} = 20.14$$

$$\text{Hence, percentage ratio error} = \frac{n - R}{R} \times 100\% = \frac{20 - 20.14}{20.14} \times 100\% = 0.695\%$$

- (ii) When secondary turns is reduced by 0.5% then the new modified turns ratio is given by $T_1 = 0.995 \times n$

$$\begin{aligned} \text{Actual ratio} &= R = n + \frac{I_C}{I_S} = n + \frac{I_C}{I_P/T_1} = \frac{I_C}{I_P/0.995 \times n} \\ &= n + 0.995 \times n \times \frac{I_C}{I_P} = 20 + 0.995 \times 20 \times \frac{0.7}{100} = 20.1393 \end{aligned}$$

$$\text{Hence, percentage ratio error} = \frac{n - R}{R} \times 100\% = \frac{20 - 20.1393}{20.1393} \times 100\% = 0.692\%$$

3. (a) **With a neat figure, explain the construction and working principle of an electrical resonance frequency meter.**

In an electrical resonance-type frequency meter, an unknown frequency is measured with the help of an R - L - C resonating circuit.

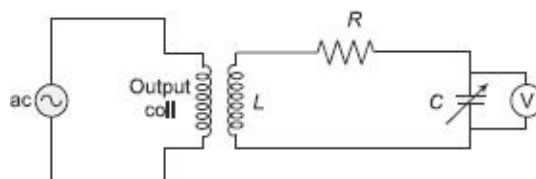

Figure 1

The unknown frequency ac source, whose frequency is to be measured is used as

the voltage source in the driving circuit as shown in Figure 1. Voltage supply to the resonating circuit is given by coupling the coil L with the output coil of the signal ac source. Resonance in the RLC circuit is obtained by varying the capacitance. An electronic voltmeter connected across the capacitor is used as the primary detector for checking resonance condition in the RLC circuit. With certain values of R , L , and C , when resonance is obtained at the unknown frequency, the voltage indicated by the electronic voltmeter will be maximum. The unknown frequency can be calculated by using the mathematical condition for resonance in a series RLC circuit.

- (b) Explain the working of a single-phase dynamometer-type power-factor meter. (8 + 8)

Single-phase dynamometer-type power factor meter is schematically shown in Figure 2.

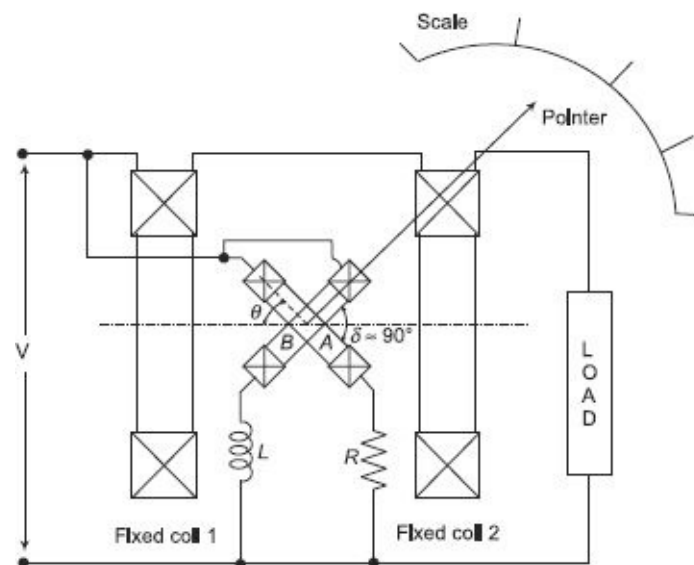

Figure 2

It has two fixed coils that are connected in series with the load and thus act as the current coils. Current coils, thus, carry the same current as the load. Two identical coils A and B that are connected to the spindle and placed in the space between the two fixed coils are the moving coils. Coil A has a high value non-inductive resistance R connected with it and the coil B has a highly inductive choke coil L connected to it. Both the coils along with their respective series connected R and L are connected parallel to the supply, and are called the pressure coils, since current through these two coils, A and B are proportional to the supply voltage. Values of R and L are so selected that at normal frequency, their impedances become equal ($R = \omega L$) and hence the two coils, A and B carry the same current. Coil A being highly resistive, its current is almost in phase with the supply voltage V . Similarly, the coil B being highly inductive, its current is almost at an angle $\delta \approx 90^\circ$ with the supply voltage V . The axes of the coils A and B are also kept at the same angle $\delta \approx 90^\circ$ with respect to each other.

There will be two deflecting torques, one acting on the coil A and the other on B . These two coil windings are so arranged that they experience torque in the opposite direction. The pointer which is attached to these two coils jointly, will

thus attain a steady deflection when these two opposite torques on coils A and B are equal. Let us consider a lagging power factor $\cos \phi$ of the load.

Deflecting torque on the coil A, $T_A = KVI \frac{dM}{d\theta} \cos \phi \sin \theta$

where θ = angular deflection from the reference horizontal plane

M = mutual inductance between the fixed coils and coil A

Deflecting torque on the coil B

$$T_B = KVI \frac{dM}{d\theta} \cos(90^\circ - \phi) \sin(90^\circ + \theta) = KVI \frac{dM}{d\theta} \sin \phi \cos \theta$$

At equilibrium, $T_A = T_B$

$$KVI \frac{dM}{d\theta} \cos \phi \sin \theta = KVI \frac{dM}{d\theta} \sin \phi \cos \theta$$

or, $\theta = \phi$

Therefore, the deflection (θ) of the instrument is a measure of the power-factor angle. By proper calibration, the scale can be made to show the value of the power factor directly.

4. (a) What is energy-meter testing? Explain phantom load testing.

Refer Sections 8.4, and 8.4.1 in Chapter 8 on Measurement of Energy.

(b) A 220, 5 A, dc energy meter is tested at its marked ratings. The resistance of the pressure circuit is 8800 ohms and that of the current coil is 0.1 ohm. Calculate the power consumed when testing the meter with phantom loading with a current circuit excited by a 6-volt battery.

(8 + 8)

Follow the procedure similar to Example 8.5 in Chapter 8 on Energy Meters.

5. A current of 10 A, at a frequency of 50 Hz, was passed through the primary of a mutual inductor having a negligible phase defect, the voltage of primary and secondary terminals were measured on a co-ordinate potentiometer and are given below:

With secondary open circuited; secondary voltage $I_q = -2.72 + j1.57$ volts.

Primary voltage = $-0.211 + j0.352$ volts.

With secondary short-circuited: primary voltage = $-0.051 + j0.329$ volts.

The phase primary current relative to the potentiometer current was same in both the tests. Determine the resistances and self-inductances of the two windings. Find also the mutual inductance.

(16)

The voltage equations in the phasor form can be written as

$$E_1 = I_1 (R_1 + jX_1) + I_2 (jX_m) \qquad E_2 = I_2 (R_2 + jX_2) + I_1 (jX_m)$$

where

E_1 = Voltage of primary winding,

E_2 = Voltage of secondary winding,

I_1 = Current of primary winding,

I_2 = Current of secondary winding,

R_1 = Resistance of primary winding,

R_2 = Resistance of secondary winding,

X_1 = Self-reactance of primary winding,

X_2 = Self-reactance of secondary winding,

and X_m = Mutual reactance.

Under open-circuit conditions: $I_2 = 0 \therefore E_2 = I_1 (jX_m)$.

Let $I_1 = I_p + jI_q$ where I_p and I_q are the phase and quadrature components of I_1 .

Therefore, we can write $E_2 = (I_p + jI_q)(jX_m) = (-I_q + jI_p) X_m$

From the data given, we have $-2.72 + j1.57 = -I_q X + jI_p X$

or $I_p X_m = 1.57 \text{ V}$ and $I_q X_m = 272 \text{ V}$

or $X_m \sqrt{I_p^2 + I_q^2} = 3.14 \text{ V}$.

but $\sqrt{I_p^2 + I_q^2} = I = 10 \text{ A}$. $\therefore X_m = \frac{3.14}{10} = 0.314 \Omega$.

Hence, mutual inductance $M = \frac{X_m}{2\pi f} = \frac{0.314}{2\pi \times 50} \text{ H} = 1.0 \text{ mH}$

$I_p = \frac{1.57}{0.314} = 5.0 \text{ A}$ and $I_q = \frac{2.72}{0.314} = 8.66 \text{ A}$.

At open circuit, $E_1 = I_1(R_1 + jX_1) = j(I_p + jI_q)(R_1 + jX_1)$

$$= (I_p R_1 - I_q X_1) + j(I_p X_1 + I_q R_1).$$

Putting the numerical values, we get $-0.211 + j0.352 = (5R_1 - 8.66X_1) + j(5X_1 + 8.66R_1)$.

Equating real and the imaginary terms, we have $5R_1 - 8.66 X_1 = -0.211$

(i)

and $5X_1 + 8.66 R_1 = 0.352$

(ii)

Solving (i) and (ii), we get $R_1 = 0.02 \Omega$, and $X_1 = 0.0359 \Omega$.

\therefore Self-inductance of primary winding $L_1 = \frac{0.0359}{2\pi \times 50} \text{ H} = 0.114 \text{ H}$

At short circuit of secondary winding $E_2 = 0$,

$$\therefore E_2 - I_2 (R_2 + jX_2) + I_1(jX_m) = 0$$

or $I_2 = -\frac{jX_m}{R_2 + jX_2} I_1$.

Thus, $E_1 = I_1(R_1 + jX_1) + I_2(jX_m)$
 $= I_1(R_1 + jX_1) + I_1 \frac{X_m^2}{R_2 + jX_2}$

Now at short circuit, $E_1 = 0.051 + j0.329$

Also, $I_1(R_1 + jX_1) = -0.211 + j0.352$

$$-0.051 + j0.329 = -0.211 + j0.352 + \frac{(5 + j8.66) \times (0.314)^2}{R_2 + jX_2}$$

or $R_2 + jX_2 = \frac{0.494 + j0.856}{0.16 - j0.023} = 2.27 + j5.66 \Omega$

$\therefore X_2 = 5.66 \Omega$

Self-reactance of secondary winding $L_2 = \frac{5.66}{2\pi \times 50} \text{ H} = 18 \text{ mH}$.

Resistance of secondary winding $R_2 = 2.27 \text{ W}$.

6. (a) Describe any one method of measuring a very high value of resistance.

Refer Section 4.4.4 in Chapter 4 on Measurement of Resistance

- (b) A Lissajous pattern on the oscilloscope is stationary and has 6 vertical maximum values and 5 horizontal maximum values. The frequency of horizontal input is 1500 Hz.

Determine the frequency of vertical input.

(8 + 8)

In a Lissajous pattern on an oscilloscope,

$$\frac{f_v}{f_h} = \frac{\text{Number of vertical peaks}}{\text{Number of horizontal peaks}}$$

where f_v and f_h are frequencies of the signals applied in vertical and horizontal plates respectively.

Given, $f_h = 1500 \text{ Hz}$

Thus, frequency of vertical input

$$f_v = f_h \times \frac{\text{Number of vertical peaks}}{\text{Number of horizontal peaks}} = 1500 \times \frac{6}{5} = 1800 \text{ Hz}$$

7. Describe how an unknown capacitance can be measured with the help of D'Sauty's bridge. What are the limitations of the bridge and how are they overcome by using a modified form of D'Sauty's bridge.

(16)

Refer Section 6.5.1 in Chapter 6 on AC bridges.

8. (a) Explain the double-bar method of measuring the flux density of an iron specimen.

Refer Section 12.11.2 in Chapter 12 on Magnetic Measurements.

- (b) A solenoid is 60 cm long and 2.5 cm in diameter. It is uniformly wound with 600 turns of wire. Find the magnetic field strength at the centre of the solenoid when carrying a current of 2 A. If the secondary coil is wound round the central part of the solenoid, calculate the flux passing through it.

(8 + 8)

For the given solenoid as shown in Figure 3.

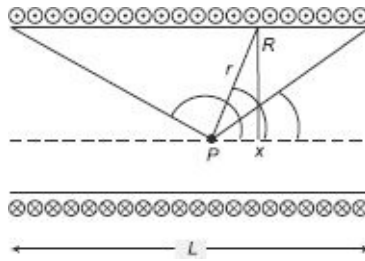

Figure 3

The magnetic field strength at any point x on the central axis of the solenoid is given by

$$H = \frac{NI}{2L} (\cos \theta_1 - \cos \theta_2)$$

Given

$$L = 60 \text{ cm} = 0.6 \text{ m}$$

$$R = 2.5/2 = 1.25 \text{ cm} = 0.0125 \text{ m}$$

$$N = 600$$

$$I = 2 \text{ A}$$

$$\cos \theta_1 = \frac{0.3}{\sqrt{0.3^2 + 0.0125^2}} = 0.999$$

$$\text{Similarly, } \cos \theta_2 = \cos \left(180^\circ - \tan^{-1} \frac{0.0125}{0.3} \right) = -0.999$$

$$\text{Thus, } H = \frac{600 \times 2}{2 \times 0.6} (0.999 + 0.999) = 1998 \text{ AT/m}$$

$$\text{Flux density } B = \mu_0 \times H = 4\pi \times 10^{-7} \times 1998 = 2.51 \text{ mWb/m}^2$$

Hence, flux passing through the central part of the solenoid is given by

$$\phi = B \times A = 2.51 \times 4\pi (0.0125)^2 = 4.93 \text{ mWb}$$

SOLVED QUESTION PAPER-4

PART A (10 × 2 = 20)

1. **A set of independent current measurements were recorded as 10.03, 10.10, 10.11 and 10.08 A. Calculate the range of an error.**

$$\text{Range of error} = I_{\max} - I_{\min} = 10.11 - 10.03 = 0.08 \text{ A}$$

2. **How is the international standard of length defined?**

The metre (or meter), is the fundamental unit of length in the International System of Units (SI). Originally intended to be one ten-millionth of the distance from the earth's equator to the North Pole (at sea level), its definition has been periodically refined to reflect growing knowledge of metrology. Since 1983, it has been defined as "the length of the path travelled by light in vacuum during a time interval of $1/299,792,458$ of a second."

3. **Compare and contrast analog and digital storage oscilloscope.**

Refer Section 9.11 in Chapter 9 on Cathode Ray Oscilloscope.

4. **Distributed capacitance of a coil is measured by changing the capacitance of the tuning capacitor. The values of the tuning capacitors are C_1 and C_2 for the resonant frequencies f_1 and $2f_1$. What is the value of the distributed capacitance?**

Reader may refer to reference materials

5. **In a sweep frequency generator, two oscillators, one with frequency range of 3 GHz to 5 GHz is heterodyned with a second oscillators having a fixed frequency output of 3 GHz. How does the output frequency vary?**

Output frequency varies between 0 to 8 GHz.

6. **What is intermodulation distortion?**

Intermodulation distortion results when two different frequencies are simultaneously passed through an amplifier (or other audio component). Two new frequencies are created from the sum and difference of the original frequencies. If a 100 Hz and 150 Hz tone are passed through an amplifier, the sum of the original frequencies ($150 + 100 = 250$ Hz) and the difference ($150 - 100 = 50$ Hz) will be generated, resulting in intermodulation distortion. IM distortion is measured as a percentage of the original frequencies and a lower specification is better.

7. **Why is a Schmitt trigger used in a digital frequency meter?**

Schmitt trigger is used in a digital frequency meter to convert the input signal (whose frequency is to be measured) to a square-wave signal of same frequency. This square-wave signal is TTL compatible and can be used directly as one input to the count gate.

8. **Draw the block diagram of integrating type DVM.**

Refer Section 10.6.3 in Chapter 10 on Electronic Instruments.

9. List the elements of a digital data acquisition system.

The basic elements of a data acquisition system are as follows:

- (a) Sensors and transducers
- (b) Field wiring
- (c) Signal conditioning
- (d) Data acquisition hardware
- (e) PC (operating system)
- (f) Data acquisition software

10. What is the need for data loggers?

Refer Section 15.3.1 in Chapter 15 on Recording, Storage and Display Devices.

PART B (5 × 16 = 80)

11. (a) (i) How can you convert the PMMC meter into a voltmeter and ammeter? How can you extend the range of these meters?

(8)

Refer Section 2.7 in Chapter 2 on Analog Meters.

(ii) Explain the types of errors with an example?

(8)

Refer Section 1.8.1 in Chapter 1 on Concepts of Measurement Systems.

OR

(b) (i) What are the conditions for bridge balance?

(8)

Refer to Section 6.3 in Chapter 6 on AC Bridges.

(ii) How can you measure the unknown inductance using Maxwell's LC Bridge? Draw the phasor diagram also.

(8)

Refer to Section 6.4.2 in Chapter 6 on AC Bridges.

12. (a) (i) Draw the block diagram of a sampling oscilloscope. How does the sampling oscilloscope increase the apparent frequency response of an oscilloscope?

(8)

Refer Section 9.10 in Chapter 9 on Cathode Ray Oscilloscope

(ii) How can you measure large capacitors and small coils using Q-meters?

(8)

Reader may refer to reference materials

OR

(b) (i) Explain the vector impedance meter with a neat block diagram.

(8)

Reader may refer to reference materials

(ii) How can you measure the RF voltage and power using RF millivoltmeter?

(8)

Refer Section 17.7 in Chapter 17 on Microwave and RF Measurement.

13. (a) (i) Draw the block diagram of the frequency divider type of signal generator with frequency modulation and explain.

(8)

Refer Section 13.14 in Chapter 13 on Signal Generators and Analysers.

(ii) What are the basic elements of a function generator? Explain how to generate the square wave, triangular wave and sine wave using function generator.

(8)

Refer Section 13.13 in Chapter 13 on Signal Generators and Analysers.

OR

(b) (i) Explain the working of frequency-selective wave analyzer with a neat block diagram.

(8)

Refer Section 13.16 in Chapter 13 on Signal Generators and Analysers.

(ii) How is the fundamental frequency suppressed using the fundamental suppression distortion analyser.

(8)

Refer Section 13.17 in Chapter 13 on Signal Generators and Analysers.

14. (a) (i) Draw the block diagram of a multiplexed display used in a frequency counter and explain.

(8)

(ii) Explain how can you extend the frequency range of the counter.

(8)

OR

(b) (i) How can you make automatic polarity indication and automatic ranging in a digital instrument?

(8)

(ii) Explain the need for virtual instrument with an example.

(8)

Reader may refer to reference materials.

15. (a) (i) Draw the schematic of an isolation amplifier and explain the need for an isolation amplifier in interfacing transducers.

(8)

(ii) With neat diagrams explain digital to analog multiplexing.

(8)

Reader may refer to reference materials.

OR

(b) (i) Explain the IEEE 488 electrical interface system.

(8)

Refer Section 14.7 in Chapter 14 on Data Acquisition Systems.

(ii) How can you measure the power using optical instrument? Draw the auto-ranging power meter and explain.

(8)

Refer Section 18.4 in Chapter 18 on Fibre Optic Measurements.

SOLVED QUESTION PAPER-5

PART-A (10 × 2 = 20)

1. Answer the following

(a) Sketch a simple diagram of an electronic dc voltmeter.

Refer Section 10.6 in Chapter 10 on Electronic Instruments.

(b) Enumerate application of CRO for measurement of electrical quantities.

Refer Section 9.7 in Chapter 9 on Cathode Ray Oscilloscope.

(c) How many cycles of a 6 kHz sinusoidal signal appear on the CRO screen if the sweep frequency is 3 kHz?

Two cycles.

(d) For what measurement is an LCR meter used?

Self-inductance, capacitance, loss tangent, resistance.

(e) A wave analyser is used for what type of analysis?

A wave analyser is an instrument designed to measure relative amplitude of single frequency components in a complex waveform. Basically, the instrument acts as a frequency-selective voltmeter which is turned to the frequency of one signal while rejecting all other signal components. The desired frequency is selected by a frequency-calibrated dial to the point of maximum amplitude. The amplitude is indicated either by a suitable voltmeter or a CRO.

(f) For what applications can CT and PT be used?

Reducing high current and voltage to smaller values measurable with easily available low-range ammeters and voltmeters.

(g) Define a transducer and distinguish between active and passive transducers.

A transducer is a device, usually electrical, electronic, electro-mechanical, electromagnetic, photonic, or photovoltaic that converts one type of energy or physical attribute to another (generally electrical or mechanical) for various measurement purposes including measurement or information transfer (for example, pressure sensors). An active transducer is a transducer whose output is dependent upon sources of power, apart from that supplied by any of the actuating signals, which power is controlled by one or more of these signals. Passive transducers are those which do not need an external source. Passive transducers directly produce electric signals without an external energy source.

(h) What are necessities of recorders?

After collecting information about the state of some process, the next consideration is how to present it in a form where it can be readily used and analysed. There are techniques available to either display measurement data for current use or record it for future use. Following this, standards of good practice

for presenting data in either graphical or tabular form are available, using either paper or a computer monitor screen as the display medium.

(i) How are LDC displays advantageous over LED displays?

Summarise Sections 15.4.2. and 15.4.3 in Chapter 15 on Recording, Storage and Display Devices.

(j) List various types of telemetry systems.

Readers can refer to reference material.

PART- B (4 × 5 = 20)

2. With the help of the circuit diagram of an electronic multimeter, list the essential elements of the meter and discuss its principle of working.

(10)

Refer Section 10.4 in Chapter 10 on Electronic Instruments.

3. Why is a CRO considered very useful instrument? With the aid of a block diagram representation, discuss working of a CRO. How is it used for easurement of phase angle of a wave?

(10)

Refer Sections 9.2 and 9.9 in Chapter 9 on Cathode Ray Oscilloscope.

4. Describe a harmonic distortion analyser with the help of a block diagram. How does a commercial harmonic distortion analyzer differ from the ideal one?

Refer Section 13.17 in Chapter 13 on Signal Generators and Analysers.

5. Discuss working of a strain gauge and derive expression for the “gauge factor (G)”. Why is the factor about 2 for most of the metallic straingauges? A strain gauge has a resistance of 100 Ω and the gauge factor of 2.1, of strain is 2×10^{-3} . Obtain the change in resistance.

Refer Section 11.4.1 in Chapter 11 on Sensors and Transducers.

$$\text{Gauge factor} = \frac{\Delta R/R}{\text{Strain}}$$

Given, $R = 100 \Omega$, gauge factor = 2.1 and strain = 2×10^{-3}

Thus, change in resistance $\Delta R = \text{Gauge factor} \times R \times \text{Strain} = 2.1 \times 100 \times 2 \times 10^{-3} = 0.42 \Omega$

6. Describe the working principle of a digital tape recorder. What are its areas of applications?

Refer Section 15.3.2 in Chapter 15 on Recording, Storage and Display Devices

PART-C (2 × 10 = 20)

7. (a) Explain the principle of working and operation of a Current Transformer (CT) and derive expressions for the ratio and phase-angle errors.

(2 × 10)

Refer Sections 3.3, 3.4, and 3.5 in Chapter 3 on Instrument Transformers.

- (b) A 1000/5, 50 Hz bar primary-type current transformer has secondary burden of 1.5 Ω (non-inductive). Calculate the flux in the core and the ratio error at rated condition of the CT. Assume iron loss in the core to be 1.5 watts. Neglect leakage flux and the magnetizing current.**

Follow Example 3.3 in Chapter 3 on Instrument Transformers.

- 8. (a) What is telemetry and what are its basic components? Sketch the block-diagram representation of a typical telemetry system and explain the method of data transmission.**
- (b) List types of telemetry systems and distinguish between dc and ac telemetry systems.**

(10)

Readers can refer to reference material.

9. Write short notes on

- (a) Applications of Telemetry systems**

Readers can refer to reference material

- (b) Spectrum analysis and**

Refer Section 13.18 in Chapter 13 on Signal Generators and Analysers.

- (c) Special-purpose oscilloscope**

Summarise sections 9.10, 9.11 and 9.12 in Chapter 9 on Cathode Ray Oscilloscope.

SOLVED QUESTION PAPER-6

PART A

1. (a) Explain in detail the classification of measuring instruments.

(8)

Refer Section 1.6 in Chapter 1 on Concepts of Measurement Systems.

- (b) With a neat sketch, describe the construction and working of PMMC instrument. Derive the torque equation for this instrument. Comment on shape of scale.

(10)

Refer Sections 2.6 and 2.6.1 in Chapter 2 on Analog Meters.

2. (a) Which three forces are required for satisfactory operation of an analog indicating instrument? State the function of each force.

(6)

Refer Section 2.4 in Chapter 2 on Analog Meters.

- (b) What are shunts and multipliers? What are the disadvantages of a shunt?

Refer Sections 2.7.1 and 2.7.2 in Chapter 2 on Analog Meters.

Disadvantages of shunt—Refer Section 3.2 in Chapter 3 on Instrument Transformers.

- (c) The inductance of a moving-iron ammeter is given by the expression $L = (12 + 5\theta - 2\theta^2) \mu\text{H}$, where θ is the angular deflection in radians from zero position. Determine

(i) the spring constant

(ii) the angular deflection in radians for a current of 10 A, if the deflection for a current of 5 A is 30°

(6)

Follow Example 2.11 in Chapter 2 on Analog Meters.

3. (a) Draw the circuit diagram of Kelvin's double bridge. Derive the expression for unknown resistance with usual notations.

(8)

Refer Section 4.3.2 in Chapter 4 on Measurement of Resistance.

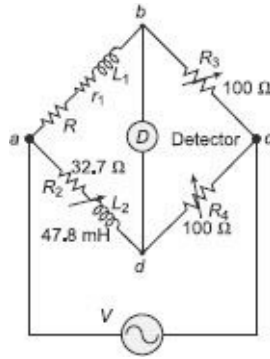

Figure 1

- (b) In a Maxwell's inductance comparison bridge, the arm ab consists of a coil with inductance L_1 and resistance r_1 in series with a non-inductive resistance R . Arm bc and cd are each a non-inductive resistance of 100Ω . Arm ad consists of standard variable inductor L of 32.7Ω resistance. Balance is obtained when $L_2 = 47.8 \text{ mH}$ and $R = 1.36 \Omega$. Find the resistance and inductance of the coil in the arm ab .

(4)

Refer Section 6.4.1 in Chapter 6 on ac Bridges and then do the following:

- (c) The four impedances of an bridge are $Z_1 = 400 \Omega \angle 50^\circ$, $Z_2 = 200 \Omega \angle 30^\circ$, $Z_3 = 800 \Omega \angle -50^\circ$, $Z_4 = 400 \Omega \angle -40^\circ$. Find out whether the bridge is balanced under these conditions.

$$L_1 = L_2 \times \frac{R_3}{R_4} = 47.8 \times \frac{100}{100} = 47.8 \text{ mH}$$

$$(r_1 + R) = R_2 \times \frac{R_3}{R_4} = 32.7 \times \frac{100}{100} = 32.7 \Omega$$

Given $R = 1.36 \Omega$

Hence, $r_1 = 32.7 - 1.36 = 31.34 \Omega$

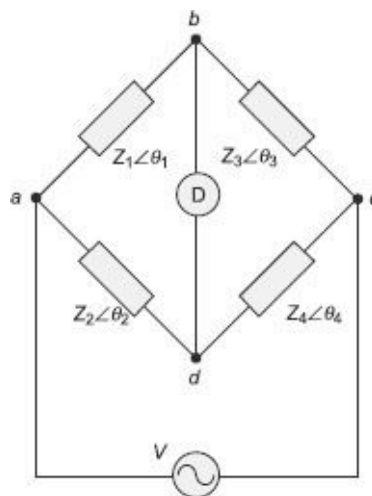

Figure 2

For the bridge to be balanced, we need to satisfy two conditions (refer Section 6.3 in Chapter 6 on ac bridges).

In magnitude only, $Z_1 Z_4 = Z_2 Z_3$

We see that $Z_1 Z_4 = 400 \times 400 = 1600$

And $Z_2 Z_3 = 200 \times 800 = 1600$

Thus, a magnitude criterion for balance is met.

In phase angle, we need to have $\angle(\theta_1 + \theta_4) = \angle(\theta_2 + \theta_3)$

We have $\angle(\theta_1 + \theta_4) = 50^\circ - 40^\circ = 10^\circ$

But, $\angle(\theta_2 + \theta_3) = 30^\circ - 50^\circ = -20^\circ$

Thus, the angle criterion for balance is not satisfied. Hence, the bridge is not balanced.

4. (a) Write a short note on megger and earth tester.

(8)

Refer Section 4.4.4 in Chapter 4 on Measurement of Resistance.

(b) Draw the circuit diagram of Anderson's bridge. Derive the equation for unknown inductance and draw the phasor diagram.

(8)

Refer Section 6.4.4 in Chapter 6 on ac Bridges.

5. (a) Explain two-wattmeter method for measuring power in an $(R + L)$ load. Draw the phasor diagram.

(8)

Refer Section 7.7.2(3) and Figure 7.23 in Chapter 7 on Power Measurement.

(b) Write a short note on digital multi-meter.

(8)

Refer Section 10.4 in Chapter 10 on Electronic Instruments.

6. (a) A wattmeter reads 5 kW when its current coil is connected in red phase and its voltage coil is connected between neutral and red phase of a symmetrical 3-phase system supplying a balanced three-phase inductive load of 25 A at 440 V. What will be the reading of the wattmeter if the connections of current coil remain unchanged and voltage coil be connected between blue and yellow phase? Hence determine the total reactive power in the circuit. Draw the diagram in both the cases.

(8)

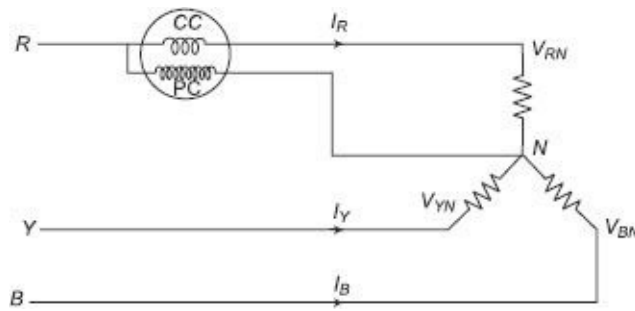

Figure 3

In the first case, current in CC of wattmeter $I_R = I_{ph} = 25A$

Voltage in PC of wattmeter = $V_{RN} = V_{ph} = 440/\sqrt{3} = 254 V$

Hence, wattmeter reading $P_1 = V_{ph} \times I_{ph} \times \cos \phi = 5000 \text{ W}$

or, $254 \times 25 \times \cos \phi = 5000$

or, $\cos \phi = 0.787$

or, $\phi = 38^\circ$

In the second circuit,

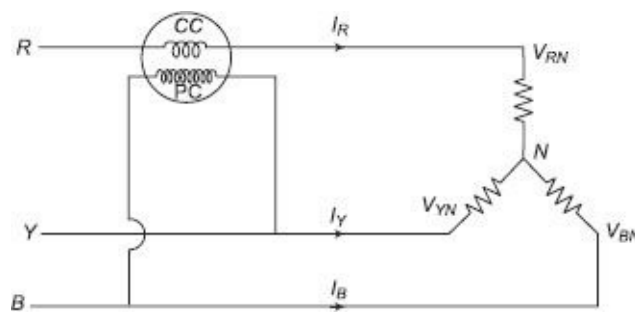

Figure 4

In the second circuit, the phasor diagram with inductive load can be drawn as

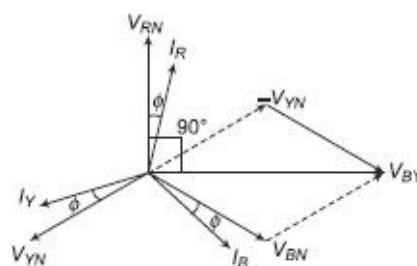

Figure 5

In this case, current in CC of wattmeter $I_R = I_{ph} = 25 A$

Voltage in PC of wattmeter = $V_{BY} = V_{LL} = 440 V$

Angle different between CC current and PC voltage $\phi' = (90^\circ - \phi) = (90^\circ - 38^\circ) = 52^\circ$

Hence, wattmeter reading $P_1 = V_{LL} \times I_{ph} \times \cos \phi' = 440 \times 25 \times \cos 52^\circ = 6.77 \text{ kW}$

Total reactive power = $\sqrt{3} \times 6.77 = 11.73 \text{ kV A}_R$

(b) Write a short note on LPF type wattmeter.

Low Power Factor Electro-dynamometer Type Wattmeters

An ordinary electro-dynamometer wattmeter is not suitable for measurement of power in low-power factor circuits owing to (i) small deflecting torque on the moving system even when the current and pressure coils are fully excited, and (ii) introduction of large error due to inductance of pressure coil at low power factor.

The special features incorporated in an electro-dynamometer type wattmeter to make it suitable for measurement of power in low-power-factor circuits are given below.

- (i) **Pressure coil Circuit** *The pressure coil circuit is made of low resistance in order to make the pressure coil current large resulting in increased operating torque. The pressure coil current in a low pf wattmeter may be as much as 10 times the value used for ordinary wattmeters.*
- (ii) **Compensation for Inductance of Pressure Coil** *The error caused by pressure coil inductance is due to difference in phase between pressure Coil current and its voltage. Now with low pf, the value of the error is large. The error caused by inductance of pressure coil is compensated by connecting a capacitor across a part of series resistance in the pressure coil circuit.*

- (c) **What are the errors in a dynamometer-type wattmeter? How are these errors compensated?**

(4)

Refer Section 7.4.4 (and summarise) in Chapter 7 on Power Measurement.

PART B

7. (a) **An energy meter has a constant of 3200 imp/kWh rated for 220 V, 5 A. Calculate the total number of impulses in one minute for full load at unity power factor. In a test run at half load, the meter takes 59.5 second to complete 30 impulses, calculate error of meter.**

(6)

Refer Example 8.1 in Chapter 8 on Measurement of Energy.

- (b) **Derive torque equation of single-phase induction-type energy meter with the help of phasor diagram.**

(8)

Refer Section 8.2.3 in Chapter 8 on Measurement of Energy.

- (c) **Show a neat connection diagram of a three-phase energy meter used for measurement of energy incorporating CT and PT.**

(4)

Refer Section 7.9 in Chapter 7 and apply exactly the same concept for connection of energy-meter coils.

OR

8. (a) A 230 V single-phase energy meter has constant load of 5 A passing through it for 8 hours at 0.9 P.F. If the meter LED makes 26500 impulses during this period, find the meter constant in imp/kWh. Calculate the power factor of the load if the number of impulses are 11230 when operating at 230 V and 6 A for 5 hours.

(6)

$$\text{Energy consumed} = \frac{230 \times 5 \times 0.9 \times 8}{1000} = 8.28 \text{ kWh}$$

The energy meter makes 26500 impulses during this time

Hence, meter constant is $26500/8.28 = 3200 \text{ imp/kWh}$

When the number of impulses are 11230, then energy consumed is 3.5 kWh

With a power factor x , $\frac{230 \times 6 \times 5 \times x}{1000} = 3.5$, thus $x = 0.5$

- (b) Which are the possible errors in an induction-type single-phase energy meter? Explain and give compensation for the errors?

(4×2)

Refer Section 8.3 in Chapter 8 on Measurement of Energy and Summarise.

- (c) What is creeping error in an induction-type energy meter? How is it overcome?

Refer Section 8.3.3 Chapter 8 on Measurement of Energy.

9. (a) Describe low-pressure measurement by McLeod gauge.

(8)

Readers can refer to reference material

- (b) In an experiment, the voltage across a $10 \text{ k}\Omega$ resistor is applied to a CR. The screen shows a sinusoidal signal of 3 cm total vertical occupancy and 2 cm total horizontal occupancy. The front panel controls of V/div and time/div are on 2 V/div and 2 ms/div respectively. Calculate the rms value of the voltage across the resistor and its frequency. Also find rms value of current.

(6)

Peak value of the sinusoidal voltage being measured = $3 \times 2 = 6 \text{ V}$

Hence, rms value = $6/\sqrt{2} = 4.24 \text{ V}$

One time period of the sinusoidal signal being measured = $2 \times 2 = 4 \text{ ms}$

Hence, frequency of the signal = $1/4 \text{ ms} = 250 \text{ Hz}$

- (c) Explain vacuum pressure.

(2)

Readers can refer to reference material.

OR

10. (a) Explain pressure capacitance transducer with a neat diagram. Write advantages and disadvantages of a capacitive transducer.

(8)

Refer Section 11.7.4 in Chapter 11 on Sensors and Transducers.

- (b) Explain front panel controls of CRO:

(8)

1. Time/div

2. Volt/div

3. Dual ch.

4. invert

5. x-position

6. y-position

7. xy-mode

8. CH1 CH2.

Refer Sections 9.2 and 9.3 in Chapter 9 on Cathode Ray Oscilloscope.

11. (a) Explain any two types of head-type flowmeters.

(8)

Readers can refer to reference material.

- (b) Explain level measurement by mechanical method.

Readers can refer to reference material.

(8)

12. (a) Explain construction, working and application of load cell with a neat diagram.

(8)

Readers can refer to reference material.

- (b) Describe displacement measurement by LVDT in detail.

Combine Sections 11.3, 11.3.1 and 11.3.2 in Chapter 11 on Sensors and Transducers.

(8)

SOLVED QUESTION PAPER-7

PART-A

1. (a) With usual notations, prove that $[1/(\mu\epsilon)^{1/2}]$ has the dimensions of velocity, where μ = permeability and ϵ = permittivity.

(5)

Readers can refer to reference material.

(b) The expression for eddy currents produced in a metallic former moving in the field of a permanent magnet is found as,

$$I_e = \frac{KB/bA}{(2b+l)\rho}$$

where B = flux density, l = length of former, b = width of former, A = Area of former, ρ = resistivity of conducting former and K = a constant.

Check for dimensional correctness of the expression and incorporate necessary corrections using LMTI system of units.

Refer to Section 2.5.3(3) in Chapter 2 on Analog Meters

(c) Define bridge sensitivity of a galvanometer and hence obtain an expression for Wheatstone's bridge sensitivity (S_B) in terms of voltage sensitivity. When will be S_B maximum?

(8)

Voltage sensitivity S_v of a galvanometer is defined as the deflection in scale divisions per unit voltage impressed on the galvanometer.

For the Wheatstone bridge configuration shown below, the sensitivity to unbalance can be computed by solving the bridge circuit for a small unbalance. The solution is approached by converting the Wheatstone bridge of Figure 1 to its "Thevenin Equivalent" circuit. Assume that the bridge is balanced when the branch resistance are P , Q , R , S so that $P/Q = R/S$. Suppose the resistance R is changed to $R + \Delta R$ creating an unbalance. This will to cause an emf e to appear across the galvanometer branch. With galvanometer branch open, the voltage drop between points a and b is:

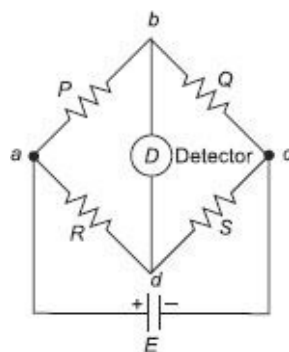

$$E_{ab} = I_1 P = \frac{EP}{P+Q}$$

Similarly, $E_{ad} = I_2 (R + \Delta R) = \frac{E(R + \Delta R)}{R + \Delta R + S}$

Therefore, voltage difference between points d and b is

$$e = E_{ad} - E_{ab} = E \left(\frac{R + \Delta R}{R + \Delta R + S} - \frac{P}{P + Q} \right)$$

and since $\frac{P}{P + Q} = \frac{R}{R + S}$

$$e = E \left[\frac{R + \Delta R}{R + \Delta R + S} - \frac{R}{R + S} \right] = \frac{ES\Delta R}{(R + S)^2 + \Delta R(R + S)}$$

$$= \frac{ES \Delta R}{(R + S)^2}$$

as $\Delta R(R + S) \ll (R + S)^2$

Let S_v be the voltage sensitivity of galvanometer. $ES R$

Therefore, deflection of galvanometer is : $\theta = S_v e = S_v \frac{ES \Delta R}{(R + S)^2}$

The bridge sensitivity S_B is defined as the deflection of the galvanometer per unit fractional change in unknown resistance.

Bridge sensitivity $S_B = \frac{\theta}{\Delta R/R} = \frac{S_v ESR}{(R + S)^2}$

It is clear that the sensitivity of the bridge is dependent upon bridge voltage, bridge parameters and the voltage sensitivity of the galvanometer.

Rearranging the terms in the expression for sensitivity

$$S_B = \frac{S_v E}{\frac{(R + S)^2}{SR}} = \frac{S_v E}{\frac{R}{S} + 2 + \frac{S}{R}} = \frac{S_v E}{\frac{P}{Q} + 2 + \frac{Q}{P}}$$

It is apparent that maximum sensitivity occurs where $R/S = 1$.

2. (a) Derive the equation of balance for an Anderson bridge. Also draw the phasor diagram

(10)

Refer Section 6.4.4 in Chapter 6 on ac Bridges.

(b) Write a short note on Wagner earthing device.

(4)

Refer Section 6.7 in Chapter 6 on ac Bridges.

(C) An ac bridge is balanced at 2 kHz with the following components in each arm: Arm

$AB = 10 \text{ k}\Omega$

Arm $AB = 100 \text{ }\mu\text{F}$ in series with $100 \text{ k}\Omega$

Arm $AD = 50 \text{ k}\Omega$

Find the unknown impedance $R \pm jX$ in the arm DC , if the detector is between BD .

(6)

Using the general bridge balance equation, we have

$$Z_{AB}Z_{DC} = Z_{AD}Z_{BC}$$

$$10(R \pm jX) = 50 \left(100k + \frac{1}{j2\pi 2000 \times 10 \times 10^{-6}} \right)$$

or, $(R \pm jX) = (500k - j39.8)$

Thus, $R = 500k$, $X = 39.8$

3. (a) **What are shunts and multipliers? Derive an expression for both, with reference to meters used in electrical circuits.**

(6)

Refer Section 2.7 in Chapter 2 on Analog Meters.

- (b) **Write a note on turns compensation used in CT and PT.**

(4)

Refer Section 3.5.4(3) in Chapter 3 on Instrument Transformers.

- (c) **A current transformer with a bar primary has 300 turns in its secondary winding. The resistance and reactance of the secondary circuit are 1.5 μ and 1.0 μ respectively, including the transformer winding. With 5A following in the secondary winding, the magnetising mmf is 100 AT and the core loss is 1.2 W. Determine the ratio and phase angle errors.**

(10)

Follow Example 3.4 in Chapter 3 on Instrument Transformers.

4. (a) **Discuss with a block diagram, the principle of operations of an electronic energy meters.**

(6)

Readers can refer to reference material.

- (b) **Mention different errors present in an induction-type energy meter and suggest methods to minimise them.**

(6)

Refer Section 8.3 in Chapter 8 on Measurement of Energy.

- (c) **An energy meter is designed to make 100 revolutions of the disc for one unit of energy calculate the number of revolutions made by it, when connected to a load carrying 40 A at 230 V and 0.4 pf for 1 hour. If it actually makes 360 revolutions, find the percentage error.**

(6)

Follow Example 8.3 in Chapter 8 on Measurement of Energy.

PART B

5. (a) **With a block diagram, explain the principle of true rms responding voltmeter.**

(6)

Refer Section 2.15 in Chapter 2 on Analog Meters.

(b) Explain the operations of RAMP type digital voltmeter.

(6)

(b) Combine Sections 10.6 and 10.6.1 in Chapter 10 on Electronic Instruments.

(c) Explain the construction and operations of Weston frequency meter.

(6)

Weston Frequency Meter: As the name suggests, Weston frequency meter is an instrument using which unknown frequency of a signal can be measured. It is basically a moving-iron-type instrument which works on the principle that whenever the frequency change the current distribution changes between two parallel circuits one of which is inductive and the other non-inductive. Any change in frequency changes the inductive impedance of the inductive arm causing current distribution to change between the two parallel paths. Figure 2 shows the constructional details of a Weston frequency meter.

The axes of the two coils A_1-A_2 and B_1-B_2 are mutually perpendicular. A soft iron needle that carries a pointer is placed at the central location within the coils. Coil A is connected in series with an inductance L_A across a non-inductive resistance R_A . Coil B is connected in series with a non-inductive resistance R_B across an inductance L_B . The other inductor L acts as a filter to remove any harmonics that may be present in the signal.

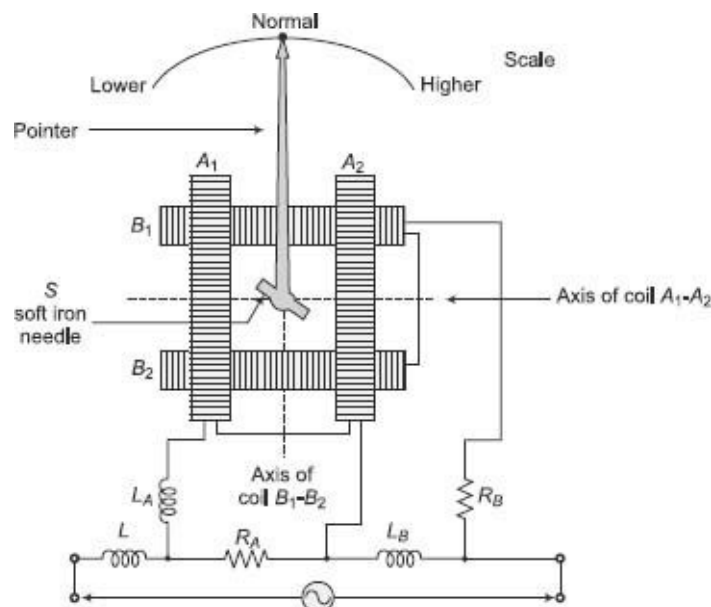

Figure 2 Weston Frequency meter

As supply is given to the system, the magnetic fields developed by the two coils are at right angles to each other. Depending on the strength of these two magnetic fields, a deflecting torque is developed that moves the soft-iron needle and hence the pointer on a calibrated scale. The deflecting torque and, hence, the amount of deflection of the pointer thus depends on the magnitude of currents in the two

coils.

Once the frequency deviates from a certain present value, the inductance values L_A and L_B change, but the resistance R_A and R_B remain the same. This makes the current distribution in the two coils change from their initial preset values. Depending on the frequency, one coil becomes stronger than the other. Thus, the deflecting torque under such condition will be different from that in the normal case and the pointer will deviate either towards left or to the right indicating lower or higher frequency than the preset value respectively.

6. (a) **What is a transducer? Briefly explain the procedure for selecting a transducer.**

(6)

Refer Sections 11.1 and 11.2 in Chapter 11 on Sensors and Transducers and summarize.

- (b) **Explain with a neat sketch, the construction and working of a linear variable differential transformer.**

(6)

Refer Section 11.3 in Chapter 11 on Sensors and Transducers.

- (c) **Derive an expression for gauge factor in terms of Poisson's ratio.**

(6)

Refer Section 11.4.1 in Chapter 11 on Sensors and Transducers.

7. (a) **With a block diagram, explain the working of a digital storage oscilloscope.**

(6)

Refer Section 9.11.2 in Chapter 9 on Cathode Ray Oscilloscope.

- (b) **Explain the front panel details of a dual trace Oscilloscope.**

(6)

Refer Section 9.112.1 in Chapter 9 on Cathode Ray Oscilloscope.

- (c) **Briefly explain photoconductive and photovoltaic cells.**

(6)

Readers can refer to reference material.

8. (a) **Explain with a block diagram, the essential functional operations of a digital data acquisition system.**

(6)

Refer Section 14.2 in Chapter 14 on Data Acquisition System.

- (b) **With a neat sketch, explain the working of an X-Y recorder.**

(06)

Refer Section 15.2.1(3) in Chapter 15 on Recording, Storage and Display Devices.

(c) Write a note on LED and LCD display.

(06)

Refer Sections 15.4.2 and 15.4.3 in Chapter 15 on Recording, Storage and Display Devices.

SOLVED QUESTION PAPER-8

1. (a) The following 10 observations were recorded when measuring a voltage: 31.6, 31.0, 31.7, 31.0, 32.1, 31.9, 31.0, 31.9, 32.5 and 31.8 volt. Find

(i) Probable error of one reading

(ii) Probable error of mean

(8)

x	d	d ²
31.6	-0.05	0.0025
31	-0.65	0.4225
31.7	0.05	0.0025
31	-0.65	0.4225
32.1	0.45	0.2025
31.9	0.25	0.0625
31	-0.65	0.4225
31.9	0.25	0.0625
32.5	0.85	0.7225
31.8	0.15	0.0225
$\sum x = 316.5$		$\sum d^2 = 2.345$

$$\text{Mean} = \sum x/n = 316.5/10 = 31.65$$

(i) Probable error of one reading = $0.6745 \sqrt{\frac{\sum d^2}{n-1}} = 0.1757 \text{ V}$

(ii) Probable error of mean = $0.6745 \sqrt{\frac{\sum d^2}{n(n-1)}} = 0.0556 \text{ V}$

(b) Define the following for Gaussian distribution of data:

(i) Precision index

(ii) Probable error

(iii) Standard deviation of mean

(iv) Standard deviation of standard of deviation.

(8)

Refer Section 1.7 in Chapter 1 on Concepts of Measurement Systems.

OR

OR

(a) A circuit was tuned for resonance by eight different student and the values of resonant frequency in kHz were recorded as 432, 447, 444, 435, 446, 444, 436

and 441. Calculate

(i) Standard deviation

(ii) Variance

(8)

x	d	d ²
432	-8.635	74.390625
447	6.375	40.640625
444	3.375	11.390625
435	-5.625	31.640625
446	5.375	28.890625
444	3.375	11.390625
436	-4.625	21.390625
441	0.375	0.140625
$\sum x = 3525$		$\sum d^2 = 219.875$

(i) Standard deviation $\sqrt{\frac{\sum d^2}{n}} = \sqrt{\frac{219.875}{8}} = 5.24$

(ii) Variance = (standard deviation)² = 10.48

(b) Define the following with suitable examples.

(i) Precision

(ii) Accuracy

(iii) Repeatability

(iv) Drift related to the instruments

(8)

Refer Section 1.7 in Chapter 1 on Concepts of Measurement Systems.

2. (a) Explain the block diagram of a dc voltmeter with direct coupled amplifier.
DC Voltmeter using Direct Coupled Amplifier

(8)

This type of voltmeter is very common because of its low cost. This instrument can be used only to measure voltages of the order of millivolts owing to limited amplifier gain. An attenuator is used in the input stage to select voltage range. A transistor is a current-controlled device; so resistance is inserted in series with the transistor Q_1 to select the voltage range. It can be seen from Fig. 1 that sensitivity of the voltmeter is 200 kilo-ohms/volt, neglecting the small resistance offered by the transistor Q_1 . Other values of range-selecting resistors are also so chosen that sensitivity remains the same for all ranges. So current drawn from the circuit is only 5 micro-amperes.

Two transistors in cascaded connections are used instead of a single transistor for amplification in order to keep the sensitivity of the circuit high. Transistors Q_1 and Q_2 are taken complementary to each other and are directly coupled to minimise the number of components in the circuit. They form a direct coupled amplifier. A variable resistance R is put in the circuit for zero adjustment of the PMMC. It controls the bucking current from the supply E to buck out the quiescent current. The drawback of such a voltmeter is that it has to work under specified ambient temperature to get the required accuracy otherwise excessive drift problem occurs during operation.

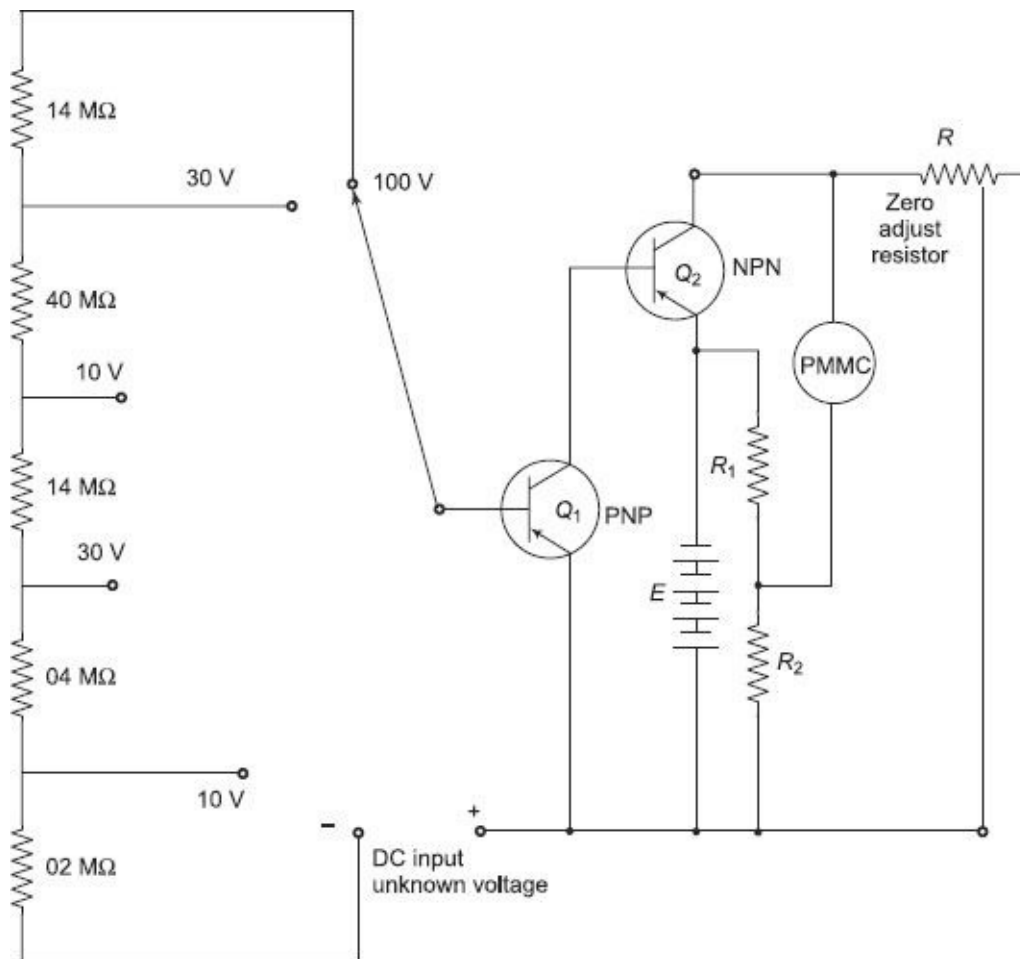

Figure 1 Direct coupled amplifier dc voltmeter using cascade shows a transistor

(b) Explain the working principle of vector impedance meter with neat sketch.

(8)

Readers can refer to reference material

OR

(a) What do you mean by the term 'Q-factor'. Explain the working of Q-meter.

(8)

Readers can refer to reference material

(b) Write short notes on RF power and voltage measurements.

(8)

Refer Section 17.7 in Chapter 17 on Microwave and RF Measurement.

3. (a) Calculate the velocity of the electron beam in an oscilloscope if the voltage applied to its vertical deflection plates is 2200 V. Also calculate the cut-off frequency if the maximum transit time is 1/4 of a cycle. The length of horizontal plates is 65 mm.

(8)

$$\text{Velocity of the electron beam} = v_{ox} = \sqrt{\frac{2eE_a}{m}} = \sqrt{\frac{2 \times 1.6 \times 10^{-19} \times 2200}{9.1 \times 10^{-31}}} = 27.8 \times 10^6 \text{ m/s}$$

[Refer Example 9.1 in Chapter 9 on Cathode Ray Oscilloscope.]

$$\text{Cut-off frequency} = \frac{v_{ox}}{4l} = \frac{27.8 \times 10^6}{4 \times 65 \times 10^{-2}} = 10.7 \text{ MHz}$$

- (b) Explain the following terms of CRO:

(i) Blanking circuit

(ii) Astigmatism control

(8)

(i) **Blanking circuit** The purpose of a sawtooth signal applied to the horizontal deflecting plate of a CRO is to move the beam across the CRT from left to right along the horizontal direction. If this rate is slow then the moving point will be visible, and if this rate is very fast then a solid line is visible. After the spot reaches the rightmost point, it has to come back swiftly to the initial point, i.e. the leftmost point. This 'fly-back' time should be as fast as possible. Ideally, this fly-back time should be zero so that retrace of the spot is not visible. In a practical circuit, to eliminate this retrace, a 'blanking circuit' is used that applies a high negative potential to the grid during the fly-back period that pushes back the spot rapidly to its starting point.

(ii) **Astigmatism control** In the human eye, astigmatism causes light to be focused away from its intended target, the retina. Astigmatism is mainly due to curvature of the cornea. A similar case may be observed in a CRO where due to curvature of the screen, the electron beam may not be focused properly on the screen and may appear blurred. In modern oscilloscopes, an additional focusing control marked as *astigmatism* is provided. To focus the spot correctly, it is made to stop near the centre of the screen by switching off the time base and adjusting the X and Y positioning controls. The spot is then made as sharp as possible at the centre of the screen by repeated adjustments of the focusing and astigmatism controls.

OR

- (a) Explain the different types of sweep used in a CRO.

(8)

Refer Section 9.5 in Chapter 9 on Cathode Ray Oscilloscope.

(b) Explain the following terms of CRO:

(i) Z-axis modulation

(ii) Sources of synchronization

(8)

(i) Z-axis modulation is actually intensity control. It is done by inserting a control signal between the cathode and ground or between the control grid and the ground. It is used for controlling the brightness of display. A series of negative pulses are applied to the cathode to make the display brighter during its sweep period. Alternatively, a series of positive pulses can also be applied to the control grid to achieve the same function of brightening the display.

(ii) There are normally three sources of synchronisation—internal, external and line. In internal synchronisation, the trigger is obtained from the signal being measured itself, through the vertical amplifier. In the external synchronisation method, an external trigger source is used to trigger or initiate the signal to be measured. In the line synchronisation method, the trigger signal is obtained from the power supply line to the CRO.

4. (a) Explain the working of frequency synthesised signal generators with a neat sketch.

(8)

Refer Section 13.15 in Chapter 13 on Signal Generators and Analysers.

(b) Explain the block diagram of frequency-selective wave analyzer. (8)

Refer Section 13.16.1 in Chapter 13 on Signal Generators and Analysers.

OR

(a) Explain the construction and working of a heterodyne wave analyzer.

(8)

Refer Section 13.16.21 in Chapter 13 on Signal Generators and Analysers.

(b) Explain the block diagram of spectrum analyser and its applications.

(8)

Refer Section 13.18 in Chapter 13 on Signal Generators and Analysers.

Unit-V

5. Write short notes on the following:

(a) Seismic accelerometers

(8)

Readers can refer to reference material.

(b) RVDT

(8)

Readers can refer to reference material.

OR

Write shorts notes on the following:

(a) Ultrasonic flowmeters

(8)

Readers can refer to reference material.

(b) Thermocouples.

(8)

Refer Section 11.6.2 in Chapter 11 on Sensors and Transducers.

SOLVED QUESTION PAPER-9

1. Answer any Four:

(20)

- (a) **Define sensitivity of an analog instrument. For a PMMC instrument with FSD = 100 mA, find the sensitivity.**

Sensitivity of a voltmeter is defined as Total voltmeter resistance in ohm 1 S
==W/V

$$S = \frac{\text{Total voltmeter resistance in ohm}}{\text{Full-scale reading in volts}} = \frac{1}{I_{\text{FSD}}} \Omega/\text{V}$$

For FSD = 100 mA, sensitivity $S = 1/(100 \times 10^{-3}) = 10$

- (b) **What is Meggar? Explain its working.**

Refer Section 4.4.4 in Chapter 4 on Measurement of Resistance.

- (c) **For ADC, define resolution. Given a suitable example.**

Refer Section 10.3(a) in Chapter 10 on Electronic Instruments.

- (d) **Explain the working principle of a dc motor.**

Readers can refer to reference.

- (e) **Explain the function of delay line in oscilloscope. What are the types of delay lines?**

The delay line is used to delay the incoming vertical signal and synchronise it with the horizontal signal. Old scopes used a series of LC combinations tuned to get a good waveform representation. Modern oscilloscopes use two types of delaying methods, namely free running sweep and triggered sweep.

[For the remaining part of the answer, refer Sections 9.5.1 and 9.5.2 in Chapter 9 on Cathode ray Oscilloscopes]

2. (a) **What is intensity modulation? For what purpose is it used? Can phase and frequency be measured using intensity modulation?**

10

Readers can refer to reference.

- (b) **What is Q meter? Explain any one of the types of Q-meter with the help of circuit diagram.**

(10)

In most radio frequency work, it is important to obtain a large ratio of reactance to resistance in the reactive elements of the circuit. This ratio is called the Q of the circuit.

$$Q = \frac{X_L}{R} = 2\pi f \frac{L}{R} = \frac{X_C}{R} = \frac{1}{2\pi fCR}$$

A high Q is required to obtain good efficiency, good waveform, good frequency stability, high gain, etc.

The Q -meter is required to obtain good efficiency the Q of a reactance element directly. It may also be used to measure

- the reactance and resistance of a circuit,
- the distributed capacity of a circuit, and
- the resonant frequency of a tuned circuit, etc.

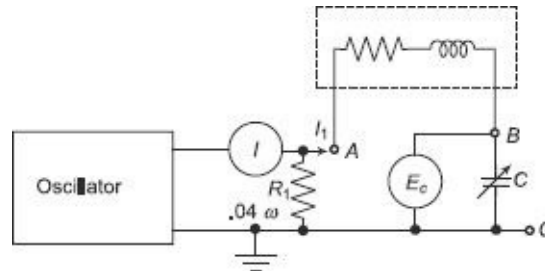

Figure 1

Figure 1 shows the fundamental circuit of Q -meter.

The oscillator supplies a current I to R' and the unknown and C . Since R' is very small compared with the impedance of the external circuit, the voltage E is equal to IR' . Hence, the reading I gives an indication of the voltage impressed on the circuit.

If the unknown and C are tuned to resonance (i.e. C adjusted until $E_c = \text{Max.}$),

$$I' = \frac{E}{R} \tag{1}$$

where R is the effective series resistance of the unknown and C . Also,

$$E_c = I'X_C = \frac{EX_C}{R} = QE \tag{2}$$

Hence, if E is held constant by holding I constant, E_c reads directly proportional to Q and this meter may be calibrated directly in terms of Q . Since E_c is proportional to E , I may be calibrated in terms of a multiplying factor for extending the Q range of the instrument.

3. (a) Draw and explain Kelvin's Bridge.

(10)

Refer Section 4.3.2 in Chapter 4 on Measurement of Resistance.

(b) Explain the operating principle of 3-phase induction motor.

(10)

Readers can refer to reference material.

4. (a) Draw and explain the block diagram of digital storage oscilloscope.

(10)

Refer Section 9.11.2 in Chapter 9 on cathode Ray Oscilloscope.

- (b) Explain R–2 R ladder technique of digital to analogue converter.** (10)

Readers can refer to reference material.

- 5. (a) Draw and explain any one of the types of electronic voltmeters. State its two advantages over analog voltmeter.** (10)

Refer Sections 10.6 and 10.6.1 in Chapter 10 on Electronic Instruments.

- (b) Explain digital phase meter using flip-flop. Draw relevant waveforms at each point in a block diagram to illustrate.** (10)

Readers can refer to reference material.

- 6. (a) Explain Schering bridge for measurement of capacitance. Derive the equation of unknown capacitance at balanced condition.** (10)

Refer Section 6.5.2 in Chapter 6 on ac Bridge.

- (b) What is energy meter? Draw its constructional view and explain.** 10

Refer Section 8.2.2 in Chapter 8 on Measurement of Energy.

- 7. Write short notes on (any two):** 20

- (a) Variable reluctance stepper motor.**

Readers can refer to reference material.

- (b) A.F. signal generator**

Refer either Section 13.5 or 13.6 on Chapter 6 on Signal Generators and Analysers.

- (c) Digital frequency meter.**

Refer Section 10.5 in Chapter 10 on Electronic Instruments.



Index

A

Absolute error [1.17](#)
Absolute instruments [2.1](#)
Accelerating voltage [9.5](#)
Accuracy [1.16](#), [10.4](#), [10.3](#)
AC potentiometers [5.13](#), [12.29](#)
Actual transformation ratio [3.31](#)
A/D Conversion [14.14](#)
Adjacent Channel Power [17.4](#)
Advantages and Disadvantages of LVDT [11.4](#)
Advantages of electrical transducers [11.2](#)
Advantages of Electromagnetic Flow Meter [11.10](#)
Air friction [2.3](#)
Air-friction damping [2.8](#)
Aliasing [14.14](#)
Aluminum disc [7.22](#)
Aluminum spindle [7.9](#)
Aluminum vanes [7.10](#)
Ammeter shunts [2.18](#)
Ampere [1.4](#)
Amplification [14.10](#)
Amplitude distortion [13.36](#)
Amplitude Modulation (AM) [17.9](#)
Amplitude Shift Keying (ASK) [17.11](#)
Analog input subsystems [14.4](#)
Analog instruments [2.1](#), [2.2](#), [1.13](#)
Analog modulation [17.9](#)
Analog Output Subsystem [14.4](#), [14.19](#)
Analog Recorders [15.2](#)
Analog sensors [14.5](#)
Analog Storage Oscilloscope [9.18](#)
Analog-to-Digital Converter (DACs and ADCs) [9.20](#)
Analysers [13.1](#)
Anderson's Bridge [6.11](#)
Angle of incidence [18.1](#)
Angle of refraction [18.1](#)
ANSI/IEEE Standard 488.1-1987 [14.26](#)

Antenna size [17.2](#)

Application Software [14.13](#)

Aquadog [9.1](#)

Arbitrary waveform generator [10.14](#)

Astatic [7.18](#)

Astatic electrodyamometer instruments [7.18](#)

Avalanche Diode [18.6](#)

Average deflecting torque [7.11](#)

B

Ballistic galvanometer [12.1](#)

Band-Pass (selective) Filter [14.8](#)

Band-stop (Notch) Filter [14.9](#)

Barkhausen Criteria [13.3](#)

Barretter [17.16](#)

Bar-type CT [3.15](#)

Baseband signal [17.15](#)

Basic Requirements of a Transducer [11.2](#)

Basic Transistor LC Oscillator Circuit [13.5](#)

Bearings [2.5](#)

BFSK [17.12](#)

Binary Weighted DAC [14.20](#)

Blondel's Theorem [7.25](#)

Bolometer [17.16](#)

Brake magnet [8.5](#)

Bridge and ac Potentiometer Methods [12.27](#)

Burden [3.2](#)

Burrows Permeameter [12.23](#)

Bushing-type CT [3.16](#)

Butterworth Filter [14.10](#)

C

Calibration of ammeter [5.6](#), [5.18](#)

Calibration of Ammeter by Potentiometer [5.10](#)

Calibration of the Ballistic Galvanometer [12.5](#)

Calibration of voltmeter [5.5](#), [5.18](#)

Calibration of Voltmeter by Potentiometer [5.9](#)

Calibration of wattmeter [5.6](#), [5.19](#)

Calibration of Wattmeter by Potentiometer [5.10](#)

Capacitance standards [1.3](#)

Capacitive Transducers [11.23](#)

Cathode Ray Oscilloscope (CRO) [9.1](#)

Cathode Ray Tube (CRT) [9.1](#), [15.18](#)

Central Processing Unit (CPU) [16.4](#)
Characteristic frequency [13.15](#)
Circular Chart Recorder [15.6](#)
Clamp on type CTs [3.16](#)
Cold Cathode Display [15.19](#)
Cold junction [11.15](#)
Colpitts Crystal Oscillator [13.16](#)
Colpitts Oscillators [13.9](#)
Communication Systems [17.14](#)
Comparison between different types of instruments [2.47](#)
Comparison methods [1.8](#)
Compensating coil [7.17](#)
Compensation for pressure coil inductance [7.15](#)
Compensation for voltage variation [8.14](#)
Conductive mesh [9.19](#)
Contacts and lead resistances [4.20](#)
Controller [14.26](#)
Controlling system [2.3](#)
Controlling torque [2.2](#), [2.3](#), [7.11](#)
Control Program [16.2](#)
Coordinate Potentiometer [5.14](#)
Counters [16.3](#)
Counter/Timer and Pulse I/O [14.26](#)
Counter/Timers Subsystems [14.4](#)
Counting system [8.6](#)
Creeping Error [8.12](#)
Creep test [8.14](#)
Critical angle [18.1](#)
Critically damped [2.3](#)
Crompton's dc potentiometer [5.2](#)
Cross-over Distortion [13.36](#)
Crystal Oscillators [13.14](#)
CT transformation [8.5](#)
Current coil [1.3](#), [2.32](#), [2.33](#), [7.5](#)
Current standards [4.19](#)
Current terminals [3.2](#)
Current transformer [7.35](#), [14.6](#)

D

D/A Conversion [14.19](#)
DAC Performance [14.22](#)
Damping force [2.3](#)

Damping torque [2.2](#)
DAQ [14.3](#)
DAQ Hardware [14.3](#)
Data acquisition [14.1](#)
Data Logger [15.15](#)
Dead zone [1.16](#)
Deflecting plates [9.1](#)
Deflecting system [2.3](#)
Deflecting torque [2.2](#), [2.14](#)
Deflection factor [9.5](#)
Deflection methods [1.8](#)
Deflection sensitivity [9.5](#)
Deflection-type instrument [1.15](#)
Delta-sigma modulation [14.20](#)
Derived units [1.2](#)
De Sauty's bridge [6.17](#)
Detection of Low Level Signals [10.2](#)
Determination of Hysteresis Loop [12.17](#)
Determination of Magnetising Curve [12.15](#)
Dielectric losses [6.18](#)
Differential transformers [11.22](#)
Digital frequency meter [10.7](#)
Digital input/output subsystems [14.4](#)
Digital inputs [14.24](#)
Digital instruments [1.13](#)
Digital modulation [17.11](#)
Digital multimeter [10.5](#)
Digital pattern generator [10.14](#)
Digital recorders [15.15](#)
Digital sensors [14.5](#)
Digital storage oscilloscope [9.19](#)
Digital tape recording [15.17](#)
Digital to Analog (D/A) converter [10.4](#)
Digital Voltmeter (DVM) [10.9](#)
Diode detector [17.17](#)
Direct comparison methods [1.8](#)
Direct deflection method for high resistance measurement [4.26](#)
Display system [15.18](#)
Dissipation factor [6.19](#)
Dot Matrix Display [15.22](#)
Driver Software [14.13](#)
Drysdale polar potentiometer [5.14](#)

[DSO 9.19](#)

[Dual Beam Oscilloscopes 9.23](#)

[Dual-Slope Integrating-Type DVM 10.11](#)

[Dual trace oscilloscopes 9.21](#)

[Dynamic range 14.22](#)

[Dynamometer 7.5](#)

[Dynamometer-type wattmeter 7.5](#)

E

[Eddy-current damping 2.8, 2.10](#)

[Eddy-current Errors 7.17](#)

[Eddy current losses 3.18](#)

[Eddy currents 2.3](#)

[Effect of power factor on wattmeter readings 7.29](#)

[Electrical instruments 1.14](#)

[Electrodynamic ammeter 2.32](#)

[Electrodynamic voltmeter 2.32](#)

[Electrodynamic wattmeter 2.33](#)

[Electromagnetic Flow meter 11.7](#)

[Electromagnetic spectrum 17.1](#)

[Electromagnetic wave spectra 17.3](#)

[Electron gun 9.1](#)

[Electronic instruments 1.14, 10.1](#)

[Electronic voltmeter \(EVM\) 10.2](#)

[Electrostatic instruments 2.37](#)

[Electrothermal instruments 2.41](#)

[Environmental errors 1.21](#)

[Error caused by vibration of the moving system 7.19](#)

[Error due to connection 7.16](#)

[Error due to overload 8.13](#)

[Error due to pressure coil capacitance 7.15](#)

[Error due to pressure-coil inductance 7.13](#)

[Error due to voltage variations 8.14](#)

[Errors in a Wheatstone bridge 4.16](#)

[Errors in Electrodynamic-type Wattmeter 7.13](#)

[Errors occurring during the Measurement using thermocouple 11.16](#)

[Error Vector Magnitude \(EVM\) 17.13](#)

[Ewing Double Bar Permeameter 12.21](#)

[Extension of range of PMMC Instruments 2.18](#)

[Extension of range of rectifier instrument 2.45](#)

[External magnetic fields 7.18](#)

F

Fibre optic power measurement [18.7](#)
Fictitious loading [7.9](#)
Field coils [2.28](#)
Filtering [14.5](#)
Fixed coils [2.29](#)
Flash/Parallel [14.15](#)
Flat panel display [15.26](#)
Flow meters [2.3](#)
Fluid friction [2.8](#)
Fluid-friction damping [2.9](#), [11.19](#)
Fluxmeter [12.8](#)
FM recording [15.13](#)
Force summing devices [4.19](#)
Four terminals [9.7](#)
Free running [9.7](#)
Free running sweep [10.6](#)
Frequency counter [10.7](#)
Frequency distortion [13.35](#)
Frequency generator [9.24](#)
Frequency Modulation (FM) [17.10](#)
Frequency range of oscilloscope [2.17](#)
Frequency Selective Wave Analyser [13.33](#)
Frequency Shift Keying (FSK) [17.12](#)
Full-scale deflection [2.18](#)
Function Block Diagrams (FBD) [16.12](#), [16.16](#)
Function generator [1.2](#), [13.26](#)

G

Gall Coordinate Potentiometer [5.15](#)
Galvanometer [4.17](#)
General Purpose Interface Bus (GPIB) [14.26](#)
Graphic Recorders [15.2](#)
Gravity Control [2.7](#)
Gross error [1.19](#)
Guarantee errors [1.17](#)
Guard arrangement [4.25](#)
Guard circuits [4.25](#)

H

Hair-spring [2.6](#)
Hand-held programming [16.8](#)
Hard beam [9.5](#)
Harmonic distortion [17.5](#)

Harmonic distortion analysers [13.35](#)

Hartley Oscillator [13.6](#)

Hay's bridge [6.9](#)

Heterodyne Sweep Generator [13.31](#)

Heterodyne Wave Analyser [13.33](#)

High Output Signal Quality [11.2](#)

High-Pass Filter [14.7](#)

High Q inductors [6.9](#)

High Reliability and Stability [11.2](#)

High Resistances [4.1](#)

Hopkinson Permeameter [12.19](#)

Hot-wire Instrument [2.41](#)

Hybrid DAC [14.21](#)

Hybrid Recorders [15.9](#)

Hysteresis [3.18](#), [11.2](#)

I

IEEE 488 Interface [14.26](#)

Illiovi Permeameter [12.22](#)

Image Table Addresses [16.9](#)

Indicating instruments [1.13](#)

Indirect comparison methods [1.8](#)

Indirect measurement methods [1.8](#)

Induction-type instruments [2.39](#)

Induction-type wattmeter [7.22](#)

Inductive transducer [11.3](#), [11.20](#)

In-phase' potentiometer [5.15](#)

Input/Output (I/O) Modules [16.6](#)

Input Relays [16.3](#)

Input resistance [10.2](#)

Insertion errors [7.2](#)

Instantaneous power [7.6](#)

Instantaneous torque [7.11](#)

Instrumental errors [1.21](#)

Insulation resistance [4.30](#)

Integrating instruments [1.13](#)

Integrating-Type DVM (Voltage to Frequency Conversion) [10.13](#)

Inter-modulation Distortion [13.36](#)

Internally reflected [18.1](#)

Internal Triggering (INT) [9.8](#)

Internal Utility Relays [16.3](#)

International ampere [1.4](#)

International standards [1.2](#)
Inter-turn capacitance [7.15](#)
I/O Addresses [16.9](#)
Ionisation transducers [11.26](#)

J

Jewel bearings [7.9](#)
Jewels [2.5](#)

K

Kelvin's Double-Bridge Method for Measuring Low Resistance [4.20](#)
Kilowatt-hour (kWh) [8.1](#)

L

Ladder diagrams [16.12](#)
LASER [18.4](#)
LCD [15.23](#)
LC oscillator [10.16](#)
LC Oscillatory Circuit [13.3](#)
Leakage flux [12.25](#)
LED [15.19](#)
Light Emitting Diode (LED) [15.19](#), [18.3](#)
Limiting error [1.17](#)
Linear Error [10.4](#)
Linearisation [14.11](#)
Linearity [11.2](#)
Linear Variable differential Transformer (LVDT) [11.3](#)
Liquid Crystal Display (LCD) [15.23](#)
Lissajous patterns [9.12](#)
Listener [14.26](#)
Loading effect [1.22](#), [10.2](#)
Localisation of cable faults [4.33](#)
Loop tests [4.33](#)
Loss angles [6.20](#)
Loss of charge method for high resistance measurement [4.29](#)
Low-pass filter [14.6](#)
Low resistances [4.1](#)
Luminosity [9.5](#)

M

Magnetic disk and tape type recorder [15.11](#)
Magnetic flow meters [11.7](#)
Magnetic measurements [12.1](#)
Magnetic meter (Magmeter) [11.8](#)

Magnetic shielding [12.30](#)

Magnetic shunt [8.14](#)

Magnetic tape [15.11](#)

Magnetic testing [12.26](#)

Manual instruments [1.15](#)

Mark frequency [17.12](#)

Maximum sampling frequency [14.22](#)

Maxwell's bridge method [12.28](#)

Maxwell's inductance bridge [6.4](#)

Maxwell's inductance-capacitance bridge [6.6](#)

Measurement of current by potentiometer [5.6](#)

Measurement of energy [8.1](#)

Measurement of flux density [12.11](#)

Measurement of frequency [9.12](#)

Measurement of high voltage by potentiometer [5.6](#)

Measurement of loss [18.8](#)

Measurement of low resistances [4.19](#)

Measurement of magnetic flux by Ballistic galvanometer [12.4](#)

Measurement of magnetic leakage [12.25](#)

Measurement of magnetising force (H) [12.13](#)

Measurement of power by potentiometer [5.8](#)

Measurement of resistance by potentiometer [5.7](#)

Measuring RF voltages with a voltmeter [17.17](#)

Mechanical instruments [1.14](#)

Medium resistances [4.1](#)

Megger [4.30](#)

Megohmmeter [4.30](#)

Merits and demerits of digital instruments over analog [10.2](#)

Meter constant [8.1](#)

Microprocessor clocks [13.17](#)

Microwave [17.3](#)

Modified De Sauty's bridge [6.18](#)

Modulated signal [17.9](#)

Modulating signal [17.9](#)

Modulation [17.9](#)

Modulation Error Ratio (MER) [17.13](#)

Modulation oscillator [10.16](#)

Mono shot [13.19](#)

Monostable multivibrator circuits [10.3](#)

Monotonicity [10.4](#)

Moving coil [2.28](#), [2.29](#)

Moving Iron or MI [4.6](#)

Multimode fibres [18.2](#)

Multi-range series ohmmeter [7.12](#)

Murray Loop Test [4.34](#)

N

Network analyser [17.7](#)

Network scattering parameters [17.9](#)

Nixie tube [15.27](#)

Noise floor [17.5](#)

Noise shaping [14.20](#)

Nominal ratio [3.7](#)

Non-inductive resistance [7.9](#)

Non-sinusoidal Oscillators [13.2](#)

Null-type instruments [1.15](#)

Nyquist Criterion [14.13](#)

O

Occupied bandwidth [17.4](#)

Ohmmeter [4.2](#)

One-shot [13.22](#)

OP-AMP astable multivibrator [13.19](#)

Optical detectors [18.5](#)

Optical fibre [18.1](#)

Optical power [18.7](#)

Optical sources [18.2](#)

Optical Time Domain Reflectometre (OTDR) [18.9](#)

Oscillation transducers [11.27](#)

Oscillator [13.1](#)

Oscillographic recorders [15.15](#)

Over-compensation for friction [8.12](#)

Overdamped [2.3](#)

Oversampling DACs or Interpolating DACs [14.20](#)

Owen's bridge [6.13](#)

P

Paperless recorders [15.9](#)

PC-based data acquisition system [14.3](#)

PDM recording [15.14](#)

PDP [15.26](#)

Percentage of distortion [17.5](#)

Percentage ratio error [3.8](#)

Permanent magnetisation [3.18](#)

Permanent magnet moving coil instrument [2.12](#)

Permanent Magnet Moving Coil (PMMC) [2.12](#)

Permeameters [12.19](#)
Phantom loading [8.15](#)
Phase-angle error [3.32](#), [8.9](#)
Phase distortion [13.36](#)
Phase Modulation (PM) [17.10](#)
Phase noise [17.5](#)
Phase Shift Keying (PSK) [17.12](#)
Phosphor-bronze springs [7.9](#)
Phosphors [15.18](#)
Phosphor screen [9.1](#)
Photoelectric transducers [11.24](#)
Pierce oscillator [13.16](#)
Piezoelectric transducers [11.26](#)
PIN Diodes [18.5](#)
Pivot and jewel bearings [2.4](#)
Plasma Display Panel (PDP) [15.26](#)
PLC programming terminal [16.8](#)
Polar potentiometer [5.13](#)
Portable-type CT [3.16](#)
Positive feedback [13.1](#)
Potential terminals [4.19](#)
Potential transformers or PTs [3.26](#), [7.35](#)
Potentiometer [5.1](#)
Potentiometer method for measuring low resistance [4.23](#)
Power amplifier [9.7](#)
Power in band [17.3](#)
Power measurement in AC Circuits [7.6](#)
Power measurement in DC Circuits [7.1](#)
Power measurement in polyphase systems [7.25](#)
Power measurement using thermistor [17.16](#)
Power measurement with instrument transformers [7.35](#)
Power meter [18.7](#)
Power supply [16.6](#)
Precision [1.16](#)
Pressure coil [2.33](#), [7.9](#)
Pressure measurement [11.19](#)
Price's guard-wire method [4.28](#)
Primary standards [1.2](#)
Primary transducer [11.19](#)
Programmable Logic Controllers (PLCs) [16.1](#)
Program scan time [16.11](#)
Pulse generators [13.18](#)

Pulse width modulator [14.20](#)

Q

Q factor [6.8](#)

Quality factor [14.6](#)

Quantisation [14.14](#)

Quantisation levels [14.14](#)

Quartz crystal oscillator [10.16](#)

R

R-2R Ladder DAC [14.21](#)

Radio frequency [17.1](#)

Radio frequency Spectrum Analyser [17.5](#)

Ramp/Counter [14.16](#)

Ramp-Type DVM [10.10](#)

Ramp voltage [9.6](#)

Random error [1.19](#), [1.21](#)

Range [14.19](#)

Ratio arms [4.16](#)

Ratio error [3.7](#), [3.32](#)

RC Oscillator [13.10](#)

Reactive Power Measurements [7.33](#)

Read-Only Memory (ROM) [9.20](#)

Recording instruments [1.13](#)

Rectifier-type instruments [2.43](#)

Reference cell [5.2](#)

Reference junction [11.15](#)

Relative error [3.18](#)

Remote I/O [16.10](#)

Repeatability [11.2](#)

Residual magnetism [1.3](#)

Residual reformation [11.2](#)

Resistance standards [1.16](#)

Resistance strain gauges [11.5](#)

Resistance temperature detectors [11.11](#)

Resistance thermometers [11.11](#)

Resistive transducers [11.20](#)

Resolution [2.5](#)

Resolution Bandwidth [17.4](#)

Resonance [13.3](#), [13.4](#)

RF Analysers [17.7](#)

RF communication system [17.15](#)

RF network analyser [17.7](#)

RF signal generator [13.28](#)
RF Voltage and Power Measurement [17.16](#)
Ribbon suspension [11.2](#)
Roll Off [14.6](#)

S

Sample-and-hold (S/H) [9.20](#)
Sampling [14.14](#)
Sampling oscilloscope [9.17](#)
Sawtooth waveform [9.6](#)
Scalar Network Analyser (SNA) [17.7](#)
Schering bridges [6.20](#)
Schmitt trigger [13.24](#)
Secondary emission electrons [9.19](#)
Secondary instruments [1.13](#), [2.1](#)
Secondary standards [1.2](#)
Secondary transducer [11.19](#)
Seebeck voltage [11.14](#)
Self-inductance [6.4](#)
Self-operated instruments [1.15](#)
Sensitivity [1.16](#), [2.20](#)
Sensitivity of a full-wave rectifier circuit [2.44](#)
Sensitivity of a half-wave rectifier circuit [2.44](#)
Sensitivity of rectifier-type instrument [2.43](#)
Sensor [11.1](#)
Sensors and transducers [14.5](#)
Series magnet [7.22](#)
Series-type ohmmeter [4.2](#)
Settling time [10.4](#), [8.5](#)
Seven Segment Display [15.20](#)
Shading bands [8.5](#)
Shading coil [8.9](#)
Shading loop [8.12](#)
Shading vane for friction compensation [8.12](#)
Shape of scale in electrodynamicometer-type wattmeter [7.12](#)
Shape of scale in series ohmmeters [4.4](#)
Shape of scale in shunt ohmmeters [4.7](#)
Shields [7.18](#)
Shunt [2.18](#)
Shunt magnet [7.22](#)
Shunts and multipliers [3.1](#)
Signal conditioning [14.5](#)

Signal generators [10.14](#)
Sine wave generator [13.24](#)
Single-point and multi-point recorders [15.5](#)
Sinusoidal oscillators [13.2](#)
Space frequency [17.12](#)
Space loss [17.2](#)
Spectrum analyser [13.37](#), [17.6](#)
Spectrum analysis [17.5](#)
Speed of response [1.17](#)
Spindle [2.5](#)
Spiral spring [2.3](#), [7.9](#)
Spontaneous emission [18.4](#)
Spring control [2.6](#)
Square wave generator [13.18](#)
Standard arm [4.16](#)
Standard cell [1.4](#)
Standardisation [5.2](#)
Standardize the potentiometer [5.2](#)
Standard of measurement [1.2](#)
Standard resistor [5.7](#)
Standard variable resistance [4.14](#)
Statement list [16.12](#), [16.16](#)
Storage [10.3](#)
Strain gauges [11.5](#)
Stray capacitance [7.16](#)
Strip chart recorder [15.2](#)
Substitution method for measuring resistance [4.14](#)
Successive approximation [14.15](#)
Super-Heterodyne analyser [17.6](#)
Surface leakage [4.24](#)
Suspension [2.4](#), [7.9](#)
Swamping Resistance [2.15](#)
Sweep frequency generator [13.29](#)
Sweep generator [9.7](#), [13.29](#)
Synchronisation [9.7](#)
Systematic error [1.19](#), [1.21](#)

T

Talker [14.26](#)
Taut suspension [2.4](#)
Temperature coefficient of resistance [11.11](#)
Temperature effects [8.13](#)

Temperature errors [7.19](#)
Temperature sensitivity [10.4](#)
Temperature transducers [11.11](#)
Testing of specimens [12.18](#)
THD [13.36](#)
THD+N [14.22](#)
Thermal Dot Array Recorders [15.10](#)
Thermal emfs [11.17](#)
Thermistors [11.14](#), [17.16](#)
Thermocouple [2.39](#), [17.16](#)
Thermocouple instrument [2.41](#)
Thermometer Coded DAC [14.21](#)
Three-Wattmeter Method [7.27](#)
Time and frequency standards [9.1](#)
Time base [10.14](#)
Timers [16.3](#)
Tone generator [2.6](#)
Torque/weight ratio [2.6](#), [11.1](#)
Total harmonic distortion [13.36](#)
Total internal reflection [18.1](#)
Total percentage Harmonic Distortion (THD) [17.5](#)
Transducer [10.1](#)
Transistorised Voltmeter (TVM) [9.8](#)
Triangular wave generator [13.22](#)
Trigger circuit [9.8](#)
Triggered Sweep [6.1](#)
True RMS voltmeter [2.46](#)
Tuned detector [3.31](#)
Turns ratio [7.27](#)

U

Ultraviolet Recorders [15.9](#)
Underdamped [2.3](#)
Unit of energy [8.1](#)

V

Vacuum Tube Voltmeter (VTVM) [10.1](#)
Vane [8.12](#)
Varley Loop Test [4.35](#)
Vertical deflection plates [9.2](#)
Vibration galvanometers [6.1](#)
VNA [17.8](#)
Voltage coil [7.5](#)

Voltage-controlled-oscillator [13.27](#)

Voltage Controlled Oscillator (VCO) [13.29](#)

Voltage stability [14.17](#)

Voltage standards [1.3](#)

Voltmeter-ammeter method for measuring low resistance [4.19](#)

Voltmeter-ammeter method for measuring resistance [4.11](#)

Voltmeter multipliers [2.19](#)

W

Wagner earth device [6.26](#)

Wave analyser [13.33](#)

Waveguides [18.1](#)

Weston frequency meter C.1 Wheatstone bridge [4.15](#), [9.7](#)

Wideband preamplifier [13.13](#)

Wien Bridge Oscillators [6.20](#)

Wien's bridge [6.22](#)

Wireless communication [17.2](#)

Wireless communication system [17.1](#)

Working standards [3.14](#)

X

X-Y Recorder [15.7](#)