

1

POSTMORTEM TECHNIQUES



Postmortem techniques

- Postmortem is also known as
 - Autopsy
 - Necropsy
 - Thanatopsy
 - Postmortem examination (PME).
- **Necropsy** is the study of a dead body.
- **Necro** means Dead body.
- Study of death is known as **Thanatology**.
- Procedures involved in thanatology are known as **Thanatopsy**.

History

- The 1st autopsy was conducted in 1302, by **Varignana** in Italy.
- The 1st medico-legal autopsy in India was conducted by **Buckley** on the body of **Mr. Wheeler** in Chennai.

Q1. What is the case of the 1st medico-legal autopsy in India?

Ans: Arsenic poisoning.

Autopsy Types

00:02:39



Important Information

- In Court of Law or Legal Procedures we have 2 types, Police & Magistrate inquest.

A. Medicolegal Autopsy

- It is on the inquest of either police/magistrate.
- **174 CrPC** for police inquest.
- **176 CrPC** for magistrate inquest.
- This autopsy is chosen for **unnatural deaths**.
- **Relative consent is not required**.
- It is for law purposes.
- It is done for the **whole body**.
- It is done to know the cause of death, time since death, and manner of death.
- **Most common** type in India due to the higher number of unnatural deaths.
- The dead body is returned to the investigating officer.
- It is done by a Forensic expert, RMP (Registered Medical Practitioner).

B. Pathological/Clinical Autopsy

- **Relative consent is mandatory**.
- It is mostly done in **natural deaths**.
- It is for a specific body cavity autopsy. Ex: Death due to MI is examined for the heart.
- The dead body is returned to the relative.
- It is for **academic purposes** or to improve knowledge.
- It is done by RMP (Registered Medical Practitioner).

C. Psychological Autopsy

- A person **committed suicide** is first done with a psychological autopsy.
- It is **not a PME**, it is an interview with family members of the dead person.
- It is performed to know the **mental status** of the person before suicide.
- The interview is done with family members, friends, relatives, and social media.

D. Virtual Autopsy

- It is a visual imaging technique performed in developed countries.
- It is done to find the cause of death
- **CT scan and MRI** is performed for knowing the cause of death.
- It is also known as **virtopsy**.

E. Negative Autopsy

- If there is no identification of the cause of death, after performing PME, lab investigations, and histopathological & toxicological studies.
- Prevalence of negative autopsies is **2-5%**.
- It may sometimes occur due to a lack of experience or skill.
- In cases like **vagal inhibition, laryngospasm, and epilepsy** there is a chance of a negative autopsy.
- Negative autopsy is a **completely negative finding**.

F. Obscure Autopsy

- In this autopsy we can obtain **minimal or inconclusive** findings, which is insufficient to give a conclusion.
- **Additional investigations** like lab investigations, histopathological & toxicological studies are used to conclude the cause of death.
- Obscure autopsy is a **minimal gross finding**.

Postmortem Techniques

00:14:18

A. Virchow's Method (MC)

- Very common method.
- **One-by-one organ removal**.
- Fast and easy method.

B. Ghon's/en-Block Method (G-B)

- **Targeted block (C/T/A/P)** is taken out.
- **Cervical, thoracic, abdominal, pelvic blocks** are taken out based on the requirement.
- **Thoracic block** is taken out in thoracic problems.
- **Pelvic block** is taken out in sexual assaults.
- Inter-organ relations are intact.

C. Lettule's/en-Masses/Evisceration

- Large masses (C+T+A+P) are taken out.
- Complete viscera is taken out (Evisceration).
- Blood vessels and vascular supply are intact.
- It is for minor bleeding.

Q2. Which method is used for simple bleeding?

Ans: Lettule's/en-masses/Evisceration.

D. Rokitansky/ In-situ Method

- It is an inside dissection.
- It is done in infectious diseases (HIV, Hepatitis, COVID-19).
- It is used in highly transmissible diseases.
- It is used in infants <1 year.

Q3. If a person died due to COVID-19, which postmortem technique is required?

Ans: If there is a hospital report, there is no requirement of conducting PME, because it is a transmissible disease. If it is a medicolegal case, the Rokitansky/ in-situ method is performed.

Types of Incisions

00:21:36

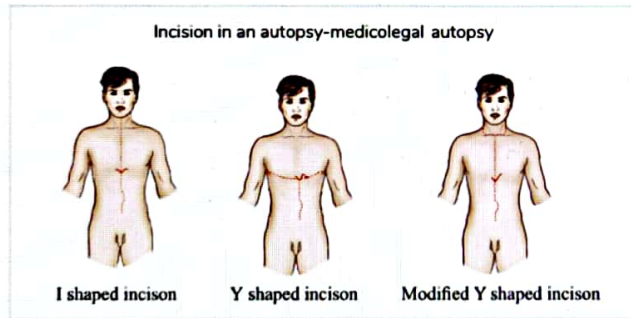

A. I-shaped Incision

- Most common type.
- It starts from the chin to pubic symphysis.

B. Y-shaped Incision

- Purpose is cosmetic, to preserve the mamillary line.
- It starts from the acromion process preserving the mamillary line reaches the breast, then to the xiphi-sternum and to pubic symphysis.

C. Modified Y-Shaped Incision

- This is done in fictional deaths (hanging, drowning).
- It starts from MP (mastoid process) to SSN (suprasternal notch) then to pubic symphysis.

D. X-incision

- It is generally not done.
- Two incisions are made from the shoulders to opposite iliac crests.
- It makes an X-mark on the body.
- It is for deep injuries/ custodial deaths.

E. Inverted Y-Shaped Incision

- It is generally not done.
- It starts from the chin and just above the umbilicus it divides into two incisions.
- It is done in infants.

F. T-Shaped Incision

- It starts from shoulder to shoulder, an incision is done in the middle.



Important Information

- Most common is I-Shaped.
- In females it is Y-Shaped for cosmetic purposes.
- In fictional cases it is a Modified Y-Shaped Incision

Body Cavity to be Opened First

00:28:21

- Generally, in PME, the thoracic cavity is opened first. In specific cases like.

A. Newborn

- Abdomen is to be opened first.
- Because the position of the diaphragm is seen.
- If the position of the diaphragm is lower, it is a live bone.
- If the position of the diaphragm is higher, it is a dead bone.
- We can estimate that the respiration has taken place or not.

B. Poisoning

- In suspected cases of poisoning, the first cavity to be opened is the cranium.
- Because the best smell of the poison can be perceived by the brain.

C. Asphyxial Deaths

- In this, Cranium-Thoracic-Abdomen-Neck (C-T-A-N) are opened in order.
- Because we want the neck as a bloodless field.
- Eg: In a throttling case, we have multiple bruises around the neck, if blood from other cavities enters the neck it would be a wrong finding.
- Hence, the last cavity opened is the neck.

D. Traumatic Head Injury

- Head is the first cavity to be opened.
- Some books may have head as the last cavity to be opened.

E. Air-Embolism/ Pneumothorax

- Pneumothorax means the air in the pleural cavity.
- In pneumothorax cases, the chest cavity (Thorax) is opened first, the skin flap is taken out and it is filled with water.
- Then puncture the pleura, if a bubble comes out, the water test is positive (Pleura has air).

- In **air embolism** cases, open the pericardium, fill it with water, and puncture the ventricle.
- If a bubble comes out, the water test is **positive** (Pleura has air).
- Another technique used in air embolism cases, a syringe is taken (**pyrogallol**), and aspirate blood from the ventricle.
- If air is present in the ventricle, the color of the pyrogallol solution turns **brown**.

Organs to be Dissected.

00:36:18

A. Brain

- It is the most **sensitive** organ.
- It can be dissected with/ without fixation.
- Fixation is done with **10% formalin** in a bucket with a string for 1 week if brain study is important.
- A **1 cm** interval is made in the **coronal** section of the brain.

B. Heart

- We use the **inflow-outflow** technique.
- Right atrium-Right ventricle, then to pulmonary artery we dissect up to the Lungs.
- Left atrium-Left ventricle, then dissect up to the Aorta.

C. Spinal cord

- Spinal cord can be opened anteriorly and posteriorly.
- **Posterior opening** is considered a better technique.
- It is opened in spinal cord poison cases like strychnine and traumatic spinal injuries.

E. Stomach

- It is done by the **Double Ligature Method**, in both cardiac and pyloric ends.
- It preserves the contents of the stomach.
- It is opened in the **greater curvature**.
- Because, in cases like acid or corrosive poisoning, the maximum damage is on the lesser curvature (**Magenstrasse**)
- To examine the lesser curvature, it opened from greater curvature by the double ligature method.

prince kumar
9928609733

F. Intestine

- **Small intestine** is dissected from the **mesenteric border**.
- **Large intestine** is dissected from the **Anterior tenia**.

G. Liver

- Liver is dissected by **Parallel dissection** technique.

Exhumation

00:42:21



Important Information

- Exhumation is digging out of the dead body in presence of a magistrate.
- It is done in the presence of a **magistrate, police, doctor**.
- It comes under section **176 (3) CrPC**.
- After digging out of the body, a secondary autopsy is done if needed.
- Identify the site with the help of relatives or the accused.
- It is done **early in the morning** because the whole daylight is required.
- There is **no limit for exhumation**, it might continue for a few days too.
- Soil sample (**500gm**) from the body and control sample is also taken, to make a comparison.
- Bones and tissues are taken for chemical or toxicological analysis.
- Arsenic present in the soil can go into the dead body, this process is known as **postmortem imbibition**.

Definitions

00:46:42

Antemortem thrombus: It is a firm, dark red, **striae of Zahn** coralline platelet thrombus.

Q4. What is the striae of Zahn?

Ans: It is a fine white line of fibrin.

Q5. What is the coralline platelet thrombus?

Ans: It is the alternate layers of platelets and fibrin.

Postmortem Clot

- **Red current jelly:** Blood clots rapidly
- **Chicken fat clot:** The clotting process is slow

Sudden Death

- Death is said to be sudden when a person not known to have been suffering from any dangerous disease, injury, or poisoning is found dead or dies within **24 hours** after the onset of terminal illness.
- Left anterior descending artery (LAD) within 2 cm of its origin is the mostly affected.
- LAD is also called a **Widow artery**.



CROSS WORD PUZZLES

Crossword Puzzle

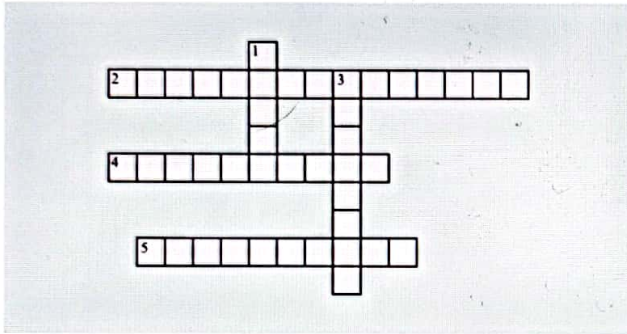

Across

- 2. Blood clots rapidly
- 4. Head is the first cavity to be opened
- 5. It is an inside dissection

Down

- 1. It is the most sensitive organ.
- 3. the study of a dead body.

prince kumar
princeeeekum@gmail.com
9928609733



2

IPC SECTIONS

IPC (Important)

00:00:02

- IPC - Indian Penal Code.
- This law was implemented in 1860.
- We'll discuss.
 - Definition of crime,
 - Punishment for that crime.
- There are 511 IPC.

- Act **not intended** and not known to be likely to cause death or grievous hurt, done by consent.
- The consent can be.
 - Expressed consent.
 - Applied consent.

Criminal Responsibility/Liability

• 82 IPC

- 82 IPC - A child below 7 years of age is **not punishable or liable** for any crime.
- Minimum age of criminal responsibility = **7 years** (Gets the advantage of juvenile justice act, where juveniles are <18 years).
- But according to the Railway Act, the Minimum age of criminal responsibility = **5 years**.
- Minimum age of FULL criminal responsibility = **Above 18 years**

prince kumar
princeekum@gmail.com
9928609733

• 83 IPC

- 83 IPC - A child between 7-12 years **can be punishable or liable** for any crime but depends on the mental maturity.
- Determined by - **Court of Law**.

• 84 IPC-I: I for Insane

- The **insane are not responsible or liable** for the crime.
- According to 84 IPC, the insane have an unsound mind.

• 85 IPC-I: I for Intoxication (Involuntary)

- In **involuntary intoxication** (Like some other intoxicated person), and then someone commits the crime they are not responsible or liable for the crime.

• 86 IPC-I: I for Intoxication (Voluntary)

- In case of **voluntary intoxication**-Voluntarily Drunkenness.
- The person under voluntary intoxication commits the crime they are responsible or liable for the crime.

Consent

- It is a part of the Indian Contract Act.
- 87 IPC
 - Age - Above 18 years of age.

Examples:

- Two people are playing with a sword with each other's consent, they're not producing any cause of death or grievous hurt.
- Paragliding on your consent.
- After or at 18 years, consent for surgery can be given.

• 88 IPC

- Act **not intended to cause death**, done by consent in good faith for a person's benefit.
- No age requirements.
- **Example:** A doctor performs surgery on X, it is done by consent in good faith for a person's benefit and not intended to cause death.

• 89 IPC

- Act **done in good faith** for the benefit of a child or insane person, by or by consent of the guardian (lawful charge).

• 90 IPC

- Consent is **not valid from a child <12 years**, insane, intoxicated, under the influence of threat or fear.

• 92 IPC

- Consent- **Life-threatening or emergency situations**.
- **Example:**
 - RTA (Road traffic accident), in case of severe bleeding, multiple fractures and multiple haemorrhages all over the body. Then the doctor can start the treatment without any consent (Exception - Consent is not needed).

Legal and Court Proceeding

00:12:09

Trick 01: Rule of 4 (Gap of 4 numbers between the sections).

- 174 IPC - Punishment for not attending the summon.
- 178 IPC - Punishment for not taking an oath or refusing of oath.

Trick 02: Rule of 4 (Gap of 4 numbers between the sections).

- 193 IPC - Punishment for false/fabrication of evidence.
 - Punishment - 7 years.



Important Information

191 IPC and 192 IPC define the crime and the 193 IPC is the punishment for that crime.

- **191 IPC - Producing false evidence (Perjury).**
- **192 IPC - Fabrication of evidence.**
- **203 IPC - False information.**
 - Furnishing any false information.
- **202 IPC - Omission of information.**
 - Intentionally omitting the information even if the person is legally bound to inform.
- **197 IPC - Punishment for the issue-false certificate.**
- **198 IPC - Using a false certificate.**
- **201 IPC - Punishment for the disappearance of evidence.**
 - **Examples**
 - Removing blood stains from the crime scene.
 - Not sending viscera for toxicological analysis.
 - Embalming before the postpartum.

Negligence Causing Transmission of Disease (Fatal disease)

- **269 IPC - Negligence**
 - By negligence, transmitting any sexually transmitted diseases or HIV, that is transmission of any fatal disease by negligence.
- **270 IPC - Malignant**
 - Intentionally transmitting fatal disease.

Important Information

228(A) IPC

- **Disclosing the identity of the raped victim, punishable under 228(A) IPC.**
- **Punishment - Up to 2 years.**

Drug And Food Safety - Punishment

Trick 03: Drug and food have 4 alphabets.

- **272 IPC - Adulteration of food.**
 - liable for punishment.
- **273 IPC - Selling noxious food intentionally.**
 - Selling contaminated or adulterated food.
 - liable for punishment.
- **274 IPC - Adulteration of drugs intentionally.**
- **275 IPC - Selling adulterated drugs.**

Negligence Leading Poisoning

- **284 IPC**
 - **Negligence leading to poisoning** can be punishable under the IPC section 284.
 - **Example**

- In the bottle of milk, kerosene is filled instead of milk. If the baby consumes it then it comes under negligence leading to poisoning.
- If the bottle with nitric acid is not labelled, if someone consumes it, then it comes under negligence leading to poisoning.

Homicide

00:21:10

- Killing any human.
- **299 IPC**
 - A culpable homicide is defined under 299 IPC.
 - Culpable homicide can be of two types.
 - amounting to murder.
 - It is a culpable homicide amounting to murder defined under 300 IPC.
 - Not amounting to murder.
 - It is punishable under 304 IPC.

1. Culpable Homicide Amounting to Murder

- Act is done with intention or with knowledge.
- With the intention of causing death.
 - **Example:** A is firing on B and B is killed.
- With the intention of causing **bodily injuries, likely to cause death.**
- With the intention of causing bodily injuries, sufficient to cause death in the ordinary course of nature.
 - **Example:** Stabbing.
- Is committed with the **knowledge** that the act is imminently dangerous to life.

2. Culpable Homicide Not Amounting to Murder

- ACT is done causing death in.
 - **Provocation**
 - Example: If B abused A, then A fired on B and was killed.
 - **No motive**
 - **Self-defence**
 - **Judicial hanging**
 - Not punishable - Is decided by the court.
- Punishment comes under **304 IPC**-From 10 years to Life imprisonment.
- Punishment for murder (Culpable homicide) under **302 IPC** - Life imprisonment or death sentence.

Every murder is a culpable homicide, but every culpable homicide is not a murder.

Reason:

- There is some culpable homicide who are not amounting to murder.
- Not amounting to murder - It is the non-intention, no motive, but on provocation or self-defence.

303 - 309 IPC

- 303 IPC
 - Punishment for murder by life convict.

Trick 04: C is the third alphabet. So, 303.

- **S 304A IPC - A for Accident.**
 - Rash or negligent DEATHS.
 - Any rash or negligent acts causing death.
 - Medical negligence.
→ Punishment - 2 years ± Fine.

- **S 304B IPC - B for Bride (Bahu in Hindi).**
 - Dowry death.
 - Punishment - 7 years to life imprisonment.

prince kumar
princeeeekum@gmail.com
9928609733

- **S 305 IPC**
 - Abetment of suicide of child or insane person.

Trick 05

- In abetment, A and B are 1st and 2nd alphabet, if added becomes 3 i.e. alphabet C.
- E counts as a 5th alphabet, thus the IPC 305.
- **S 306 IPC:** Abetment of suicide for adults.

Attempt

- Attempt means the person survives after an attempt to murder that person.

Trick 06 - The ATTEMPT has 7 alphabets thus it starts from 307 IPC.

- 307 IPC - Attempt to murder.
 - It is punishable.
- 308 IPC - Attempt to culpable homicide.
 - It is punishable.
- 309 IPC - Attempt to suicide.
 - Is not punishable.

Criminal Abortion

Trick - 07

- In CRIMINAL - C is the 3rd alphabet.
- In ABORTION
 - A is the 1st alphabet.
 - B is the 2nd alphabet.
- Thus, the 312 IPC.

Trick 08

AB - Abandoning the child below 12 years of age.

C - Concealment of birth.

- **312 IPC -** With the consent of the mother.
- **313 IPC -** Without the consent of the mother.

- **314 IPC -** If there is a mother's death because of complications.
- **315 IPC -** Killing child or foetus about >28 weeks of gestation.
- **316 IPC -** The intention is to kill the mother, but the foetus gets killed.
- **317 IPC -** Abandoning the child below 12 years of age.
- **318 IPC -** Concealment of birth.



Important Information

- 312, 313, and 314 are related to criminal abortion or infanticide.

IPC and Important Law

00:34:53

- **I - Injury**
 - It is defined under **44 IPC**.
 - Injury is any illegal harm to four components.
 - **B -** Body injury,
 - Body injury is known as hurt.
 - **M -** Mind (Mental Injury),
 - **R -** Reputation
 - **P -** Property.

L - Life

- It is defined under **45 IPC**.

D - Death

- It is defined under **46 IPC**.

Hurt

- It comes under **319 IPC**.
- Whoever causes bodily pain, disease, or infirmity (kind of disability) to any person is said to cause hurt.
- Hurt is a type of body injury.

Grievous Hurt

- It comes under **320 IPC**.
- Any kind of severe hurt - Grievous hurt.

a. Emasculation loss

- Loss of masculine power.
- Loss of penis erection.
- Due to-
 - Cutting penis or genitalia,
 - Castration,
 - Spinal injury leading to loss of masculine power.

b. Permanent privation of the sight of either eye

- Visual impairment.

c. Permanent privation of the hearing of either ear

- Hearing impairment due to ossicles displacement or destruction.



Important Information

- After permanent privation of sight and hearing, if the surgery is performed and the vision and hearing got normalised.
- Even after getting the hearing and vision back, it is a grievous hurt.

Reason - It is artificial recovery but not natural recovery.

- d. Privation of any member or joint**
- Privation means lost, that is loss of any member or joint.
 - **Example:** Joint amputation (By someone).
 - **Member** - Any part of the body which has an independent function. Like.
 - Finger,
 - Nose,
 - Toe,
 - Ear or any part of the body which has its own function.
 - **Joints** like.
 - Wrist joint,
 - Shoulder joint, and
 - Elbow joint.
 - **Nail - Avulsion**
 - It is not a grievous hurt, it is hurt.
 - **Reason** - It is not the member of the body. It doesn't have any individual function.
- e. Destruction or permanent impairing of powers of any member or joint**
- f. Permanent disfiguration of the head or face**
- If they have any scar on the face and head after disfiguration - Grievous hurt.
 - Simply Vitriolage - Acid throwing on the head, and face.
- g. Fracture or dislocation of a bone or tooth**
- Even the hairline fractures come under grievous hurt.
- h. Any hurt**
- **Which endangers life - Dangerous injury**
 - It causes imminent danger to life.
 - Dangerous injury is a part of grievous hurt.
 - **Reason:** It affects the vital parts of the human body. Like.
 - Neck
 - Trachea
 - Blood vessels
 - **Example** - Heavy stone on the head, stabbing, cutting, firearm.

Important Information

- Every dangerous injury is a grievous hurt, but every grievous hurt is not a dangerous injury.

- **Which causes the victim to be in severe bodily pain.**
 - For 20 days or more.
- Or **unable to follow** his ordinary pursuits (Routine work - Eating, sleeping, walking, working, etc.) for a period of 20 days or more.

Hospitalisation for 21 days - Hurt.

Reason:

- Hospitalisation doesn't mean body pain or loss of routine activities.
- That indicates it is not a dangerous injury.
- Thus, if you didn't mention any of the above circumstances, then the hospitalisation is considered as HURT.

321 and 322 IPC

- **321 IPC** - Voluntarily producing hurt.
- **322 IPC** - Voluntarily producing grievous hurt.

Dangerous Weapon

- Cutting,
- Stabbing,
- Shooting,
- Firing,
- Explosion (Bomb Explosion),
- Poison,
- Weapon-Causing (Any weapon).

Important Information

- Animals are also weapons. Like.
 - Dog,
 - Snakes, etc.

Punishment for Voluntary Causing

- Hurt - 323 IPC.
 - **Punishment** - 1 year or ₹ 1000 fine.
 - **Example:** A is slapped by B.
- Hurt by dangerous weapon - 324 IPC.
 - **Punishment** - 3 years.
 - **Example:** A fired on B (Scratch).
- Grievous hurt - 325 IPC.
 - **Punishment** - 7 years.
 - **Example:** A punched on B (Fracture of tooth or bone).
- Grievous hurt by dangerous weapon - 326 IPC.
 - **Punishment** - 10 years.
 - **Example:** A stabbed B.
 - It is a grievous hurt with dangerous injury.

Trick 09

- 4-6 (Runs in cricket) - Dangerous Weapon is necessary.
- 328 IPC - Hurt by poison.

Trick 10

- **TORTURE** - T indicates 3.
 - It comes under 330 IPC.
- **331 IPC** - Hurt.
- **332 IPC** - Grievous Hurt.

Vitriolage

00:52:36

- Acid throwing.
- **Acid attack - 326A IPC.**
 - Minimum punishment - 10 years to life imprisonment.
- **Acid attempt - 326B IPC.**
 - Minimum punishment - 5-7 years.

01 On Provocation

- **Hurt - 334 IPC.**
- **Grievous hurt - 335 IPC.**

Trick 11

- **V - 319-328 IPC.**
 - Voluntary grievous hurt.
- **P - 334-335 IPC.**
 - Grievous hurt on provocation.
- **N - 336-338 IPC.**
 - Negligence.

02. By Rash or Negligence Act

- **336 IPC** - Endangering life on negligence.
- **337 IPC** - By negligence, if hurt is produced.
- **338 IPC** - By negligence, if grievous hurt is produced.

Assault

- **351 IPC** - Assault.
- It is the criminal force by which you produce fear in the opposite party, by.
 - **Gesture** (Raising voice, starring), or any,
 - **Preparation** (Bullet in the weapon, knife),
 - **Word** (Threatening).
- Examination of a patient by a doctor without consent - **351 IPC (Fear).**

01. Indecent Assault: Punishment

- This IPC is only for females.
- Doing indecency with females.
- **354 IPC** - **Outraging the modesty of females.**

Trick 12:

- The normal Descent order of numbers is 3, 4, 5.
- The Indecent order of numbers is 3, 5, 4.
- All indecent offences are cognizable (**Arrest without a warrant**).
 - **1st time** - **Bailable.**
 - **2nd time** - **non-Bailable.**

- The **354 IPC** is divided into.

- **S 354A IPC** - **Sexual harassment.**
 - Punishment is imprisonment of 1 year to 5 years with or without fine.
 - **Examples:**
 - Boss is showing indecency towards the secretary.
 - It may be by word or gesture.
 - Touching the buttocks.

Trick 13: There are a lot of as in the HARASSMENT.

- **S 354B IPC** - **Public disrobing.**
 - Removal of the clothes of females.
 - Punishment is imprisonment of 3 years to 7 years and fine.

Trick 14: There is B in Disrobing.

- **S 354C IPC** - **Voyeurism.**
 - Punishment is imprisonment of 1 year may extend to 3 years and fine, for repeat offence imprisonment of 3 to 7 years.

Trick 15: V for Watching (Sounding V) and V for Voyeurism.

- **Example:**
 - Watching nude or naked females.
 - Hacking world in sexual activity.
- **S 354D IPC** - **Stalking.**
 - Following a girl by any means either physical, telephone or mobile.
 - Punishment is imprisonment up to 3.

Kidnapping and Abduction IPC

01:02:15

- It is defined under **359 IPC.**
- **Kidnapping from India - 360 IPC.**
- **Kidnapping from lawful guardianship - 361 IPC.**
 - Male - Below 16 years.
 - Female - Below 18 years.
- **Abduction is defined under 362 IPC.**
 - **No age limitation** or above 18 years.
 - **Example:** On gunpoint taking one person from one place to another or confining someone in a place.
 - Abduction can lead to murder - **364 IPC.**
 - It is **punishable according to the intention.**
 - Want to kill someone - **364 IPC.**
 - Want to marry someone - **366 IPC.**
 - Producing grievous hurt.
- **Punishment - 363 IPC.**
 - **7 years** of punishment.

Important factors

- **Age**
 - Boy - Below 16 years.
 - Female - Below 18 years.

- **Lawful guardianship**
 - It matters in kidnapping not in abduction.
- **Forced, compulsion and deceitful means.**
 - Seen in abduction not in kidnapping.
- **Consent and intention**
 - Immaterial in kidnapping but very important in abduction.

Rape and Unnatural Sexual Offences

- **Defined** under **375 IPC**.
- **Punishment** under **376 IPC**.
- **377 IPC - Unnatural sexual offence.**
- **498(A) IPC - Cruelty by husband or in-laws' family.**
 - It can be physical or mental cruelty.
- **509 IPC - Insulting the modesty of women.**
 - Like - Staring, whistling.



Important Information

- **354 IPC - Outraging the modesty of women.**
- **510 IPC - Misconduct nuisance after drinking alcohol.**

Trick 16: After drinking alcohol everything gets doubled, like 5 becomes 10.



CROSS WORD PUZZLES



Crossword Puzzle

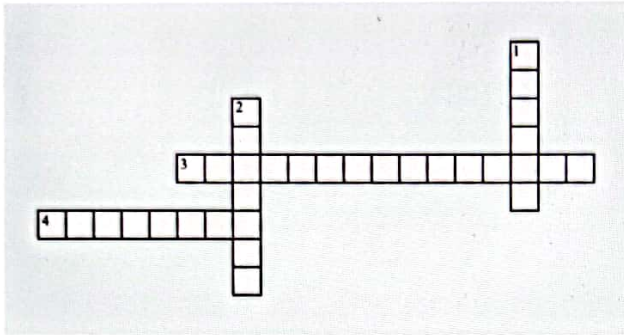

Across

- 3. Explosion (Bomb Explosion)
- 4. Killing any human

Down

- 1. Intention is to kill the mother but the foetus gets killed.
- 2. It is a part of Indian Contract Act

prince kumar
 princeeeekum@gmail.com
 9928609733



3 TORTURE

- Declaration of Tokyo-Guidelines for Medical Professionals (TO for Torture, TO for Tokyo)
- Istanbul Protocol - For examination of a torture patient (T for Torture, T for Turkey - place called Istanbul)
 - Dealing with torture patient
 - Dealing with torture victim
 - Reporting the injury
 - Documentation of the report
 - Intimate or inform to higher authorities.

Types of Torture

00:04:11

Important Information

IPCs to Remember for Torture - 2 Imp IPCs

- 330 IPC - Simple hurt caused by torture.
- 331 IPC - Grievous hurt caused by torture.

Dry Submarina

- Covering the face of the victim with a plastic bag, causes suffocation.



El Planton

- Forced standing/ prolonged standing - just as a plant stands for a long period.



Picana

- Picana - Electrical stimulation as torture.



Cattle Prod

- Electrical torture to the genital region.



Falanga/ Bestinado

- Beating of soles (most common method of torture)
- Mnemonic: F for Foot, F for Falanga

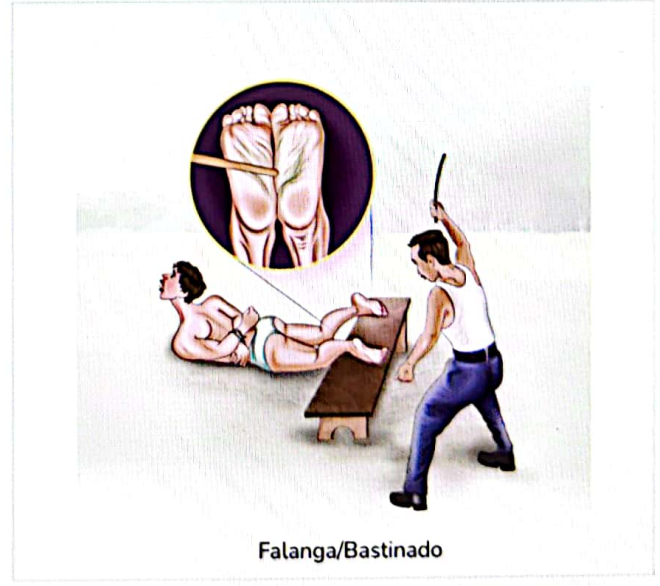

Telefona

- Repeated slapping of the sides of the head of the victim (usually ears).
- **Mnemonic:** T for Telephone (used at ears), T for Telefona (beating at ears).

**Black Slave**

- Insertion of a hot metal rod in anus.
- **Mnemonic:** B for Burn, B for Black Slave.

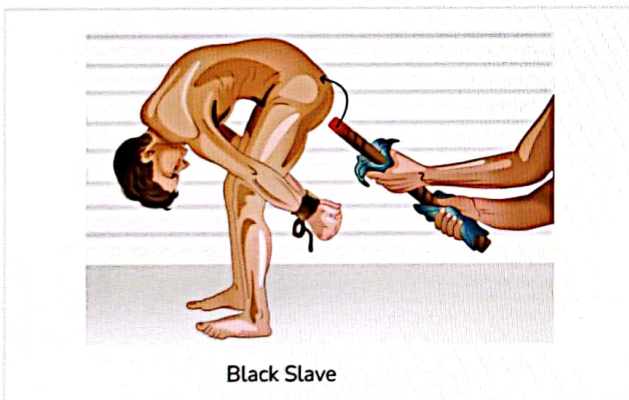
**Bellary**

- A stick smeared with red or green chili paste in anus.

Quirafino/ Operating table

- Hitting on abdomen

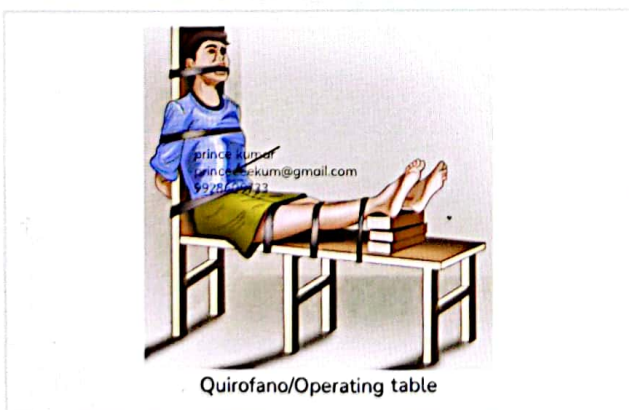
**Parrot Perch/ Jack**

- Suspending from a pole placed under the knees + wrist and ankle are bound together.

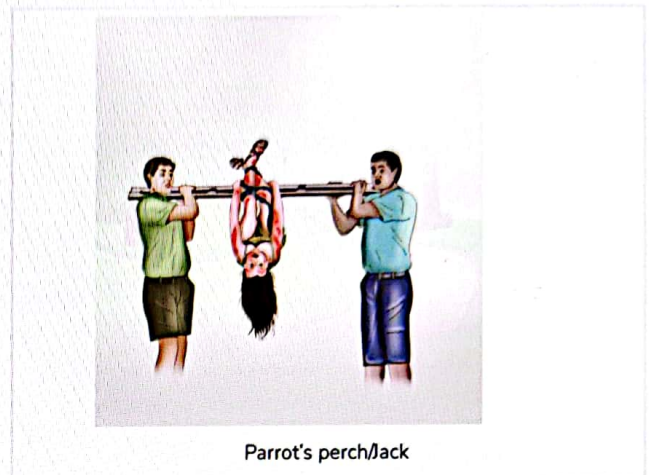
**Crucifixion**

- Crucifixion - Also called **Palestinian hanging**
- Neck comes forward causing positional asphyxia
- **Cause of Death** - Positional asphyxia

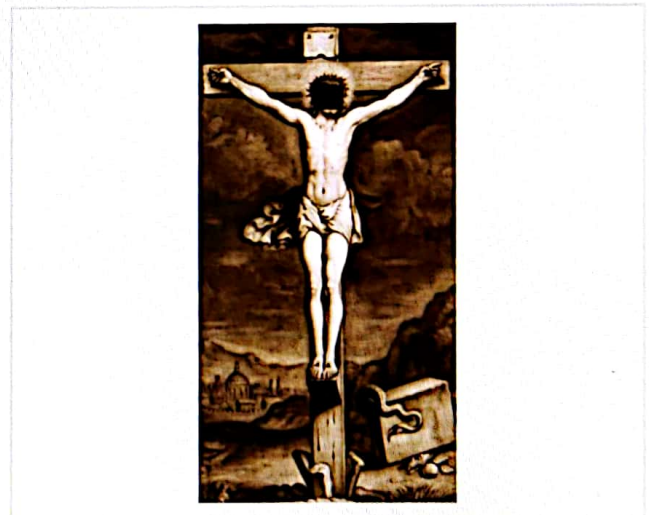
**Jack Knife Position**

- Chest and thigh come towards each other (chest is compressed for a long time).
- **Cause of Death** - Positional asphyxia

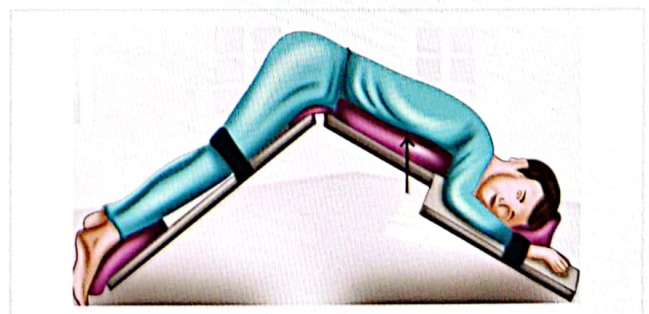

Belana

- Crushing of the soft tissue.
- Damaging the muscles of the legs and body by beating.
- Body is moved on a ridged surface - just like a belan (hindi - cylinder).

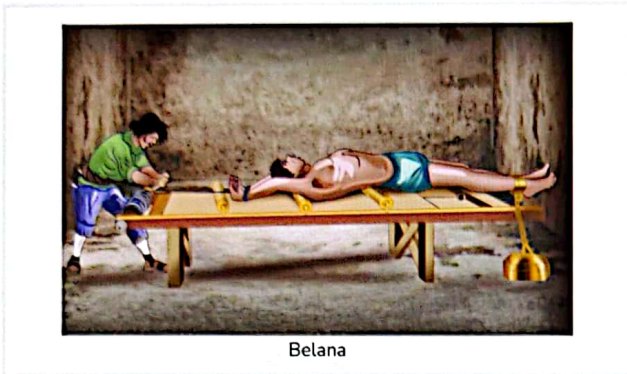

Belana

Caning

- A can is used to hit on buttocks.
- Commonly used in Singapore.

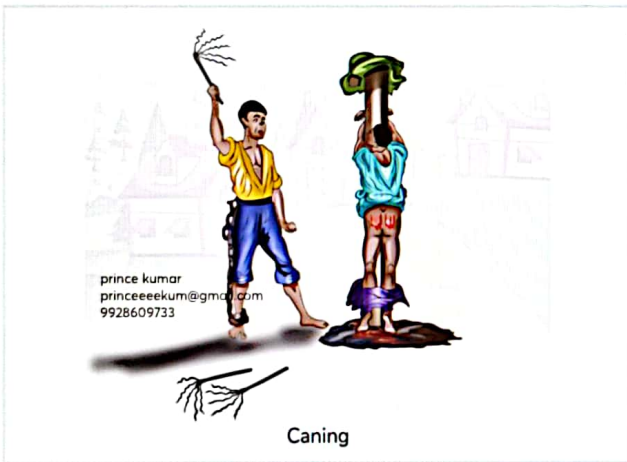

Caning

Passing on the Board

- Boards are used to hit on the body by laying down the victim on a table.
- Mostly used in China.



Passing on the board

Iron/Confession Chair

- Burning the body or using some burning method by tying the victim to a chair.
- Mostly used in China.

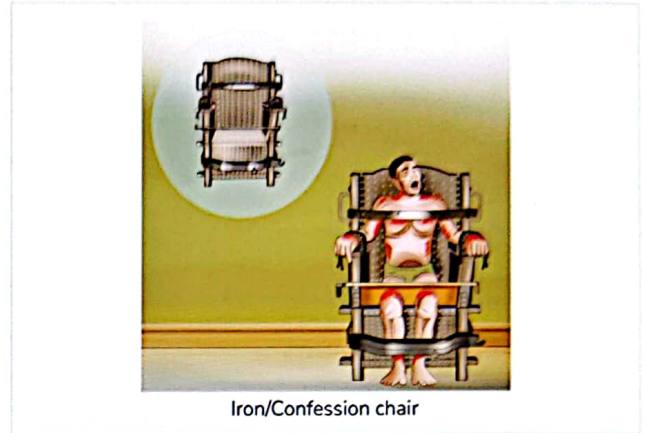

Iron/Confession chair

Saw Horse

- Forced posture on a sharp object (like saw)



Sawhorse

Chepuwa

- The legs and hands are tied very tight using bamboo sticks, and pressure is applied to induce severe pain.
- Mnemonic: Chepna (hindi)



Chepuwa

Wet Submarine

- Face is kept in a **wet area** (like water pot or bucket)

**Other Common Types of Torture**

- **Carotid restraints/ sleeper holds**
 - Pressure is put on the **lateral sides of the neck**.

- Carotid artery is blocked - leading to cerebral hypoxia that leads to temporary unconsciousness.
- **Chokehold**
 - Pressure is put on the **front side of the neck**.
 - Pressure on the throat - leads to choking.
- **Ghotna**
 - A wooden **pole is rolled up and down** the front of the thighs with one or more individuals standing on it.
 - **Mnemonic: Dal ghotni (hindi)**
- **La Bandera/ Strappado**
 - **Wrist is bound at the back** and the body is **suspended** on the wrist or the back.
 - Can cause **shoulder dislocation**.
 - **Cause of death: Brachial plexus injury**.
- **Murcielago**
 - **Suspended by ankle** (just as in La Bandera)
- **Dunking**
 - Victim is immersed in water and taken out for some time.
 - **Repeated** many times till the victim confesses.



CROSS WORD PUZZLES



Crossword Puzzle

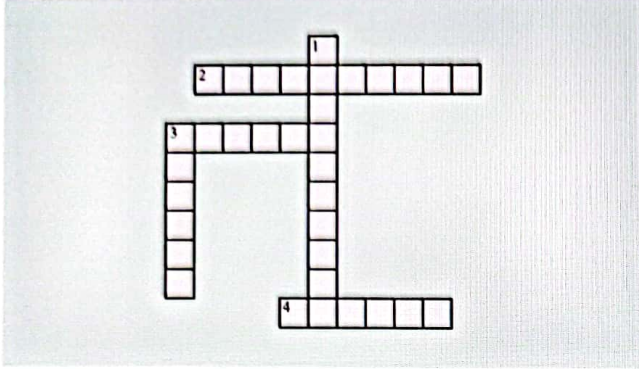

Across

- 2. Electrical torture to the genital region
- 3. Simple hurt caused by torture
- 4. Crushing of the soft tissue

Down

- 1. Insertion of a hot metal rod in anus
- 3. Grievous hurt caused by torture



4 COURT OF LAW

Court of law

- Doctors act as an expert witness at court because they make reports like postmortem reports, medico-legal certificates, and medico-legal document definitions

Important Definitions

IPC

- Full form: Indian Penal Code
- It was implemented in 1860.
- Total number of IPCs: 511

Included	Example
<ul style="list-style-type: none"> Most of the definitions are related to crime. Punishment of the crime 	<p>For example</p> <ul style="list-style-type: none"> What is murder? What is the punishment for the murder? What is rape? What is the punishment for rape?

CrPC

- Full form: Criminal Procedure Code
- It was implemented in 1973 and came into action in 1974
- Total number of CrPC: 184
- As the name suggests, it is the procedure for the punishment of the criminal.
- It includes.
 - Investigation: The police or investigating officer sends the warrant
 - Court proceedings
 - Summon
 - Judgment was given by the court

IEA

- Full Name: Indian Evidence Act
- Came into force in 1872.
- Number of IEA: 167
- Types of evidence
 - Oral evidence
 - Documentary evidence
- Every evidence will come under this act
- Even the procedure taking will also comes under this act

prince kumar
princeeeekum@gmail.com
9928609733

Type of Witness

00:05:19

Type of Witness	Description
Common Witness	<ul style="list-style-type: none"> It is the most common one It is also known as a layman witness. Perceived or observed a fact. It is a first-hand knowledge rule. Example of Eyewitness <ul style="list-style-type: none"> If A killed B, if you have seen the crime then you are considered an eye witness or common witness What you have seen or experienced you are delivering is known as the first-hand knowledge rule Common witness cannot be an expert witness
Expert Witness	<ul style="list-style-type: none"> He is a qualified or skilled or trained person. Examples of Expert witness <ul style="list-style-type: none"> Doctor Fingerprint expert Chemical examiner Explosive expert Firearm expert It comes under the 45 IEA. It is a volunteering of the statement. <ul style="list-style-type: none"> Saying facts voluntarily Expert witness can be a common witness

Important Facts of the IEA

It includes.

- Direct evidence
- Indirect evidence
- Hearsay evidence

Direct Evidence

- Direct evidence is evidence that is directly proved a fact.
- A person killed B, C has seen it (Direct evidence)
- The best example of direct evidence is.
 - Eyewitness

Indirect Evidence

- Collateral facts from which the inference may be drawn
- For example, A person has not seen the crime but he only saw a weapon in the hand of the patient.
- It is also known as corroborative evidence (Seen weapon in the hand of a person)



- **Circumstantial evidence:** Fingerprints of the accused at the crime scene
- The above both evidences are indirect evidence

Hearsay Evidence

- A person killed B, C has seen it and he or she came out of the crime and said to D that A killed B.
- This type of evidence is called hearsay evidence.
- Hearsay evidence is **not valid** in the Indian rule.
- **Dying declaration is valid** in case of the hearsay evidence.

Other Important Definitions Include

Plaintiff

- Plaintiff is a **victim**.
- If someone files a case then it is considered the plaintiff
- From the victim's side the witness is a **public witness**
- The public witness is also known as the **prosecution witness**.
- We have a lawyer known as a **public prosecutor**.

Defendant

- If you defend the case then you may be **defendent or accused**
- Accused is not a criminal it is on which we have an **accusation**.
- The witness from the accused side is known as the **defense witness**.
- We have a lawyer known as the **defense lawyer**.

Civil Case

- A case between the **two party**
- **Example:** Ram vs Sunitha like
 - Divorce case
 - The case of property dispute, and
 - The case of defamation

Criminal Case

- We use a word that is **against the government**.
- Crime is a crime (Described by the government law)
- Criminal case: **State vs X**
- **Example**
 - Rape
 - Murder

prince kumar
princeeeekum@gmail.com
9928609733

Cognizable Offences

- It is the offense where the police **arrest** the person **without a warrant**.
- This offense is a part of CrPC, and it comes under the **2 (C) CrPC**
- **Example**
 - **M:** Murder
 - **D:** Dowry death,
 - **R:** Rape, Ragging, Robbery
 - Rash and- Negligent act which leads to death.
 - Sexual offenses

Non-Cognizable Offences

- **Warrant is necessary** to arrest a person
- It comes under the **2 (L) CrPC**
- A simple hurt is an example of the non-cognizable offense

Ballable Offences

- You can get **bail** through the **police**.
- It come under **2 (a) CrPC**.

Non Ballable Offences

- In this offense **police cannot grant the bail**
- Whereas the **magistrate** can give you the bail
- It also comes under the **2 (a) CrPC**.

Compoundable Offences

- It can be settled by two parties **outside the court**.
- **Example:** Defamation case

Non-Compoundable Offences

- It **cannot be settled** by two parties **outside the court**.
- **Example**
 - Murder case
 - Rape case

Summon Cases

- In these cases the punishment or offense punishment is **less than 2 years**
- Warrant cases are those cases where offense punishment is more than 2 years.

Courts

00:25:00

It includes.

- Supreme court
- High court
- Session court
- Additional session court

Different Courts	Description
Supreme court	The biggest court in the country
High court	The biggest court in the state
Session court and Additional session court	<ul style="list-style-type: none"> • Biggest courts in the district • In case of using session judge, additional session judge you can use the word district judge
	<ul style="list-style-type: none"> • All the courts will charge unlimited fines • The judge can give a maximum sentence of the death sentence

Other Courts

- Assistant session court
 - It includes an assistant session judge
- Chief judicial magistrate (CMM/MM)
 - In metro cities, we can call a metropolitan magistrate.
- 1st class judicial magistrate
- 2nd class judicial magistrate
- **Fast track courts** are equal to session courts.
- All the punishments are given by the court come under the 53 IPC

Additional courts	Maximum punishment	Penalty
Assistant session court	10 years	Unlimited
Chief judicial magistrate (CMM/ MM)	7 years	Unlimited
1st class judicial magistrate	3 years	10,000
2nd class judicial magistrate	1 year	5,000

Juvenile Magistrate

- Juvenile is a child below 18 years of age.
- If the child committed a crime, then there is a juvenile magistrate.
- For this we have JJB known as Juvenile Justice Board
- It comes under the 1st class of judicial magistrate.
- Juvenile Justice Board has two social workers (One worker should be female)

Commutation of the Death Sentence

- Punishment given by the lower court, that punishment can be increased or decreased by the higher court is known as **commutation**.
- The court which passes the death sentence is a session court or additional session court

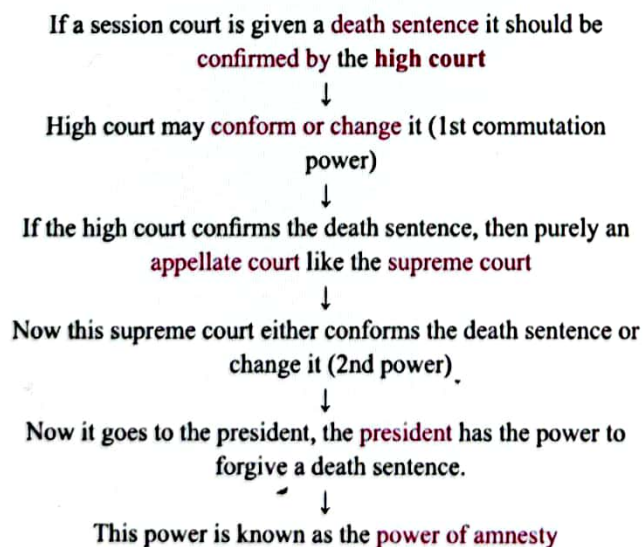

- 416 CrPC especially applicable for the pregnancy.
- If a **pregnant woman** is death sentenced, then the high court may change it to life imprisonment or **postpone the death sentence**.

prince kumar
princeenkum@gmail.com

Judicial vs Executive Magistrate

- It is of several types.
 - First-class judicial magistrate
 - Second-class judicial magistrate
 - Chief judicial magistrate

Judicial Magistrate	Executive Magistrate
These judicial magistrates are appointed by the high court	Executive magistrates are appointed by the state government
It includes. <ul style="list-style-type: none"> • First-class judicial magistrate • Second-class judicial magistrate • Chief judicial magistrate 	It includes. <ul style="list-style-type: none"> • District magistrate Other executive magistrates are: <ul style="list-style-type: none"> • Sub-divisional district magistrate • Additional district magistrate • Tehsildar • District collector

Inquest In India

00:35:52

- It is any type of investigation or inquiry into the **cause of death (COD)**
- It is held by **investigating officer (IO)**
- It would be the part of CrPC
- Two types of inquests
 - Police inquest
 - Magistrate inquest

Police inquest	Magistrate inquest
• CrPC for police inquest is 174	• CrPC for magistrate inquest is 176
• Investigating officer is the police	• Investigating officer is magistrate
The minimum qualification for police is <ul style="list-style-type: none"> • Head constable 	The magistrate can be. <ul style="list-style-type: none"> • Judicial Magistrate • Executive Magistrate

If a crime has happened

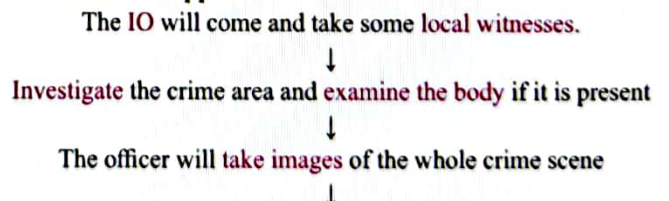

He takes evidence from the local witness known as **panchnama**

↓
This IO can be a police or magistrate

↓
Based on the evidence they make a report known as the **PANCHNAMA (Inquest report)**

↓
This IO will take the dead body to the doctor for **postmortem**.

↓
After the postmortem, the dead body will be handover to the IO

↓
This postmortem is known as the **medicolegal autopsy** in this consent of the relatives is not required

- The most **common** inquest is a **police inquest**
- The most **superior** one is the **magistrate inquest**.
- Magistrate is also helped by the police in the magistrate inquest.
- PANCHNAMA is a hindi word.
- After postmortem body will be handover to the IO not to their relatives
- **Police** conduct the inquest in case of
 - Unnatural death (Not due to a disease)
 - Examples
 - Accidental case
 - Suicide cases
 - Homicide case
- **Magistrate** inquest in case of **infuse-specific death**.
 - Mental Asylum
 - Police Beating and Borstals
 - Police Custodial Death
 - Dowry Death (If any married woman died within seven years of marriage and there is an allegation)
 - Exhumation (Digging the dead body out)
 - Police Firing (Death occurred due to police firing)
- **Judicial Magistrate** inquest
 - Police Beating Death
 - Police Custodial Death
 - Police firing Death.
- Other than the above three all others are investigated by the **executive magistrate**

Inquest Not in India

It is of two types.

- **Coroner inquest**
 - It was present in Mumbai until 1999
 - After that it has been demolished
 - It was based on the **jury system**.
- **Medical examiner inquest**
 - It is the **best inquest system**.
 - It is present in **developed countries**.
 - The person who inquest is a **medical examiner**.

prince kumar
princeekum@gmail.com
9928609733

Q1. Which is the overall best inquest system

Answer: Medical examiner inquest

Court Procedure (Evidence)

00:48:06

- It is because **the witness gives the evidence**.
- It includes.
 - Summon
- **Other Name:** Subpoena (Sub: Under, Poena: Penalty)
- **Summon** is a document given to the witness.
- In this document time, date, and place are mentioned.
- After giving this form if the witness has not come to the court, then the witness should pay the penalty. Hence it is known as **Subpoena**.
- Summon/Subpoena is classified into **two**.
 - **Subpoena AD Testification**
 - AD: Attend
 - Testification: Give evidence.
 - It is used for the **common witness**.
 - **Subpoena Duces Tecum**
 - Duces: Document
 - Tecum: Take the report to the court.
 - It is used for the **expert witness**.

How to Attend the Summon and Punishment for not Attending

- Punishment for not attending the court is **IPC 174**
- It is **6 months imprisonment or thousand rupees penalty or both**.
- Things to know before attending the court.
 - First see whether the court is civil or criminal.
 - Preference has to be given to the criminal case like Rape, Murder
 - You need to send the application to the civil court for permission or requisition for attending the criminal court.
 - If you got two summons and both are in criminal courts then.
 - Select the higher court rather than the lower court.
 - If the court has the same level
 - Then attend to the summon which has been received first.

Oath

- It is **compulsory** under **51 IPC**.
- **Refusal of oath** comes under **178 IPC**.
- Punishment includes **6 months imprisonment or thousand rupees penalty or both**.
- **Age limit:** Below 12 years of old oath is not needed.
- If we believe the god, then we take the oath in the name of god **"I do swear in the name of God."**
- Whatever I shall speak it will be truth.
- It should be **whole truth**.
- Nothing but the truth

A person who doesn't believe the god (Atheist)

- "I do solemnly affirm that."
 - Whatever I shall speak it will be truth
 - It should be whole truth
 - Nothing but the truth

3 IPC For Evidence Punishment

- 193: False evidence
- 197: False document
- 201: Disappearance of evidence

Other IPCs

- 191: After taking the oath of your giving false evidence
 - It is known as **Perjury**.
 - Perjury is defined under **191 IPC**
- 192: Fabricating the evidence
 - Changing the document
 - It is defined under **192 IPC**.
- 193: For both false and fabricating the evidence
 - It is defined under **193 IPC**.

prince kumar
princeeeekum@gmail.com
9928609733

Q2. For fabricating the evidence or false evidence the punishment comes under which IPC

Answer: 193 IPC

Examination of the Witness

- The below sequence is based on the 138 IEA act.

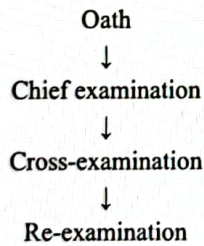

- Chief examination - same-party lawyer
- Cross examination - opposite party lawyer
- Re-examination - same party lawyer

Prosecution Witness vs Defense Witness

Examination of the Witness	Prosecution witness	Defense witness
Chief examination	The same party is a public prosecutor	Defense lawyer
Cross-examination	Defense lawyer	Public prosecutor
Re-examination	Public prosecutor	Defense lawyer

Leading Questions and Hostile Witness

Leading Questions

- Leading question is a question where the answer is **yes or no**.
- For example
 - Was Sita wearing a black dress?
- Leading questions are asked only in **cross examination**

Hostile Witness

- Hostile witness is a witness who is **contradicting the statement**.
 - Not favoring your prosecution side
- Leading questions can be asked in chief and reexamination.
- This is based on the **154 IEA**

Important Acts of IEA

01:08:46

Acts	Explanation
138	The sequence of examination (Oath CH CR RE)
141	Definition of a leading question
142	In chief examination and re-examination, leading questions are not permitted
143	Leading questions are allowed in cross-examination
154	In chief examination and re-examination, leading questions are permitted (Hostile Witness)
165	A magistrate or judge can ask you a question at any point of time

Conduct Money

- It is a kind of **Diet of Money**
- Money is **paid for the witness** to meet the expenses for attending the court.
- Conduct money is paid in case of **civil cases**.
- It is paid by the party.
- The conduct is decided by the court.
- Money can also be paid for criminal cases by only an **expert witness**.
- This money is paid and **decided by the court**.
- For example, traveling allowances are given for expert witness.

Exceptions for Oral Testimony

- After the oral testimony, documentary evidence is accepted. But there are some exceptions in which **only documented evidence is valid**.
- The exceptions include.

- Dying declaration (DD)
- Expert opinion expressed in a treatise/textbooks.
- Evidence of a doctor recorded in a lower court.
- Reports of certain government scientific experts like chemical examiner, chief inspector of explosive serologists, etc
- Evidence given by a witness in a previous judicial proceeding.
- Public records
- Hospital records

Dying Declaration vs Dying Deposition

Dying Declaration	<ul style="list-style-type: none"> • It is followed in India. • It is the statement given by the dying patient. • This statement can be a <ul style="list-style-type: none"> ○ Oral statement ○ Document • It is based on the 32 IEA. • The declaration can be given by <ul style="list-style-type: none"> ○ Victim ○ Magistrate ○ Doctor ○ Police ○ Any person • Not Recommended <ul style="list-style-type: none"> ○ Oath ○ Cross-examination ○ Leading questions
--------------------------	--

Dying Deposition	<ul style="list-style-type: none"> • It is followed in developed countries. • It occurs in the presence of the <ul style="list-style-type: none"> ○ Magistrate ○ Defense lawyer • Recommendations <ul style="list-style-type: none"> ○ Oath ○ Cross examination is done (Best to protect the accused) ○ Leadings questions are asked
-------------------------	---

These are valid only when the person dies

- **Oral evidence** is better than documentary evidence.
- In oral evidence there is a **chance for the cross-examination**

Some Important Laws

- Res Gestae is under the section **6 IEA**.
- Res Gestae (Section 6 IEA) are acts (Involuntary exclamations) made at the **time of offense** (Was committed) and are so closely **connected to the main fact** (heat of the moment)
- Dying declaration (**32 IEA**)
- Expert witness in the form of travel allowance (TA) and dietary allowance (DA) as per the government's rule (**312 CrPC**)
- Court may issue a notice under **350 CrPC**, if it finds that the **witness neglected** to attend the court without any justification.
- Recall and re-examination of witness is under **311 CrPC**
- A death sentence can be commuted to life imprisonment if the woman is pregnant (**416 CrPC**)
- **Paula Zacchias** is considered as **Father of Legal Medicine**
- **141 IEA** - Leading question
- **137 IEA** - Chief EXAMINATION
- **145 IEA** - CROSS Examination
- **118 IEA** - No age limit for testifying the court.
- **119 IEA** - **Dumb witness** can give the evidence by writing or signing in open court.
- Age limit of taking the oath is below 12 years.



CROSS WORD PUZZLES



Crossword Puzzle

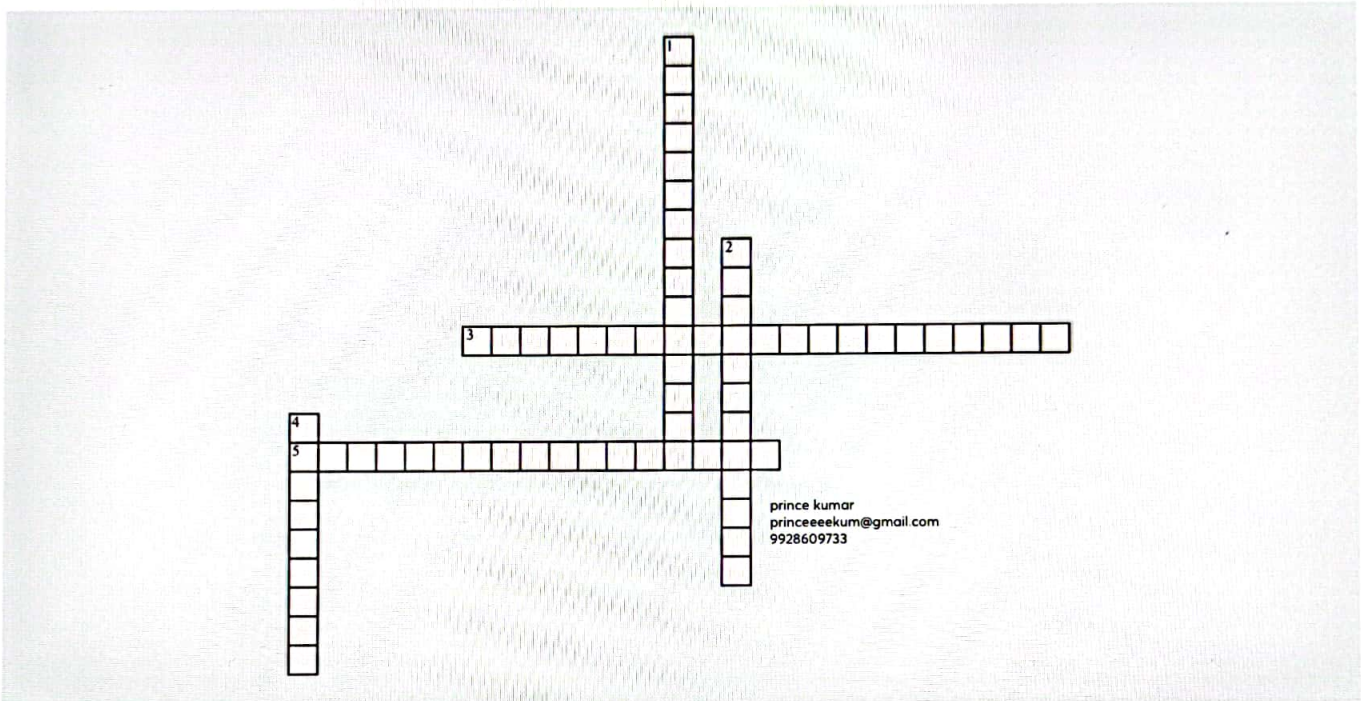

Across

- 3. It was implemented in 1973 came into action in 1974
- 5. Came into force on 1872

Down

- 1. IPC
- 2. Biggest court in the country
- 4. Biggest court in the state



5

TRACES OF EVIDENCE

- Important in the examination of crime scenes.
- Examples of evidence
 - Bloodstain
 - Seminal stain
 - Hair sample
- **Edmond Locard**, a French criminologist is considered as the **Father of Forensics**.
- **Important contributions of Locard**
 - **Poroscopy** - Used in the identification.
 - **Locard Exchange Principle** - Important in crime scene examination.

What is the Locard Exchange Principle?

- When two things come in contact there is always an exchange of materials from one to another.
- **Example:** A criminal commits a crime, he/she leaves some traces like blood, semen, and hair sample at the scene.

1. Blood Stains

00.04.06

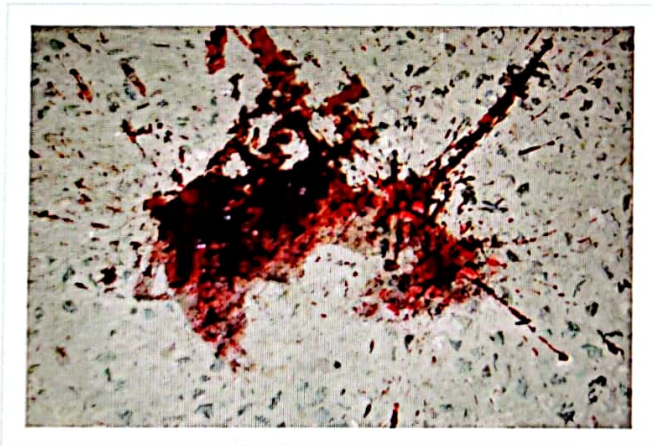

A. Screening Tests

- Every blood stain has **peroxidase activity**.
- Screening tests are performed based on peroxidase activity.
- Screening tests are also called **Presumptive tests**.

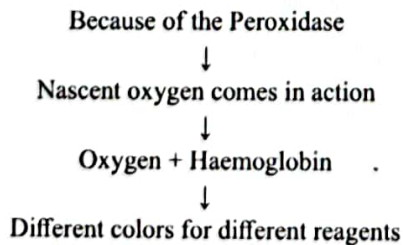

Different Screening Tests for Blood Stains (Questions might be asked)

- Tests based on Peroxidase enzyme activity.

Test	Color
Benzidine test	Blue
Phenolphthalein test/ Kastle-Mayer test	Pink
Orthotolidine test	Blue
Leucomalachite test	Peacock blue

Benzidine test

- **Most sensitive test**
- Very good to detect old blood stains.
- **Problem** - Benzidine is a carcinogen.
- There are few things which give **false + ve results** for Benzidine test.
 - Milk
 - Plant juices
 - Pus
 - Saliva
 - Few bacteria (peroxidase +ve)

prince kumar
princeeeekum@gmail.com
9928609733

Q1. Which is the most sensitive test in blood stain screening?
Ans. Benzidine test

Other screening tests

- **Luminescence test** - Luminol spray and UV rays are used.
 - Required if blood stain is invisible or old/washed stain.

B. Confirmatory Tests

i. Microchemical Tests

Test	Crystal & Color
Teichmann test	Brown rhombic crystal color (A dark brown man)
Takayama test	Pink feathery crystal (Takatak is pink)

ii. Spectroscopy Tests

- Gives bands.
- Most specific confirmatory test.

Q2. Which is the most sensitive test in blood stain confirmation?
Ans. Spectroscopy test.

iii. Microscopy

- Differentiation between human and animal blood.

Animal Blood (RBC)	Human Blood (RBC)
Oval	Round
Convex	Concave
Nucleus +ve	Nucleus -ve

• **Teichmann test**

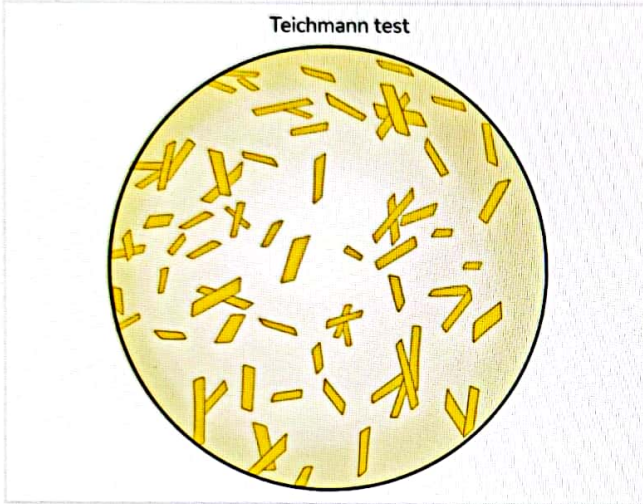

- **Appearance:** Brown rhombic dark crystals are seen.
- **Chemicals used:** NaCl + GAA (Glacial acetic acid).
- **Mnemonic:** Men are brown, Teichmann has 'man', thus 'brown rhombic dark crystals'.
- **Type of crystals:** Hemin Cl crystals/ Hematin Cl crystals (like Heman and also NaCl is used).

• **Takayama test**

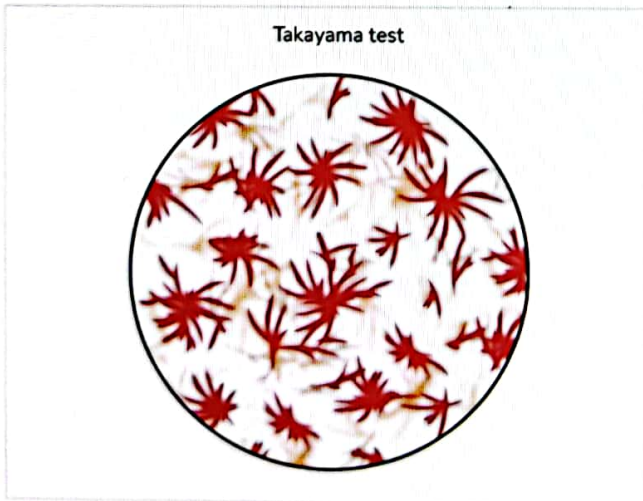

- **Appearance:** Pink feathery crystals.
- **Chemicals used:** GPS (Glucose + Pyridine + NaOH)
- **Mnemonic:** Takatak is pink color.
- **Type of crystals:** Hemo-chromogen crystal.

To Remember: The test which can give the species differentiation is the **Precipitin test**.

2. Semen Analysis

00:16:38

- Usually found in rape and unnatural sex cases.
- Semen constituents
 - 10% - Sperm
 - 90% - Seminal fluid

A. Florence Test

- **Detects -** Choline crystals (Dark brown rhombic crystals)
- **Reagent -** KI is used.
- **Mnemonic:** Florence has 'C', C for Choline.
- **Type of crystals:** Choline iodide.

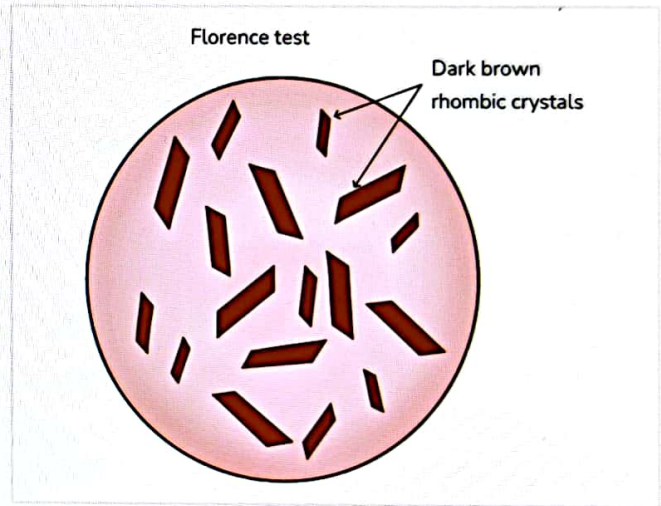

B. Barberios Test

- **Detects -** Spermine crystals (yellow needle-shaped crystals)
- **Reagent -** Picric acid.
- **Mnemonic:** Barbar picks your hair with a needle.
- **Type of crystals:** Spermine Picrate.

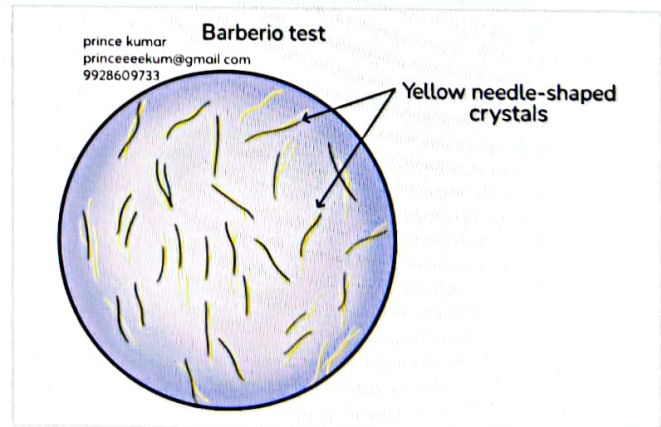

C. Other Tests for Semen Analysis

- **Fluorescence test:** Seminal stain + UV light → **Bluish white color**.
- **Acid phosphatase test**

- o Positive even in the cases of Aspermia (absence of sperms)
- o **Normal range:** 320-360 Bodansky unit
- **CPK (Creatinine Phospho Kinase)**
 - o **Mnemonic:** CPK - Old (Pakahua - means old in Hindi).
 - o Detects: Old seminal stains (6 months old as well)
 - o **Normal range:** 660 IU/ml.
- **Ammonium molybdate test** - Detects Phosphorus content of Semen.
- **Ag tests**
 - o **Glycoprotein P30 test:** Prostate Specific Ag (PSA)
 - o **MHS-5:** Seminal vesicle-specific Ag
 - o **MAB-4eb:** Sperm specific Ag
- **LDH isoenzyme detection of sperm**
 - o Most specific test of semen
 - o Absolute proof = One unbroken sperm.
- **Phadebas test** - In case of oral sex, saliva can be detected by L-amylase.

To Remember

- **Barberios test**
 - o Presence of Spermine (from the prostate) is detected.
 - o Gives yellow needle-shaped crystals of Spermine Picrate.
- **Florence test**
 - o Presence of Choline (from the seminal vesicle) is detected.
 - o Gives dark brown rhombic crystals of Choline iodide.

3. Hair Analysis

00:25:14

- Study of hair - Trichology.

Q3. What is the growth rate of human scalp hair?

Ans. 0.44 mm/day

- Hair is significant in the detection of many things like
 - o DNA
 - o Bar body
 - o Race of a person
- **3 parts of the hair**
 - o Root
 - o Shaft
 - o Tip

Why is hair very important in Forensic medicine?

There are many instances.

- Burned trauma - Singeing of hair (curled or twisted hair).
- Sharp trauma - Cut hair (end of the hair is cut).

- **Blunt trauma** - Crushed hair (blurred or irregular margin).
- **Cross section of hair**
 - o Cuticle (imbricate scales)
 - o Cortex
 - o Medulla

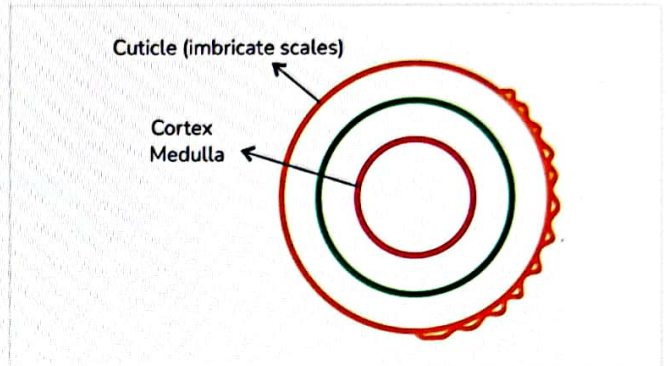

- Outermost - Cuticle (imbricate scales)
- Middle - Cortex
- Innermost - Medulla.

Human vs Animal Hair

Animal Hair	Human Hair
Medulla is thick.	The cortex is thick.
Coronal scales (C for Cattle, C for Coronal)	Imbricate scales (I for Insane means human in Hindi, I for Imbricate)
Coarse and thick	Fine and thin
Continuous Medulla	Narrow Medulla
Pigment is at the Center.	Pigment is at the Periphery.
Medullary index (MI) is more (>0.5)	Medullary index (MI) is less (0.33 or less)

$$\text{Medullary index (MI)} = \frac{\text{Diameter of medulla}}{\text{Diameter of entire hair}}$$

- Confirmation of species is done by Precipitin test.

Other Important Information

- **Alec Jeffreys** - Father of DNA analysis or DNA fingerprinting.



- **DNA fingerprinting** is the best test for paternity/ maternity disputes.
- **Other tests** like HLA typing and Blood grouping are also used.

Q. Which is the best test for blood grouping?

Ans. Modified acid elution test/ acid elution test.

- **Important tests to remember:** Teichmann test, Takayama test, Florence Test, Barberios Test.

princeeeekum@gmail.com
9928609733



CROSS WORD PUZZLES



Crossword Puzzle

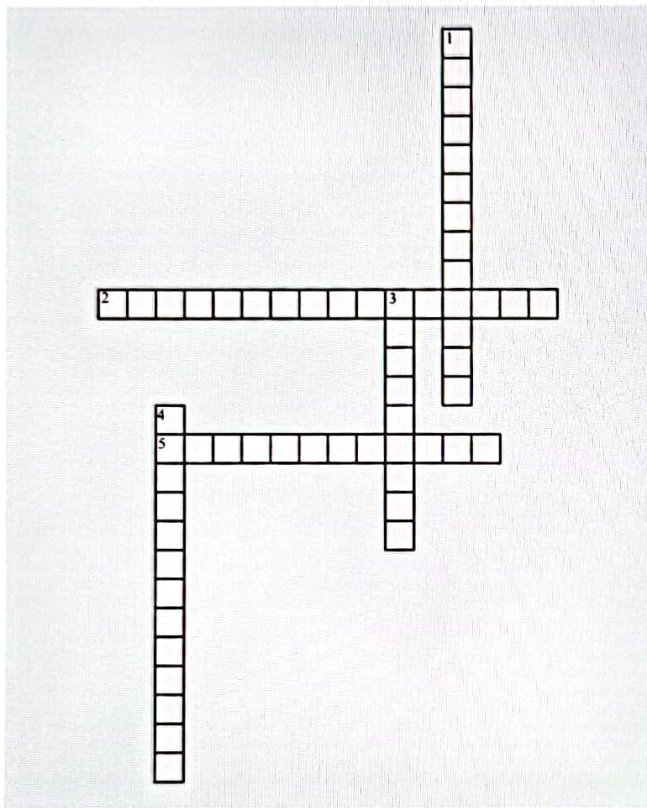

Across

- 2. sensitive test in blood stain confirmation
- 5. Father of Forensics

Down

- 1. sensitive test in blood stain screening
- 3. Used in identification
- 4. Brown rhombic crystal color (A dark brown man)

prince kumar
 princeeeekum@gmail.com
 9928609733



6 SEXUAL OFFENSES

4 types

- Natural (peno-vaginal route)
- Unnatural (non peno-vaginal route)
- Sexual perversions (Paraphilia)
- Sex-linked offenses (voyeurism, stalking)

1. Natural

Mnemonic: RIA

- **Rape**
 - Forcefully
- **Incest**
 - Sexual relationship between blood relations
 - Not a crime in India
 - No IPC for Incest
 - **3 complexes**
 - **Electra**: Daughter and father (DEF)
 - **Oedipus**: Son and Mother (O+O)
 - **Pharaon**: Brother and sister
- **Adultery**
 - Extramarital affairs.
 - Decriminalized in India.
 - Civil case
 - Strong ground for divorce
- **2. Unnatural - IPC 377 (Unnatural)**
- **Anal/ Greek love/ Sodomy/ Buggery**
 - Can be between male-male and male-female.
 - Active agent (adult) - Pedarast
 - Passive agent
 - **Child** - Catamite (Pedarasty)
 - **Old** - Gerontophilia
- **Oral/ Mouth/ Coitus per os/ Sin of Gomorrah**
 - Mainly done with child
 - **Fellatio** - Oral stimulation of male genitalia
 - **Cunnilingus** - Oral stimulation of female genitalia
- **Animal sex/ Bestiality**
 - Lower animals are involved.
 - Usually, human sperm is found inside animals.
- **Lesbianism/ Sapphism/ Tribadism**
 - **Active agent** - Butch/ Dyke
 - **Passive agent** - Femme
 - **Mnemonic**: BDF

Punishment Under 377 IPC

- **Minimum 10 years**
- Punishment is given only when there is no consent taken.
- If minors (<18 years) are involved then punishment is inevitable.

To Remember

- Sodomy/ Unnatural sex with 18+ and with consent - No 377 IPC
- Bestiality - Always 377 IPC

Medical Examination in Sodomy

- **Active agent**: Same as rape cases.
- **Passive agent**: **Knee-Elbow Position** (Anal canal/ Rectal canal/ Perianal area)

Non-Habitual Passive Agent	Habitual Passive Agent
<ul style="list-style-type: none"> • Pain/ tenderness is present. • Fresh or dried semen in the anus or perianal area (depends on duration) • Perianal injuries + tenderness <ul style="list-style-type: none"> ○ Abrasions ○ Contusions ○ Lacerations • Fresh bleeding or dried blood stains may be present. • Tyre sign is seen in forceful sodomy - Loss of skin fold in the perianal region due to hematoma. • Digital examination is obsolete. 	<ul style="list-style-type: none"> • No pain/ tenderness • Perianal hair is shaved. • Absorption of perianal fat with funnel-shaped depression of anus • Perianal skin is thickened and keratinized. • Dilation of the anus with loss of mucosal rugosity • Prolapse of rectal mucosa • Lateral buttock traction test: Paradoxical dilatation of anus during bimanual traction of buttocks

Rape - 375, 376 IPC

00:18:56

- Both natural and unnatural
- **375** - Definition
- **376** - Punishment

Definition - IPC 375

- A man is said to commit rape if he penetrates his penis or penis-like object/ body part,
 - Vagina
 - Oral cavity
 - Anal canal
 - Urethra

Conditions

- Against her will
- Without her consent (**will**)

To Remember

- Will - With your heart
- Consent - Yes, but without heart
- With her consent, if the consent is obtained by putting her in fear of death or hurt.
- Impersonation (as husband)/ fraud (telling himself unmarried for consent, even if the person is married)
- Intoxication/ insane (influence of drug or alcohol) - 90 IPC discussed in Forensic Psychiatry
- With or without her consent when she is under 18 of age.

To Remember:

Even if a girl gives consent below 18 years, it is known as statutory rape.

- Unable to communicate the consent.

The Quick Pills

- The slightest penetration of the penis within the vulva (labia majora) or other, with or without emission of semen or rupture of hymen constitutes rape.
- Hymen rupture can never decide a rape.
- Under the law rape can only be committed by a man, and a woman cannot rape a man (except in France where even a female can be charged with rape)
- Females can be charged with gang rape.
- In India, there is no age limit under which a boy is considered physically incapable of committing rape.
- Minimum age for giving consent for sex is 18 years.
- Medical proof of intercourse is not legal proof of rape.

To Remember

- Legal proof - Consent
- Medical proof - Sex
- Medical interventions are not rape (with consent)
- POCSO Act - Protection of Child against Sexual Offense (applicable if a <18 years is involved)

Punishment of Rape - IPC 376

- **Subsection-1**
 - Punished with rigorous imprisonment for a term which shall not be <7 years.
 - May extend up to 10 years or life imprisonment.
 - also be liable to fine.
- **Subsection-2**
 - For the serious form of rape as described below.
 - Punished with rigorous imprisonment for a term which shall not be <10 years.
 - May extend up to life imprisonment.
 - This punishment is for rape by a
 - Police officer (police custody)
 - Member of arm forces
 - Management or staff of the jail
 - Management or staff of the hospital

- Relative
- Guardian
- Teacher
- Communal violence
- Rape on,
 - Pregnant women
 - Insane people having physical or mental disabilities
 - People who are incapable of giving consent
 - <18 years
- Committed rape repeatedly.
- Causing grievous bodily harm or endangering life.

To Remember:

Imprisonment for life in subsection-2 of IPC 376 is up to natural life.

- **Subsection-3**
 - Girl <16 years
 - Minimum 20 years imprisonment, which can extend up to life imprisonment.

Extensions in IPC 376

- Made after the Nirbhaya case

Refer Table 6.1

Major changes proposed in criminal law (amendment) act, 2018

Age of woman	Offence	Section of IPC	Criminal law (amendment) act, 2018
Below 12 years	Rape	376 AB	Minimum: 20 years Maximum: Life imprisonment or death
	Gang rape	376 DB	Minimum: Life imprisonment Maximum: Life imprisonment or death
Below 16 years	Rape	376 (3)	Minimum: 20 years Maximum: Life imprisonment
	Gang rape	376 DA	Minimum: Life imprisonment Maximum: No provision
16 years and above	Rape	376	Minimum: 10 years Maximum: Life imprisonment

- Mnemonic: 12 - AB, 12 years 376 AB

Other Sections

00:39:00

IPC 228

- **228A IPC:** Whoever revealed the identity of the victim of rape (punishment is imprisonment extending to two years).
- There are few exceptions,
 - If it is for investigation purposes.

- o Victim is authorizing.
- o Printing or publication of the judgment of any High court or the Supreme Court

IEA 114

- Presumption of the absence of consent.
- If the victim says that she did not consent it is presumed

To Remember:

The burden proof for rape is always on males.

IEA 146

- Questions for the general immoral character during cross-examination are not permitted.

327(2) CrPC

- Camera trail
- Closed courtroom proceedings.

357C CrPC

- Provide first aid or medical treatment free of cost, to victims of rape or vitriolage, and inform the police.
- If violated, can be punishable under 166B IPC.
- Punishment is 1 year with or without a fine.

164A CrPC - Examination of Victim of Rape/Attempt

- Request for the examination can be made by any police officer within 24 hours
- Consent of women for examination is a must and should be examined under the supervision of female RMP (S 53 (2) CrPC)
- **How to examine a rape victim?**
 - o Ask her to remove their clothes.
 - o Examine the clothes and collect the evidence.
 - o Collect the foreign hairs, seminal stains, and other stains if present.
 - o Search for physical injuries
 - o Toluidine-blue contrast is applied to detect fresh micro injuries over anogenital area.
 - o **4 swabs**
 - Smear
 - Making a smear
 - Examination under microscope
 - Sperm
 - Saline is used.
 - Motility of sperm is tested.
 - DNA profiling
 - Chemical test
 - Acid phosphatase
 - Creatinine phosphokinase
 - Lactate dehydrogenase
 - o Examine in lithotomy position in good light.

- o Glaister-keene rods or **hymenoscope** is used for the examination of a hymen. Tearing usually occurs posteriorly at the sides, between 5 and 7 O'clock position.
- o Speculum is used for examination of the vagina.
- o Colposcope is used for examination of the cervix.
- o Treat STDs, injuries, or pregnancy
- o Provide psychology support.

S 53(1) CrPC-Examination of Accused with Reasonable Force

- Request for the examination should be made by SI and above.
- 54 CrPC - examination of accused under by his request.
- **General examination**
 - o Behavior
 - o Mental status
 - o Clothes
 - o Hair (female hair)
- **Genital examination**
 - o Semen
 - o Sperm
- **Smegma** at corona glandis and under foreskin of glans
 - o Present for 24 hours only.
 - o Can be rubbed off and show -ve results.
- Examine the penis and glans for **vaginal cells**
 - o Papanicolaou's stain
 - o Lugol's iodine

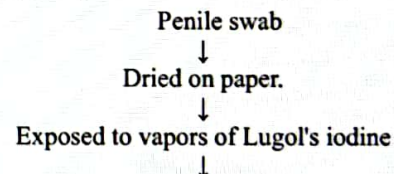

Brown if vaginal cells present (presence of glycogen)

To Remember:

Lugol's iodine can be done till 4 days after rape

SAFE Kit-Sexual Assault Forensic Evidence Kit

- Used both for the victim and accused.
- **Contents**
 - o Bags and sheets for evidence collection.
 - o Swabs for collecting fluids from the,
 - Lips
 - Cheeks
 - Thighs
 - Vagina
 - Anus
 - Buttocks
 - o Clear glass slides
 - o Self-sealing envelopes for preserving the victims.
 - Clothes
 - Head hair
 - Pubic hair
 - Blood samples
 - o Nail pick for scraping debris from beneath the nails

- White sheets to catch physical evidence stripped from the body
- Documentation forms
- Labels
- Sterile water and saline

3. Sexual Perversions

- **Another name:** Paraphilia
- Abnormal act to get sexual gratification.
- No sex

Types

- **Sadism/ algolagnia:** Getting satisfied by giving **pain to a partner**.
- **Masochism/passive algolagnia:** Getting satisfied by receiving **pain from a partner**.
- **Bondage:** sadism + masochism
- **Lust murder:** Murder serves as a stimulus for a sexual act
- **Urolagnia/Undinism/urophilia:** Urine smell or, touch and sight
- **Uranism:** Sexual gratification by fingering, fondling, licking, sucking of genitalia of opposite sex.
- **Coprophilia:** Fecal smell and touch

- **Sexual oralism**
 - **Feliatio:** Oral stimulation of male genitalia
 - **Cunnilingus:** Oral stimulation of female genitalia

- **Exhibitionism**
 - Showing private parts
 - Punishable for **3 months under 294 IPC**
 - It has following,
 - **Steaking:** Running naked in a public place
 - **Mooning:** Showing the bare buttocks (**Mnemonic:** Moon is just like buttocks)
 - **Flashing:** Momentarily exposing body parts by quickly moving the clothing (**Mnemonic:** Just like a flashlight)

- **Necrophilia and Necrophagia**
 - **Necrophilia:** Sex with a dead body
 - **Necrophagia:** Eating dead body parts.
 - Punishable under **297 IPC up to 1 year**

To Remember:

Any kind of disrespect to a dead body comes under 297 IPC.

- **Transvestism**
 - **Another name:** Eonism
 - Common in male
 - Wearing clothes of the opposite sex

- **Fetichism**
 - Common in male
 - Satisfied with inanimate objects (**bra and underpants**) of the opposite sex.

- **Voyeurism/ Scoptophilia/ Peeping Tom**
 - Comes under 354C IPC (**C for Seeing a girl**)
 - Watching the removal of clothes by a girl
 - Watching match girl take bath.
 - **Mixoscopia:** A type of voyeurism in which sexual gratification is obtained by the sight of others engaged in sex.

- **Fetichism**
 - Punishable under **290 IPC for 3 months**
 - Rubbing private parts against a female's buttocks or thigh

- **Masturbation/ Onanism/ Ipsation**
 - Self-stimulation of genitalia.
 - Punishable under **290 IPC, if done in public.**

- **Coprolalia:** Obscene language
- **Scatalogia:** Obscene telephone calls.
- **Partialism:** Sexual interest with specific body part other than genitalia.
- **Klismaphilia:** Sexual gratification by **enema**
- **Ecouterism:** Listening the sounds associated with sexual intercourse.
- **Nymphomania:** Excessive sexual desire **in females.**
- **Satyriasis:** Increased sexual desire **in males.**

- **Dippoldism**
 - Dippold, a German schoolmaster
 - **Teacher beating** a student for sexual satisfaction.
- **Gerontophilia:** Sex with **old**
- **Pedophilia:** Sex with **child**
- **Narratophilia:** Sexual stimulation by **reading erotic material.**
- **Somnophilia:** Sexual arousal by a stranger who is asleep.
- **Pyromania:** Sexually satisfied by **setting fire.**
- **Playing the bagpipes:** Having intercourse under the **armpits.**
- **Troillism:** Intercourse between three people

Table 6.1

Extensions	Imprisonment	Description
IPC 376 A - COMA	<ul style="list-style-type: none"> Life imprisonment Sentence to death 	Inflicts an injury that causes the death of the woman or causes the woman to be in a persistent vegetative state.
IPC 376 B - Bride during separation	<ul style="list-style-type: none"> 2 to 7 years 	Sexual intercourse with his own wife, who is living separately , whether a decree of separation or without her consent.
IPC 376 C - Authority	<ul style="list-style-type: none"> 5 to 7 years 	Authority or in a fiduciary relationship, public servant, superintendent or manager of a jail, remand home, or hospital who abuses such position and induces or seduces any woman in his custody to have sexual intercourse with him which is not amounting to the offense of rape.
IPC 376 D - Two (Do) or more	<ul style="list-style-type: none"> 20 years Life imprisonment 	Rape by one or more persons (gang rape)
IPC 376 E - Excessive severe/ Repeat offense	<ul style="list-style-type: none"> Life imprisonment Sentence to death 	Repeat offense under any of the above-said sections by the same person who has been previously convicted



PREVIOUS YEAR QUESTIONS



Q. A 14 year-old rape victim was brought to the hospital with 22 weeks pregnancy. All of the following are correct statement regarding the case. Except? (AIIMS-NOV-2017)

- A. Vaginal swab need to be taken
- B. The fetus can be aborted after her consent**
- C. Examination can be done by a male doctor with a female
- D. Urine pregnancy test is not necessary

Q. A man continues to call females. Achieves sexual gratification by talking obscenity & sharing obscene picture. The condition is? (AIIMS -AUG-2020)

- A. Scatologia**
- A. Stalking
- B. Scopophilia
- C. Voyeurism

prince kumar
princeeeekum@gmail.com
9928609733



CROSS WORD PUZZLES



Crossword Puzzle

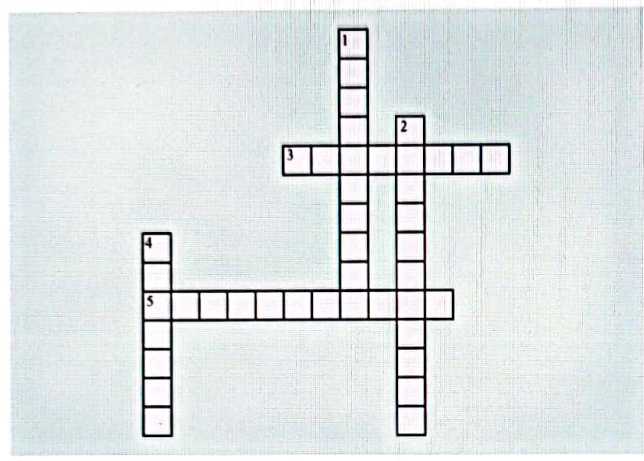

Across

- 3. Oral stimulation of male genitalia
- 5. Eating dead body parts

Down

- 1. Sadism
- 2. Sexual Perversions
- 4. sadism + masochism

prince kumar
 princeeekum@gmail.com
 9928609733

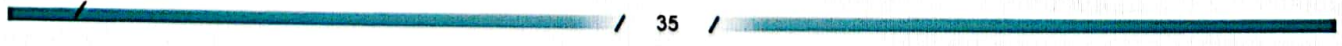

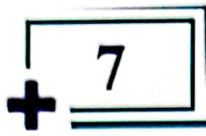

prince kumar
princeeeekum@gmail.com
9928609733

IMPOTENCE AND STERILITY



Impotence

- AKA **Erectile dysfunction**
- **Impotence for a man**- Males cannot achieve/ maintain/ initiate a penile erection.

Remember: Impotency in rape is not a defense.

Causes of Male Impotence

- **Most common cause is psychological.**
 - **Examples**
 - Anxiety
 - Depression
 - Serious stress
 - Fear
 - Tension
- **Most common organic cause**
 - **Vasculogenic**
 - Hypertension
 - Decrease in blood flow.
- **Honeymoon Impotence**
 - It is temporary.
 - Cause due to anxiety.
- **Other Causes of Impotence**
 - Neurogenic
 - Congenital causes
 - Acquired causes like hydrocele.

Impotence Quoad Hanc: If a male is impotent for a particular woman or girl

Frigidity (Female+Rigid)

00:03:46

- AKA **female impotence**
- **Definition:** Inability to initiate or maintain the sexual arousal pattern in the female

Most Common Cause

- **Vaginismus** - Fear of all types of vaginal penetration (**spasm of the vagina**)
- **Reason:** Painful involuntary contractions of pelvic floor muscles, vaginal wall muscles, or some muscles of the adductor of the thigh.

Impotence Quoad Hunc: If a female is impotent for a particular man

Sterility

00:06:10

- Not a ground for divorce
 - **Male** - If a male unable to beget children
 - **Female** - Not able to conceive.

Hindu Marriage Act

00:07:11

HMA - Hindu Marriage Act Section 5 describes the validity of the marriage.

Marriage,

- **Nullity of marriage (HMA- 11 and 12)**
 - Null and Void Marriage (**Not valid in law**)
 - Process - Annulment
 - **Void** - Married at the beginning.
 - **Voidable**-The party goes to the court and pieces of evidence are produced.
- **Divorce (HMA-13)**
 - Legal separation in a legal marriage.

Nullity of Marriage

Void	Voidable
<ul style="list-style-type: none"> • Beginning - Zero • Already Married - BIGAMY • Prohibited relationship. <ul style="list-style-type: none"> ○ Between father and daughter ○ Between mother and son 	<ul style="list-style-type: none"> • Parties go to the court and multiple evidences are produced then it becomes zero (Court gives the decision) • Impotence at the time of the marriage • Impersonation - Marrying a different person. • Impregnation - Already pregnant and marrying someone else. • Invalid consent <ul style="list-style-type: none"> ○ Age - Underage ○ Fraud - Fraud details ○ Intoxication - Under consent of alcohol etc... • Insane-Insane before the marriage

Ground for Divorce

- Impotence after marriage
- Frigidity

To Remember

- Best ground for divorce is **Impotence after marriage.**
- Impotence after marriage > Frigidity

Grounds of Divorce

- **D: Desertion** - Abandoned for **2 or more** years
- **I: Insane** - If Incurable
- **V: Venereal Disease** - If any kind of dangerous disease like **HIV**

prince kumar
princeekum@gmail.com
937609733

- **O: Offense - Rape and bestiality**
- **R: Renunciation**-If the partner becomes a saint or a religious person
- **C: Cruelty** - Physical and mental cruelty
- **E: Extramarital Affair** - Adultery

Fecundation ab Extra- Rare Condition

- A very rare condition.
- Semen is deposited at an extra site but still females get conceived without penetration.
- Conception occurs in a woman when semen was deposited on her thighs or on the vulva.
- This can be considered as a ground for the nullity of marriage.

Legitimacy (112 - IEC)

00:17:53

- If a child is born in a valid lawful marriage.
- Or if a child born in **280 days after dissolution** (a kind of separation due to death or divorce) remains unmarried, The child is legitimate.

Posthumous Child

- Child born after the death of parents (father).
- Case of disputed paternity is known as an **Affiliation case**.

Supposititious/ Fictitious/ Substituted Child

- Intention - Blackmailing to obtain money or property.
- Methods - Claims the child as her own child.
 - Feign pregnancy.
 - Dead fetus
 - Kidnapping the child

Twin Pregnancy

Superfecundation	Superfetation		
1T	2T		
1 MC cycle	2 MC cycle		
2 ova fertilized	2 ova fertilized (a very rare case)		
2 different acts of coitus	2 different acts of coitus		
Same man or different	Same man or different		
	Same	Different	Same Different
Mono-paternal	Bi-paternal	Mono-paternal	Bi-paternal
Growth	Growth		
	Equal development of fetus	Fetus compresses/papyraceus	Higher or Lower

Pseudocyesis/ False (Spurious or Phantom Pregnancy)

- Subjective symptoms exist but are not pregnant, due to psychological(childless) or hormonal disorders.
- USG test can be done to check.
- Female needs psychological support.
- **At later stages females can feel labor pain.**

ART (Assisted Reproduction Technique)

- Artificial insemination (placing sperm in the vagina artificially)
- Surrogacy
- In Vitro fertilization (Test tube baby)
- Other (GIFT, ZIFT, etc.)
- ICSI (Intracytoplasmic Sperm Injection) - When the sperm count is very less.

Artificial Insemination Indications

00:32:14

- **Husband**
 - Impotent
 - Sterile
 - Suffering from hereditary disease
 - RH incompatibility
 - Unable to deposit semen due to hypospadias and epispadias
 - Oligospermia (Less sperm count)
 - **Azoospermia (Absence of sperm)**
- **Wife**
 - Cervical stenosis
 - Cervicitis
 - Vaginismus

ART Types

- **AIH - Artificial Insemination Husband** (semen of husband is used)
 - Consent- Husband+Wife
- **AID - Artificial Insemination Donor** (Semen of some other person)
 - Consent- Donor couple + Recipient couple
- **AIHD - Artificial Insemination Husband Donor**
 - Pooled semen

Precautions

- Consent of the donor and his wife is important.
- No risk of genetic disease and be <40 years
- RH compatibility
- Donors must be mentally and physically healthy.
- Donor must not be a relative of either spouse.
- Donors' race and characteristics should resemble the husband and have the same blood group as the husband.
- Physician should be different from the one who administers artificial insemination.
- Single donor can produce only 10 children.

Legal Problems

- Everything should be confidential.
- **Legitimacy**
 - AIH - Legitimate
 - AID - Illegitimate (should adopt after birth)
 - For single women it is definitely a legitimate child.
- Not be held guilty of adultery.
- Nullity of marriage and divorce - If Artificial Insemination is done without the consent of the husband, then one can file a case of divorce.
- Impotence is a ground of Nullity.
- Artificial Insemination due to sterility is not a ground for divorce.

Surrogacy

- Surrogate mother is a mother who carries a child for another couple.
- There are 2 types.
 - **Altruistic surrogacy** - Medical expenses are paid. 36-month health insurance is also given by the couple to the mother
 - **Commercial surrogacy** - A handsome sum is paid for the mother which is currently banned.

Surrogacy Regulation Act

- Surrogate mother should be between 25-35 years of age, should be married, should have 1 born child, or close relative, and should be certified that she is mentally and physically healthy. 3 attempts can be done.
- Intending couple - The male should be 26- 55 years old and the female should be 23-50 years old.
- 5 years marriage infertility, Indian, no child selection certificate.
- After surrogacy, the child is legitimate.
- If you go for commercial surrogacy 10-year imprisonment or 10 lakhs fine, if violate law 5-year imprisonment and 10 lakhs fine
- If a mistake is made by a doctor, registration will be canceled for 5 years.



CROSS WORD PUZZLES



Crossword Puzzle

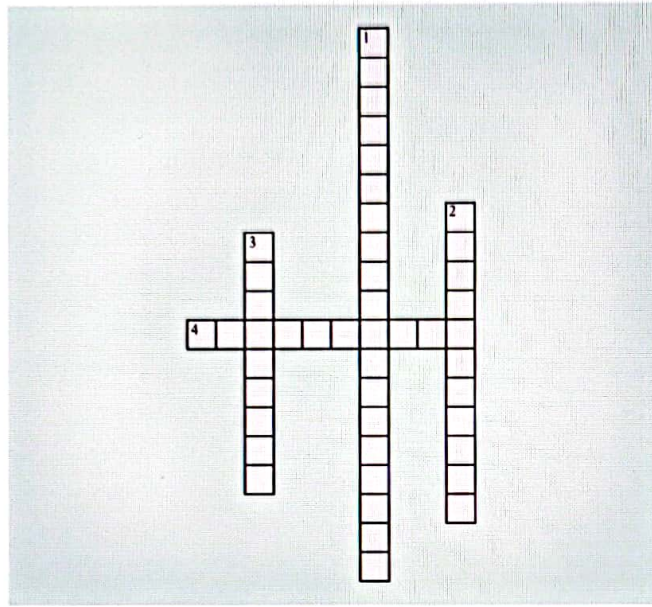

Across

- 4. Fear for all types of vaginal penetration

Down

- 1. Medical expenses are paid.
- 2. Absence of sperm
- 3. female impotence



8

VIRGINITY, ABORTION AND MTP

00:10:02

Impotence, abortion and MTP

- **Virginity:**The female who has not experienced sexual intercourse is known as virgin female.
- **Defloration:** Loss of virginity
- **Hymen:** It is a fold of mucous membrane, situation: at the vaginal Outlet

Hymen does not decide on virginity.

- **True virgin:** The female who has not experienced sexual intercourse and the hymen may or may not be intact.
- **False virgin:** The female who has experienced sexual intercourse, but the hymen is still intact. It is because the hymen may be thick, elastic, and fleshy.

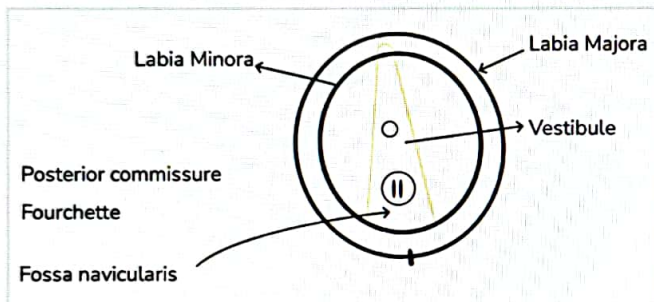

- Labia majora posteriorly fuses and forms posterior commissure.
- Labia Minora posteriorly fuses and forms a fourchette.
- Labia Minora inside fuses anteriorly and forms Clitoris.
- Fossa Navicularis is a place between fourchette and vaginal introitus.

Differences Between Sign of Virginity and Defloration

00:06:15

Virginity	Defloration
Hymen intact	Hymen torn (P-L) Post lateral
Labia Majora is closely apposition	Labia Majora is not so apposed (exposed)
Labia minora is pink	Labia minora is pigmented
Posterior commissure intact	Torn
Fourchette intact	Torn
Intact fossa Navicularis	Fossa Navicularis disappears
Narrow vaginal canal with rugosity	Dilated vaginal canal
Breasts are smaller and firm, with small pink areola, nipple	Breasts are large and flabby, areola large

Hymen

- It is a fold of mucous membrane.
- Its thickness is 1mm.
- **Types of the hymen: IS VICS**
 - Imperforate
 - S- Semilunar or crescentic
 - V- Vertical
 - Infantile
 - C- Cribriform
 - S- Septate

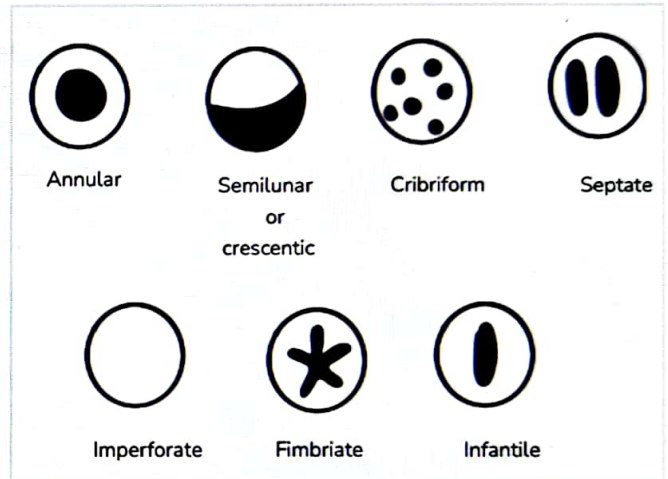

Hymen rupture causes

- Sex
- Masturbation
- Surgery
- Trauma
- Foreign body invasion (Sola-Pith)
- Hymen rupture site- Sex (penile penetration): Post lateral
- Masturbation-(finger/ foreign body): anterior or anterior lateral

Hymen rupture

- **Aptae Viris:** Rendering very young girls fit for sexual intercourse (Sola pith invaded in the vagina, it absorbs moisture and gets dilated, the vagina also gets dilated and becomes fit for sexual intercourse) (commercial sex workers)
- **Sexual Assault Of Female Child:** Hymen does not rupture in this because in a female child it is deep-seated.
- **True Virgin:** No sexual intercourse, the hymen may or may not be intact.
- **False Virgin:** Sex intercourse, the hymen is still intact, shows deflorated symptoms.

Differences between Hymenal tear and Fimbriated hymen

	Hymenal Tear	Fimbriated Hymen
	It can be on any side	It is on the anterior side
Situation of notches	Extend to the vaginal wall or periphery	Don't extend to the vaginal wall or periphery
Shape and size	Asymmetrical	Bi-lateral and symmetrical,
Mucous membrane over notches	Absent	Intact
Cause	Sex, masturbation	Natural

Glaister keen rod (examine margin of the hymen)

It is like a glass rod with a bulb at one of its ends. This rod is placed in the vagina and then gently pulled out. The bulb is illuminated to examine the margin of the hymen.

- Carunculae hymenales Myrtiliformes: These are small, round, fleshy projections found in already destroyed hymen in women
 - o Who is used to having coitus
 - o After childbirth.

Pregnancy sign-Presumptive signs

00:23:45

- Amenorrhea is the earliest sign of Pregnancy.
- Quickening: fluttering movements in her abdomen, seen at about 16th to 20th week.
- Chadwick's or Jacquemier's sign: Seen at about 4th week. The Mucosa of the vagina changes from pink to blue due to venous obstruction.
- Morning sickness, Montgomery tubercles in the breast, urinary disturbances, etc.

Pregnancy sign- Probable signs

- Hegar sign: The isthmus, between the hard cervix and elastic uterus, is compressible and soft. Seen at about 6th week. This is the most valuable physical sign of early pregnancy.
- Goodell's sign: Softening of the cervix. Well-marked at about 4th month.
- Braxton-Hicks sign: intermittent painless uterine contraction. Easily felt after 4 months - Ballotment (4th and 5th month) and enlargement of the abdomen.

Pregnancy sign-Positive signs

- Fetal movements after the 16th week and fetal parts can be distinctly felt after 24 weeks of gestation.
- Fetal heart sounds are heard between 18 to 20 weeks.
- Fetal parts can be detected in X-ray at about the 15th to 16th week.

- USG: Gestational sac (6th week), distinct echo from embryo (7th week), heartbeat (10th week). Along with placental soufflé and umbilical soufflé are important signs.

Lochia (discharge from the vagina after delivery)

- Rubra: 1 to 3-4 days (Dark red)
- Serosa: 4-10 days (Pinkish brown)
- Alba: 10-28 days (White yellow)

Abortion -premature expulsion of the fetus

- Product of conception
- Viability of fetus: Capable of survival outside 28 weeks.
- Full Term- 280 DAYS (40 weeks)
- Medical abortion-expulsion before age of viability (28 weeks)
- Legal definition of abortion-expulsion before full-term (any time)

Types Of Abortion

1. Natural:

- Spontaneous: first trimester, chromosome abnormalities, anatomical infection, etc.

2. Induced

- MTP (legal): It is lawful, MTP (medical termination of pregnancy) indications are there, and doctors are also present.
- Criminal: It is unlawful, MTP indications and doctors are not there.

MTP Act (Medical Termination of Pregnancy)

00:34:13

- It was implemented in 1971.
- It came to action in 1972.
- It got amended in 2021.
- Consent is taken from Mother (female) (age more than or equal to 18 years) Confidentiality (punishment): 1 year or fine or both.

Indications:

- Contraceptive failure (social)
- Child malformed (Eugenic)
- Risk of life of the mother, physical or mental Anomaly (Therapeutic)
- Rape (Humanitarian)

Firstly, abortion is to be done up to 20 weeks now it is done up to 24 weeks.

- If it is done for up to 20 weeks, then 1 doctor will be there.
- If it is done up to 20 to 24 weeks, then 2 doctors will be there.

MTP is done.

1. Up to 20 weeks because of contraceptive failure
2. After 24 weeks because of substantial fetal abnormalities. Medical Board for this consists of

- OBG
 - Pediatrician
 - Radiologist/Sonologist
 - Any other member (gazetted officer)
3. Any time to save life of pregnant female (1 doctor can do this)
MTP is done in government institutions and institutions approved by the government.
- RMP -> 25 Assisted = MTP
 - 6 months house job in OBG
 - OBG degree: MD/MS/Diploma/DNB
 - 1 year experience in OBG department.

Legal Aspects- Criminal abortion

- S.312, IPC: woman, consent should be there.
- S.313, IPC: Without consent. S.314, IPC: Death of the women.
- S.315, IPC: With intent to prevent a child from being born alive/ to cause it to die after birth. Here pregnancy is typically >28 weeks.
- S.316, IPC: Aim was to kill the mother, but the death of her quick unborn child is caused. This is culpable homicide not amounting to murder.

Criminal abortion methods

- Up to the end of the first month: violent exercise
- Up to the end of the second month: abortifacient drugs
- 3rd or 4th month: mechanical interference

Abortifacient drugs

Ecbolics (cause uterine contraction)

- Ergot
- Quinine
- Strychnine
- Oestrogen

Emmenagogues (increase menstrual flow)

- Borax
- Estrogen

- Sanguinarine
- Savin
- Senecio
- Irritation of GUT
- Cantharides, oil of turpentine, castor oil, and magnesium sulfate as purgatives.

Violence Methods

LOCAL- Higginson's syringing (AIR / Soap water in the uterus), rupturing the membrane (pointed object), abortion sticks, dilation of the cervix (slippery elm bark and drugs), Dilatation and Curettage, air insufflation.

The abortion stick is 12 to 18 cm long and soaked with the juice of calotropis and castor.

- Plumbago
- Ergot
- Calotropis
- Oleander (white: Nerium odorum and yellow: cerebra thevetia)
- Lead, copper, mercury
- utus paste - paste of iodine and KI
- Aconita, Abus, Arsense

General violence

- Trauma and violent exercises.
- Cupping-lighted wick covered with cup or mug.

Causes of death

- Hemorrhage
- Vagal inhibition
- Air embolism
- Fat embolism,
- Amniotic fluid embolism
- Septicemia



CROSS WORD PUZZLES



Crossword Puzzle

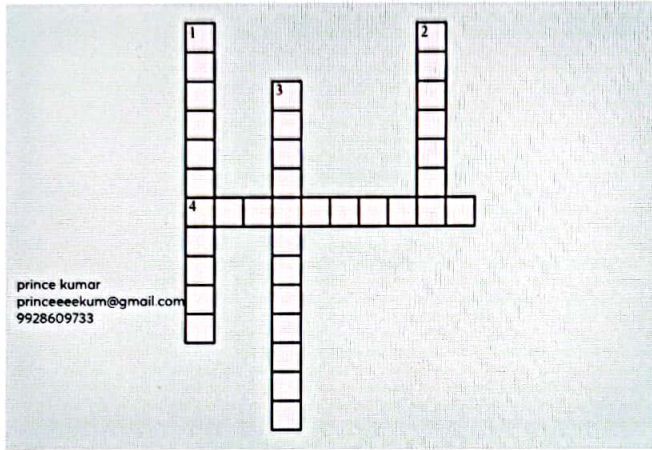

Across

- 4. earliest sign of pregnancy

Down

- 1. Loss of virginity
- 2. Abortifacient drugs
- 3. increase menstrual flow

9

MEDICAL JURISPRUDENCE

Medical Jurisprudence

- It is the application of the law for medicine.
- Forensic medicine: Application of medicine for law
- It deals with the legal responsibility of a doctor arising during the practice of medicine such as Consent, Negligence, wrong practice, and malpractice.

Indian Medical Council act (1956)

00:01:25

- The Medical Council of India has been converted into NMC (National Medical Commission).
- First schedule: Recognized medical qualifications granted in medical universities of India.
- Second schedule: Granted outside India or Foreign Medical (FMG).
- Third Schedule:
 - Part I of the third schedule: The medical schedules inside India don't come under schedule 1.
 - Part II of the third schedule: The FMG which doesn't come under Schedule 2.

Medical Etiquette

- It is the conventional law of courtesy observed between members of medical professions.

Medical Ethics

- It is a set of moral principles which guide members of the medical profession while dealing with:
 - Doctor with Doctor
 - Doctor with patient
 - Doctor with state or society

Serious Professional Misconduct / Infamous Conduct

- Any conduct which might be regarded as disgraceful/dishonorable during practice.
- Warning notice is given for infamous conduct during practice.
- It is not a complete list. Warning notice for:
 - Alcoholism
 - Addiction (Drug addiction)
 - Advertisement (wrong or many advertisements)
 - Association with an unqualified person
 - Adultery (Extramarital affair)
 - Abortion (criminal abortion)
 - Bribe
 - Covering (assisting any unqualified person or taking assistance from an unqualified person)
 - Dichotomy (Fee Splitting: Either giving or taking commission)
 - Euthanasia (Painless killing)
 - False certificate (IPC section 197)
 - Gift (taking gift)

Disciplinary Control by:

- SMC (State Medical Council). This council makes a committee of doctors. This committee decided whether the act is ethical or unethical. If the act is unethical:
 - Warning: Not to repeat the offense.
 - Suspension: Can give the temporary suspension
 - Penal Erasure / Professional death sentence: Erasure of the name of a doctor from the medical register.
 - Appeal: If one gets Penal Erasure, they can appeal at the Central Health Ministry. If CHM also agrees then it can be confirmed again by MCI.

Euthanasia or Mercy Killing (Painless Death)

00:15:00

- For the disease which is terminal or incurable.
- Article of Indian constitution 21: Right to Live. Euthanasia breaches this article.
- Types:
 - Active:
 - You are giving drugs such as Phenobarbital, Thiopentone sodium, Insulin, Potassium
 - Passive (legalized in India): Removal of the lifeline procedure such as ICU.
 - Netherlands was the first country where Passive euthanasia was legalized. Other countries included Belgium, Sweden, and Thailand.
- Types on basis of the will of the patient:
 - Voluntary: Patient willing to die.
 - Non-Voluntary: Patient not able to give will. Ex: Patient in Coma.
 - Involuntary: Without the will of the patient.

Living Will:

- Document: Made for a treatment option. Ex: during Coma, Terminal, ICU; you are giving a document, what would happen.
- Living will be written by any person whose age is ≥ 18 years with a sound mind.
- It is signed by 2 witnesses.
- Nominated Representative: In this NR, could be a doctor, or relative.
- It is attested by 1st class J.M
- If two living wills are made, the last one will be valid.
- Multiple steps are taken after this, whether eligible for euthanasia or not.
- Steps:
 - Treating Doctor: First the Treating doctor will decide, the patient is eligible for painless death or not.
 - Medical Board: Then, a medical board is made with at least 3 doctors.
 - Collector: Then they sent the requisition to the Collector.
 - Then they send the requisition to 1st class J.M.

Doctor can Advertise.

- Practice:
 - Doctors starting the practice can advertise.
 - If you temporarily stop (cessation) of the practice.
- Health Awareness:
 - Any public health awareness can be advertised.
- Change:
 - Change in address and change in the type of practice can be advertised otherwise it is illegal.

Professional Secrecy

00:25:01

- Doctor is obliged to maintain the secret/disease of the patient.
- If a doctor is disclosing the patient's information to anyone, it is a Punishable offense.

Privileged Communication

- Exception of Professional Secrecy.
- Doctor is obliged to communicate about the patient to some concerned authority.
- **Cases of Privileged Communication:**
 - Crime (suspected case): According to 39 CrPC, a doctor should inform the police or magistrate.
 - Infectious disease: For this, communication with relative or family members
 - Venereal Disease: Like for HIV, Hepatitis, communicate to partner or spouse.
 - Interest (self) if a doctor performs surgery and is published in a newspaper with your name. But consent of the patient is taken.
 - Court of Law: If the court asks anything from a doctor like in a medical negligence case.
 - Servant / Employer: Any disease, life endangering for others, should be informed to the employee. Example: You are a train driver and have color Blindness.
 - Interest of Patient: Psychotic patient having suicidal tendencies, it should be informed to relative or Guardian.
 - Negligence suit / Notifiable disease: If a doctor performs some mistake, they should inform the patient / relative. Notifiable diseases like Cholera, Corona, you must inform the health department as these are risks for society.

Consent

00:32:45

- Taken by a doctor and given by the patient. It is present in the Indian contract act given in clause 13.
- Medical Examination:

In this case, you should take consent otherwise it will come under assault and will be punishable under 351 IPC.
- Any procedure:

Like Blood Transfusion, you should take consent.
- Victim Examination:

Consent is a must.
53 CrPC

- Accused Examination:

Consent is not required.
- Prisoner:

In an examination of prisoners, consent is not required.
- An arrested person:

Can give requisition for medical examination. (54 CrPC)
- Mass Immunization:

Consent is not required.
- Contraceptive, sterilization, and artificial insemination:

Consent is required from both partners.
- **Types:**
 - Express Consent: If you say (verbal) if you write (written)
 - Implied Consent: No verbal or written but by gesture or by the act, you are ready. Example: If Dr. checks blood pressure, you give your hand (this means you are giving consent).
 - Informed Consent: if Dr. informs ~~everything to patients~~ ^{prince kumar 9928609733}. The best-informed consent is written consent.
 - Blanket Consent: Open / Blind consent. Here in single consent, you are considering multiple procedures. Example: Once you are admitted in hospital, all procedure consent is taken at one time.

→ It is not valid in India.
 - Substituted Consent: Not able to give consent. Relatives, guardians, friends will give their consent.

Full Disclosure VS Therapeutic Privilege

- Doctor discloses everything to patients like Diagnosis, Treatment, complications, and follow-up.
- After disclosure, the patient has the right to refuse known as the doctrine of informed refusal.
- Exception of full disclosure is Therapeutic Privilege. Like when the patient is psychotic and has a suicidal tendency. For benefit, this should be informed to relatives or the Guardian.

Exceptions of Informed Consent

- Emergency
- Therapeutic Privilege
- When a patient waives his right of informed consent to doctor or relatives.
- Mass Immunization
- Medicolegal autopsy
- Convicted Prisoner and examination of accused.
- Doctrine of extended consent: Some unanticipated situations that doctors should treat.

Consent Laws

- If your age is ≥ 18 , & you are going for paragliding or surgery, you are not intended or likely to cause death, you can give consent. This is an 87 IPC.
- 88 IPC- Act not intended to cause death, done by consent in good faith for a person's benefit.

- o AGE- no age limit
- o Dr performs surgery for x and knows there is no cause for death.
- 89 IPC
 - o Act Done in Good Faith for Benefit of Child or Insane Person, By Consent of Guardian (lawful charge)
- 90 IPC-
 - o Consent not Valid- child < 12y, insane, intoxicated, under influence of threat or fear.
- 92 IPC-
 - o Life-threatening/ Emergency Situations- No consent. Ex- Road accident
- **Consent age limit for:**
 - o Physical Examination: >= 12 yrs
 - o Surgery >= 18 yrs

Medical Negligence / Malpraxis 00:47:05

- It is absence of skill or absence of care. Sometimes it is very gross negligence or willful negligence.
- It is by either doctor or by any medical staff.
- **For proving negligence:**
 - o Duty: The doctor should be on duty
 - o Dereliction: Absence of care / wrong duty. For example- the doctor was present but prescribed the wrong drugs.
 - o Direct Causation: because of prescription
 - o Damage- directly cause damage (side-effect, problem to you)

Civil VS Criminal

	Civil	Criminal
Negligence	Absence of care/skill	Gross negligence/ willful negligence
The burden of proof / Ovius	Patients need to prove	Doctors need to prove
Punishment	Punishment is given on a monetary basis	304A IPC punishment
Trail By	By Civil/consumer court	By criminal court

- Example- Wrong antibiotics, and drug overdose, these are leading side effects and are civil negligence.
- Example- During surgery, you left a swab in the body.
- There was right leg gangrene, but you amputated the left leg after drinking alcohol, then this is criminal negligence.

Medical negligence IPC

- 304A IPC- Accident, punishment is 2year ± fine.
- IPC 336- danger in life due to negligence.
- IPC 337- hurt due to negligence.
- IPC 338- Grievous hurt due to negligence.

Contributory Negligence 00:53:47

- Negligence by doctor and patient.
- Ex- the patient is not taking treatment properly, patients are not coming for follow-up, the patient has not given proper history.
- It is a defense in a civil case.
- Doctor needs to prove that the patient has contributed.
- It is a partial defense.

Limitations to contributory Negligence

1. Last clear chance Doctrine:

- Doctor is responsible because the doctor was having the last chance that the doctor missed.
- Example: Doctor asked patient to come for frequent dressing after surgery. Patient came after 7 days, now the doctor must inform them that it can cause infection if the patient does not come for a dressing. If the doctor doesn't inform, the doctor is responsible.
- Another example can be a snake bite in which there is tight ligature. If the doctor doesn't remove it, it is the doctor's responsibility.

2. The avoidable consequences rule:

- Here the patient is responsible.
- Example- the doctor tells the patient to come for dressing but even after informing patient doesn't follow the information and gets infected.
- If the negligence of a patient aggravated the damage already caused by the negligence of the doctor.
- Example- The doctor went for surgery but didn't prescribe antibiotics or wound dressing. This is negligence caused by the doctor. Now after this, the patient applies cow dung on the wound, this is an avoidable consequence as the patient should not do this, but the doctor cannot plead for contributory Negligence.

Defenses against Negligence 01:00:00

1. **No duty:** If Dr. Proved doctor was not on duty.
2. **Duty discharge:** if the duty of Dr is discharged.
3. **Therapeutic misadventure:** During treatment, any unintentional accidental complication.
 - o Ex: if you are going for surgery, and your GI tract is perforated unintentionally. Dr needs to prove it. If proven, it can be a defense in civil & Criminal negligence.
4. **Error of judgment:** It is an important defense.
5. **Contributory Negligence:** It is negligence by doctor and patient and is a defense in civil cases.
6. **Res Judicata:** It is related to the court. If the question of negligence is decided, it cannot be raised again. You can appeal but not in the same hearing or court.
7. **Res indicata:** Time Limitation. If a patient wants to file a case against a doctor, it should be filed within two years.

The doctrine of Res IPSA LOQUITUR

- Things/facts which speak for itself.
 - Ex- You left a swab in the body during surgery. This swab is a fact in the body. There was an act of omission and there was a lack of standard of care & treatment.
- It proves 100% negligence.
- It proves both civil as well as criminal negligence.
- Criteria:
 - In absence of negligence, injury or damage wouldn't have occurred.
 - The Doctor has exclusive control over injury and negligence.
 - There was no contributory Negligence.

Doctrine of Common knowledge

- Every doctor should have common knowledge.
 - If you have an injury, you should give TT; If you have dehydration, you should give IV fluid or other which is required.
 - But if whatever is required and you are not giving, it is an act of omission.
- It is a variant of Res Ipsa Loquitur.
- It is an act of omission.

Calculated risk Doctrine

- Defense in a civil case
- Every method of treatment you employed had unavoidable risk and you have taken reasonable care. If the risk happens, it is known as the Calculated Risk Doctrine.

Novus Actus Interveniens

- New action intervening
- Breaks the chain of events and consequences.
- Ex: Y stabbed X, but the stabbed person was admitted to the hospital. Now due to the doctor, there is a fluid problem, electrolytic problem, and septicemia and the patient dies. This blood transfusion problem is created by doctors and patients die due to that. Here, the doctor is also responsible.

Vicarious Liability

- There are two people: Employer & Employee.
 - The employer is responsible for his negligence as well as the negligence of the employee.
- Ex: You are HOD & surgeon of the department and under power, you are doing surgery and some other doctor causes negligence. The surgeon is also responsible.
- It is **Let Master Answer or Respondent Superior**.
- Ex: A Doctor is working under Fortis hospital and if he gets negligence, the first responsibility to clear anything is Fortis hospital because the owner is superior/ Respondent.

- There must be Employer - Employee relationship.
- It should be done within the **scope of the employer**.
- It should be done while on the job.

Medical Mal-Occurrence

- In some cases, in spite of good medical attention and care, there is an **adverse drug reaction or wrong response by the patient, the doctor can defend**. This is known as Medical Mal-Occurrence.

Composite negligence

- Patient suffers injury from a negligent act by more than one person.

Product Liability

- It refers to the **physical agent which causes damage**. Ex: instrument
- **The burden of proof is on the manufacturer.**

Borrowed servant doctrine.

- If you are a surgeon but you borrowed a temporary staff from any other department and because of this there is negligence, you will be responsible because you borrowed the wrong servant. This is known as the Borrowed Servant doctrine.

Loco Parents

- Sometimes in place of parents, **consent can be given by warden, police, or other guardians.**

Maintenance of Medical Records

- Indoor parents- for 3 years
- Routine cases- 6 years after completion of treatment
- After death- at least 3 years
- Medico Legal document- 10 years
- Copy of any of these documents must be given within 72 hours.

Medical Negligence Act

1. Bolam test:

- It states that if a doctor has acted according to proper and accepted practice.
- Standard of care should be judged by one's own peers & not by senior consultants.

2. Bolitho Test (Modified Bolam Test):

- **Legal assessment of medical negligence.**
- The defense and its body of opinion must be reasonable and responsible as well as logical.

Geneva	Hippocratic oath (genuine path)
Tokyo	Torture (physician duty during torture), Istanbul protocol
Sydney	Definition of death
Oslo	Therapeutic Abortion
Helsinki	Human experimentation
Venice	Terminal illness
Lisbon	Rights of patients
Malta	Hunger strike
Washington	Biological warfare
Ottawa	Child Health
Hong Kong	Old abuse

prince kumar
princeeeekum@gmail.com
9928609733



PREVIOUS YEAR QUESTIONS



Q. A 14-year-old girl was kidnapped by a male. While the police arrested him, he died in police custody. The inquest is conducted by? (FMGE-Aug-2020)

- A. **Judicial magistrate**
- B. Medical examiner
- C. Police
- D. Coroner

Q. The time limit for ordering an exhumation in India is? FMGE - MAY - 2018

- A. 1 years
- B. 10 years
- C. 20 years
- D. **No limit**

Q. In case of death in lock up. The inquest is held by? (FMGE MAY - 2018)

- A. A Police officer
- B. **Magistrate**
- C. Panchayat officer
- D. District attorney

Q. Firsthand knowledge refer to? (AIIMS-MAY-2018)

- A. Opinion of a doctor in court
- B. Handwriting expert
- C. **Common witness**
- D. Fingerprint expert

Q. When the victim is dying because of unlawful act, the police recorded dying declaration. The doctor certified that the victim was conscious and mentally oriented. Under what circumstances, the dying declaration is invalid? (FMGE - Aug - 2020)

- A. If the victim is not dead
- B. Victim didn't sign the declaration
- C. **Declarant is not expecting death**
- D. It is done by the doctor

Q. While doing hysterectomy after informed consent for uterine fibroids. Ureter is damaged intraoperatively even after diligent measures. A doctor is not responsible under which doctrine? (FMGE Dec 2020)

- A. **Medical maloccurrence**
- B. Novus act us interveniens
- C. Physician error
- D. Res ipsa loquitur

Q. A doctor takes consent, before surgical procedures and also, he may go beyond the consent if he feels the need for patients benefit? (AIIMS Jun 2020)

- A. **Doctrine of extended consent**
- B. Doctrine OF conjugated consent
- C. Res ipsa loquitur
- D. Doctrine of anticipation



CROSS WORD PUZZLES



Crossword Puzzle

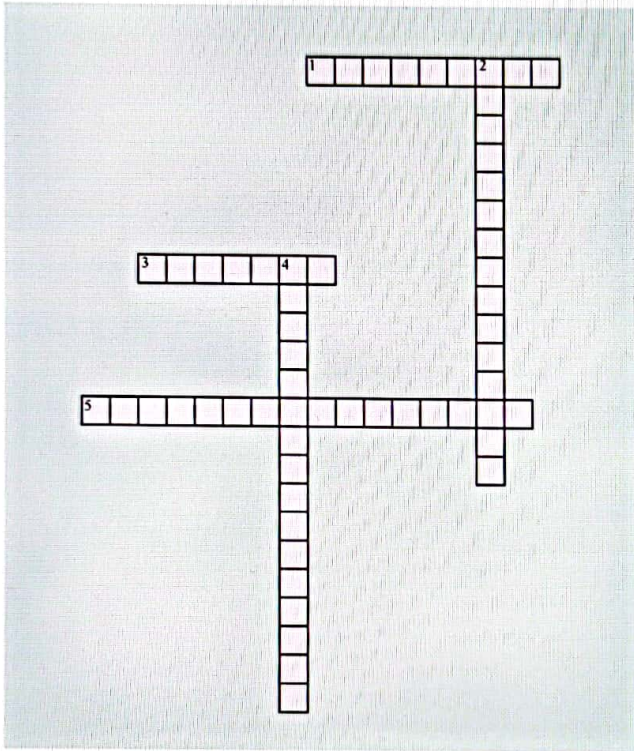

Across

- 1. if a doctor has acted according to proper and accepted practice.
- 3. Accident, punishment is 2yr +- five
- 5. Application of medicine for law

Down

- 2. If you say (verbal) if you write (written)
- 4. physical agent which causes damage



10 INFANTICIDE

prince.kumar
princekumar1@gmail.com
9928609733

Fetal/Newborn/Infant Autopsy

- When conducting fetal/newborn/infant autopsy
 - First cavity to be opened - **Abdominal cavity.**
 - To see the **position of the diaphragm**
- method employed.
 - **ROKITANSKY**
 - in-situ method
 - No organ is taken out.
 - Other methods can also be used.
 - Virchow's
 - Ghon's
 - Letulle's
- Cranial cavity opening in the fetus
 - **BENEKE'S method**
 - Cranial cavity divided into two parts.
 - **BARR'S method**
 - Cranial cavity divided into four parts.

Tip To Remember

- **BaBy** - Beneke's and Barr's

Infanticide

00:02:38

- Killing a child under the age of 1 year
- Neonatal period up to 28 days
- **Neonaticide** - Killing a child **within 24 hours of birth.**
- **Feticide** - Killing a fetus
- **Filicide** - Killing a child by its own parents.

IPC

- No separate IPC for infanticide
- Punished under 302 IPC - Same for murder.

S.315 IPC

- Related to causing death.
- **With intent to prevent the child from being born alive or to cause it to die just after birth**
- Usually, gestational age >28 weeks

S.316 IPC

- **Aim was to kill the mother, but the death of her quick the unborn child is caused.**
- Amount to **culpable homicide**

Viability of fetus

- Age of fetus after which fetus is capable of survival outside.
- Before age of viability - it is called abortion

- 28 weeks of gestation
- 210 days
- Length - 35 cm
- Weight - 900g - 1200g
- Fingernails - thick
- Meconium - in the large intestine
- Eyelids - open and pupillary membrane - disappeared.
- Testes are found at the external inguinal ring.
- Ossification Centers Appear in
 - 2nd and 3rd piece of the sternum.
 - Talus

Tip To Remember

- **Viability - SevenTh month**
 - S- sternum 2nd and 3rd piece
 - T- talus

After 28 weeks

- **Viable**
- **Dead born**
 - Fetus died inside the uterus
 - **IUD** - intrauterine death
- **Stillbirth**
 - Fetus died during the process of delivery.
 - **In birth passages**
- **Live birth**
 - Foetus came out.
 - Expulsion of the fetus and **shown signs of life**

Dead Born

00:12:26

Signs

- **SHORMA**
- **S - SPALDING SIGN**
- **H - Hyperflexion of Spine - DEUEL'S HALO SIGN**
- **O - Overcrowding of ribs**
- **R - Rigour Mortis**
 - Stiffening of muscles
- **R - ROBERT SIGN**
- **M - Mummification**
- **A - Aseptic autolysis**
 - Also called Maceration.

Maceration

- **Most important sign**
- Also called aseptic autolysis
 - No bacteria involved.
 - Self-lysis

- **Conditions required.**
 - Intact Amniotic Sac.
 - With plenty of amniotic fluid.

Changes in maceration

- **SSSSSA**
- **Skin slippage/Reddening of skin/Peeling of skin**
 - When pressure is applied to the skin - The skin will peel off
 - After **12 hours**
 - **Earliest sign of maceration**
- **Skin blister/Blebs**
 - **24 hours**
- **Softening of joints**
 - **Flaccid body**
 - 48 hours /2 days
 - **Hypermobility joint**
- **Sweatish/disagreeable odour**
- **Subcutaneous edema**
 - 5th day
 - Thickness >5mm
- **Abdominal distension**



Maceration showing

- Skin slippage/Skin peeled off.
- Reddening of the skin.

Maceration - stages

- **Mild** - only skin slippage
- **Moderate** - skin slippage + softening of organs
- **Severe** - skin slippage + softening of organs + hypermobile joints

Mummification

- **Conditions required.**
 - Intact amniotic sac
 - With a deficient blood supply of the fetus.
 - Scanty amount of amniotic fluid.
 - No air
 - Dehydrated fetus.



Putrefaction

- Kind of decomposition
- **Amniotic sac not intact**
- Ruptured amniotic sac.
- Bacterial entry

Radiological signs of Dead born

- **ROBERT'S Sign**
 - Gas
 - In aorta
 - In the pulmonary artery.
 - In the cardiac chamber.
 - In the umbilical artery.
 - 12 hours after death
 - **Earliest radiological sign**
- **SPALDING SIGN**
 - 4-7 days after death
 - **Overriding of cranial bones.**
 - Loss of alignment of cranial bones.
 - Because of **liquefaction of the brain.**
 - Support of cranial bones is lost.
 - **More common in vertex presentation.**
 - Pathognomonic sign.
- **Hyperflexion of Spine**
 - Hypermobility joint
 - **Ball sign**
 - Vertebral column collapses
- **Overcrowding of ribs**
 - Softening of organ

- **Halo sign - DEUEL'S HALO SIGN**
 - Halo in fetal head
 - Separation of subcutaneous fat from the skull.

Live birth

00:30:19

- Any sign of life after the complete birth of a child.
- Or complete expulsion of product of conception.

Signs

- Breathing
- Cry of baby
- Movements of baby
- Pulsations
- Cardiac activity

Given in the Registration Of Birth And Death Act 1969

	No respiration	Respiration
Level of diaphragm	4-5 ribs	6-7 ribs
Chest	Flat	Expanded
Lung - Volume	Less	More
Size	Small	Bigger
Margin	Sharp	Round
Consistency	Solid, Firm, Dense	Spongy, Crepitant
Weight	30g = 1/70 of body weight	60g = 1/35 of body weight
Colour	Bluish violet Uniform	Light red Mottled areas
Epithelium	Cuboidal	Squamous
Specific gravity	1.04	0.94

Live birth tests

1. **Wreden's test**
 - Air in the middle ear
 - wrEdEn's - EE - air in the ear
 - No respiration - middle ear shows gelatinous tissue.
2. **Fodere's test/static**
 - Lung weight becomes two-fold.
 - Fodere - two-fold
3. **Plocquet test**
 - Proportion of lung weight by body weight.
 - Without respiration - 1/70.
 - Respiration - 1/35 of body weight

4. **Breslau's 1st life test**
 - Air in the lung
5. **Breslau's 2nd life test**
 - Air in the stomach or intestine.
 - Stomach/ bowel test
 - Double ligate the stomach and cut between two ligatures.
 - Put stomach in water.
 - Open the stomach inside the water
 - If air present → Bubbles will form

Breslau's 1st life test

- Lung float test
- RAYGAT'S test
- Hydrostatic test
- Specific gravity of water - 1
- Specific gravity of non-respired lung - 1.04
- Specific gravity of respired lung - 0.94
- If Specific gravity is less than 1 → substance floats
- If Specific gravity is more than 1 → substance sinks

Breslau's 1st life test

- Based on specific gravity.
- Based on the residual volume.
- Residual volume
 - Volume of air that cannot be expired even with forceful expiration.

Steps

Tie bronchi
Put lung in a bucket of water
If lung pieces float - may have respiration
↓
Simultaneously do the **Control test**
Put liver in the bucket.
prince kumar
princeeeekum@gmail.com
992910971
Normally liver sinks as the liver is solid.
If the liver is floating -
it is a case of putrefaction due to gas in the organ.
Then the hydrostatic test is invalid.

If liver sinks
↓
Simultaneously put **12-20 pieces of lung**
If still floating go for the next step
↓
Squeeze lung pieces between thumb and index finger or stone
to remove tidal air.
If still floating it is due to residual volume
Positive hydrostatic test

If only some pieces float - may be feeble respiration

False positive

- Respiration was absent.
- But lung pieces are floating.
- **Putrefaction**
 - Can be ruled out by taking Liver as control.
- **Artificial respiration**

False negative

- Fetus respired.
- But still lung pieces are sinking.
- Pneumonia
 - Inflammatory solid patches
- Alveolar duct membrane.
- Pulmonary edema
- Collapse of alveoli - atelectasis.
- Complete absorption of air by lung.

A hydrostatic test is not necessary for

- Non-viable foetus <28 weeks
- If the fetus is Dead born
 - Maceration
 - Mummification
 - Monster fetus - Congenital anomaly
 - Anencephalic fetus cannot survive.
- If clear-cut case of live born
 - Milk is present in the stomach.
 - Umbilical cord separated.
 - Umbilical scar (usually seen after 1-2 weeks)

Few more signs of live birth

- **Caput succedaneum**
 - Edema or congestion of the scalp.
 - **Crosses suture line.**
 - Compression of the scalp.

Tip to remember

Caput succedaneum

- **Pit present**
- **Successful in crossing the suture line**
- **Cephalhematoma**
 - Hematoma between periosteum and skull
 - **Does not cross suture line.**
 - Subperiosteal hematoma
- **Umbilical structures**
 - Umbilical artery closes on 3rd day.
 - Form medial umbilical ligament.
 - Vein closes 4th day.
 - Form ligamentum teres
 - Cord - falls by 5-6 days.

Tip to remember

Umbilical structures

AVC

- Artery - 3rd day
- Vein - 4th day
- Cord - 5-6 days

Criminal abortion

- Section **312-316 IPC**

Tip to remember

- **Criminal Abortion**
- **CAB = 312**

S.317 IPC

- Abandoning the child at any place below 12 years of age.

S.318 IPC

- Concealment of birth.
- 2-year ± fine.

Tip to remember

- **317,318 IPC -**
- **ABC**
- **317 - AB - abandoning**
- **318 - C - concealment**

- If child is unborn

- **Vagitus uterinus** - intrauterine cry of unborn child.
- **Vagitus vaginalis** - Intravaginal cry.

SIDS

Sudden Infant Death Syndrome

- Infant was healthy.
- Unexplained sudden death.
- **Crib death**
- **Cot death**
- **Negative autopsy**
- Predisposing factors
 - common in males
 - 2 weeks to 2 years
 - Commonly in infants less than 6 months
 - Incidence - 0.2 - 0.4%
 - If 1st twin has problem, 2nd twin has more chance.
 - Usually - Early morning
 - If mother or parents are smokers or alcoholic
 - Prematurity
- Autopsy - Negative autopsy
 - All gross, Histopathologic, and laboratory tests are done.
 - No findings
- Face - cyanosis
- Milk or blood-stained froth from the oral cavity and nostrils
- Petechial hemorrhages in organs.

Dr. P. K. Kumar
princeeekum@gmail.com
9928609733

- Cause of death
 - Deficiency of calcium, magnesium, selenium
 - Most common accepted theory - **prolonged sleep apnoea**
 - Viremia → respiratory depression.
 - Cow milk allergy.
- Medico Legal implication
 - Presumed to be case of infanticide.

Munchausen Syndrome of Proxy

01:08:17

- Example of child abuse
- Parents have psychological problems.
- Repeated frivolous complaints by the parents.
- Unnecessary investigations and treatment.
- May be produced or alleged by parents.

Examples

- Parents give laxative and complain of diarrhoea.
- Parents give emetics and complain of vomiting.
- Prick finger and mix with urine to cause hematuria.
- Give Insulin → hypoglycemia

Criteria

ROSENBERG criteria

1. Illness produced for alleged by parents.
2. Repeated medical procedures and treatments.
3. Denial of knowledge of cause of symptoms
4. Regression of symptoms when child is separated from parents.

Battered Baby Syndrome

01:12:17

- Also called **Caffey Syndrome**
- **Caffey Kempe Syndrome**
- **Maltreatment syndrome**
- **Parent Child Stress Traumatic Syndrome**
- Inflicted physical injury by parents or guardian.

DDD

- Discrepancy in injuries on body and history given by parents.
- Delay in production of injuries and seeking medical attention.
- Different stages of healing of injuries.
 - Some injuries are 1 day old.
 - Some 1 week
 - Some 1 month
- **Predisposing factors**
 - Common in children < 3 years
 - Male child
 - Eldest or youngest child.
 - Unwanted or illegitimate child.
 - In parents of low socioeconomic status.
 - In illiterate parents.
 - Unemployed parents.

- Unmarried parents.
- If parents are Smokers or alcoholic or drug abusers.
- Same history in parents - Parent was a battered baby.

Injuries

- Most common method of injury
 - Direct manual violence - Direct hitting
- Most characteristic lesion
 - When you close mouth while crying or slap the child.
 - Causes **Tear inside upper lip near frenulum.**
- Others
 - Eye injuries
 - Retinal haemorrhage or detachment.
 - Patterned bruises.
 - Pinch marks → **Butterfly bruises**
 - Fingertip pressure → coins shaped bruises or **six-penny bruises.**
 - Burns or scalds.
 - Hands or leg or feet in hot water.
 - **Glove and stockings pattern of injuries.**

Infantile whiplash syndrome

- **Shaking baby syndrome**
 - Frequent shaking of baby
 - Causes **Subdural hematoma.**
 - Due to rupture of bridging veins
- Retinal detachment
- Periocular bleeding
 - **Dot and blot haemorrhages**
- Encephalopathy

prince kumar
princeeeekum@gmail.com
9928609733

- Skull fracture - linear fracture or fissure fracture.
 - **Eggshell fracture**
- Multiple rib fractures
 - Anteroposterior compression → lateral fracture of ribs in midaxillary line
 - If lateral compression → ribs fractured at posterior angles.
 - **Paravertebral gutter formation - called nobbing fracture.**
 - X-ray - Formation of callus - **String of bead appearance.**
- Metaphyseal fracture
 - Lower end of tibia
 - Upper end of femur
 - **Corner fracture or bucket handle fracture**
- Traumatic alopecia - Subgaleal hematoma

Cause of death

- Most common cause of death - Head injury
- Followed by blunt trauma to abdominal organs.

Investigation

- A single X-ray of whole body - **Babygram**
- Most characteristic lesion - tear inside lip near frenulum
- Most common cause of death - Head injury



CROSS WORD PUZZLES



Crossword Puzzle

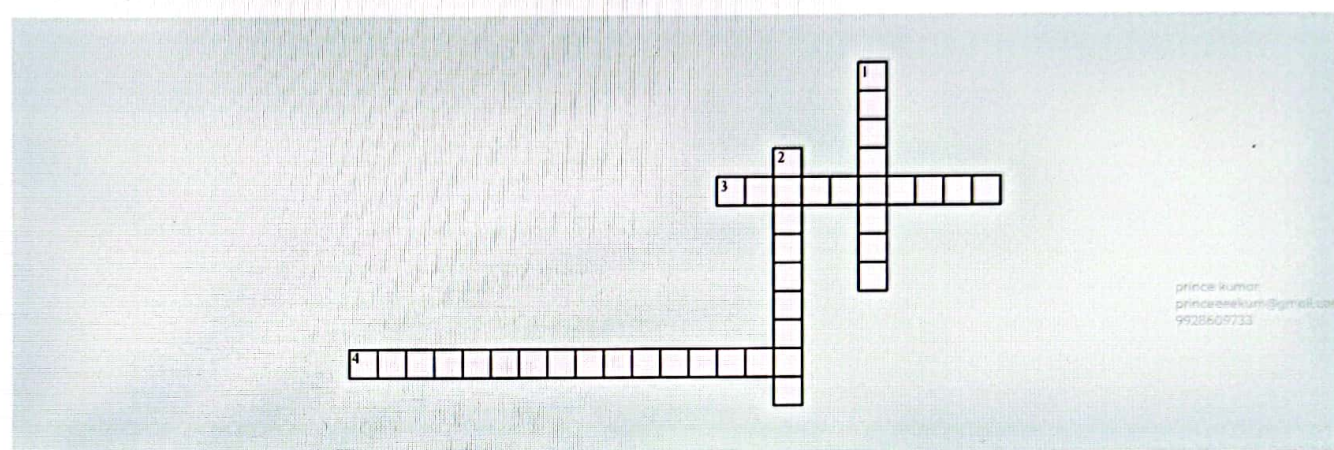

prince kumar
princeeeekum@gmail.com
9928609733

Across

- 3. Foetus died during the process of delivery
- 4. Hyperflexion of Spine

Down

- 1. Foetus died inside uterus
- 2. Any sign of life after complete birth of child

prince kumar
princeeeekum@gmail.com
9928609733



11

ASPHYXIAL DEATH

- Meaning: Pulselessness (exactly it is O2 supply stopped)
- Another word for it is known as Hypoxia.

Sign of Asphyxia: Death

00:00:56

- CPC (Classical triad of Asphyxial death)
 - Cyanosis:**
 - It is peripheral. It is m/c seen in the Nail bed, Ear, and Nose.
 - The reason for this is Deoxy Hb > 5gm%.
 - Also, the structure becomes blue.
 - Petechial Hemorrhages:**
 - These are pin-point hemorrhages.
 - The size is 0.1-2 mm (>2mm is Ecchymosis).
 - The reason is due to asphyxia, the pressure in capillaries increases which leads to damage in Capillaries & Venules.
 - The common sites for it are the Eyelids, Conjunctiva, Forehead, Visceral Pleura, and visceral peritoneum.
 - Congestion:**
 - It is visceral congestion.
 - Liver, lungs, and heart are involved.
 - The mechanism is increased permeability of capillary.
 - Other (not classical)**
 - Right Ventricular Enlargement
 - PM fluidity of blood

Types of Asphyxial Deaths

00:06:04

1. Hanging
2. Strangulation
3. Suffocation
4. Drowning

Post-mortem

- There is a modified Y dissection.
- Neck dissection should be done last because we want the neck bloodlessness field.
- This is to avoid Prinsloo & Gordon Artifact (hemorrhage on the anterior aspect of the cervical spine, Posterior to the trachea and Esophagus).



Tardieu Spot in Eye

- Also, known as Bayard Spot
- It is Petechial. Hemorrhage.
- It is mainly seen in Visceral Pleura, Peritoneum.
- Mechanism is Increased Acute rise in venous pressure

1. Hanging: m/c asphyxial method

00:09:55

- Suspension of the body with Ligature that encircles the neck.
- Constricting Force: Weight of the body.
- **Types:**
 - **Suicidal:m/c in India**
 - **Homicidal: rare**
 - This method is known as lynching (A group of people hangs up someone)
 - **Accidental: not very common.**
 - **Judicial:**
 - It is the method of the death penalty in India.



Types - Position of Knot:

- Typical: if the position is on Occiput.
- Atypical: it is the position of the knot at any other place.

Types- Suspension:

- **Complete:**
 - It means the whole body is suspended. No part is touching the ground.
 - Constricting Force here is whole body weight.
- **Incomplete:**
 - Also known as Partial hanging
 - Here, some part of the body is touching the ground.
 - Constricting Force here will be the weight of the head (around 4-5 kg).

Structure-Pressure Needed-COD

Structure	Pressure needed	Cause of death
Jugular Vein	2 kg	Venous congestion.
Carotid artery	5 kg	Cerebral Anaemia/ Anoxia.
Trachea	15 kg	Asphyxia.
Vertebral artery	25-30 kg	Many damages.

princeekum@gmail.com
9928609733

M/c Cause of Death:

- Asphyxia + venous congestion (in hanging)

- **Others:**
 - Carotid artery damage leading to cerebral Anoxia.
 - Reflex vagal inhibition.
 - Fractures or dislocation of vertebrae.
- **Delayed cause:**
 - HIE (m/c cause)
 - Aspiration Pneumonia
 - Larynx Edema
 - Infections
- The fixed knot Ligature mark is oblique. It is an incomplete Ligature.
- If the knot is slippery & we have the running noose, and the Ligature mark is transverse. It could be complete.
- **PM finding:**
 - **External:**
 - **Ligature Mark: Most Specific finding**
 - It is Pressure Abrasion.
 - Sometimes it forms a pattern, so it can be patterned abrasion.
 - In up to 85% of cases, it goes above the thyroid & in 10% at the thyroid the remaining 5% below the thyroid.
 - Complete/incomplete (depends on): Knot.
 - CPC
 - Face is deeply congested in partial Hanging because there is blockage of venous congestion & arterial supply is intact.
 - **Staining:** It is seen in the upper limb & lower limb, known as the Glove and stocking pattern.

Ligature Mark

00:27:28

- **Pale, White, Glistening (Parchment).**
 - **Internal:**
 - After dissection of the ligature mark, we find a white & glistening area.
- **Amussat's Sign**
 - It is seen when you have a long drop.
 - Common in judicial hanging.
 - There is a horizontal or transverse tear in the carotid artery.
- **Simon's Hemorrhage:**
 - Hemorrhage into the outer layer of the intervertebral disk of the lumbar and lower thoracic vertebrae (below the anterior longitudinal ligament).
- **Dribbling of Saliva**
 - M/c finding of AM hanging (died due to hanging).
 - Not present in every case.
 - It is due to stimulation of the Pterygopalatine Ganglion (submandibular gland).
 - Opposite side of the knot.

- **La Facies Sympathique**
 - Important finding of AM hanging
 - Due to stimulation of the cervical Sympathetic chain by a knot.
 - On the Same side of the knot, the eye remains open & pupil is dilated.
- **Fracture of Neck:**
 - It is the fracture of the hyoid bone.
 - At the junction of inner 2/3 rd & outer 1/3 rd
 - This fracture is known as abduction or outward or anteroposterior compression fracture.
 - It is Antemortem: if the surrounding tissue has a contusion, Hemorrhage
 - Fracture of the Superior horn of the thyroid can be seen.



- **Sexual Asphyxia / kotzwainism-partial hanging:**
 - Accidental hanging
 - Very common when you are having partial hanging.
 - It is seen in masochism.
 - Generally naked in opposite-sex Clothes (transvestism)
 - Pressure on the carotid artery which causes cerebral ischemia leading to erotic hallucination.
 - If orgasm is there, you will release the patient.
 - If it becomes persistent pressure, it becomes accidental death.
 - Common in young males.
 - Person will be in the bathroom, naked with some pornography material and semen discharge.
- **Judicial Hanging:**
 - Death penalty in India
 - Person is standing on a Platform that is suddenly moved and a long drop is caused.
 - Hangman Knot:

- Ideal site is below the chin, submental.
- In India, the site is the left lateral side (sub-aural) at the angle of the mandible.
- Causes hyperextension of the neck leading to Hangman's fracture (main C2 / axis vertebrae fracture).
- Leads to Brain stem damage causing instantaneous death.

2. Strangulation

00.42.32

- Only constriction of the neck & no suspension.
- **Types:**
 - a. Ligature
 - b. Manual:
 - By hand & known as Throttling.
 - And only stimulated by palm, so Palmar strangulation.
 - c. Bend of Elbow/Forearm: Mugging
 - d. Bamboo Sticks: Bansdola
 - e. Garroting:
 - Common in Spain, and Turkey.
 - This is judicial strangulation.

Garroting



- It is known as Spanish windlass method.
- There is a lever that causes constriction of the neck.

Ligature strangulation

- **Cause of Death:**
 - A-Asphyxia
 - C-Cerebral Anoxia
 - V- Vagal inhibition leading to cardiac arrest.
 - F- Fracture
- **PM findings**
 - External:
 - Ligature marks are generally transverse and complete.
 - Level: either at the level of the thyroid or below the level of the thyroid.
 - Peri-ligature injuries and hemorrhages are seen.
 - Asphyxial signs: CPC (more prominent).

- Face: congested
- Petechial hemorrhage- present in face
- Subconjunctival hemorrhage present & bleeding from Nose and mouth can be seen.
- Signs of struggle: injuries on the body.

- Internal:
 - On dissection of ligature mark, there will be contusion & Hemorrhage of tissue, neck of muscle, tonsil, and gland.
 - Fracture of the thyroid is most commonly seen.
 - Hyoid bone fracture is generally not seen because it is at or below the level of the thyroid.

Ligature Strangulation



prince kumar
princeeeekum@g
9928609733

- **Throttling:**
 - Always Homicidal.
 - Thyroid fracture & hyoid bone fracture (30-50% cases) is present.
 - External findings:
 - Abrasion of the nail, neck semilunar, crecentric over the neck (important finding)
 - Bruises: Oval or round shaped because of fingertip pressure. These are known as Sixpenny Bruises (like coin shapes).
 - Face congested.
 - Petechial hemorrhages present.
 - Subconjunctival hemorrhages present.
 - Bleeding from mouth and nose.
 - CPC
 - Internal findings:

prince kumar
princeeeekum@gmail.com
9928609733

→ On dissection of the neck, Bruises/contusions of different neck muscles present

→ Hyoid fracture is an example of adduction fracture or inward compression.

→ Cricoid fracture is very rare but specific.

○ Hyoid fracture most common in throttling > hanging > Ligature strangulation.

○ Thyroid fracture is most common in Ligature strangulation.

3. Suffocation

00:56:30

• No neck compression, no suspension but it is a blockage of the airway.

• Purest form of asphyxia with CPC always present.

Methods of Suffocation:

• Smothering:

○ Blockage of mouth and nose

○ In PM, CPC, Abrasion (face, semilunar, crescentic), contusion (mouth & lips), laceration (tear in frenulum of lip)

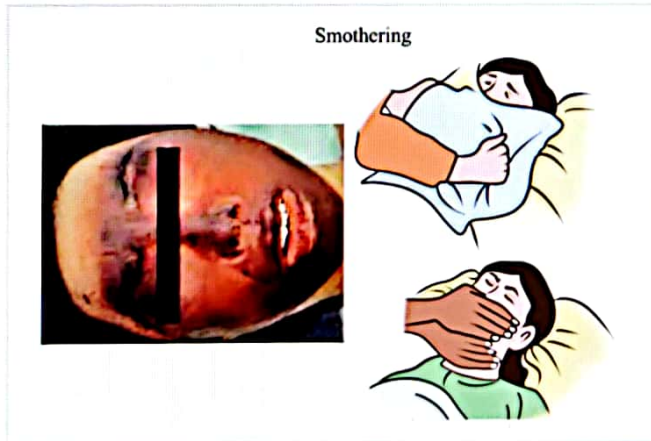

→ 1st image of smothering

→ 2nd and 3rd image of Smothering by pillow and hand image.

→ After dissection of this contusion, there will be a hematoma or hemorrhage.

• Choking:

○ It is by any object airway is blocked.

○ common in children.

○ Ex- By coin.

○ Most of the time, it is accidental.

○ The Heimlich manoeuvre (holding the epigastrium with upper & inward pressure) can be used for choking.

• Gagging:

○ It can be a cloth piece that is put in the mouth but sometimes the cloth piece goes to Oropharynx and blocks the oropharynx & nasopharynx & airway.

○ It is always Homicidal.

• Café Coronary:

○ Term was given by Roger Hougen

○ Seen:

→ If you are intoxicated & eat food that acts as a bolus and goes to Larynx / Pharynx where it causes mechanical Asphyxia.

→ But the cause of Death is reflex vagal inhibition leading to cardiac arrest (cause of death).

→ Happens because when intoxicated, cough reflexes are inhibited.

○ Common in restaurants.

• Traumatic Asphyxia:

○ Known as Perthe's Syndrome.

○ Due to trauma → chest fixed & not able to respire.

○ Seen in earthquake-leading building collapses = Stamped

○ Masque ecchymotique: Line of Demarcation.

• Positional Asphyxia

○ Jack-knife position

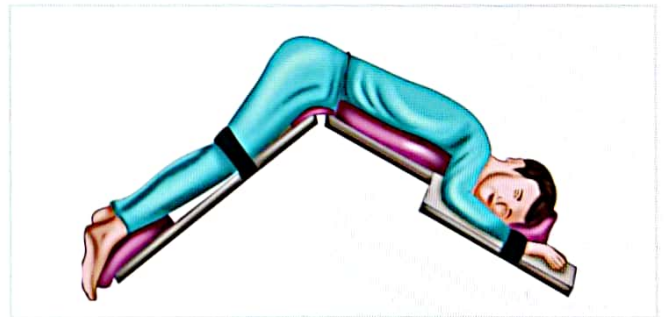

• Because of compression the lower area compresses the diaphragm & you won't be able to respire.

• Inverted Crucifixion

• Overlaying

○ Suppose a mother sleeping beside a child comes over the child, then the face will be occluded leading to smothering. This is known as overlaying.

• Burking

○ Word was given by William Hare & Burk.

○ They killed 16-18 people and were sent as a cadaver to an anatomist (R. Knox)

○ Burking = Traumatic Asphyxia + Homicidal smothering



→ Sitting on the chest and smothering is burking.

- **Wedging**

- If any child comes between 2 surfaces & not able to respire is Wedging

4. Drowning

01:13:00

- It is the immersion of the body in water or liquid.
- M/c, it is accidental > suicidal > Homicidal.

Types of Drowning:

1. Wet Drowning / Typical Drowning / Primary Drowning:

- In this, water goes into the lungs.
- If less water (3-4 ml/kg) goes into the lungs, it causes loss of Surfactant leading to a Collapse of alveoli → Cerebral Hypoxia → Death.
- If water goes into the lung is more (10/12 mg/kg), there are two types:

→ Freshwater Drowning:

- Hypotonic fluid → Pulmonary Capillaries → Hemodilution.
- To neutralize fluid, RBCs are lysed and liberate K⁺ causing Hyperkalemia.
- Hyperkalemia causes ventricular fibrillation → Cardiac arrest.
- Fatal period is 5 min.

→ Sea / Saltwater Drowning (contains Na, Mg, Cl):

- Hypertonic fluid → Pulmonary Capillaries → Hemoconcentration
- Pulmonary Edema presence which comes to Alveoli from blood
- There will be Hypernatremia.
- Can cause bradycardia & cardiac arrest.
- Respiratory distress because of edema.
- Fatal period is 10 min.

2. Dry Drowning

- Water does not enter the lung, but it causes reflex laryngospasm (due to vocal cord Spasm)
- It is an atypical Drowning.

3. Hydrocution

- Also known as Submersion or immersion syndrome, cold water Drowning.
- Shock treated by water (cold water 5°C or below).
- Water touches the ear, skin, nasal area, and epigastrium (sensory nerve endings stimulated).
- Causes reflex vagal inhibition → cardiac arrest.

4. Near / Delayed / Secondary Drowning / Post Immersion Syndrome:

- Death due to delayed complications such as Pneumonia, Metabolic acidosis, electrolyte imbalance, and encephalopathy.

PM Finding (Specific)

- **AM Drowning: Died in Water**

- External:

- Cadaveric Spasm (m/c sign): Clenched hand with grass particle. Indicates struggling in the water. After death, the hand remains spasm.
- Water → airway → mucoid froth (water + mucus + air).

Cadaveric spasm

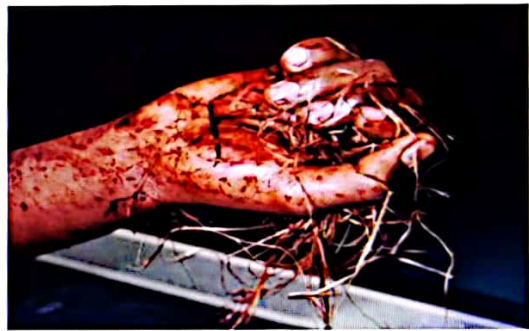

- This effect is known as a churning effect.
- Features of froth include fine, white, leathery, tenacious, and copious from nose and mouth.
- Froth without mucus is seen in deaths such as snake/opium poisoning, electric shock, epilepsy death, putrefaction and pulmonary edema.

Drowning



- Internal

- Lungs are Voluminous with Rib Marking.
- Emphysema Aquosum is seen in conscious people.

- Froth is present because there is mucus (Frothy water).
- Lung shows marbled appearance (alveoli ruptured, damaged, thin).
 - Edema Aquosum is seen in an unconscious person (passive filling of water in the lung)
- Froth is not present here as no mucus is present.

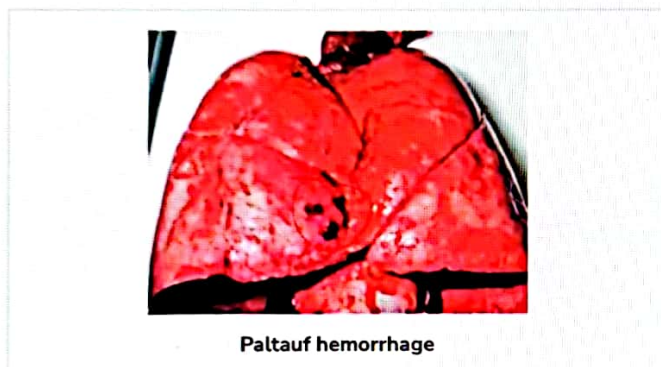

- Subpleural hemorrhage.
- Mainly because of forced expiration → Alveoli ruptured.
- Mainly on the anterior lower lobe at the margin.
 - Mud particle & water present in stomach & small intestine.
 - Mud particle in Trachea is also a specific finding.
- **PM Drowning: Died outside & body is then put into water.**

Signs

- **Sehrt's Sign:**
 - Micro Rupture in Gastric Mucosa.
- **Sveshnikov's sign:**
 - Free liquid in the paranasal sinus.
- **Sabinsky's Sign:**
 - Small and anemic Spleen.
- **Ueno's Sign:**
 - water in the middle ear with Hemorrhage.
- **Wydler's Sign:**
 - Gastric content in a container with three layers (Foam, liquid, solid) forming a ring.
- **Drowning Index:**
 - Weight of both lungs + weight of pleural effusion / Weight of spleen
 - If > 14.1%, it suggests AM drowning.

Non-specific signs

Can be present in AM Drowning as well as PM Drowning

- **Cutis Anserine:**
 - Due to contraction of the Erector Pili muscle leading to granular / puckered skin.
 - Contraction of the erector Pili muscle can also be a feature of Rigor-mortis.
- **Washer woman hand:**
 - If the body is in water for a long time, change in the skin of the Palm, and sole is seen due to Imbibition.
 - Wrinkling (2-3hr), Soddening (12hr), Bleaching (12-24hr), Peeling / Degloving (3-4 days)

prince kumar
princeekum@gmail.com
9928609733

DIATOM

- It is present in water.
- Unicellular algae.
- **Types:**
 - Oligo Halophilic: Present in freshwater.
 - Polyhalophilic: Present in Seawater.
- Covered by Wall composed of silica (hard layer)
- Resists Putrefaction
- Goes with water in the body → penetrates pulmonary capillaries & goes to systemic circulation → To different organs.
 - DIATOM around 60 microns can penetrate the pulmonary Capillary.
- Best organ for detection is Bone marrow (of the femur & sternum).
- Best Viscera is the spleen.
- Acid Digestion Test is done by using nitric acid.
- DIATOM remains intact because it is covered by silica.
- Suggestive of AM Drowning.

Gettler's Test

- Chloride Ion test for heart chamber.
- Normally left chloride ion concentration is equal to the right.
- If the difference is more than 25%, it suggests that it's AM Drowning
- Fresh water: Right side concentration > Left.
- Sea water: Left side concentration is > Right.
- Not useful in Putrefaction or Patent Foramen Ovale or Dry Drown.
- High levels of serum strontium (most significant) and magnesium in the left ventricle are indicators of Seawater Drowning.



PREVIOUS YEAR QUESTIONS



Q. A person was found dead. Post mortem shows nail scratches in the face, lip laceration in the inner side of the lip. Hypostasis is fixed. Which of the following cannot be the reason? (FMGE Dec 2020)

- A. Cause of throttling
- B. Post mortem was done with 24 hours
- C. Due to asphyxia
- D. It is Homicide

Q. Gettler's test is positive in?

- A. Hanging
- B. Poisoning
- C. Strangulation
- D. Drowning

(FMGE-May-2018)

Q. True about freshwater drowning? (INICET-NOV-2020)

- A. Hemodilution
- B. Hypokalemia
- C. Hyponatremia
- D. Arrhythmia

prince kumar
princeekum@gmail.com
9928609733



CROSS WORD PUZZLES



Crossword Puzzle

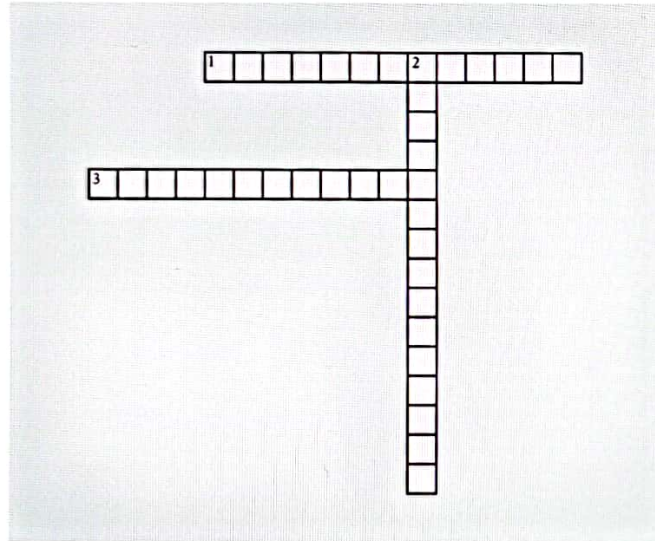

Across

- 1. Asphyxial Death
- 3. It is seen when you have a long drop

Down

- 2. Hemorrhage into outer layer of intervertebral disk of lumbar and lower thoracic vertebrae

12

ROAD TRAFFIC ACCIDENTS



Topics

- Motorcyclist injuries (accident while riding a bike)
- Pedestrian injuries (accident while walking)
- Vehicle injuries (accidents involving big vehicles)
- The nature or severity of the injury depends on

To Remember

- Speed of vehicle
- Point of impact

prince kumar
princeeeekum@gmail.com
9928609733

1. Motorcyclist Injuries

00:01:33

Motorcyclist fracture

- Motorcyclist fracture is also a type of regional injury (dealt in the Regional injuries chapter).
- Site: Base of the skull (BOS).
- It is a **type I hinge fracture**.

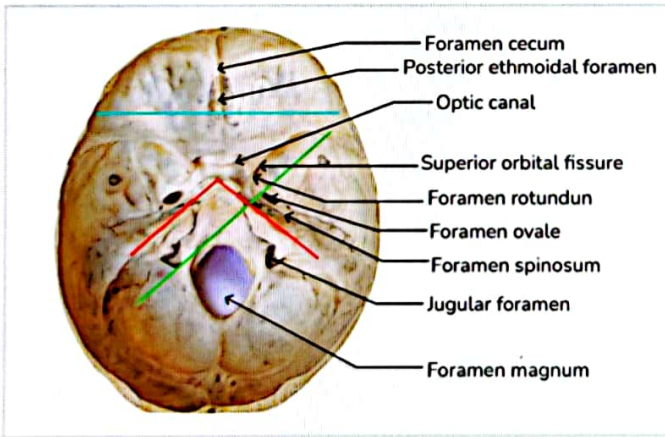

- **Pattern:** Petrous site → Sella turcica → Petrous ridges.
- Motorcyclist fracture divides the skull into **2 halves**.
 - Anterior
 - Posterior
- It is a **side-by-side fracture** (force is from one side and it goes to the other side).

Other Fractures of the BOS

- Type 2 - Green line.
- Type 3 - Blue line (which is in the coronal plane)

Tail gating/ Under Running

- Running into a large/ heavy vehicle from the back.
- **Example:** If any motorcyclist or a person is crushed to the back of a truck/car.
- Head injury is the most common.
- Can also lead to **decapitation of head/** removal of the face or chest or abdomen.

2. Pedestrian Injuries

00:06:00

- Person walking or standing on the road can meet with an accident.

Types of Pedestrian Injuries

- **Primary Impact Injury**

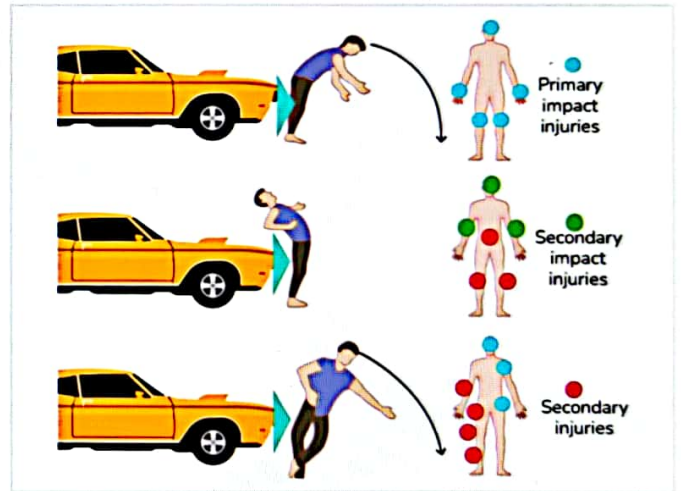

- Most common site: Leg
- **Secondary Impact Injury**
 - Hitting by the **same vehicle 2nd time** (or 2nd contact injury).
 - Person moves over the vehicle.
- **Tertiary Impact Injury**
 - Also called secondary injuries.
 - Injury due to impact with an object **other than the same vehicle**.
 - **Objects:** Road, divider, other vehicles, pole.

a. Primary Impact Injury

- Bumper of the vehicle is the main object, so the most common injuries are bumper injuries.
- Injuries due to bumper
 - Abrasions
 - Contusions
 - Lacerations
 - Fractures
- **Most common site:** Leg.
- **Adults**
 - Leads to bumper fracture
 - **Most common:** Tibia bone fracture.
 - Mostly on the lateral side of the tibial plateau.
 - **Wedge/triangle-shaped fracture.**
 - **Other parts:** fibula, femur (rarely).

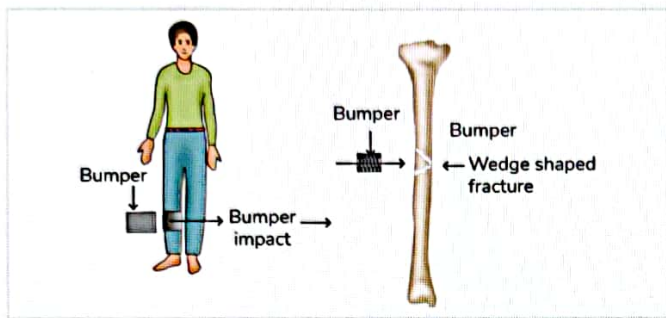

- **Base** is a point of impact (triangle shape)
- **Apex** is the direction of impact (car/ vehicle)
- **Common sites**
 - Leg (tibia) - Adult
 - Femur - Children (as they are short)
- **If the bumper fracture is from the back side-** the vehicle is coming from the backside.
 - **Vehicle movement and location of the injury**
 - **Right to Left** - Lateral aspect right side of the leg
 - **Left to Right** - Lateral aspect left side leg
- **If the bumper fracture is from the front side-** the vehicle is coming from the front side.
- **Victim standing-** Injuries will be at the same level on both legs.
- **Victim running or walking -** Injuries will be at different levels on both legs.
- **Height of injuries**
 - Usually at the same height as the bumper.
 - If the vehicle is speeding (accelerating) - **Higher than the bumper.**
 - If the vehicle applied breaks - **Lower than the bumper.**

b. Secondary Impact Injury

- **Cause:** 2nd contact of the same vehicle.
- Victim may hit the Bonnet or Windshield.
- **Possible injuries**
 - Can lead to multiple injuries.
 - **Most common:** Head injuries.
 - **Other**
 - Cervical fracture or injury
 - Skeletal injuries.



C. Tertiary Impact Injury

- Also known as Secondary injuries.
- Hitting other objects.

- **Cause:** May hit the road or get dragged on the road.
- **Possible injuries**
 - **Most common:** Head injuries.
 - Skeletal fractures

Q1. Multiple grazed abrasions and lacerations are due to?
Ans. Getting dragged on the road.

Types of Tertiary Impact Injury

- **Roll-on or Roll-over injuries** (victim rolling on)
 - Caused by vehicles **having low chassis.**
 - **Example:** Car/ Small vehicles like auto.
 - **Characteristics**
 - **Grazed abrasions** - around the circumference.
 - **Fractures** - Of bones.
 - **Patterned abrasions**-Due to the Chassis of the vehicle.
 - **Burning of skin** - Due to hot exhaust.
 - **Grease stains** - Due to grease from the car.
- **Runover injuries** (vehicle runs over)
 - Caused by vehicles **having high chassis.**
 - **Example:** Heavy vehicles like trucks and lorries.
 - **Characteristics**
 - **Tyre marks**-Most specific (patterned abrasions/bruises).
 - **Grazed abrasions** - Multiple abrasions on the body due to friction.
 - **Avulsion** - Separation of tissue (shearing lacerations).
 - **Crushing injuries**-Crushing of head or body or internal organs.
 - **Burning of skin** - Due to hot exhaust.
 - **Grease stains** - Due to grease from the car.

3. Car Occupant Injuries

00:24:36

- Car has 2 occupants
 - Driver
 - Front seat passenger
- a. Car Driver Injuries**
- i. Windshield Injuries**
 - Leads to Sparrow feet mark (driver is ramming in the glass)
 - Dicing injury (broken glass will fall on the driver)

What happens?

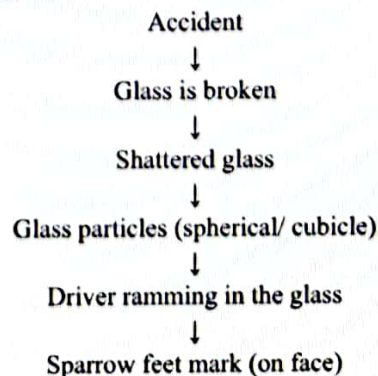

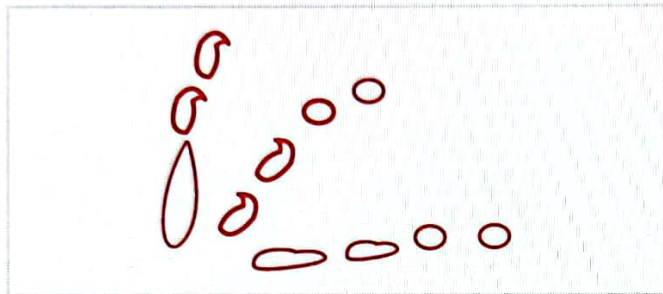

Sparrow feet mark: It is a multiple, small, superficial punctate laceration.

- **Not very common** - As the driver usually wears a seat belt.

Sparrow Foot Mark	Dicing Injury
Not common	Common
Sparrow foot mark is mainly on the face	Can be on both the face and body
The driver is ramming into the glass	Broken glass will fall on the driver

ii. Neck Injuries

- **2 types**
 - Whiplash injury (soft tissue injury)
 - Neck fracture (cervical)
- **Reason:** Violent neck movements.
- **Whiplash injury**
 - **Acceleration**-Hyperextension of the neck followed by hyperflexion.
 - **Deceleration**-Hyperflexion of the neck followed by hyperextension.

To Remember: More common and dangerous in a Whiplash injury is Hyperextension.

- **Injuries:** Contusion of the soft tissue of the cervical spinal area (fatal).
- **Level:** C5, C6 level.
- **Common site:** Anterior longitudinal ligament.
- Anterior longitudinal ligament and cervical ligaments are torn.

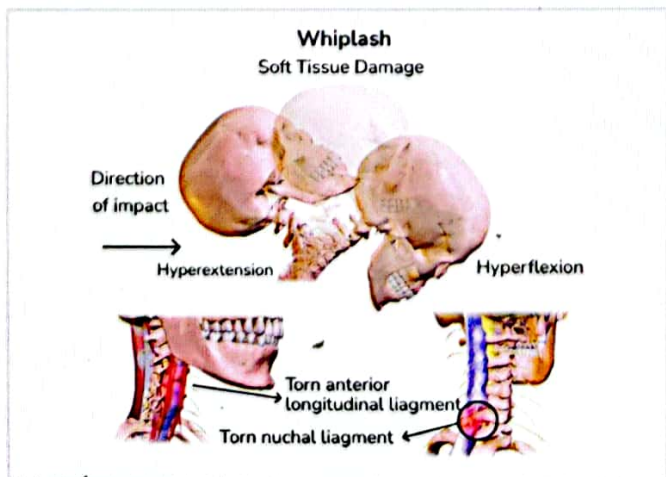

iii. Steering Wheel Injuries

- **Sites**
 - Steering injury - Sternum fracture.
 - Steering injury - Ribs fracture.
 - Other sites: Elbow or forearm.
 - Chest-The most common site for Patterned Bruises.
- **Organs involved**
 - Lung
 - Heart
 - Aorta
- Direct impact on the aorta shows **Torsion force**.
- Part involved is the isthmus (distal to the subclavian artery).
- **Ladder rung tear:** There will be a transverse tear in the intima of the isthmus.
- **Osseous punch:** There will be compression between the sternum and thoracic vertebrae.

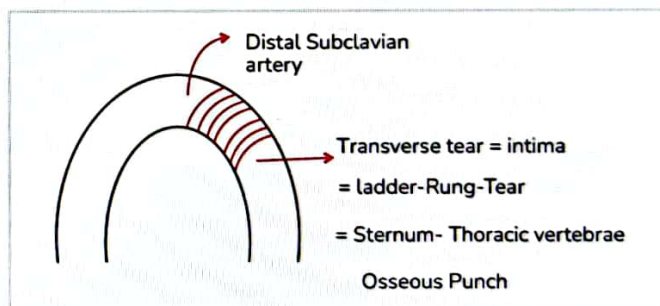

- **Deceleration injury** - Stretching or straining of aorta.

iv. Seat Belt Injuries

Seat belt syndrome, has 3 categories

- **Seat belt sign (Patterned bruise)**
 - In drivers it starts from the right shoulder.
 - In the front passenger it is from the left shoulder.



• Intra-abdominal injuries

- Due to deceleration and compression.
- **Common sites**

- Mesentery (most common)
- Small intestine-Duodenojejunal flexure (primary), ileocecal junctions (secondary)
- Liver

- **Vertebral injuries**

- Due to distraction and compression.
- **Distraction** (separation of the joint)
 - If only lap belt-Hyperflexion of the spine (lumbar vertebra).
 - Seen on the posterior side
- **Compression**
 - Seen on the anterior side

Chance\ Fulcrum fracture: Distraction on posterior side + Compression on anterior side → Posteroanterior fracture of vertebra (transverse fracture).

- Seat belt syndrome=Seat belt sign + Intra-abdominal injuries + Vertebral injuries

- b. Front Seat Passenger Injuries**

- All driver injuries are seen in the front seat passenger (except the steering injury).
 - Windshield (sparrow foot sign, dicing injury)
 - Whiplash injury (cervical injury, soft tissue injury)
 - Seat belt injury (patterned bruise in the front passenger, starts from the left shoulder)
 - Instead of steering injury, we can see dashboard injury.

Dashboard Injury

Front seat passenger is sitting in a position, where the knee and hip are flexed

prince.kumar
princeekum@gn
9928609733

↓
Accident

↓
The dashboard will hit the flexed knee

↓
3 P's

Patella fracture/Posterior cruciate ligament injury/Posterior dislocation of the hip

- **Dashboard dislocation:** Posterior dislocation of hip due to dashboard injury.
- **Most common nerve:** Sciatica nerve.
- Sometimes **femur damage** is also seen.

- Q. Why only posterior dislocation of the hip and not anterior in dashboard injury?
- Q. Why is posterior cruciate ligament injury more common in dashboard injury?
- Q. Why is anterior cruciate ligament injury less common in dashboard injury?

Ans. In the sitting position, the anterior cruciate ligament is relaxed and posterior cruciate ligament is taut.



CROSS WORD PUZZLES



Crossword Puzzle

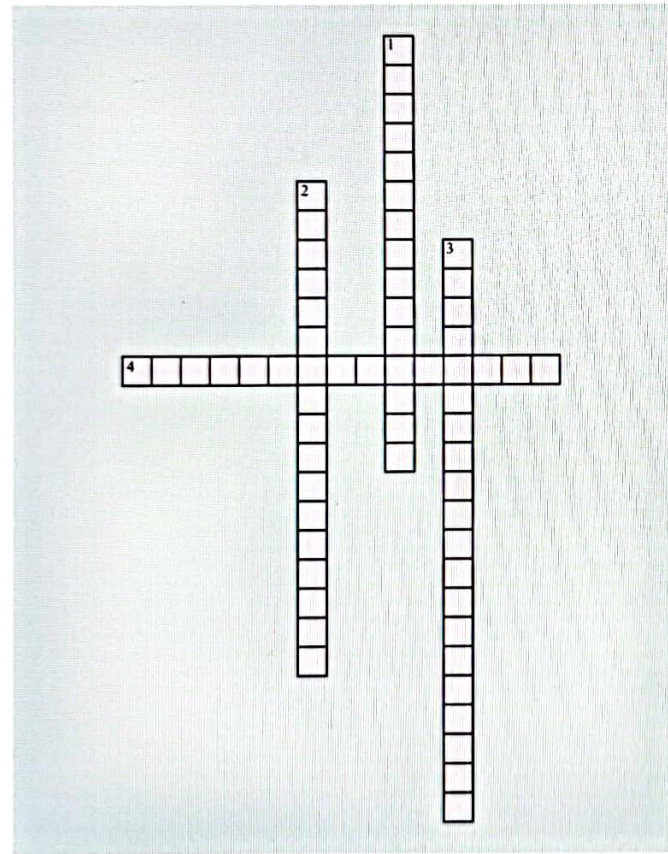

Across

4. Caused by vehicles having high chassis

Down

1 Front seat passenger is sitting in a position, where the knee and hip are flexed

2 Due to distraction and compression.

3 It is a type I hinge fracture

13

THERMAL INJURY



Hypothermia

00.00.02

- It happens when the temperature goes below 35°C.
- It happens in old age people, alcoholic people, and in people with diseases.

Signs:

- Clouding of consciousness
- Disorientation
- Loss of Reflex
- Respiratory rate, heart rate, and blood pressure becomes low.

Hypothermia postmortem finding after death

Skin becomes

- Pale that is why it is also known as white death
- Postmortem lividity: bright-pink
- Stomach mucosa: black-brown necrosis (wischnewski-spot)
- Fat necrosis: Pancreas (50% people)
- Lipid depletion: Adrenal gland
- Internal organs: Congested

Hypothermia has 3 phenomenon:

1. Skin: Erythema pernio, skin is red in colour and is painful and pruritic lesions. After this it converts into blisters and oedema. It is also known as chill-blains.
2. Paradoxical undressing: It appears like homicide after sexual assault.
In hypothermia, if the thermoregulatory centre stopped, it causes skin vasodilation. And then the core blood shifts to cutaneous and the person feels warmth and undress.
3. Hide and Die Phenomenon: In this a person becomes disoriented, mental confusion is there and the person hides behind a bench, table, wardrobe, etc. and dies afterwards. That is why it looks like homicide after robbery.

Localized effect of cold

1. Trench foot

- It is also known as immersion foot.
- It is caused due to a moist cold.
- It occurs in soldiers, sellers, and people in the trenches.
- Mechanism: The area becomes red, cyanosis, pulsations are absent, necrosis and gangrene. This leads to formation of erythema
- It is seen at 5 to 8°C

If the hands are immersed in cold places, it is known as trench hands.



2. Frost nip-frostbite

- It is caused due to a dry cold.

Frostnip	Frostbite	
<ul style="list-style-type: none"> • It is the first effect produced by dry cold. • It has a nonfreezing effect. • It is a superficial injury. • It is non-permanent damage. • The mechanism is vasoconstriction. 	<ul style="list-style-type: none"> • It is the second effect produced by dry cold. • It has a freezing effect. • It can be superficial as well as deep injury. • It could be permanent damage. • A mechanism is a form of ice crystals (because frostbite is seen at a freezing temperature of -2.5° c, so that will cause freezing effect and there will be the formation of ice crystals and which will produce ischemia as well as gangrene) 	<ul style="list-style-type: none"> • There will be numbness, pallor, paller and burning sensation.
	<p>Superficial frostbite</p> <p>Numbness, Burning sensation Blisters with Clear fluid and itching may be present.</p>	<p>Deep frostbite</p> <p>Blisters with hemorrhagic fluid become black because of necrosis and gangrene.</p>
<ul style="list-style-type: none"> • The most common sites are the nose, ear, and face. 	<ul style="list-style-type: none"> • It is always an antemortal injury. 	

- Skin becomes hard and black in two weeks
- Treatment-rewarming is done at 42-44° C, protection from cold, and if there is an infection in the frostbite antibiotics and anti-tetanus treatment.

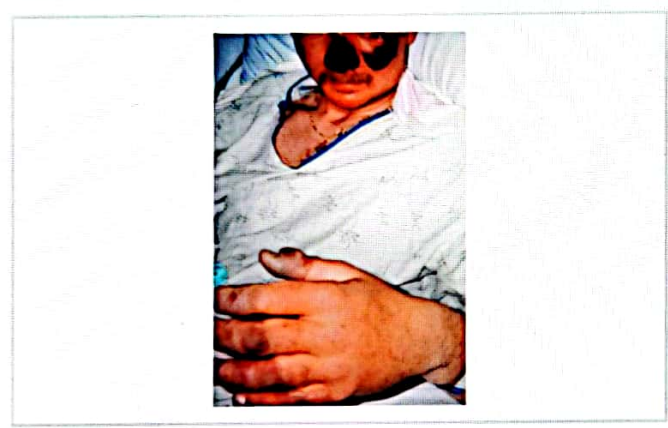

Heat Injury

Refer Table 13.1

- Most characteristic PM finding of heat stroke is edema/ reduction of purkinje fibre of cerebellum

Local heat injury

- Minimum Temperature
 - 44°C upto 5 to 6 hours
 - 65°C upto 45 Sec

Dry Heat Flame	Moist heat scald Liquid/ Steam
<ul style="list-style-type: none"> • Singeing of hair • Blackening blisters +/- 	<ul style="list-style-type: none"> • Splashing • Sodden and bleached • Line of redness present with vesicles • Charring, Singeing and ulceration. • Scalding can occur through clothes • Clothes worsen the damage

Scald and burn



- Scald is a liquid or stem over the body more than 60 °C
- If scald is a liquid or stem over the body more than 70 °C, it is called whole thickness scald.

Corrosive or chemical burn

- Ulcerated patches which are free from blisters.
- Hairs are not singed.
- Red line of demarcation absent
- Show distinct coloration

Cause	Dry heat	Moist Heat	Chemical
	Flame	Scald	Corrosive
Site	At and above contact	Below the site	Below the site
Splashing	Absent	Present	Present
Skin	Dry, wrinkled	Sodden, Bleached	Destroyed
Vesicles	At the circumference	Over the burnt area	Rare
Redline	Present	Present	Absent
Colour	Black	Bleached	Distinctive
Charring	Present	Absent	Present
Singeing	Present	Absent	Absent
Ulcer	Absent	Absent	Present
Scar	Thick, contracted	Thin, less contracted	Thick, contracted
Clothes	Burnt	Wet, non burnt	May be burnt

Classification of burn

Dupuytren's	Herbas	Wilson	Modern classification
<ul style="list-style-type: none"> • 1° • 2° • 3° • 4° • 5° • 6° 	<ul style="list-style-type: none"> • 1° • 2° • 3° 	<ul style="list-style-type: none"> • Epidermal • Dermo epidermal • Deep burn 	<ul style="list-style-type: none"> • Superficial burn • Deep burn

prince kumar
princeekum@gmail.com
992609733

1. Wilson

	Epidermal	Dermo epidermal	Deep
Erythema (redness)	Present	Present	Skin and tissue become white and yellow coloured or black charring of tissue forms eschar.
Pain	Present	Present	
Healing	Spontaneous and complete (takes 1 week)	If it involves the papillary dermis it takes 2 weeks. It is the reticular dermis, it takes 3 weeks.	
Scar	Absent	Present	
Blister	Absent	Present	

- Epidermal to dermo-epidermal, it is called superficial burn and from dermo-epidermal to deep burn, it is called deep burn.
- Dermoepermal burns are the most painful burns because nerves are exposed.
- Deeper burns are relatively painless because the nerves which transmit the pain become lost.
- Epidermal has dupuytren's 1st and 2nd°, dermo epidermal has dupuytren's 3rd and 4th°, deep burn has dupuytren's 5th and 6th°.
- Epidermal has herbas 1st°, dermo epidermal has herbas 2nd°, deep burn has herbas 3rd°.

Necklacing:

- It is a homicidal burn
- A method of homicide in South Africa.
- For killing, a tyre is used around and chest and an inflammable material.
- It is a burn Injury

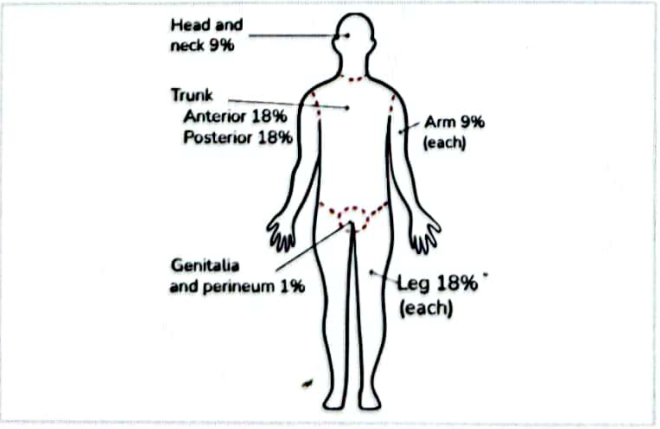

- For total body surface area, Rule of 9 also known as Wallace rule is used.
- 11 x 9 i.e., 99%.
- 1% is for genitalia and Perineal.

In adults,

- The head and neck is 9
- Upper limb is 9+9 (right and left)
- Chest is 9+9 (anterior and posterior)
- Abdomen is 9+9 (anterior and posterior)
- Lower limb is 9+9 for the right lower limb, and 9+9 for the left lower limb.
- In children's till infant age, modifications are there.
- The head and neck are big and are 18%.
- Lower limb is 13.5 for the right lower limb, and 13.5 for the left lower limb.

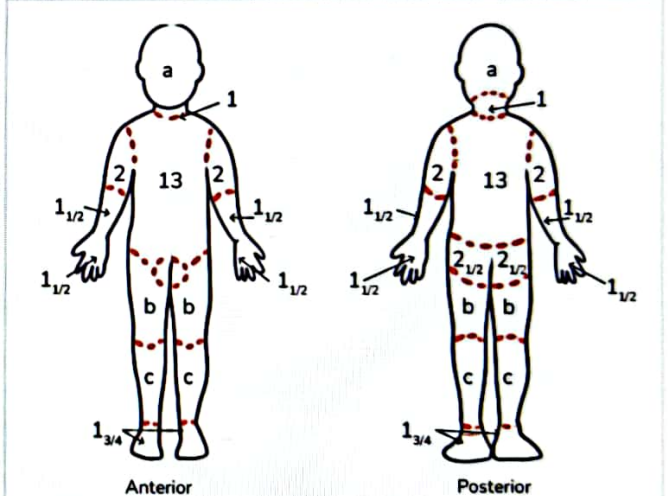

Relative percentage of body surface area (% BSA) affected by growth Age

Body Part	0 yr	1 yr	5 yr	10 yr	15 yr
a = 1/2 of head	9 1/2	8 1/2	6 1/2	5 1/2	4 1/2
b = 1/2 of 1 thigh	2 3/4	3 1/4	4	4 1/4	4 1/2
c = 1/2 of 1 lower leg	2 1/2	2 1/2	2 3/4	3	3 1/4

For children: Lund-browser's chart is used.

- 2, 1 1/2, 1 1/2 it is constant in every age (anterior and posterior)
- 13% for chest and abdomen

Body part	Age				
	0 yr	1-4 yr	5-9 yr	10-14 yr	15 yr onwards
a = 1/2 of head	9 1/2	8 1/2	6 1/2	5 1/2	4 1/2
b = 1/2 of 1 thigh	2 3/4	3 1/4	4	4 1/4	4 1/2
C = 1/2 of 1 lower leg	2 1/2	2 1/2	2 3/4	3	3 1/4

Rule of palm

- It is used for patchy burns .
- Palm covers 1 % body surface area this is called rule of palm

Park-land formula -

- Crystalloid (Ringer lactate) fluid is given .
- 4 ml/ kg IV fluid is given (half of the fluid is given in 1st 8 hrs and remaining half is given in the next 16 hrs ,total duration is 24 hrs)

Cause of death (MCC)-

- Immediate -Asphyxia ,carbon monoxide intoxication,neurogenic shock
- Early- within 48 hrs hypovolemic shock, In 3-4 days acute renal failure
- Late- 4-5 days septic shock
- Overall- septic shock
- Bacteria -pseudomonas

prince kumar
@princeekum@gmail.com
9928609733

PM finding -in burn cases

- Smell- kerosene/petroleum /chemicals
- Rigor mortis, livor mortis, Algor mortis -sometimes these are not appreciable
- Crowfeet sign -some area of the face will be spared from burn

	Antemortem	Post -mortem
Lines of redness	Present	Absent
Vital Reaction	Present (both positive or negative)	Absent
Enzymatic reaction	Present (both positive or negative)	Absent
Blister	Albumin protein +chloride	Air +thin fluid
CO-HB	Elevated Level (more than 10%)	Normal level
Cyanide	Increased level	Normal level
Carbon particle /soot particle	carbon particle in trachea (most characteristic)	Absent
Curling ulcer	Most common site is 1st part of duodenum	Absent

Non specific findings

01.04.28

- It can be found in antemortem and Postmortem and is caused by heat.

1. Pugilistic attitude

- It is also known as boxing attitude, fencing attitude, and heat stiffening.
- It is a contraction of muscles that causes a specific posture.
- It is seen when the temperature gets more than 65°C
- Above this temperature coagulation and denaturation of muscle protein occurs.
- It can be mistaken as the rigor mortis.

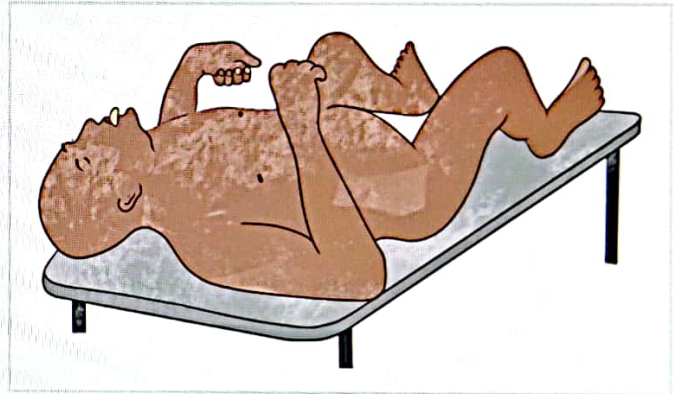

2. Heat Rupture

- It is mainly due to dehydration, coagulation of skin
- Skin and underlying tissues are ruptured.
- Extensor, fleshy, joint area is involved.
- Blood vessels and nerves are intact
- Bleeding, bruise, vital reactions are absent
- It can be mistaken as incised if it has a regular margin and it can be mistaken as lacerated if it has irregular margin.
- In incised and lacerated, the hair bulb will be crust and blood vessels and nerves will be crust and bleeding, bruise, vital reactions are absent.



3. Heat Hematoma

- It is seen in brain

- Mechanism- Dura contracted and blood excluded out from the venous sinus,
- It is above dura so it can be mistaken as an extradural or epidural hematoma.
- So to differentiate it -
 - It is chocolate brown in colour
 - It is showing a honeycomb appearance.

4. Heat fracture

- It is also known as thermal fracture and is seen in skull and long bones
- If it is seen in long bones it is street Avenue fracture.
- Mechanism: Dehydration or drying of the bones or skin. Because of this skull will burst and when the skull will burst this will be skull fracture.
- It can be mistaken as a traumatic fracture.
- This thermal fracture can cross the suture line but does not involve the suture line.

5. Puppet organs

- The internal organ of the body shrunken, firm, and fixed due to extreme heat.

prince kumar
princeeeekum@gmail.com
9928609733

Electrocution: (electric shock)

01:15:03

- It is mostly accidental and sometimes it can be homicidal or suicidal.
- Judicial electrocution seen in some states of the USA.
- Alternating current (AC) is more dangerous than direct current (DC) (4 to 5 times) because it causes tetanic contraction.
- The fatality of electrocution or the number of injuries of electrocution is directly proportional to the voltage and amperage. (Amperage is more important). Holding on spasm (tetanic spasm) will cause more injury.
- Resistance is inversely proportional to fatality or injury.

Cause of death

- Electrocution most commonly passes through the heart and causes ventricular fibrillation and cardiac arrhythmia.
- If it passes through the brain stem it will cause respiratory failure.
- If it passes through the diaphragm it will again cause muscle contraction and respiratory failure.
- Most resistant tissue is dry skin then bone and then moist skin.
- Electrocution has an entry and exit point, it claims to be the most dangerous circuit when the entry point is the right hand and exit point is the left foot.
- Point of contact is entry
- Point of grounding is exit

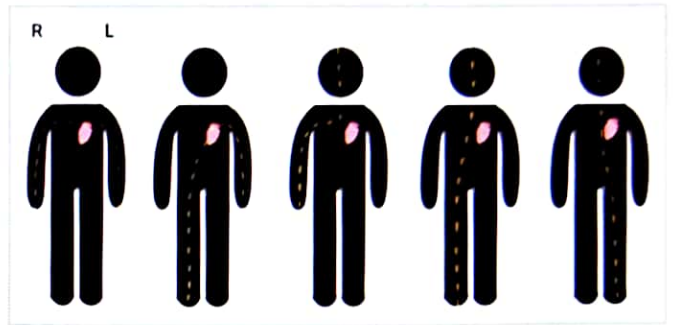

1. If the point of contact is the right side and the point of grounding is the left side, it affects the heart.
2. If the point of contact is the left side and the point of grounding is the right side it will also affect the heart.
3. If the point of contact is the upper part and the point of grounding is the right hand it will affect the brain stem.
4. If the point of contact is the upper part and the point of grounding is the right foot it will also affect the brain stem.
5. If the point of contact is the upper part and the point of grounding is the left foot it will affect the brain stem and the heart.

Postmortem finding

- Rigor mortis comes early
- Local haemorrhages and tears of muscles.
- Pit-like defects in the superficial surface of hair because of arching of current.
- Due to electrodes or wire the molten metal that is the current pearl goes deep into the soft tissue.
- Molten calcium phosphate from bone called bone pearls or wax drippings are detected in radiological investigations.
- When electricity goes in muscles it causes rhabdomyolysis and myoglobinuria.

Electric mark (Joule burn)

- It is seen in low voltage electrocution and with firm contact.
- It is an entry wound seen at the site of entry.
- It is known as joule burn. After touching wire, electricity goes inside the body and heat is produced in the body and because of the heat it is an endogenous burn.
- It can be of oval shape or round shape.
- It is like a crater, the central area is depressed or compressed and the peripheral area is raised, it is pale and areola.
- Mechanism is coagulation of dermis and elongation of epidermal cells.



Loose contact with air gap:

- It produces an exogenous burn known as flash burn or spark. (Patchy area)

Loose contact with high voltage:

- It is an arc dancing
- It produces multiple pitted/punched out burns known as crocodile flash burns. (Circulated area)

**Lightning injuries**

01:33:50



- It is an electric discharge from clouds.
- It is mainly direct current but is more dangerous because this direct current has high voltage.
- It is accidental

- It is known as keraunographic marking
- It is known as filigree burn.
- It is also known as arborescent marking and lichtenberg margin.
- It is a ferning pattern and is of pink colour.
- It has an erythematous and branching tree pattern (ferning).
- Its mechanism is denaturation of RBC which causes haemoglobin staining of the blood.
- It is seen upto 24 hours.
- The most common site is shoulder flings and abdomen folds.
- Difference from marbling:
 - Marbling is of green colour, and it is a vascular distension.
 - It corresponds to the vascular channels or vessels.

Spencer theory of lightning

1. Direct effect is because of high voltage
2. Superheated air of lightning produces burn
3. Expanded and compressed air.
4. Sledge-hammer effect: Air is compressed in front of lightning injury.

Lightning can hit directly, from side, indirectly.

Other injuries or effect from lightning

- Flame effect: burn on the body
- Blunt trauma: Heat Injury or other organ injury.



Table 13.1

Heat cramp	Heat exhaustion	Heat stroke
<p>It is also known as a miner's cramp or fireman's cramp</p>	<p>It is also known as heat syncope or heat prostration</p>	<p>It is also known as sunstroke or thermic fever or heat hyperpyrexia</p>
<p>If there will be excessive heat outside, there will be a loss of electrolytes (sodium and potassium) and water, Because of this there will be muscle cramps in the hands, legs, and abdomen.</p> <p><small>prince kumar princeeeekum@gmail.com 9928609733</small></p>	<p>In more heat sweating increases and there will be a loss of electrolytes and fluid (because of this there will be decreased venous return and it will cause decreased cerebral Perfusion)</p>	<p>It is common; if you are working in sunlight, if you have increased muscle activity, if you have some infection, and if you have a very humid temperature. If your body temperature goes above 104°F /40.5° C, in this case, your sweating will stop and you will get a heat stroke.</p>
<p>It is common in people working in miners and fire industries.</p>	<ul style="list-style-type: none"> • Clinical - Fainting, dizziness, and lightheadedness. • CBT-normal • Pupil -will be dilated • Skin -cold and moist • Cause of death is vascular collapse or syncope. 	<ul style="list-style-type: none"> • Mechanism -thermo regulatory center stopped and the hypothalamus stopped working. • Clinical -altered mental status, disorientation, loss of consciousness • CBT- is high (thermic fever) • Pupil -constricted • Skin -dry and hot skin • Sweating -stopped (anhidrosis).
<p>Treatment -fluids, and electrolytes are given.</p>	<p>Treatment -fluid therapy and elevation of the leg to increase the venous return.</p>	<p>Treatment -remove the clothes, bath with ice water, ice pack, and oral and IV fluid, and use AC and fan to decrease the temperature.</p>



CROSS WORD PUZZLES



Crossword Puzzle

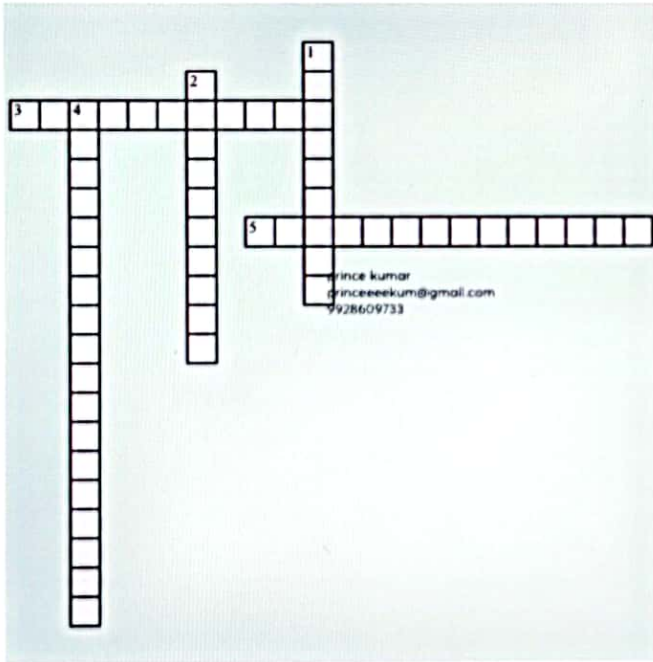

Across

- 3. when the temperature goes below 35°C.
- 5. known as heat syncope or heat prostration

Down

- 1. It is also known as miner's cramp or fire man's cramp.
- 2. It is a homicidal burn
- 4. It is also known as boxing attitude

14 REGIONAL INJURY



Head Injury

Skull fracture

- **Most common bone to be fractured- Temporal.** It has minimum thickness.
- Parietal - 5 to 10 mm thickness
- Occipital - 15 mm thickness
- Temporal - 4 mm thickness
- **Fissured fracture**
 - Also known as **linear fracture**
 - **Most common fracture of the skull**
 - It is seen in the autopsy.

Depressed fracture

- Caused by a heavy weapon or object.
- Striking surface of the weapon is small. E.g. Hammer.
- Small striking surfaces will cause depression.
- Pattern of fracture tells about the weapon.
- Also known as a **signature fracture** or **signature ala fracture**.
- Outer table is destroyed as well as the inner part is destroyed.

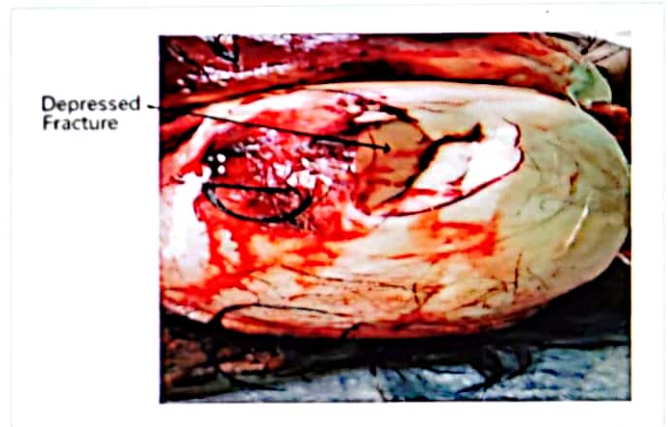
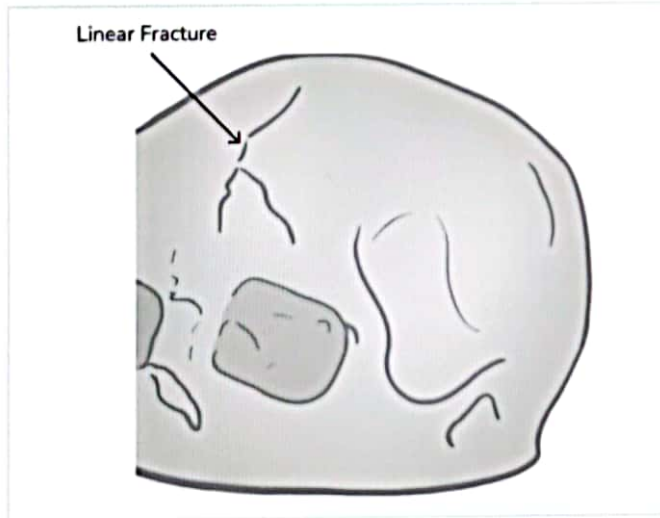

Pond or indented fracture

- Generally intact dura
- Inner table is intact.
- **Common in infant**
- Dent in skull bone is pond fracture.
- Also known as **ping pong ball fracture**
- Caused by obstetrics forceps blade.

Diastatic fracture

- Associated with sutural separation.
- Seen primarily in young adults.
- **Most common one is sagittal suture.**

Gutter Fracture

- Then is an oblique bullet and comes tangentially
- It is a fracture the in the outer table.
- This is known as a **glancing bullet**.
- Gutter formation in the outer table.

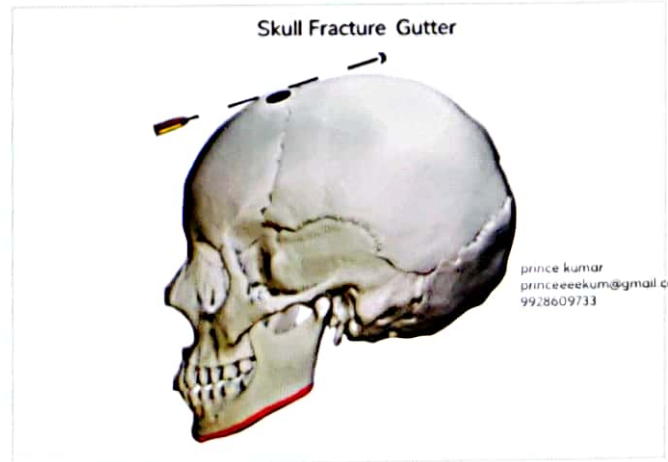
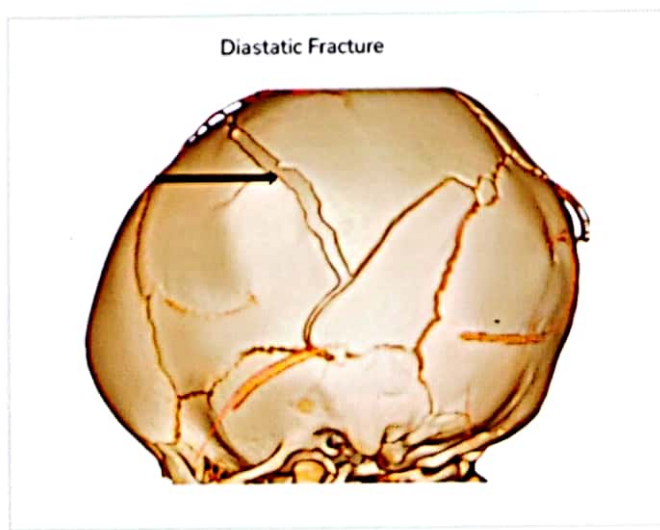

prince kumar
princeekum@gmail.com
9928609733

Comminuted Fracture

- o Heavy blunt blow
- o Multiple fragments are formed.
- o There are intersecting lines and webs, known as **spider web fracture**.
- o Fragments are displaced.

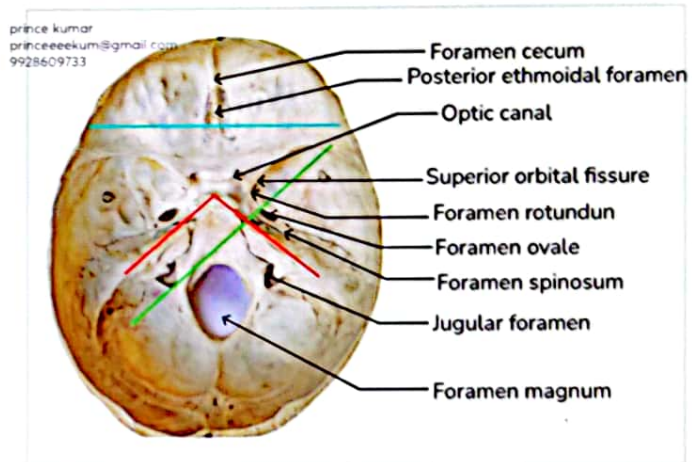
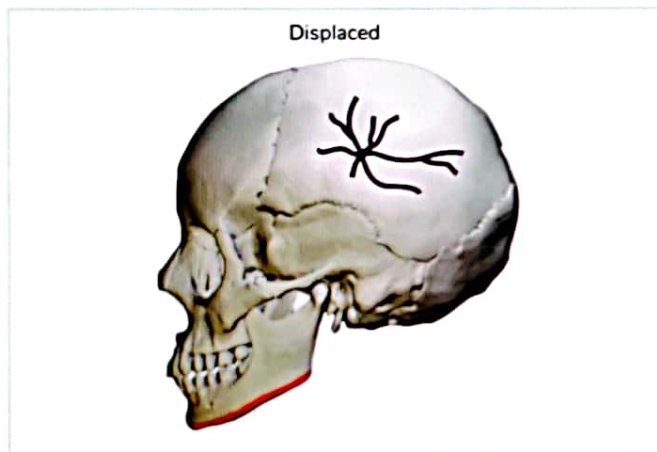

Ring or foramen fracture

- o Fracture surrounding foramen magnum.
- o Seen if someone falls from a height or falling on feet or falling on buttocks.
- o Can be due a to blow on the chin or blow the on vertex

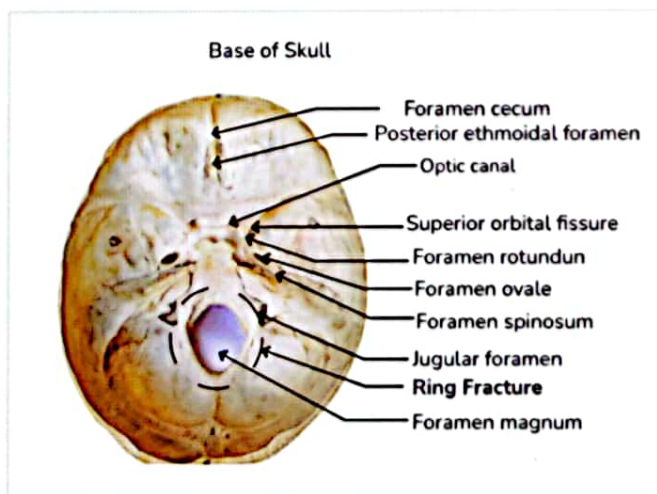

Motorcyclist Fracture

- o Common in people riding motorcycles.
- o **Fracture of the base of the skull.**
- o Force is on the skull that comes from one side to another, mostly in the temporal area.
- o Can classify in type 1, type 2, and type 3.
- o Type 1 a is hinge fracture. Petrus ridge to Sella turcica to contralateral Petrus ridge
- o Type 2 starts from the front area of one side and then to Sella turcica and then to the contralateral side.
- o Type 3 is a fracture in the anterior part.
- o **Type 1 can have a nodding face sign.**



- This is **posterior auricular ecchymosis or bruise**
- It is classified as an **ectopic bruise**.
- **Bow Out Fracture**
 - o This is caused by blunt trauma
 - o It is a fracture of the orbital wall
 - o It can be the medial, posterior, or floor of the orbital wall

Coup Injury	Countercoup injury
1. Coup is seen at the side of impact	Countercoup is seen on the opposite side of impact
2. Most common organ involved is brain, heart of lungs	Common is the brain.

Scenario's

1. If the coup is on the occipital region -The countercoup will be on the frontal region
2. If coup on the frontal region -The countercoup will not be on the occipital region
3. If coup injury on the temporal region on one side- The countercoup injury will be on the contralateral side (temporal)
4. If coup injury on temporal side- The countercoup injury on same hemisphere (ipsilateral) on contralateral surface
5. In mild or no coup injury- Severe countercoup injury can be there

- **Theory of coup**
 - Rotational shearing strain - Because of the mobile head, there is a shearing strain on the opposite side.

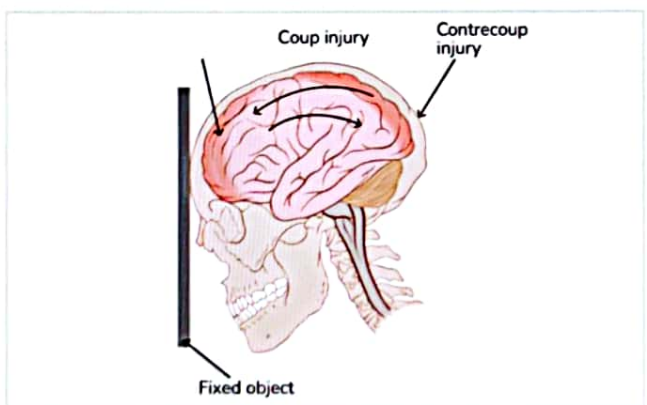

- Pressure gradient-When the head is mobile, the pressure gradient produces a vacuum on the opposite side of the brain. Because of the vacuum, there is stretching of the vessels which produces injury.
- Skull deformation or struck hoop theory-at the site of impact, there is compression.
- Compression goes inside. As a compensatory mechanism, there is bulging on the opposite side. This will produce contrecoup injury.

Intracranial hemorrhages

00:30:40

- First layer is the skull vault or cranial vault
- Then, we have dura mater Arachnoid mater, and Pia mater.
- Brain tissue/ Cerebrum
- The space between the skull and dura is almost none. There is an artery known as the middle meningeal artery.
- **Pterion** is a point where the frontal, parietal, sphenoid, and temporal meet.
- This space was epidural.
- The space between the arachnoid and dura is subdural space. We have bridging veins that drain to the Dural venous sinus and subarachnoid space.
- The space between the arachnoid and pia is subarachnoid. Here we have cerebro spinal fluid and many arteries of the circle of Willis.

Epidural Hemorrhage

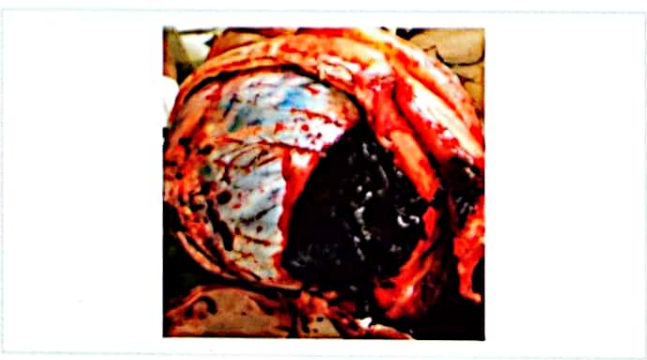

Also known as extradural hemorrhage

- In NC-CT EDH is a hyperdense area.
- It is a biconvex or lenticular shape.



- This is known as EDH.
- It is like an EDALY shape.
- EDH is exclusively by trauma.
- It is on the temporal site. The main part is pterion.
- EDH is not in the contrecoup region.
- Minimum amount is 100 ml which can cause compression of the brain and respiratory failure leading to death.
- Lucid interval is common here.

Lucid Interval

- Patient is unconscious and turns conscious and goes unconscious, which is known as a lucid interval.
- If you commit a crime, you will be responsible. In this lucid interval, you can act as a witness or write down a will.
- If the patient of head injury having EDH visits the doctor and the doctor does not do a medical examination or CT scan and lets the patient go. The patient then dies. So, the doctor doesn't perform the process. This is medical negligence.
- IPC is 304A. Punishment could be 2 years and fine.
- This is Epidural Hematoma
- Treatment
 - Aspiration
 - Burr and Hole
 - Craniotomy

EDH vs Heat hematoma

1. Caused by trauma	1. Caused by heat/burn
2. Always unilateral	2. It can be bilateral
3. Reddish color	3. Chocolate brown
4. Due to rupture of the middle meningeal artery	4. Contraction of dura mater. Due to the rupture of the Dural venous sinus, there is blood loss. Honeycomb appearance is seen.

Subdural hematoma



- It is sickle-shaped or banana-shaped.
- It is concavo-convex shaped.
- EDH on the brain side is convex.
- It is due to the rupture of bridging veins.
- This is below the dura.
- It is most commonly caused by trauma.
- About 100 to 150 ml is fatal.
- Even minor trauma can lead to this.
- Under what condition is this seen?
 - Non-traumatic reason is alcohol intake.
 - Widespread boxing injury
 - Common in children
 - Common in elderly people
- Sickle shape -concave-convex
- Shaking baby syndrome, which is part of a battered baby syndrome.
- It can be of 3 types.
 - Acute SDH - 0 to 3 days. Can be hyperdense.
 - Subacute SDH - 3 days to 3 weeks - can be iso-dense.
 - Chronic SDH - More than 3 weeks - can be hypodense.

How does SDH become chronic?

- Let's consider an old person who was having an injury, and it was a minor SDH.
- But he has not taken any treatment, then it becomes chronic after 3 weeks.
- This can cause cortical atrophy and other complications.
- **Subdural hygroma**
 - If CSF goes from subarachnoid space to subdural space, then it is called subdural hygroma.
- EDH vs. SDH
 - Towards the brain side EDH is convex.
 - Towards the brain side SDH is concavo-convex.
 - EDH is limited by suture lines but not SDH.

- Most common symptoms are mental confusion, drowsiness, dilation of the pupil, and contralateral involvement of hemiparesis.
- Treatment is decompression.

Subarachnoid (SAH)

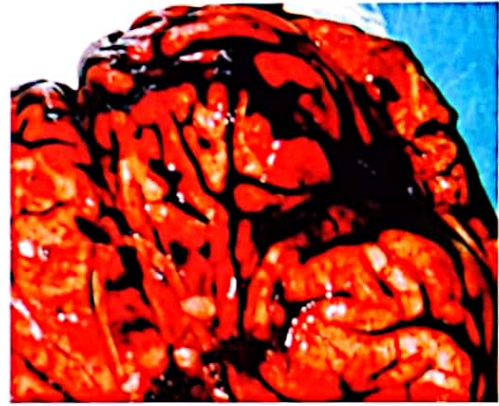

- It is below the arachnoid.
- SAH can be due to trauma/non-trauma but is **most commonly due to trauma**.
- Non-trauma is caused due to rupture of a berry aneurysm.
- Trauma is caused due to rupture of an artery of Willis.
- Most common symptom is a headache which is severe, excruciating pain. This is known as a **thunderclap headache**.
- Can lead to nausea and vomiting.
- Sudden loss of consciousness
- Neurological problems/photophobia
- Diagnosis:
 - In NCCT, the blood will be in the subarachnoid space.
 - Lumbar puncture can show blood in CSF.
 - This is known as **Xanthochromia**. It is seen in 4 to 6 hours. It is yellow in color due to bilirubin.
- For SAH, treatment will be endovascular coiling or clipping.
- To differentiate between SDH and SAH we will do a **water test**. Pour water. If the blood gets washed off, this is SDH. If the blood is not washed off, it is SAH.

Punch Drunk Syndrome

- It is also known as **Dementia Pugilistica**.
- It is common in boxing injuries.
- It becomes chronic SDH.
- Short-term memory loss is noticed.
- Disorientation to time, place, and person.
- Depression and mood change can be seen.
- Parkinson's symptoms-tremors, and stiffening of muscles can be seen.
- On autopsy-cerebral atrophy and neurofibrillary tangles can be seen.
- It is also known as **chronic traumatic encephalopathy**.

Telegram - @nextprepladdernotes

Intracerebral hemorrhage

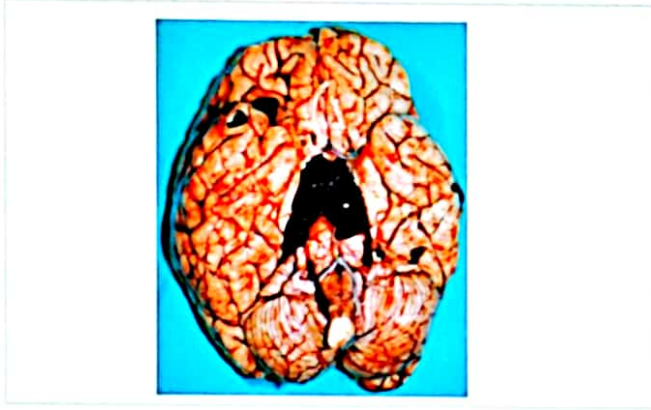

- It is due to a rupture of the middle cerebral artery.
- Most common cause is increased blood pressure.
- Most common site is the putamen.
- This is the **most common non-traumatic hemorrhage**.

- **Berlin's edema** is seen in concussion injury.
- **Comotio cerebri-s** - shearing stress in the brain leading to numerous small, punctate hemorrhages throughout the brain.
- **Diffuse axonal injury** - axonal bulb/retraction bulb (visible after 12 hours) - transacted axon
- **Duret hemorrhage** - hemorrhage of midbrain and pons.
- **Kernohan's notch** - result of raised intracranial pressure.

prince kumar
princeekum@gmail.com
9928609733



CROSS WORD PUZZLES



Crossword Puzzle

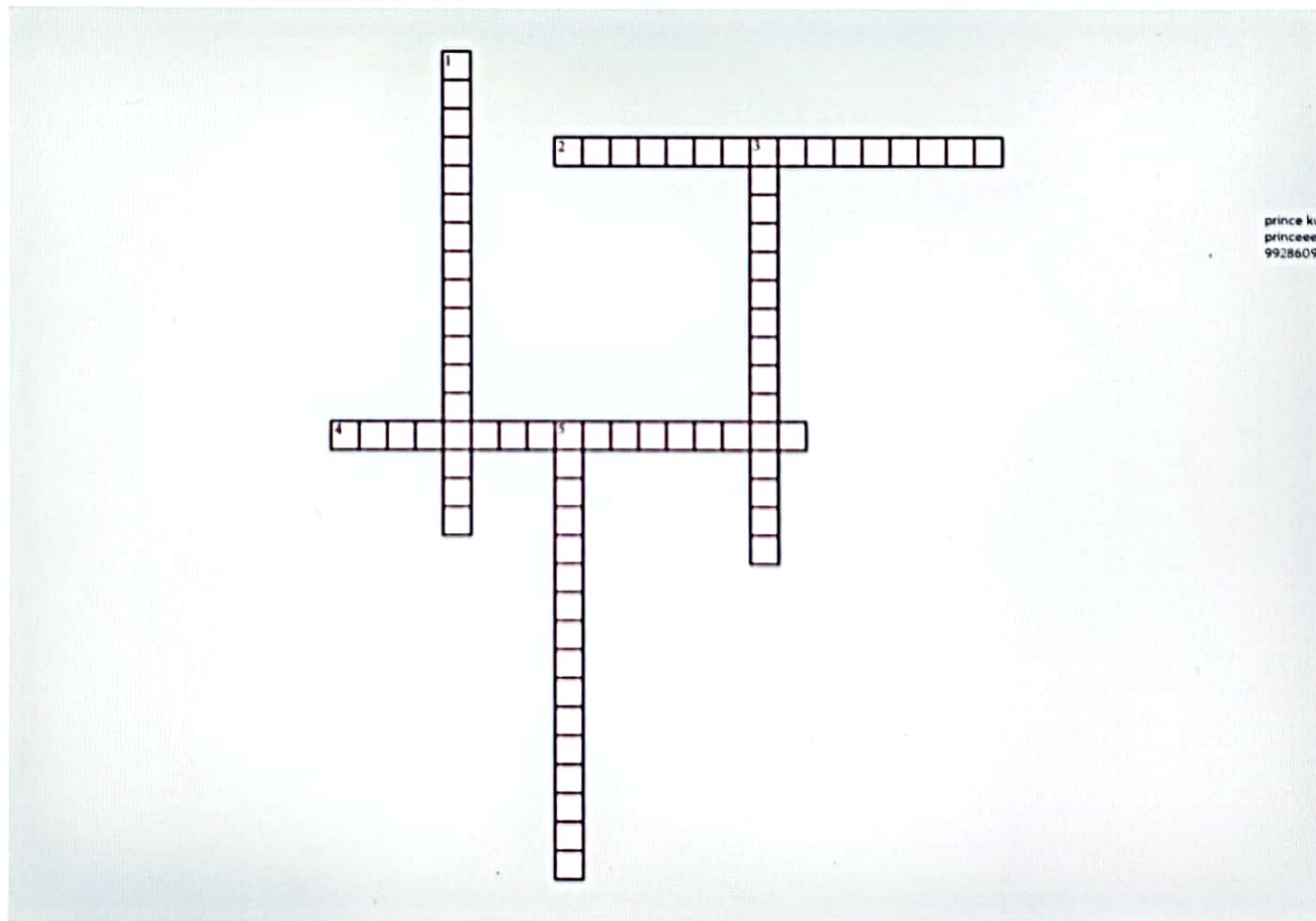

prince kumar
princeeeekum@gmail.com
9928609713

Across

- 2. Also known as linear fracture
- 4. Associated with sutural separation

Down

- 1. Caused by a heavy weapon or object
- 3. hemorrhage of midbrain and pons.
- 5. Berlin's edema

15 MECHANICAL INJURIES



- Injuries caused by
 - Mechanical pressure.
 - Mechanical trauma.
 - Mechanical friction.
- Injury under 44 IPC, any illegal harm to
 - Body
 - Mind
 - Reputation or property
- **Wound** is a breach of the natural continuity of either skin or mucous membrane.

prince kumar
princeeeekum@gmail.com
9928609733

Classification of Mechanical Injuries

00:09:05

- Due to blunt force (stone, hammer, or heavy objects)
 - Abrasion
 - Contusion
 - Laceration
 - Fractures or dislocations
- Due to sharp force (knife, blade, sword, ax)
 - Incision
 - Stab (pointed objects)
 - Chop (axe) may also fall under laceration.

A. Due to Blunt Force (Stone, Hammer or Heavy Objects)

a. Abrasion

- Most **common** mechanical injury.
- **High** medico-legal importance.
- Loss of epidermis (**scrapping** of epithelium)

Recall

319 IPC section - that comes under simple hurt

- Abrasion is a simple injury.
- No active bleeding
- No scar

Golden Points

- Corneal abrasion causes corneal opacity (visual restriction)
- Under 320 IPC it is a Grievous hurt

Abrasion force

- **Tangential force**, along the epidermal layer
 - Scratch abrasion
 - Grazed abrasion
- **Perpendicular force**, perpendicular to the epidermal layer
 - Pressure abrasion
 - Imprint abrasion

Scratch Abrasion



- **Scratch abrasion**
 - It is a line
 - Also known as **Linear abrasion**.
 - It is by tangential force.
 - Length is **good**.
 - Width **not significant**.
 - **Examples**
 - Fingernail abrasion
 - Thorne abrasion
 - Pin abrasion
- **Grazed abrasion**
 - It is by **sliding** on rough surfaces (roads)
 - Most **common** road traffic accidents
 - **Also known as**
 - Grinding abrasion
 - Grave rash
 - Brush-burn
 - Sliding abrasion



- **Pressure or Crushing abrasion.**
 - Continuous pressure causes the **crushing of the epidermis.**
 - Force is perpendicular (90°) to the epidermis.
 - There may be **chances of Contusion** also.
 - **Examples**
 - Ligature mark (hanging and strangulation)
 - Bite mark



- **Imprint abrasion**
 - Also known as
 - Impact abrasion
 - Contact abrasion.
 - Patterned abrasion.
 - **Forms pattern** of object or weapon
 - Perpendicular force but is caused by a rough object with an **irregular surface.**
 - **Examples**
 - Tyre marks
 - Patterned Ligature mark.

Golden point: In most cases, ligature marks are pressure abrasions



The direction of the force

- **End of abrasion** have
 - **Multiple lines**
 - Uneven lines
 - Longitudinal lines
 - Lines are heaped up or aggregated.
 - Also known as Epithelial tag
- **Direction** of abrasions is identified by endpoints easily.

Duration of abrasion

- **Age of abrasion** can be identified by the color the of scab.
- Scab is a **dry blood or lymph exudates** after an abrasion.
- Color of scab
 - Bright red scab: 12-24 hours (>12 hours)
 - Reddish brown scab: 2-3 days
 - Brown scab: 4-5 days
 - Black scab: 6-7 days
- Before 12 hours **no scab** is seen.
- After 7 days the scab **falls.**
- Abrasion gives an idea for **suspected crime/manner of death.**
- Example,
 - Throttling: Crescentic fingernail abrasion.
 - Sexual assault: Genital abrasion.
 - Smothering: Perioral abrasion.
 - Tyre mark

Differential Diagnosis of abrasions

- Ant erosion
- Excoriation surrounding the anal canal.
- Pressure sore
- Dry skin
- Postmortem Abrasion

Postmortem Abrasion vs Antemortem abrasion

Feature	Postmortem abrasion	Antemortem abrasion
Intra-vital reaction or congestion	Present	Absent
Site	Any site	Bony prominences
Color of abrasion	Yellowish white	Color changes
Scab	Less raised	Raised
Exudates	Less	High

b. Contusion

- Also known as **Bruise**
- Injury to the **dermis**
- Dermal blood vessels are **ruptured** which clots blood.
- Due to this **extravasation**, swelling or raised area is seen.
- Force caused by **blunt objects.**
- Contusion has extravasation or swelling known as a bruise.
- Margins are **irregular.**
- **Stomping** (kicking and jumping) is seen.



- Color changes
- **Hematoma** is seen by dissection of the skin.

Factors

- **Site**
 - **Vascular and loose area**
 - face, vulva, eyelid, and scrotum
 - Impact, force, trauma smaller
 - Size of the contusion is bigger.
 - **Bony prominences**
 - Impact, force, trauma smaller
 - Size of the contusion is bigger.
 - **Thick skin**
 - Palm and sole or abdomen
 - Impact is bigger.
 - Size of the contusion is smaller.
- **Age**
 - **Children and old persons**
 - Size is bigger.
 - Delicate skin or subcutaneous tissue
 - Relaxed skin
- **Sex**
 - Females have more **relaxed or delicate skin** or subcutaneous tissue
 - Size of the contusion is **bigger**.
- **Complexion**
 - **In whites**
 - Bruise is seen easily.
 - Color changes easily.

Age of Bruise

- Blunt object moves the blood to the **periphery**.
- Color changes of the bruise starts from the **periphery to the center**.
- **Colors**
 - Red, fresh color of contusion (1-2 hours)
 - Violet+Indigo: Blue (Deoxygemoglobin, few hours-3 days)
 - Brown (Hemosiderin, 4th day)
 - Green (Biliverdin, 5-6 days)
 - Yellow (Bilirubin, 7-13 days)
 - Original color, seen after 2 weeks.
- No color changes due to **Oxyhemoglobin**
 - Subconjunctival hemorrhage (oxygen supply is provided).
 - Meningeal hemorrhage (oxygen supply is provided).

Feature	Bruise	Hypostasis (Postmortem staining)
Site	Any site with trauma	Dependent parts of the body
Cause	Trauma	Postmortem changes
Color change	Present	Absent, generally bluish white
Margins	Irregular	Regular
Extravasation	Present	Absent
Blanching	Absent	Present
Incision test	Not washed away	Washed away

Golden Points

- **Blanching:** Become colorless when pressure is applied.
- **Incision test,** pour water into the incision on the skin.
 - Bruise has clotted blood, it is not washed away.
 - Hypostasis has blood in blood vessels, it is washed away.

Ectopic Bruise

- Also known as **Migratory Bruise**
- Trauma is at a different site, and the bruise is at a different site.
- **Example:** In an Anterior cranial fossa fracture bruise is periorbital or periorcular



prince kumar
princeekum@gmail.com
9928609733

- Causes **Raccoon sign** or **Black eye** or **spectacle hemorrhage**.
- In a Middle cranial fossa fracture bruise is at the mastoid tip or posterior auricular area.



Battle Sign

- Causes **Battle sign**.

Patterned Bruise

- Forms **object pattern**
- Lathi/rod/stick forms Tramline/Rail line bruise
- Pinching forms a **Butterfly bruise**.

Recall: Battered Baby Syndrome (BBS) forms Butterfly bruises and six-penny bruise.

- Throttling with finger-tip pulp forms **Coin shaped bruise (Six penny bruise)**

**Artificial Bruise**

- **Criminals** may produce bruises artificially.
- By harming **themselves**.
- Products used to harm.
 - Plumbago
 - Semicarpus Anacardium (Marking nut)
 - Madar/ Calotropis

Differential Diagnosis of Artificial Bruise

- **Site:** Accessible parts
- **Margin:** Regular or well-defined.
- **Shape:** may be irregular
- **Content:** Acrid serum, redness, inflammation
- Blister with itching
- Chemical test positive for a chemical present in the object used.

Come-out Bruise

- **Other names**
 - Delayed bruise
 - Percolated bruise
- Extravasation in deep tissues **comes out within 1-2 days**.
- Even **after death** delayed bruising is seen.
- **Infrared photography** is used to diagnose a delayed bruise

Golden Points

- Bruise/contusion is not medicolegally significant.
- Size is not well defined.
- Delayed bruise may be seen.
- Color maybe not be confirmed always.
- Age of the bruise is not clear
- In Ectopic bruises, trauma, and bruises are at different sites

c. Laceration

- Also known as **Tear**
- **Trauma:** **Blunt** trauma, may be **heavy**
- **Damage:** 3-Dimensional injury
 - Length
 - Width
 - Depth
- **Margins:** **irregular**
- **Floor:** vessels, nerve, and hair bulb are **crushed**.
- **Structures:** Epidermis + dermis + subcutaneous tissue.
- Swallow tail, tearing at the end, **diverging**.
- **Tissue bridges** and tissue fragments connect each other from the margin.
- Bleeding comparatively **less** due to crushed blood vessels.

Golden point: Bleeding is more in incision

Types of Laceration**1. Split Laceration**

- Also known as **Incised looking laceration**.
- Seen on the **hard surface** of the body.
 - Skin is attached to the bone.
 - Less subcutaneous tissue
 - **Example**
 - Scalp
 - Forehead
 - Eyebrow
 - Chin
 - Zygoma
 - Shin (Pretibial region)
 - Iliac crest
 - Perineum
 - Posterior part of the elbow
- **Margin:** Clean cut, regular when observed with **naked eyes**.

prince kumar
princeeeekum@gmail.com
99286097111



Note: Don't ever examine injury with the naked eyes

• **Magnifying lens:** (differentiate from an incision)

- Crushed tissue and **Crushed hair bulb**
- Bleeding is less.
- Tissue bridges

2. Avulsion

- Also known as **Shearing laceration**
- It is a kind of **separation** when a lorry wheel run over a limb in run-over injuries).
- Detach of tissue: **Acute angle**
- 2 Categories are seen.
 - **Flaying**
 - Large area is detached.
 - But one point is connected to the surface (skin or subcutaneous tissue)
 - **Degloving**
 - Skin or subcutaneous tissue comes out from the limb.
 - Like a glove



3. Stretch Laceration

- **Force:** Tangential force
- Due to overstretching of the skin or subcutaneous tissue which is **fixed**.
- Forms a **Flap (tearing)**
- **Commonly** seen in compound fracture, a bony fragment comes out.
- A motor vehicle running over.
- Kicking with the boot forms a flap (tearing)

4. Cut Laceration

- Cut is caused by a **sharp weapon**.
- Laceration is caused by **blunt weapons**.
- **Weapon:** Sharp-ended, heavy
 - Axe
 - Hatchet
 - Chopper
- It is a **cross** between an incision and a laceration.
- Edges of weapon: sharp, heavy.
- Cut the skin and tissue.
- **Margin:** crushed (heavy weapon), bruised (contusion).
- Crushed tissue and hair bulb seen.

Golden point: Tissues are cut and crushed

- Underlying bones are **fractured**.
- Gaping is more, known as **Chop wound**.



Chop wound with an axe.

- Heel (lower) end strikes first.
 - Depth of the wound is more.
- Toe end strikes first.
 - Depth of the wound is less.
- **Direction and force** of the weapon can be determined.
- Gaping is **more**.
- These can be always **homicide** in nature.

5. Tear

- Most **common** type of laceration
- By any **irregular hard surface**
 - Door handle of the car
- It can be on the **skin or viscous**.

B. Due to Sharp Force (Knife, Blade, Sword, Axe)

a. Incision

- Also known as **Cut injury**.
- **Weapon:** Sharp edged, parallel to skin surface.
 - Knife
 - Blade
- Maximum dimension: **length > breadth > depth**.
- **Margin:** Clean cut, regular by the naked eye.
- Magnifying lens used to see structures cut not crushed.
 - Vessels
 - Nerves
 - Hair bulb
- Hemorrhage/ bleeding is **profuse**.

Recall: Split laceration looks like an incision.

- Laceration-looking incised wounds in loose skin or tissue area.
 - Axilla
 - Scrotum
- When a sharp object is applied, these loose surfaces produce **irregular margins**.
- Without a magnifying lens, it **looks like a laceration**.

Phenomenon involved in an Incised wounds.

1. Tailing

- Important phenomenon
- Deep at the beginning, shallow (superficial) the at end
- **Importance:** direction of the weapon

2. Beveling

- **Obliquely strike.**
- **Undermined edges** are known as beveling.
- **Importance:** position of assailant and victim
- **Common in genitalia** (homicide)
- **Medicolegally significant**

Incised Wound (with Tailing)



Age of Incised Wound

- **Fresh:** Hematoma
- **12 hours:** Edges-red, swollen.
- **24 hours**
 - Endothelial cells cover edges and margins and forms scabs.
 - Vascular bud begins.
- **36 hours:** Capillary network completed.
- **48-72 hours**
 - Fibroblasts are seen in the wounds.
 - Capillary bud comes inside.
- **3-5 days**
 - Fibrils are seen.
 - Collagen fibers are seen.
 - Vessels are thickened and obliterated.
- **1-2 weeks:** Formation of scar

Self-Inflicted Suicidal Wound

- Found in **inaccessible parts.**
 - Forearm (wrist)
 - Neck
 - Abdomen
- **Suicidal** in nature
- Multiple, uniform in size and depth.
- **Parallel lines**
- Mostly **superficial** wounds.
- Deep wounds cause **death.**
- Also known as

prince kumar
princeeeekum@gmail.com
9928609733

- Hesitational cut.
- Trail cut.
- Tentative cut
- Mainly **incised wounds.**

Self Inflicted Incised Wound



b. Stab Wound

- **Weapon:** Sharp-edged, pointed.
 - Knife
 - Sword
- **Perpendicular** to the epidermal layer.
- **Maximum dimension:** Depth
- **3 types**
 - **Puncture:** Stab on tissue or skin
 - **Penetrating:** Thoracic or abdominal cavities
 - Most common Liver damage is seen.
 - Only entry wound is seen.
 - No exit wound.
 - Withdrawal may cause taling (superficial damage to less depth side)
 - **Perforating:** Through and through
 - Entry and exit wounds are seen.
 - Entry wound is large with inverted margin.
 - Exit wound is small with everted margin.

Knife

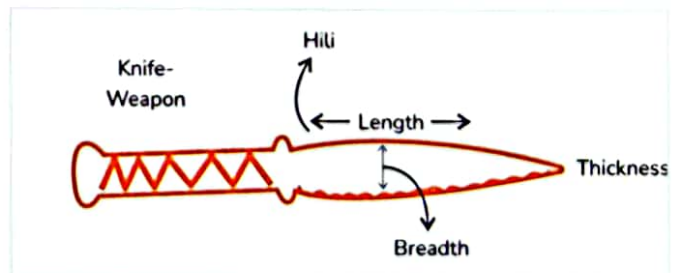

- **Parts**
 - Handle
 - Hilt
 - Blade (metallic part)

- Dimensions of knife
 - Length
 - Breadth
 - Thickness
- If the knife enters the body, the **maximum dimension is depth.**
- **Depth of injury is approximately equal to the length of the weapon.**
- **Length of the injury is slightly lesser than the breadth of the weapon.**
- This is due to **skin stretching.**
- **Thickness of the weapon is equal to the breadth or width of the injury.**

The shape of the Stab injury

Feature	Single edged weapon	Double edged weapon
Sharpness	One side sharp, one side blunt	Both sides sharp
Shape of injury	Triangle/wedge Tear drop. Fishtailing	Spindle Oval

Golden Points

- In Fish-Tailing, formation of the tail due to the splitting of the skin
- This splitting is by a blunt edge

Stab (Puncture Wound)

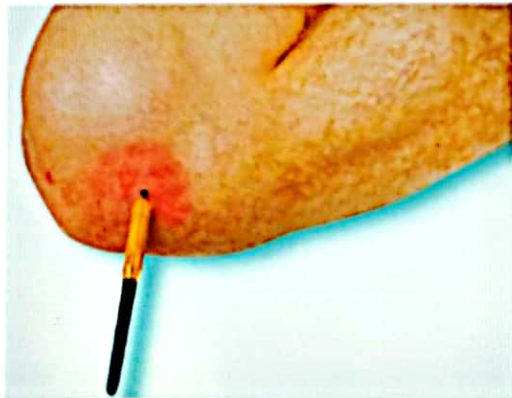

Golden points

- If **Hilt** is present in the weapon and completely penetrates the body, it causes damage.
- **Other name**
 - Hilt abrasion
 - Hilt contusion
 - Hilt laceration

Lines of Langer-Gaping

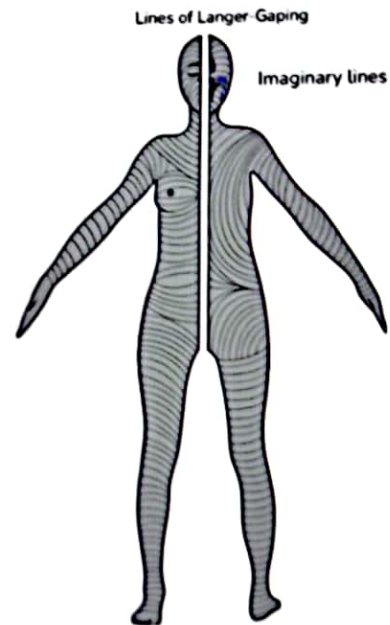

- **Imaginary lines**
- Corresponding to **collagen fibers** of the body
- Gives an idea about the **gaping** of the body.
 - If stab injury is parallel to these lines, then gaping would be less.
 - If stab injury is perpendicular to these lines, then gaping would be more.
- Collagen fibers are cut in **perpendicular injury.**
- Collagen fibers are not cut in **parallel injury.**
- Lines of Langer gives **shape and size of the injury.**

Hara-kiri

- Also known as **Seppuku**
- Common in **Japan**
- It is a **stab injury.**
- Sword or long-handled knife is used to commit **suicide.**
- Sword is **hit in the abdomen.**
- Intra-abdominal pressure (**IAP**) becomes very low.
- **Evisceration** (viscera comes out)
- Leads to **cardiac collapse.**
- **Syncope/hypotension** is seen.

Concealed puncture wounds

- Concealed parts of the body
 - Nostrils
 - Fontanelle
 - Axilla
 - Vagina
 - Rectum/anal canal
 - Inner canthus of the eye
 - Nape of the neck (pithing)

Recall: Stomping (kicking and jumping) on the body is seen in Contusion

- **Gross examination or Meticulous postmortem examination is to be done.**

Defense wounds

01:48:00

- Caused during **defending**.
- 2 types
- 1. **Active**
 - Most common site is the **Palmar** surface.
 - Grasp
 - 1st web space
- 2. **Passive**
 - Most common site is.
 - **Medial or ulnar** aspect of the forearm
 - Extensor aspect of forearm or wrist
- **Medicolegal importance: Homicide**

Golden Points

- Defense wounds are not seen.
 - Back
 - Unconsciousness

Fabricated Wounds

- **Self-inflicted**
 - Self-harm to the body.
- **Self-suffered**
 - Taking the help of others to hit your body.
 - Very potential

Differential Diagnosis of Fabricated wounds

- **Motive** is present.
- **Discrepancy** between injuries in the body and history given.
- Defense wound is **absent**.
- **Accessible parts** of the body
- **Cloths** not involved.

Overkilling

- **Massive, Multiple injuries** on the body
- Due to **anger, rage**
- Injury required **more** than causing death.
- **Example:** Stabbing 15 times, in which stabbing less than 15 times is enough to cause death.



PREVIOUS YEAR QUESTIONS



Q. Rupture of the skin and subcutaneous tissue is prince kumar
princeeeekum@gmail.com
9928609733
(FMGE May 2018)

- A. Incised wound
- B. Abrasion
- C. **Lacerated wound**
- D. Contusion

Q. A dead body with a wound on the neck with clean cut edges, crushed tissues with disrupted vertebra body portions. Identify the type of the wound? (FMGE Aug 2020)

- A. Cut wound
- B. **Chop wound**
- C. Laceration
- D. Avulsion



CROSS WORD PUZZLES



Crossword Puzzle

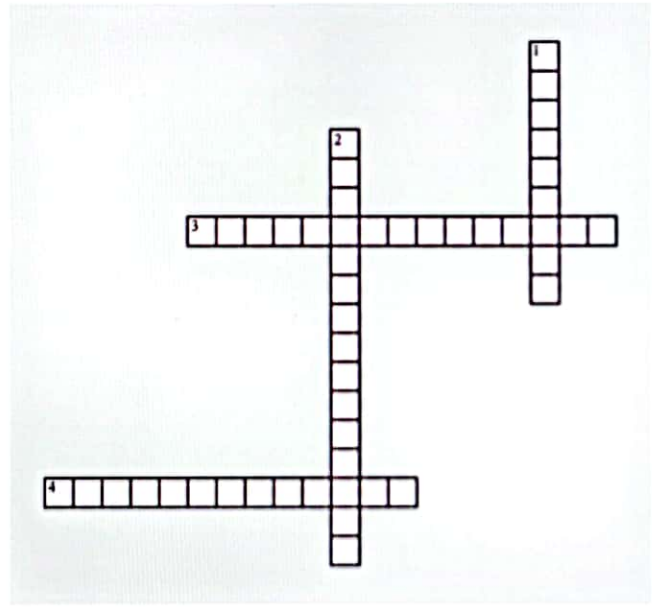

Across

- 3. Tyre marks
- 4. Migratory Bruise

Down

- 1. Injury to dermis
- 2. abrasion is a Grievous abrasion

prince kumar
 princeeekum@gmail.com
 9928609731

16

FORENSIC BALLISTICS



Firearm(ballistics)

- **Father of ballistics- Calvin Goddard**
- **Projectile motion:** Ballistics is a study of projectile motion. Anything which comes out from firearms. Examples- Bullets, lead shot.
- Firearm- weapon
- Ammunition- bullet, explosive material
- Problem- wound.
- All these three things are called **forensic ballistics**.

Classification of Ballistics:

00:01:51

- **Proximal (internal) Ballistic:** Study of the projectile in firearm weapon.

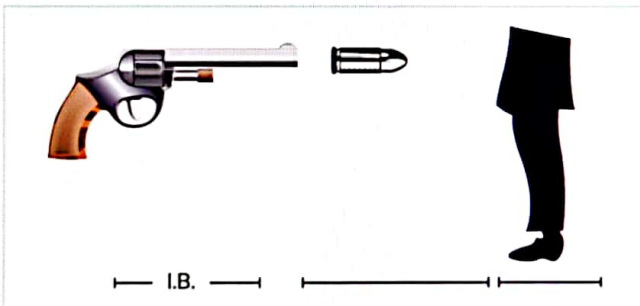

- **Intermediate(exterior) Ballistic:** Study of the motion of projectile gun barrel till the time it hits the target.

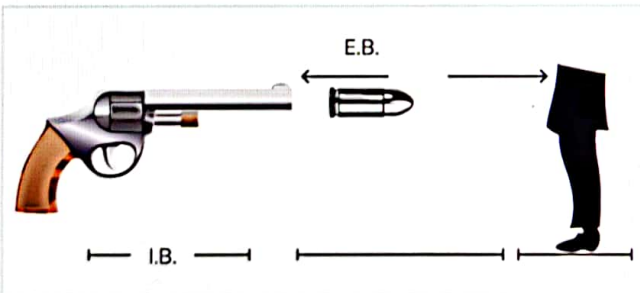

- **Terminal Ballistics:** Penetrate the target.
- **Wound Ballistic:** Penetrate in living tissue.

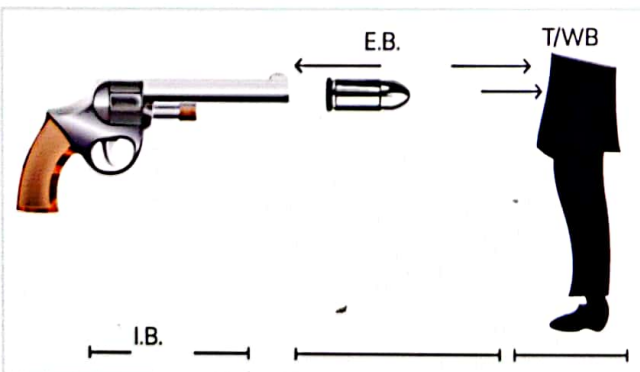

Classification of Firearm:

00:03:47

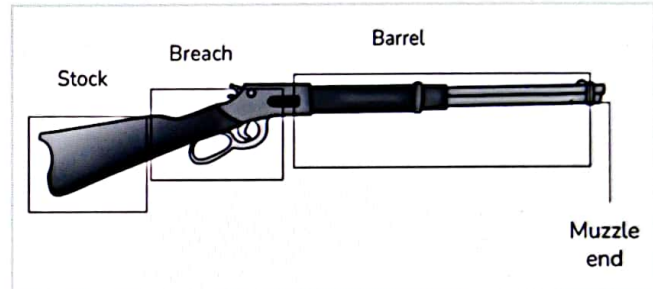

Rifled arm	Smooth bore firearm
<ul style="list-style-type: none"> • Condition of barrel: There is elevation and depression present. Elevations are known as lands, and depressions are known as grooves. • Caliber: Distance between two opposite lands. • The projectile in the cartridge: Bullets • Range: High 	<ul style="list-style-type: none"> • Condition of barrel: Inside surface is smooth in smooth bore firearm. • Caliber: Bore • The projectile in the cartridge: Pellets/ lead shot • Range: Low

Advantages of Rifling in Rifled firearms:

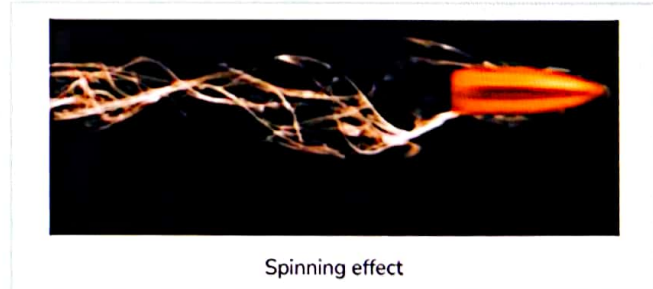

Spinning effect

- It has spin and rotation of the bullets.
- Increases accuracy and range (kinetic energy is more therefore range is more).
- It checks wobbling effect.
- It causes gyroscopic stability.
- Enhances wounding power.
- **Caliber or Gauge:** it is used for rifled weapons.
- **Bore or Gauge:** it is used for smooth bore weapons.
- The number of balls/pellets of equal size/weight are made up of **1 pound lead(454gm)**
- 12 bore = 12 balls
- Bore decides the size of the pellets

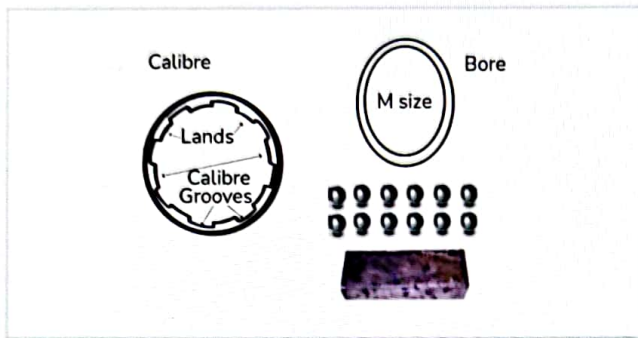

Helixometer: It is an instrument to examine the inner surface of a barrel.

How to increase the range of Shot-Gun

Different ranges of Firearm:

- Shotgun: 50 to 60 yards
- Revolver: 200 yards
- Pistol: 400 yards
- Military Rifle: 1000 to 3000 yards
- Airgun: 40 yards. The mechanism is air compression. Absence of tattooing, blackening, and singeing.

Paradox gun: It is a mixed gun. It has features of both rifle and shotgun. It is a shotgun in which a part of the barrel towards the muzzle is rifled.

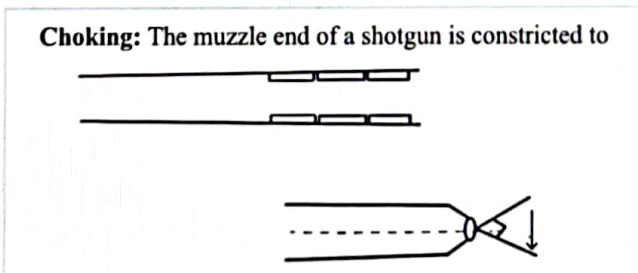

Choking: The muzzle end of a shotgun is constricted to

- Lessen the rate of speed of the shot.
- Increase the velocity of pellets.

Different types of choking:

- Unchoked or cylindrical base: its range is 25 yards.
- Improved cylindrical choke: its range is 30 yards.
- Modified cylindrical choke: its range is 35 yards.
- Full choke: its range is 40 yards.

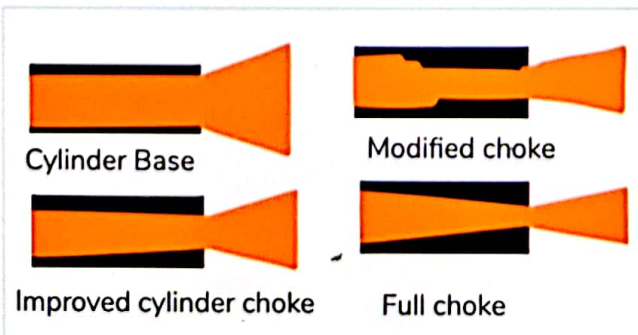

Cartridge: Loaded within the firearm

- Primer: which ignites
- Propellant: Gunpowder
- Projectile: In rifle, it is bullets, and in the smooth bore, it is pellets.

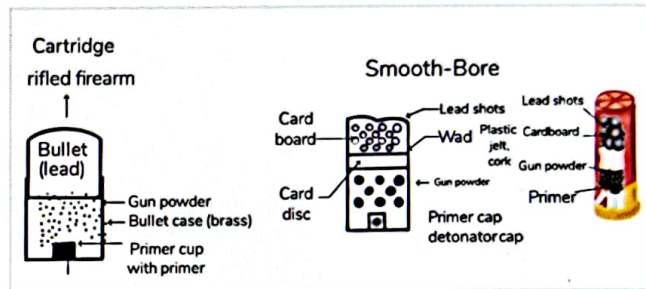

The Rifle cartridge:

- On the base, we have a primer cup.
- In a rifled firearm, we have a bullet case composed of Brass (copper + Zinc)
- A bullet made of lead.

Cartridge of Smooth Bore Firearm:

- Primer cap/detonator cap/percussion cap
- Gun powder
- Cardboard disc as known as Wad.
- Lead shots.

Wad Function:

- It separates projectiles from propellants.
- It seals air.
- It acts like a piston and lubricant.

Lead Shot: it is pellet/ lead balls.

- Soft: composed of lead
- Hard: composed of Lead and Antimony
- Steel: composed of steel

Size: It varies from Dust shot, Birdshot, and Buckshot.

Primer Composition:

- B- Barium Nitrate
- L- Lead peroxide
- A- Antimony
- S- Styphnate/ Antimony Sulphide
- T- Tetrazine

The function of Primer:

- 1st it burns then detonates(explodes) and then ignites the gunpowder.

Gun Powder: it is of 3 types.

1. Black (POCSO)
- PO: Potassium Nitrate (75%)

- C: Charcoal (15%)
- SO: Sulphur (10%)
- 1 gm produce 3000-4000 cc of gas.
- Produce more smoke.
- Have less power.

2. Smokeless

- Single base: it contains Nitrocellulose.
- Double base: it contains Nitrocellulose and Nitro-glycerine
- Triple base: it contains Nitrocellulose and Nitro-glycerine, Nitroguanidine
- 1 gm produces 12000-13000 cc of gas.
- Produce less smoke.
- Have high power.

3. Semi Smokeless Gunpowder contains 80% Black and 20% Smokeless gunpowder.

- Designated as FG, FFG, FFFG, etc. in gunpowder are known as
- FG: fineness of gunpowder. When the number of F increases, there will be an increase in the fineness of gunpowder and an increase in power.

Gunshot Residue Test (GSR): Composed of primer and lead.

- H-Harrison and Gillroy test. It can detect Antimony, Barium, and Lead.
- A- Atomic absorption Spectrometry. It can detect Antimony, Barium, Copper, and Lead
- N- Neutron activation analysis.
- D- Dermal nitrate test, also known as Paraffin test.
- S- Scanning electron microscopy energy dispersive X-ray analysis (SEM-EDXA). It is the most specific test.

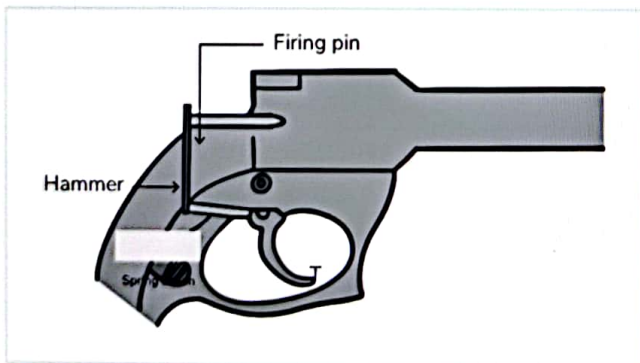

The sequence in Firing:

- Pull the trigger. Once you pull the trigger, the hammer will rise. It will move upwards and release, hitting the firing pin, and then it will move forward. So, the primer burns. Then the primer burns, and flames produce gunpowder. When gunpowder ignites, gas or smoke in a small compartment is produced, and the projectile can out.

Bullets:

- Damage depends on the velocity.
- Large round bullets have greater damage.
- Should be picked by hand from the crime scene.

Types of bullets:

00:41:59

- Souvenir bullet: also known as sleeping bullet. It is a retained bullet in the body or skin. Surrounding the bullet there will be fibrosis; it is composed of lead. So, it will cause lead poisoning, which is known as Plumbism.
- Frangible: It divides into multiple components. Composed of Iron and copper.
- Tumbling: Rotates end-to-end.
- Duplex: Two bullets in a cartridge.
- Tracer: Can be traced in your pathway. Because the base is composed of illuminating subjects.
- Incendiary: Contains phosphorus. It catches fire.
- Yawning: Slow and irregular bullet.
- Tandem: It is when the second bullet is pushing the first bullet. In this, two bullets are coming out, it is called tandem also known as piggyback bullets.
- Plastic or Baton bullet: It is composed of polyvinyl chloride and used in riot control.
- Poison bullet: Curare, resin. Any type of poison in a bullet is known as a poison bullet.

Ricochet bullet: If a bullet is deflected from any object, it goes into your body.

- Critical Ricochet angle is 30 degrees.
- Spin and rotation lost, so no abrasion collar.
- Burning, blackening, and tattooing all are absent.
- Round nose tip bullet - Round Tip
- Sharp nose bullet - Sharp pointed Tip
- Fully jacketed bullet - Copper jacket
- Semi-jacketed bullet - Nose is not jacketed, expanded inside tissues.

It can be of two types:

- Dum-Dum Bullets
- Hollow Pointed Bullets
- This causes more external damage due to expansion.

Kennedy Phenomenon:

- Surgical alteration of gunshot wounds. If it dies during the post-mortem, it is difficult to identify the entry, exit wounds, and range difficulty.

Rayalseema Phenomenon:

- Bullets are implanted in stab wounds to mislead the investigation.

Discharge from Gun- Effects:

- **Flame:** Causes burning of hair, charring, singeing
- **Smoke:** Smoke is deposited surrounding the skin. This phenomenon is known as blackening and smudging.
- **Unburned Gun Powder:** That is impregnated in the skin and known as tattooing, peppering, and stippling.
- **Projectiles from Shotgun:** Lead shot (wad), projectile from rifle (bullet)

MCQs

Q. Who is the father of ballistics.?

Ans. Calvin Goddard.

Q. Which instrument is used to examine the inner surface of barrel.?

Ans. Helixometer.

Q. Among the following, what are the advantages of rifling in a rifle?

- a) Increase the accuracy and speed
- b) It Causes gyroscopic stability
- c) Enhance the wound power.
- d) All of the above

Ans. d

Q. In which gun the barrel towards the muzzle end is rifled.?

Ans. Paradox gun.

Q. What acts like Piston and Lubricant?

Ans. Wad

Q. Most specific test of Gunshot Residue Test.?

Ans. Scanning electron microscope.

prince kumar
princeeeekum@gmail.com
9928609733



PREVIOUS YEAR QUESTIONS



Q. Assertion: Range of shot can be determined by the spread of pellets.
Reason: Shotgun cartridge contains pellets?

(AIIMS May 2019)

- A. Both assertion and reason are correct and reason is correct explanation of assertion.
- B. Both assertion and reason are correct but reason is not a correct explanation of assertion.
- C. Reason correct assertion wrong
- D. Both assertion and reason are wrong

Q. Bullet wipe term is used for? (AIIMS May 2019)

- A. Gutter fracture of skull
- B. Blackening
- C. Tattooing
- D. Dirt from barrel

Q. A middle aged lady was found in a robbed room lying in a pool 0-6 blood. On forensic examination there was an entry wound of size around 2 x 2 cm on the left temporal region with tattooing and blackening right temporal region. On further examination two bullet fragments were found inside the brain parenchyma. Which of following could be used to determine the distance from which the weapon was fired?

(AIIMS Nov 2017)

- A. Hair
- B. Clothes
- C. Bullet fragments
- D. Blood

Q. Bullet fingerprinting is?

(AIIMS Nov 2018)

- A. Human fingerprints on bullet
- B. Primary marking
- C. Secondary marking
- D. Distorted bullet

Q. The poisoning caused by bullet retained inside the body is?

(FMGE Dec 2019)

- A. Iron
- B. Phosphorus
- C. Nitro cellulose
- D. Lead



CROSS WORD PUZZLES



Crossword Puzzle

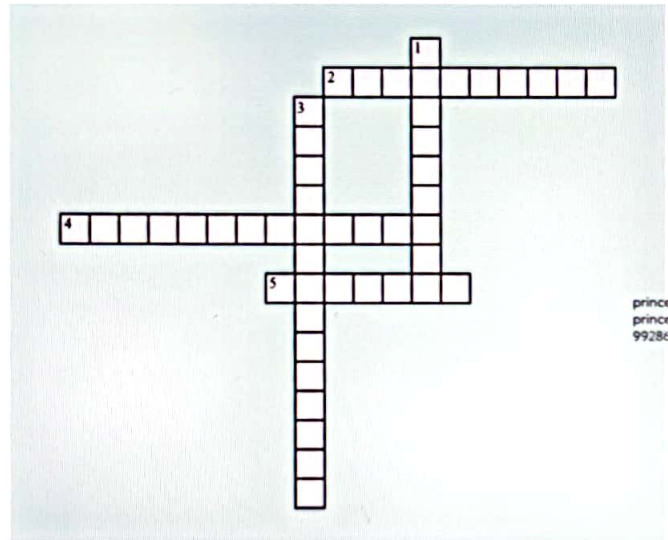

Across

- 2. mixed gun
- 4. Father of ballistics
- 5. It is used for rifled weapons.

Down

- 1. Loaded within firearm
- 3. Penetrate in living tissue

prince kumar
 princeeeekum@gmail.com
 9928609733



17

DISCHARGE FROM GUN EFFECTS



Discharge from Gun Effects

- Flame - Causes burns.
- Smoke - Causes blackening.
- Unburned gunpowder - Causes Tattooing
- Projectiles

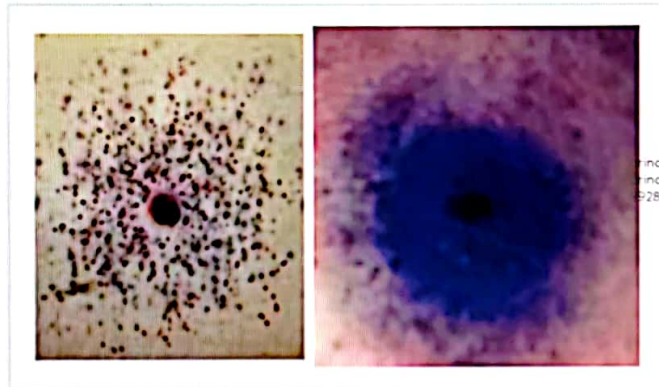

Range of Rifle and Shotgun

00:06:19

Range	Rifle	Shotgun
Flame (Burning)	7 cm	15 cm
Smoke (BL)	30 cm	45 cm
Gunpowder (TAT)	60-90 cm	60-90 cm

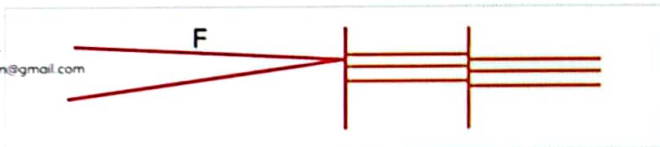

Contact Shot - Rifled Weapon

Refer Table 17.1

Rifled Firearm

	Contact	Close shot	Near	Distant
Muzzled Impression	+	-	-	-
Shape of wound	Stellate	Circular	Circular	Circular
Burning/Blackening/Tattooing	All present, that too inside the track	All present	Only Tattooing	-
Grease or Abrasion collar	+	+	+	+

Burning vs Tattooing

- Cotton cloth is immersed in water and wiped at the site.
- Blackening - Black color wiped out.
- Tattooing - Not wiped out.

Grease Collar vs Abrasion Collar

- Present an entry wound.
- Usually seen in rifles.

Grease Collar	Abrasion Collar
Produced by the grease of bullet	Produced by spin or rotation of the bullet
More specific	Comparatively less specific
Inner side	Outer side
	Gives an idea about angulation. <ul style="list-style-type: none"> • Perpendicular entry - Round Collar • Oblique entry - oval collar
	<ul style="list-style-type: none"> • Absent in palm and soles, and if the bullet isn't spinning. • If the person is attached to a surface, can be found in exit wounds as well - that is called Shored exit wound

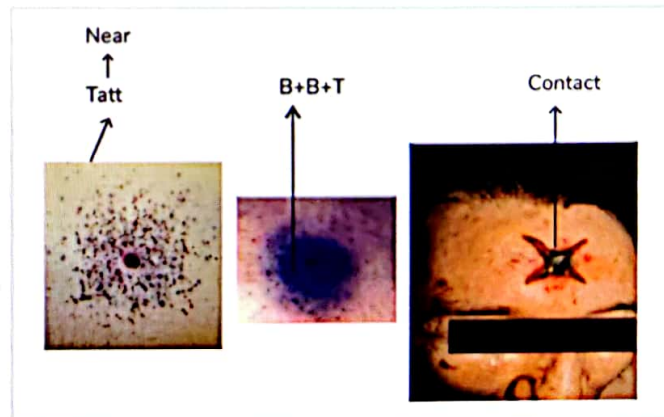
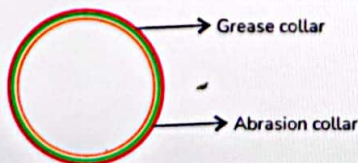

Entry vs Exit Wound

Character	Entry Wound	Exit Wound
Size	Small	Large (except in contact)
Margins	Inverted V	Everted ^
Abrasion and Grease Collar	+	-
Burning + Blackening + Tattooing	+	-
Bleeding	Less	More
Cherry red color (due to CO+Hb)	+ (maybe)	-
Fat and soft tissue expulsion	-	+

Metal Fouling

- Tiny lesions around the entry wound formed by
 - Surface of missile (bullet)
 - Interior of barrel

Bullet Fingerprint

- **Primary marking**
 - Rifling of barrel
 - Gives model of weapon or gun.
 - Class characteristic
 - Land/ groove
- **Secondary marking**
 - Irregularity inside the barrel
 - Cleaning
 - Manufacturing defects
 - Wear and tear inside
 - Individual characteristic
 - If striations are present - A comparison microscope is used

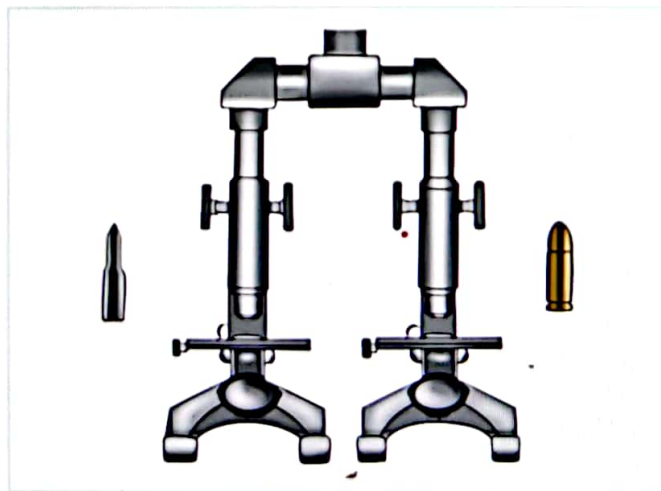

◦ If same striations, same brand bullets

Q. Which is a gross bullet fingerprint marking

Ans. Primary marking

Q. Which is a microscopic bullet fingerprint marking

Ans. Secondary marking

Beveling of Skull

- Cone-shaped bone erosion

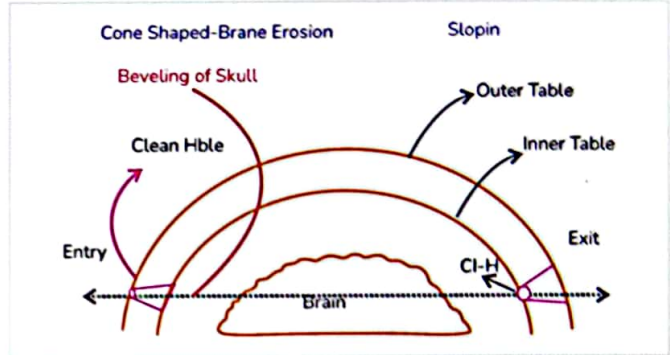

Beveling of Skull phenomenon

- Going to any table - Clean wound
- Coming out from any table - Cone-shaped erosion

One Liners

- Beveling is always seen at the exit point of the table.
- In entry wound Beveling is towards the inner table.
- In exit wound Beveling is towards the outer table.

prince kumar
princeeeekum@gmail.com

Puppes' Rule

- Used for sequencing of bullets.

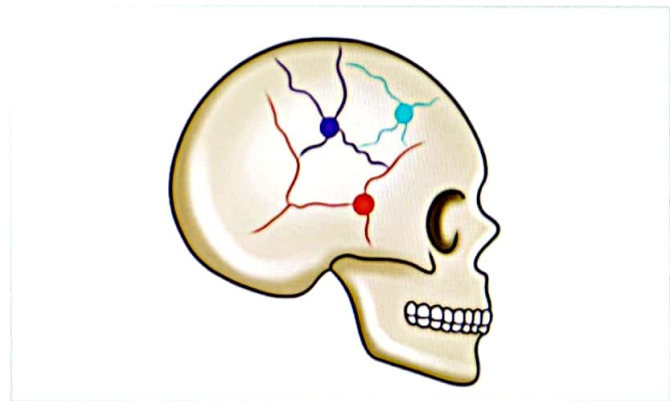

- 1st fracture line - Normal
- 2nd fracture line - Never crosses 1st line.
- 3rd fracture line - Never crosses 1st and 2nd lines.

Kronlein Shot

- Range - Close
- Skull - Brusted
- Brain - Evisceration

Shot-Gun

- Lead shot/ pellets
- Gunpowder travel: 60 to 90 cm
- Blackening + Burning + Tattooing: Till 1 m
- Dispersion of pellets start: >2 m (intermediate)
- Complete dispersion: >4 m
- Wad lesion: 2m

Refer Table 17.2

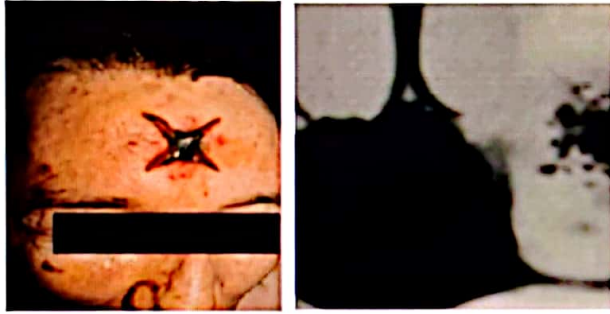

Billiard Ball Effect vs Balling/ Welding

- Both are atypical patterns of Shotgun injury

Billiard Ball Effect	Balling/ Welding
<ul style="list-style-type: none"> • Dispersion of short pellets • Lead shots will disperse in high range when they strike any surface. • Other name: Billiard Ball Ricochet Effect • Dispersion is very high • Range is short 	<ul style="list-style-type: none"> • Sticking of Lead shots • Distant range shots will stick together, maybe due to melting down of lubricant or fragments. • Large entry wound + Some dispersion • Dispersion is less. • Range is long. • Will give the appearance of a satellite (but not intermediate)

Range	5 metres	10 metres	15 metres	20 metres	
Cylinder	20	50	60	75	dispersion in cm
Half choke	13	30	40	50	
Full choke	8	25	35	45	

Table of Different Ranges of Different Shotguns

- Mnemonic: CHF

Blast Injuries (Bomb Blast)

00:39:22

Types

- Air blast (midair)
- Underwater blast (liquid or water)
- Solid blast (on solid surface) - Ex: Mine blast
- Products of the Blast
 - Airwave/ blast wave/ shock wave-Air compression is seen.
 - Flying missiles/ projectiles/ objects-Flying pieces, needles, and other sharp objects may hit people.
 - Lifted and thrown around - Person may hit ground, tree, etc.
 - Miscellaneous - Building collapse, burns, and fumes may give injury.

Primary Blast Injuries (Airwave or blast wave)

- Barotrauma - Due to blast wave
- Hollow organs
 - Ear
 - Most common tympanic membrane is affected (bleeding, perforation)
 - Ossicles
 - Lungs
 - Most fatal injury
 - Alveoli, capillaries, basement membrane all are damaged (blast lung)
 - GIT
 - Vomiting
 - Malena
 - Perforation

Secondary Blast Injuries (Flying objects)

- Marshall's triad is produced.
 - Punctate abrasion
 - Punctate contusion
 - Punctate laceration

Tertiary Blast Injuries (Throwaway due to air/wind)

- May hit other objects like ground, or hard surfaces as such.
- Leads to skeletal fractures or injuries.

Quaternary Blast Injuries

- Building collapse - Traumatic Asphyxia
- Burn/ Fire/ Flame injuries.

Quinary Blast Injuries

- Environmental contaminants
- Chemicals (Cl, Savin)
- Radiations (nuclear bomb)
- Virus and bacteria (bio wars)

Bomb

- Having explosive materials.

Types

- **Incendiary bomb**
 - Contains phosphorus and magnesium.
 - Catches fire.
- **Molotov Cocktail**
 - **Other name: Petrol bomb**
 - **Half bottle is filled with petrol.**
 - Rag is present for ignition.

 **Important Information**

Most Common Organ Injured

- **Air blast** - Tympanic membrane > Lungs
- **Underwater blast**
 - Nothing mentioned - GIT.
 - Head below water - Tympanic membrane
 - Head above water - GIT



Table 17.1

Close Contact	Loose Contact	Bone Contact
<ul style="list-style-type: none"> • Circular entry wound • Muzzle impression • Blackening/ Burning/ Tattooing inside • Blood and tissue may enter the barrel (Back spatter) 	<ul style="list-style-type: none"> • Smoke layer is formed (Corona) 	<ul style="list-style-type: none"> • Energy + expanding gasses, cause skin rupture (blowback phenomenon) • Stellate/ cruciate shape wound.
		
		Stellate/ cruciate shape wound

Table 17.2

Characteristic	Contact Shot	Close Range (1m) O	Near Range (1-2m) R	Intermediate-Range (2-4m) S	Distant Range (>4m)
Entry wound appearance	Stellate/ cruciate	Circular (O)	Rat-hole (nibbled margin)	Satellite (large multiple palettes)	Individual palettes
Muzzle impression	+	-	-	-	-
Blackening/ Burning/ Tattooing	Inside the track	All	Only tattooing	-	-

prince kumar
princeekum@gn
9928609733



CROSS WORD PUZZLES



Crossword Puzzle

Across

- 4. Environmental contaminants

Down

- 1. Petrol bomb
- 2. gross bullet fingerprint marking
- 3. Contains phosphorus and magnesium

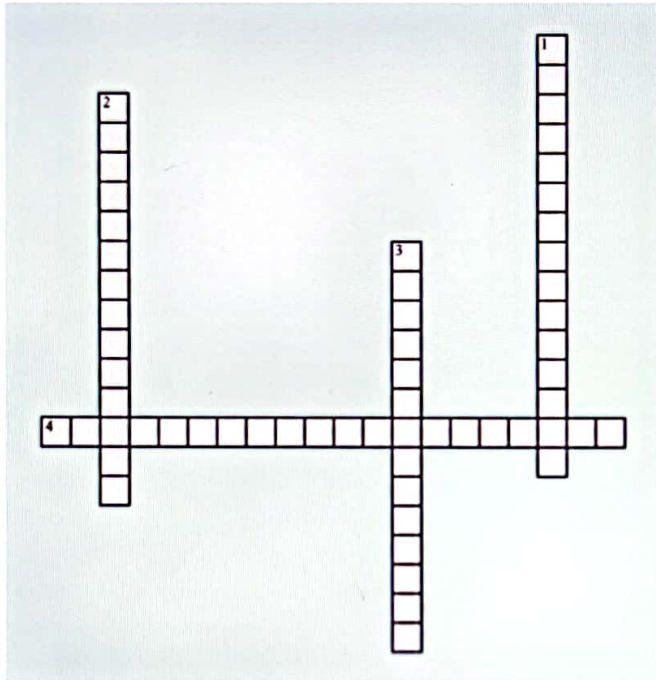

prince kumar
 princeeeekum@gmail.com
 9928609733

18

IDENTIFICATION PART - 1



Corpus Delicti

- **Means:** Body of offense/crime
- Also known as the essence of crime
- Components of Corpus Delicti
 - Crime
 - Reason (motive of the crime)
 - Source of evidence
 - Dead body
 - Crime scene evidence
 - Primary and secondary evidences ((blood stain, seminal stain, blood stain on clothes)

Identification prince kumar
princeeeekum@gmail.com
609733 00:01:53

- Age, sex
- Race and religion
- External peculiarities (tattoos, scars, moles)
- General development, complexion, and stature
- Anthropometric measurements (length of bone, stature)
- Fingerprints (Galton system) and Footprints (Podogram)
- Teeth

Race

- **Negroid**
 - Africans
 - Pure Aryans
- **Mongoloid**
 - Japanese
 - Few Americans
- **Caucasoid**
 - Europeans
 - Chinese

Cephalic Index

- Index of a skull bone
- **3 types**
 - **Dolicocephalic**
 - Value: 70-74.9
 - Negros, Pure Aryans
 - **Mesaticephalic**
 - Value: 75-79.9
 - Indians, Chinese, and Europeans
 - **Mnemonic: M-ICE**
 - **Brachycephalic**
 - Value: 80-84.9
 - Mongol

Note: Brachycephalic is due to Early fusion of the coronal suture

Cephalic Index = $\frac{\text{Breadth of skull bone}}{\text{Length of skull bone}} \times 100$

Golden Points

- Indians are not pure Aryans.
- Indians have both Dolichocephalic and Brachycephalic features (Mesaticephalic)
- Caliper is used for measurement

Other Indices

- **Mnemonic: BCCI**
- **Brachial Index**
 - Length of Radius/Length of humerus × 100.
 - Upper limb index.
- **Crural Index**
 - Length of Tibia/Length of Femur × 100.
 - Lower limb index.
- **Cephalic Index:** Skull bone index
- **Intermembral Index**
 - Length of Humerus + Radius/ Length of Tibia + Femur × 100.

Orbit and Palate

Part	Negro	Mongol (Gol = Round)	Caucasian (C 3rd letter, 3 for Tri)
Orbit	Square	Round	Triangle
Palate	Rectangular	Round	Triangle

Teeth

Negro	Mongol (PE S T)	Caucasian (C C)
More cusp	<ul style="list-style-type: none"> • PE - Premolar Enamel pearl • S - Shovel-shaped incisor • T - Taurodontism (Bull tooth) • Congenital absence of 3rd molar can be present 	Carbelli Cusp (maxillary molar)

Hair

Feature	Negro	Mongol (Gol = Round)	Caucasian
Cross section	Elliptical	Cylindrical/ Round	Round to oval
Medulla	Fragmented	Non-fragmented	Fragmented
Cuticle	Absent	Thick	Medium

Sexual Differentiation

00:14:52

Methods

- External morphology
- Sex chromatin
- Sexing of skeletal remains in death.
- Gonadal biopsy (confirmatory method).

Sex Chromatin

• **2 bodies**

○ **Barr body**

- It is a plano-convex nuclear mass near nucleus.
- Present in somatic cells (buccal mucosa, saliva, hair follicle).
- It is an inactivated X chromosome.
- Female 20-80%.
- Male 0-4%

○ **Davidson body**

- Blood sample is taken.
- Present in 6% of Female Neutrophils.
- Drumstick appearance.
- Absent in males.
- Better indicator compared to Bar body.

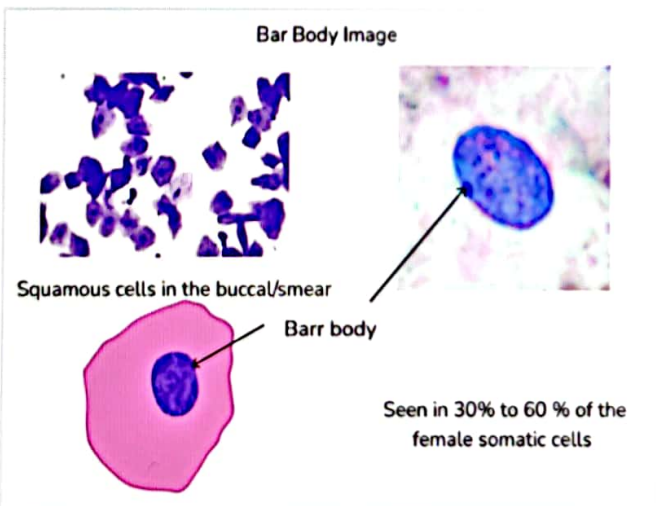

Refer Image 18.1

• **2 reactions**

○ **Feulgen reaction**

- Used for the X chromosome.
- **Stain:** Acriflavin
- **End point:** yellow color

○ **Quinacrine Staining**

- Used for the Y chromosome.
- **Mnemonic:** Qui means Why (Y)

Sexing of Skeletal Remains

- Given by Krogman
- Known as Krogman Table

Part	Accuracy
Entire skeleton	100%
Pelvis and skull	98%
Pelvis alone: Single best bone	95%
Skull alone	90-92% (Go for 90%)
Long bones alone	80%

Differentiating Male and Female Skeleton

Characteristic	Male	Female
Bones	Large Heavy	Small Light
Prominence (Muscles) Ridges	More prominent	Less Exception Frontal eminence Parietal eminence
Glabella	More prominent	Less prominent
Supraorbital ridge	More prominent	Less prominent
Zygomatic Arch	More prominent	Less prominent
Orbits	Square	Round
Forehead	Steeper	Vertical
Palate	Large U Shape	Parabola Small
Angle	Less	More
Sub Pubic angle	70-75	>90
Mandible	<125 Less obtuse	>125 More obtuse
Shape	Square	Round
Obturator foramen	Oval	Triangular
Chin	Square	Round
Chilotic Line (M S)	Sacral Length	Pelvic ↑
Index (Value)	↓144	↑166
Sciatic notch (Best index)	↓	↑
	$\frac{\text{width}}{\text{depth}} \times 100$	prince kumar princeeeekum@gmail.com 9928609733
Sacral Sacrum bone	↓	↑
Sternal		



Washburn or Ischio-Pubic Index $\frac{\text{Length of pubic}}{\text{Length of ischio in 200}}$	↓ <95	↑ >95
Corpobasal $\frac{\text{Breadth of 1st sacral vertebra}}{\text{Breadth of base of sacrum}} \times 100$	↑	↓
Chilotic Line Index	↑	↓
Pelvis(inlet)	Heart shape	Oval
Shape	Deep funnel	Flat Bowl
Greater Sciatic notch (Best parameter)	↓ Small Narrow and deep	↑ Wide large and shallow
Ischial Tuberosity	Inverted	Everted
Preauricular sulcus aka Tertiary sexual character	Less frequent or very rare	More frequent
Sacrum	Long and narrow 3	Short and broad 2-2.5

Example

Age of Fetus	Length
1	1
2	4
3	9
4	16
5	25
Next 5 months	
6	30
7	35
8	40
9	45
10	50

Things To remember.

- 1st month: Limb buds appear.
- 2nd month: Webbing of hand and feet.
- 3rd month: Nail appears, pupillary membrane,
- 4th month: Lanugo hair, Sexual differentiation.
- 5th month: Scalp hair appears.
- 6th month: Eyebrows, eyelashes vernix.
- 7th month: Eye open, pupillary membrane disappears.
- 8th month: Nail grows at the tip, left testis goes into the scrotum.
- 9th month: Right testis goes in scrotum

Ossification Centres

00:42:29

- Appearance of the center
 - Appears in 5-6 weeks.
 - Appears 1st: Clavicle.
 - In 5 months: Calcaneum
 - Seventh month:
 - Second and third piece of sternum
 - Talus
 - 36 weeks (9th month):
 - 3rd alphabet Capitate and cuboid
 - 6th alphabet Femur
 - Full term: Upper end of tibia

Elbow joint: Appearance of Centre

- Capitulum: 1yr
- Radial head: 3-4 yr
- Inner epicondyle(medial): 6yr
- Trochlea: 8yr
- Olecranon: 10yr
- External epicondyle: 11-12 yr

Ashley's S Rule

prince kumar
princeeeeekum@gmail.com
9928609733

A: Ashley Hyrtl's Rule

- Ashley Sternum Rule
 - Used in sternum bone.
 - Sternum length in males > 149mm.
 - Sternum length in females < 149mm.
- Hyrtl S Rule
 - Body is longer and more than twice the length of Manubrium in males.
 - Shorter and less than twice the length of manubrium in females.

Age of Fetus

00:35:37

- Rule of Hasse: First 5-month age of the fetus

$$\text{Month} = \sqrt{\text{Length (cm)}}$$

- Length: CHL Crown heel length
- Modified Morrisons rule: Next 5 months.

$$\text{Month} = \frac{\text{Length}}{5\text{cm}}$$

- CRL = Crown-rump length = $\frac{2}{3}$ CHL

Carpal Bone Fusion

- Lateral to medial.
- Proximal
 - 12-year rule = 5+4+3
 - She Looks Too Pretty
 - Scaphoid = 5yr
 - Lunate = 4yr
 - Triquetral = 3yr
 - Pisiform(last) = 12 yr
- Distal
 - Try To Catch Her
 - Trapezium - 6 yrs
 - Trapezoid - 6 yrs
 - Capitate: 1st carpal bone to be fused - 1 yr
 - Hamate: 2nd Carpal bone to be a fuse - 2 yrs

Fusion

- TRY
 - TriRadiate Cartilage of Acetabulum (13-15 yr)
- IIT
 - Iliac crest: 20yr
 - Inner end of clavicle: 21yr (Medial end of Clavicle 22-25yr)
 - Tuberosity Ischial: 22yr

Upper Limb Fusion Vs Lower Limb Fusion

Upper Limb	Age	Lower Limb	Age
Shoulder	18	Hip	17-18
Elbow	16	Knee	18
Wrist	18	Ankle	16-17

Important Information

Female Ossification center fuses: Comparatively 1-2 years earlier.

Skull fontanelles

- Anterior Fontanelle - Bregma (18-24 months)
- Posterior Fontanelle - Lambda (3 month)
- Lateral Fontanelle
 - Anterior: 2 (Sphenoid)
 - Posterior: 2 (Mastoid)

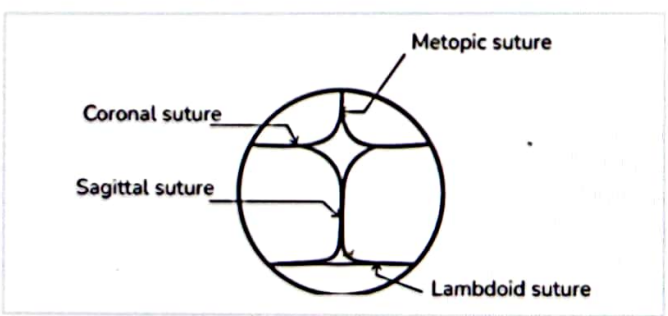

Skull Sutures

- 1st Suture: Metopic at 9 months
- Last Suture: Squamous temporal >= 80 yr
- Saggital (best):
 - Posterior 1/3 20-40 yrs
 - Anterior 1/3 40-50 yrs
 - Middle 1/3 >50 yrs
- Coronal:
 - Upper half → 50-60yrs
 - Lower half → 40-50yrs
- Lambdoid:
 - Upper half → 50-60 yrs
 - Lower half → 60-70 yrs
- Basiocciput with Basisphenoid:
 - 18-21 years
- Lateral skiagram

Sternum

- Appearance
 - Manubrium and 1st piece take 5 month of IUL (Fuses at 40-60 yrs)
 - 2nd and 3rd piece takes place in 7 months.
 - 4th piece 1yr.
 - Xiphoid in 3-4yrs (4th and xiphoid at 40yrs).

Sternum

- Sacrum: becomes a single bone
 - In 20 to 25 yr
- Two halves of the mandible
 - In 2 yrs
- Greater cornu of hyoid with the body.
 - 40-60yr

Dentition

- Can decide the age of the children.
- Temporary teeth: 20
- Permanent teeth: 32
- Formula:

Temporary

Molar	Premolar	Canine	Incisor	Incisor	Canine	Premolar	Molar
2	0	1	2	2	1	0	2
2	0	1	2	2	1	0	2

Permanent Teeth

Molar	Premolar	Canine	Incisor	Incisor	Canine	Premolar	Molar
3	2	1	2	2	1	2	3
3	2	1	2	2	1	2	3

The sequence of Eruption of Temporary Teeth

Teeth	Molar	Premolar	Canine	Incisor
Age	12m	24m	18m	6m

To Remember

- Lower central incisor(6m) > upper central incisor(7m) > ULI (8m) > LLI (9m)
- All temporary teeth come in 24 months (2- 2.5 yr)
- Mummy: 6 yr (molar 1) =4
- Is: 7 yr (Incisor 1) =4
- In: 8 yr (Incisor 2) =4
- Pain: 9 yr (PM 1) =4
- Pappa: 10 yr (PM2) =4
- Can: 11 yr (Canine) =4
- Make: 11-12yr (molar 2) =4
- Medicine: 17-25 yr (molar 3) =4
- Total= 32
- 1st permanent eruption in 6th year

Permanent and Mixed teeth

- At 6yrs: 4 permanent and 20 temporaries.
- At 6-11yr: 4 temporary will decrease and 4 permanent will increase.
- Mixed dentition: Teeth after 6yrs.
- Example
 - At 6 yr 20 temp and 4 permanents.
 - At 7 yr 16 temp 8 permanents.
 - At 8 yr 12 temp 12 permanents.
 - At 9 yr 8 temp 16 permanents
 - At 10 yr 4 temp and 20 permanents.
 - At 11 yr 0 temp 24permanents.
- 12-14 yr 28 permanents.
- 17-25 yr 32 permanents.
- Last molar is a wisdom tooth.
- Successional
 - Permanent in place of temporary
 - 20 teeth

SUCCESSIONAL Teeth	SUPERADDED TEETH																																				
Permanent in place of temporary	No replacement, added on extra																																				
<table border="1"> <tr> <td>3</td><td>2</td><td>1</td><td>2</td> <td>2</td><td>1</td><td>2</td><td>3</td> <td>P</td> </tr> <tr> <td>2</td><td>0</td><td>1</td><td>2</td> <td>2</td><td>1</td><td>0</td><td>2</td> <td>= T</td> </tr> <tr> <td>2</td><td>0</td><td>1</td><td>2</td> <td>2</td><td>1</td><td>0</td><td>2</td> <td></td> </tr> <tr> <td>3</td><td>2</td><td>1</td><td>2</td> <td>2</td><td>1</td><td>2</td><td>3</td> <td></td> </tr> </table>	3	2	1	2	2	1	2	3	P	2	0	1	2	2	1	0	2	= T	2	0	1	2	2	1	0	2		3	2	1	2	2	1	2	3		12 Molar
3	2	1	2	2	1	2	3	P																													
2	0	1	2	2	1	0	2	= T																													
2	0	1	2	2	1	0	2																														
3	2	1	2	2	1	2	3																														
NUMBER: 20	12																																				

Superadded Teeth

- No replacement
- Added on extra.
- 12 molars

Other Methods for Teeth for Age Estimation

01:20:00

Stack formula

- Age group: Infant
- Weight and height of tooth used.

Boyd's method

- Age in terms of days.
- Best for the neonates.
- Striation developed in the enamel of teeth aka incremental lines.
- incremental lines are seen on electron microscope.
- Calculate the number of days after birth.
- 1st line is a neonatal line.
- After birth line can be seen in an electron microscope in 1- 2 days or 3 weeks by the naked eye.
- It is 1st and darkest line.

Gustafson Method

- Obsolete method not used now.
- >25yrs age
- Most common: Anterior teeth is Incisor.
- Molar is unsuitable.

Important Criteria of the Gustafson Method

- 6 x-ray criteria (SCRIPT)
 - Secondary dentine (2nd best)
 - Cementum Apposition
 - Root Resorption
 - Attrition
 - Paradentosis
 - Transparency of root of tooth (Best)

prince kumar
princeekum@gmail.com
9928609933

Dalitz method

- Modification of Gustafson's method.
- Criteria
 - Paradentosis
 - Attrition
 - Secondary dentine.
 - Transparency of root of tooth.

Lamendin Method

- Better Method
- Used in postmortem.
 - Paradentosis
 - Transparency of the root of the tooth

Dental Charting

1. Palmer notation (Zigmond's method)

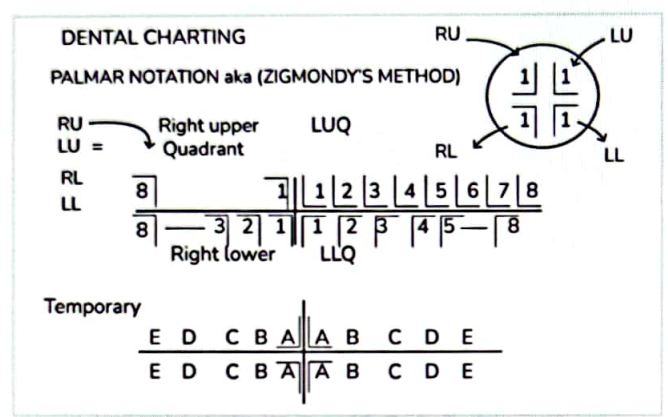

2. Haderup's System

- + for Upper.
- for lower.

+8	+7	+6	+5	+4	+3	+2	+1	+1	+2	+3	+4	+5	+6	+7	+8
-8	-7	-6	-5	-4	-3	-2	-1	-1	-2	-3	-4	-5	-6	-7	-8

Universal Method (Cunningham's)

- Permanent 1-32

1	2	3	4	5	6	7	8	9	10	11	12	13	14	15	16
32	31	30	29	28	27	26	25	24	23	22	21	20	19	18	17

- Temporary: A-J-K-T

A	B	C	D	E	F	G	H	I	J
T	S	R	Q	P	O	N	M	L	K

Federation dental International (FDI)

- Most commonly used worldwide.
- Most accepted method.
- For permanent prefix 1 2 3 4 added.

1 Right upper	2 Left upper
----------------------	---------------------

18	17	16	15	14	13	12	11	21	22	23	24	25	26	27	28
48	47	46	45	44	43	42	41	31	32	33	34	35	36	37	38

4 left lower	3 Left lower
---------------------	---------------------

- For temporary 5 6 7 8 prefixes added

5 Right upper	6 Left upper
----------------------	---------------------

55	54	53	52	51	61	62	63	64	65
85	84	83	82	81	71	72	73	74	75

8 left lower	7 Left lower
---------------------	---------------------

Modified FDI

1	2
18 17 16 15 14 13 12 11 21 22 23 24 25 26 27 28	31 32 33 34 35 36 37 38 41 42 43 44 45 46 47 48
3	

Picture of tooth given

- Anatomical chart formula

Images 18.1

Other tissue from which Barr bodies can be studied
Corneal epithelium, vaginal mucosa, fibroblasts etc.
Also seen in polymorphonuclear leukocytes in peripheral blood smears



Variable forms

Drumstick- Most Common Small deeply stained nuclear mass of about 1.5 μ in diameter, attached to the body of the nucleus by means of a thin stalk. 1% to 17% with an average of 2.9%

Others Racquet forms, sessile nodules, small clubs and minor lobes



prof William Mackay Davidson (1909-1991) Scottish pathologist hematologist

Davidson body



CROSS WORD PUZZLES



Crossword Puzzle

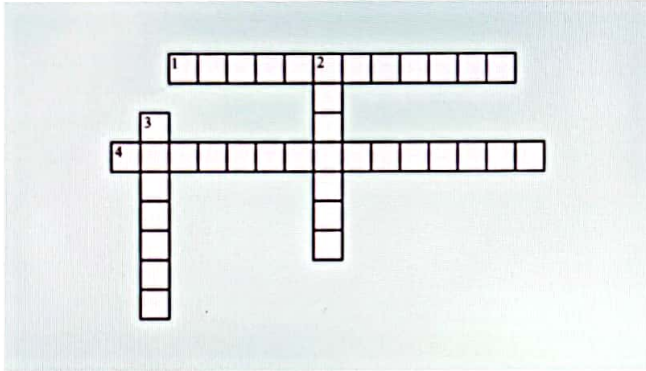

Across

- 1. Metopic at 9 month
- 4. Used for X chromosome

Down

- 2. Manubrium
- 3. Africans

prince kumar
 princeesekum@gmail.com
 9928609733



19

IDENTIFICATION PART-2



Stature-Best Bone

- Best bone to decide stature is the femur bone.
- Stature is the height.
- By bones we can decide the stature.

Regression and Formula

- Karl and Pearson formula
- Trotter Glessor formula
- **How to get the multiplication factor?**
- **Fe THUR**
 - Femur=3.7
→ Add 0.8 for 3.7 in rest (Except radius)
 - Tibia/Fibula=4.5
 - Humerus= 5.3
 - Ulna= 6.1
 - Radius= 6.5
- If the length of the femur given as 30cm
 - You can decide the stature.
 - $30 \times 3.7 = 111 \text{ cm}$
 - Percentage is around 27% of the length of the body.
- If a vertebral column is given, it is 35% of the stature of the whole body.

Length of Bone

- Measure by **Hepburn osteometric bone**



Stature from bony fragments

- Steele's formula
- Bidmos formula

Medicolegal Importance of Different Ages

00:05:12

- **1Yr** Below of 1 year is infant.
 - Killing an infant is infanticide.
 - Same IPC as age
- **7yr:** Below 7 yr no one is a criminal.
 - 82 IPC
- **7-12 yr:** Can be responsible for the crime if attained maturity.
 - It should be decided by a psychiatrist.
 - 83 IPC

12yr:

- Below 12 yrs no oath required.
- Consent is not valid: 90 IPC.
- Consent from guardian or parents: 89 IPC
- >12yr can give consent for physical examination.

14yr:

- <14 Cannot work in the factory according to factory act.
- 14-18 years can work in non-hazardous factories for fixed hours
 - Maximum 6 hours
 - Require fitness certificate.

16yr:

- <16yr kidnapping age of boy.
- <18yr kidnapping age of girl.
- 361 IPC
- Below 18 child is known as **juvenile**.
- At 18 you become major
- License in 18
- Marriage age for girl is 18.

20yr:

- Major In courtship above 21yr
- Marriage age for a boys is 21yr.

To Remember

- **Procuring a girl for sexual intercourse in India:** age is below 18.
 - Punishable under 366 A IPC
- **Procuring a girl's sexual intercourse from any country:** Aged below 21.
 - 366 B IPC

Identification Method

00:11:28

- **Most reliable method:** Fingerprinting aka Dactylography, galton system
 - Best method
- **Not inherited and not same** in identical twins or other people (Quetlet rule).
 - Fingerprints are the papillary ridges of skin.
- **World 1st finger-print bureau:** in Kolkata 1897
- First used by William Herschel in 1858
- **Classification:** Galton system
- **In fetus life:** In 12-16 weeks starts and completes in 24 weeks.

1. Fingerprint

Types

- **Visible:** Visible on the stain, like blood
- **Latent (Chance):** invisible or barely visible.
- **Plastic:** Which is on the soap surface, cheese surface.



Pattern

o (Love wife and children)

→ **Loop (common):** 70% of the population

- Like hairpin
- Ridges come towards each other.

→ **Whorl:**

- Just like a circle

→ **Arch:**

- Diverges.
- Just like mountain

→ **Composite:**

- Least common
- 1-3% of the population
- Mixed pattern

prince kumar
princeeeekum@gmail.com
9928609733

Minimum Comparison Points

- 10-12
- Variable from state to state.
- Histological section is up to 0.6mm in depth.

Altered Fingerprint

- Permanently lost:
 - o Leprosy
 - o Electric burn
 - o Radiation
- Complete loss of pattern with ridges atrophy.
 - o Celiac Disease
- Incomplete ridge Atrophy
 - o Dermatitis
- Ridge alteration
 - o SEA
 - Scleroderma
 - Eczema
 - Acanthosis nigricans
 - Skin atrophy
- Pattern retained but the change in the distance between ridges: (AIR All India Radio)
 - o Acromegaly
 - o Infantile paralysis
 - o Rickets

No Fingerprint

- No fingerprint Syndrome
 - o Adermatoglyphia
 - o Baird syndrome
 - o Zinsser-cole syndrome

Latent Fingerprint-Visible

- **Fabric:** 5%
 - o Use AgNO3
- **Paper:** Vapor of iodine or Osmium Tetroxide
- **Glass by:** Scanning electron microscope
- Live scan of fingerprint captured by: O-FTIR
 - o Optical Frustrated Total Internal Reflection
- Computerized automated system used for biometric fingerprint.
- Left thumb is commonly used for civil purposes.

2. Poroscopy Pores

- Unique method of Identification.
- Discovered by Edmod Locard
- **Locard Exchange principle**
- Each mm of fingerprint has 9-18 pores.

3. Palatoscopy

- Study of the hard palate
- Aka Rugoscopy: Rugae
- Discovered by Allen
- **Hard Palate:** Anterior 1/3 rd of the hard palate contain rugae.
- Rugae are individually unique for each person.



- Ridges coming towards each other is core.
- Ridges coming from 3 directions its delta.
- **Loop:** 1 core and 1 delta
- **Arch:** No core or delta
- **Whorl:** 2 delta and no core

Matching of Fingerprint

1. Pattern: Level 1

- Loop, whorl, arch or composite

2. Ridges character: Level 2

- Termination: Ridge terminated
- Bifurcation: divided into 2 parts
- Independent
- Point: Island
- Lake: Like a lake
- Spur
- crossover
- **Patterns:** Are known as minutiae
- **Study of minutiae:** Ridgeoscopy

3. Part of the ridge: That contains pores: level 3

- Pore is opening of sweat gland.
- Size
- Number
- Shape
- Edges
- Location
- Study of pore along the ride is **Edgeoscopy**
- Study of the individual pore is **poroscopy**

- **Primary Rugae:** p for palm: 5-10mm
- **Secondary Rugae:** 3-5mm
- **Tertiary: Rugae:** 0-3 mm

4. Cheiloscropy

- **C - Car**
- Study of lip prints
- Classified by: Suzuki.
- In the car we like **A/C**
 - Aqua print
 - Cyanoacrylate
- **5 types**
 - Complete and partial straight groove
 - **Forked** grove.
 - Branched grove.
 - **Intersecting** grove
 - **Reticular**
 - Reticular pattern
 - **Undetermined** (Any pattern)

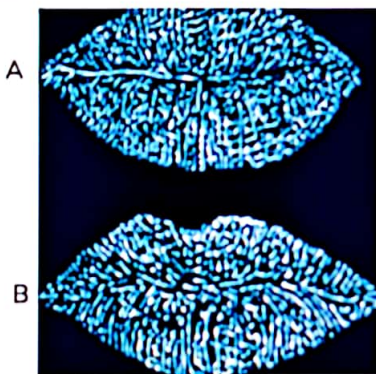

prince kumar
princeekum@gmail.com
9926609733

5. Tattoo Mark

- Injecting dye into skin
- Dyes we use.
 - **VIPCar**
 - Vermillion Dye
 - Indigo dye/India ink dye
 - Prusian blue
 - Cinnabar dye, Cadmium dye, cobalt
- Inject in the depth of dermis.
- Goes in the regional lymph nodes.
 - Can detect this by regional **lymph node biopsy**.
- For Old tattoos marks we use IR rays.
- For faded we use UV rays

Tattoo Mark Removal

- **Methods: ABCDE**
 1. Surgical Ablation
 2. laser Beam or burn.
 3. Chemical or caustic
 4. Dry ice
 5. Electrolysis, excision, and grafting, enzymes like papain.

- **Case:** Sydney shark Arm case
- **Used in:**
 - Personal identification
 - Regional identification
 - Place identification
 - Political mark
 - Drug IV
 - Homosexual (bluebird tattoo mark)

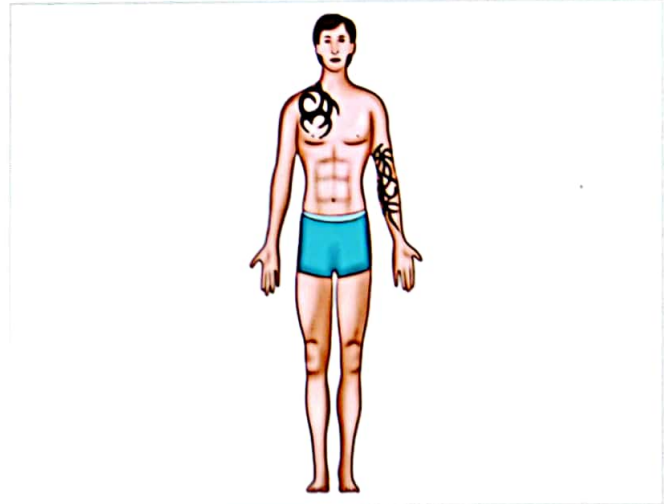

6. Podogram

- Study of footprint
- It is used in a maternity hospital.

7. Superimposition technique

- **S:** Screening test, skull, and superimposition
 1. Photograph of skull bone
 2. Photo of face
 - Superimpose with face photo.
 3. Anatomical landmark
 - Matching or not matching
 - Not matching is important.
 - It means the test is negative.
 - It has importance.
 - Test of a negative value is more important.

Anthropometry

00:42:05

- Discovered by Bertillon
- Bertillon system or Portrae Parle
- **4 Criteria for identification**
 - Body mark
 - Tattoo or scar etc.
 - Body measurement
 - AKA **anthropological analysis**
 - Height
 - Descriptive data
 - Skin color, eye color
 - Photographs
 - **4 photographs** taken generally.



Scar

- Ages:

Duration	Features
5-6 days	<ul style="list-style-type: none"> • Reddish blue • Angry • Firm • Union
2 weeks-2 months	<ul style="list-style-type: none"> • Pale • Vascular • Soft • Tenderness present
2-6 months	<ul style="list-style-type: none"> • Brown • Tough • Glistening • Tenderness Mild
>6 months	<ul style="list-style-type: none"> • White • Tough • Non-tender

Frontal Sinus Pattern

- Important method of identification
- > 15 yr
- If X-ray available

Concealed Sex

- Hiding sex for the criminal intention.
- Case: Colonel Victor Barker

To Remember

- Pterion fuses: 65 years of Age
- Masto-Occipital fuses: 80 years of age

Squamous Temporal: More than 80 of years



CROSS WORD PUZZLES



Crossword Puzzle

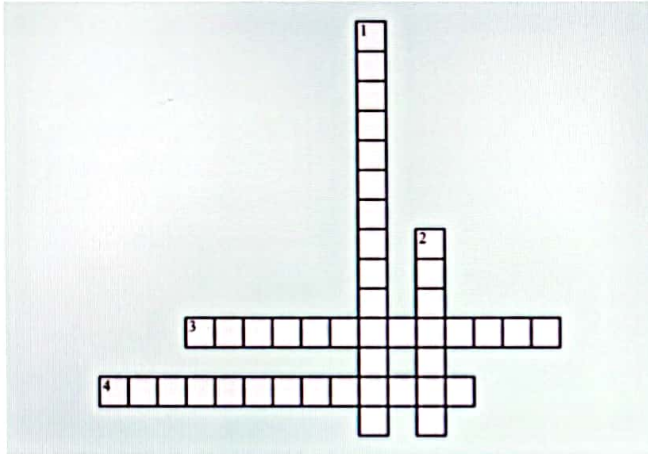

Across

- 3. Identification Method
- 4. Complete loss of pattern with ridges atroph

Down

- 1. Unique method of Identification
- 2. Altered Fingerprint

prince kumar
princeeeekum@gmail.com
9928609733



20 GENERAL TOXICOLOGY PART - 1

- It is the study of poisons, their type, actions, signs and symptoms, and the management and treatment, and antidote of poison.
- Toxinology
 - Study of living toxin
 - Eg plant toxins, virus toxins, and bacterial toxins.
- Founder of modern toxicology - Orfila
 - Spanish toxicologist
- Father of modern toxicology - Paracelsus

Duty of doctor during poisoning

00:04:28

- Document (medico-legal certificate) is made.
 - MLC
 - Post-mortem report
- Preservation of Sample and Evidence.
 - Sample from gastric lavage.
 - Blood sample
 - Vomit sample
- Police Information
 - 39 CrPC-Any poisoning case doctor should inform the police.
 - 176 IPC - Non-compliance – punishable.
 - 177 IPC - False information to police – punishable.
 - 274 IPC - Drug - adulteration of drug – punishable.
 - 284 IPC - Negligence regarding poison - leading to death or damage.
 - 328 IPC-Hurt by poison with criminal intention - punishable.



Paracelsus

Orfila

Ideal Homicidal Poison

00:01:34

- Ideal homicidal poison is **Thallium**.
- Most commonly used homicidal poison.
 - Arsenic
 - Aconite
- Quality
 - Cheap and easily available.
 - Toxic enough to kill a person.
 - Colorless, odorless, and tasteless.
 - Causes a slow and gradual death.
 - Signs and symptoms should resemble natural diseases.
 - No antidote, no Post-mortem changes.
 - Rapidly destroyed in the body
 - Should not be detected by a doctor or Post-mortem.

Information to the police

- Related to 39 CRPC.
- Homicide
 - Must inform.
- Suspicious (suspicion of poisoning)
 - Must inform.
- Unknown substance consumed.
 - Must inform.
- Attempt of suicide (the person confesses that they committed suicide).
 - Not mandatory to inform.
- Any suspicion of suicide
 - Must inform.
- Patient death due to complications or during treatment
 - Must inform.
- Dead on arrival
 - Must inform.
- Dying declaration arrangement.
 - Patient with a sound mind wants to give a dying declaration.
 - It can be arranged by a doctor.

Ideal Suicidal Poison

- Ideal Suicidal poison is cyanide.
 - Not easily available
- Most commonly used Suicidal poison.
 - Organophosphate
 - Opioids
 - Sometimes, barbiturates
- Quality
 - Cheap and easily available.
 - Toxic enough to kill a person.
 - Tasteless
 - Capable of producing painless death.

NDPS Act

00:09:59

- Narcotic drugs and Psychotropic substances used.
- **Last minute point copy - Mnemonic**
- L - LSD
- M - MDMA (ecstasy)
- P - Phencyclidine
- Copy

- Cocaine
- Cannabis
- Opioid
- Poppy
- The NDPS act was implemented in 1985 and there are some illegal issues associated with it.
- If the Possession of the drug is in a small quantity.
 - Punishment 6m or 10k fine or both.
- If possession for commercial use - 10-20y + 1-2 lakh fine.
- Consumption
 - Rigorous 6m+20k
- Cultivation
 - 10y Rigorous imprisonment + 1 Lakh fine.

Old laws:

- Opium act
 - Opium act I - 1857
 - Opium act II - 1878
- Dangerous drug act
 - 1930

Drug and Cosmetic Rule

- Implemented in 1945
- Drug and cosmetic act - 1940
- Schedule C (trick - before c come B)
 - Biological drug
 - Formed by biological product.
- Schedule G (trick - with G comes H)
 - All hormones
- Schedule F (trick - FB - Facebook)
 - Blood product
 - Sera
 - Vaccine
- Schedule H (trick - HP laptop)
 - Prescribed
 - The drug has to be prescribed by RMP (registered medical practitioner)
- Schedule J (trick - faculty name JhamAD - AD)
 - Drugs not to be advertised.
 - AIDS
 - Blindness
 - Deafness
 - Diabetes

Mellitus

- Schedule X (trick - causes spoiling of life - X)
 - Drug abuse
- Schedule E (trick - you say "EEE" when taking poison)
 - Poison

Toxicological Analysis

- When someone dies from a poisoning case, toxicology analysis is done.
- Also known as chemical analysis.

- Note – The question comes on the preservative used.
- Viscera is used for a toxicology report.
 - Stomach and its content
 - Small intestine (30 cm of its proximal part and its content).
 - Liver around 500 gm with the gallbladder.
 - One-half of each kidney.
 - Half of the spleen.
- Apart from viscera we take.
 - 100 ml of blood from Peripheral veins
 - 100 ml of urine
- Preservative used.
 - For blood
 - Sodium fluoride
 - It inhibits glycolysis (enolase enzyme and inhibits the growth of bacteria).
 - Potassium oxalate - it is an anticoagulant.
 - For urine
 - Toluene (trick - same sound as urine when pronounced)
 - Thymol
 - For viscera
- A question can come -
 - The most commonly used preservative for viscera.
 - Sodium chloride (common salt) - its saturated solution.
 - It is cheap.
 - Ideal preservative
 - Rectified spirit (90 percent ethanol)
- Contraindication of rectified spirit (trick - PAPP don't use ethanol)
 - P - Phenol
 - A - alcohol
 - P - Phosphorus
 - P - Para aldehyde
 - A - Acetic Acid

Special Preservation

00:22:06

- Muscle (skeletal muscle of buttock): used when the body is putrefied.
- Body fat: used in Endrin, DDT.
- Bone, hairs, and nails: used in heavy metals.
- Lungs: used for either gaseous poison or volatile poison.
- Bile and gallbladder preservation: Used for
 - G- Glutathione
 - B - Barbiturate
 - Opioids
 - Nicotine
 - Alcohol
- Spinal cord: used for strychnine.
- Brain: used for cerebral poison or organophosphate.
- CSF: used for alcohol.
- Heart: used for aconite.

Special smell

- Fruity/sweet smell: from Ethanol, chloroform.
- Acrid smell: from paraldehyde, chloral hydrate.
- Rotten eggs smell/sewer gas smell: H₂S.
- Rotten fish smell: Aniline.
- Kerosene odour smell: organophosphate = Aromax
- Fishy or musty smell: Aluminum, zinc phosphide.
- Bitter almonds smell CN-(cyanide)
- Burnt rope smell: Cannabis.
- Shoe polish smell: Nike = Nitrobenzene
- Garlic
 - Arsenic:
 - Phosphorus (pizza) = Thallium
 - Some organophosphate - parathion = Tellurium

Colour of postmortem staining

- Cherry red: Carbon monoxide poisoning = CO
- Bright red: Brick red = CN-
- Dark brown
 - Mnemonic - PAN
 - P- Phosphate
 - A- Aniline (blue colour)
 - - Nitrite
- Black: Opium.
- Bluish green: H₂S.
- Bronze: Clostridium perfringens.
- Purple: Methanol
- Hypothermia: Bright pink colour

Poisons causing PCT necrosis.

- P- Phenol (another product is Lysol)
- C- Carbon
- T- Tetrachloride
- PCT is caused by mercury.

Gastric lavage**Gastric lavage Tube**

- Stomach wash
- Tubes used.
 - Ryles tube- Child.
 - Ewald/Boas tube- Adult.
- Ideal tube is Lavacutor tube.
- Ideal time is within - 3 hours.
- Done by Ewald/Boas tube (total length is 150cm and marking at a point 50 cm from tip).

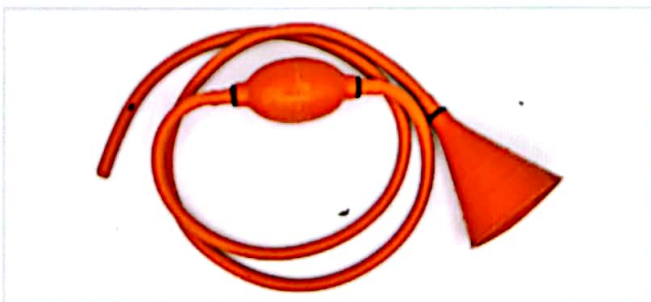
**Gastric lavage fluid**

- Warm water (35°C)/normal saline: Most common.
- Potassium permanganate (1:5000)
 - Even used in higher concentrations in opium poisoning.
 - Some poison even if they are taken from the parenteral route, we can go for gastric lavage.
 - Morphine, Cocaine, Amphetamine, Barbiturates.
- Sodium bicarbonate (5%)
- Tannic acid (4%)
- Sodium or potassium iodide (1%)
- Calcium lactate. (1-3%)

For heavy metals

- We give specific chemical antidotes in gastric lavage.
- Gastric lavage fluid is freshly prepared.
 1. Ferric oxide - Arsenic.
 2. Sodium formaldehyde sulphoxylate - Mercury
 3. Potassium ferrocyanide - Copper

prince kumar
princeeeekum@gmail.com
9928609733

Contraindication of gastric lavage

- Corrosive
 - Absolute contraindications
 - Corrosive causes blackening of mucosa and thinning of the mucosa.
 - So, if we are putting a tube in the mucosa there are chances of Perforation.
- Relative contraindication
 - C- Convulsant, comatose patient.
 - V- Volatile poison= kerosene= aspiration pneumonia.
 - Esophageal varices.
 - P- advanced Pregnancy.
 - H- heart disease hypothermia and hemorrhagic diathesis.
- Corrosive where we can go for gastric lavage is Carbolic acid.
 - Because in carbolic acid mucosa is not thin.
 - It is thick and leathery mucosa.

Complications of gastric lavage

- Aspiration pneumonia.
- Gastrointestinal perforation.
- Laryngeal spasms.
- Vagal inhibitions.

Universal antidote in gastric lavage

- Trick - Universally ATM is present (present everywhere)
- A- Activated charcoal
- T- tannic acid
- M- Magnesium oxide
- The ratio of A:T: M = 2:1:1

Activated charcoal.

- Black color
- Function of Activated charcoal
 - It adsorbs the poison on the surface.

- It is an example of a physical or mechanical antidote.
- Dose
 - 1 g per 1 kg of body weight

Tannic acid

- Causes precipitation of alkaloids.

Magnesium oxide

- Causes oxidation of Alkaloid
- Causes neutralization of acid

Coma cocktail

- If by poisoning someone goes into a coma it is administered
- Trick - DNB 1 (when appearing for DNB exam the first time you will go in comma)
- D - Dextrose
- N - Naloxone
- Vitamin B1 - Thiamine
- Naloxone helps with opioid-induced coma.
- Thiamine is used alcohol-induced coma.
- Dextrose helps in a coma due to Hypoglycemia.
- All this is given in combination.

Emetics

IPECAC

- Vomiting agent
 - It is a syrup given in 30 ml.
 - It is contraindicated in.
 - Corrosive
 - Convulsant
 - Coma
 - Hydrocarbon

Antagonism

- Types of antagonism or antidote
 - Physical antidote
 - Acts physically.
 - Mechanism
 - Adsorption
 - Eg charcoal
 - Coating
 - Eg milk or starch (Dimulsant)
 - Dissolving in it
 - Chemical antidote
 - It neutralizes chemically.
 - Eg
 - Acid is used for alkali poisoning.
 - Chelating agent - eg EDTA, penicillamine
 - Copper sulfate-neutralizes phosphorus poisoning.
 - Physiological antidote
 - Opposite function at different receptors or mechanism
 - Eg-Amyl nitrite is a physiological antidote for cyanide.
 - Converts hemoglobin to methemoglobin.

00:45:22

- Pharmacological antidote
 - Opposite action on the same receptor (Pharmacological antagonist)
 - Eg-in organophosphate, atropine & oxime are given.

Antidotes in different poisoning

- Paracetamol- N- Acetyl cysteine.
- Methanol.
 - Ethanol- a better antidote
 - Fomepizole
- CO poisoning - Hyperbaric oxygen
- Benzodiazepine - Flumazenil.
- Opiates - Naloxone, Naltrexone, or Nalmefene.
- Organophosphorus
 - Atropine
 - Oxime
- Cyanide (PYQ)
 - Amyl nitrate
 - Sodium Nitrite
 - Sodium Thiosulphate
 - All these are called triple antidotes or Lilly's antidotes.
- Thallium
 - Prussian blue
- Methemoglobinemia
 - Methylene Blue

Chelating Agents- USED IN

- Form chemical complexes with heavy metals.

00:51:24
prince kumar
princeekum@gmail
9928609733

British Anti Lewisite (BAL):

- Another name is Dimercaprol.
- It is a peanut oil suspension.
- It has two unsaturated sulfhydryl group which combine with the metals and prevents its union with SH of the respiratory chain.
- The complex is stable and easily excreted in the urine.
- BAL is administered in Deep intramuscular injection.
- Used in arsenic, lead, copper, mercury, thallium, and antimony poisoning.
- Contraindicated in Cadmium and Iron Poisoning, also in liver failure and G6PD deficient Individuals.

EDTA (Ethylenediaminetetraacetic acid)

- Contraindicated in mercury.
- Used in lead.

The trick to remember - LEAD.

In LEAD, we use EDTA first, then DMSA

DMSA- 2-3- Dimercaptosuccinic acid

- Can be given in many poisons.

Penicillamine

- It is a chelating agent for copper
- Contraindicated in arsenic.

Desferrioxamine

- Given in iron and heavy radioactive metals.

Contraindication for Hemodialysis

- Kerosene
- Benzodiazepines
- CuSo₄, chloroquine
- Heroine
- Organophosphate
- Digitalis.

Alkaline Diuresis

- Done when the poison is acidic poison.
- P- Phenobarbitone
- S- Sulfonamide
- M- Methotrexate
- Chlorpropamide

Acidic diuresis

- Acidification of urine
- Amphetamine
- Morphine
- Strychnine
- Quinine
- Cocaine

Stomach Mucosa

- Slate color: mercury
- Blackening: Sulphuric acid
- Yellow: Nitric acid, (due to xanthoproteic reaction).
- Buffed white: Carbolic acid.
- Blue/green: Seen in CuSo₄.
- Green: Ferrous sulphate.
- Blue: Amytal,
- Pink: Soneryl,
- Brown: Cresol,
- Gray, white/yellow: Phosphorous



CROSS WORD PUZZLES



Crossword Puzzle

Across

- 1. gastric lavage
- 4. used for aconite

Down

- 2. used for strychnine
- 3. Black color

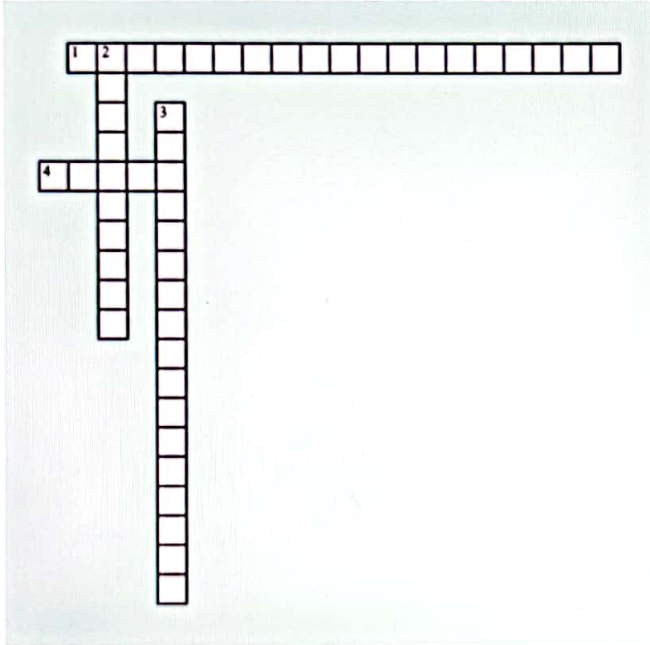

prince kumar
 princeeeekum@gmail.com
 9928609733



21

GENERAL TOXICOLOGY PART-2 (INSECTICIDE METALLIC AND NON-METALLIC POISON)



prince kumar
princeeeekum@gr
9928609733

Insecticide (Agricultural Poison)

1. Organophosphorus Poisoning- Suicidal
2. Carbamate
3. OC (Organochlorine)
4. Pyrethroids

Organophosphorus Poisoning

Most common suicidal poison.

Types:

- Alkyl = Po4 (Ex- Malathion, HETP, OMPP, TEPP).
- Aryl = Po4 (Ex- Parathion (folidol), Diazinon (Tik-20)).

Mechanism of Action

- Irreversibly inhibits a carboxylic esterase enzyme (AChE= Acetylcholinesterase enzyme)
- Sites:
 - 1st site is NMJ.
 - Ganglions of nervous tissue
 - RBC
- AChE is phosphorylated and irreversibly inhibited.
- Overall effect will be cholinergic.
- It also inhibits the Pseudocholinesterase enzyme present in Plasma, Pancreas, Liver, Heart, Brain
 - Also known as Plasma or Butyryl Cholinesterase.

Signs and Symptoms

- Appears when Cholinesterase level drops to 30% of normal activity.
 - Mild= 20-50%
 - Moderate = 10-20%
 - Severe= < 10%
- RBC/True Cholinesterase:
 - Most specific test.
- Plasma /Pseudocholinesterase:
 - Most common test because it Falls rapidly with Organophosphorus poisoning.
 - It is inexpensive.
 - Easy test
 - More sensitive test
- If giving 2 mg of Atropine in any case you are suspected of organophosphate Poisoning if the symptoms are relieved.
- Confirmatory test is the P-nitro phenol test.

Cholinergic Symptoms

- Muscarinic symptoms: overall secretion increased.
 - Diarrhea
 - Urination

- Miosis / Muscle weakness.
- Bronchorrhea, Bronchospasm.
- Bradycardia.
- Emesis.
- Lacrimation (red tear/ Chromodacryorrhea present because of Porphyrin secretion).
- Lethargic.
- Salivation

Nicotinic Symptoms

- Muscle weakness, Fasciculation, areflexia, muscle paralysis.
- Cause of death is RMP (respiratory muscle paralysis).
- CNS symptoms:
 - Headache
 - Tremor
 - Confusion
 - Slurred speech
 - Coma
 - Convulsion

Syndrome

00:12:50

- Acute: Increased Secretion
- Intermediate syndrome:

Seen in 1-4 days after acute poisoning, Because of prolonged cholinesterase inhibition and muscle necrosis. Proximal Limb Weakness occurs. It does not respond to oximes or atropine rather we required supportive symptomatic treatment.
- Organo-Phosphorous Induced Delayed Neuropathy:

Polyneuropathy due to distal muscle weakness. This also does not respond to oximes or atropine rather we required supportive symptomatic treatment.

Management

- Resuscitative Measures (Airway-Breathing-Circulation).
- Gastric Lavage with 1:5000 KMNO₄
- Activated Charcoal which adsorbs the poison.
- Atropine sulfate arrests the muscarinic effect but does not affect the nicotinic action.
- Should be continued till the Atropinization (Till the Tracheo-Bronchial secretion are clear or dry lung).
- Pupillary status isn't reliable.
- Dose: 2-4 mg IV; Every 10-15 minutes till Atropinization.
- Oximes (PAM) act at Nicotinic sites along with decreasing muscarinic and CNS symptoms.
- MOA- Oximes remove the phosphate group.
- Pyridoxine decreases the requirement of Atropine and so potentiates the action of atropine.



Postmortem Findings

- Signs of Asphyxia
- Congestion of all organs.
- Pulmonary edema
- Blood-stained froth is seen at the mouth and nose (seen in Organophosphorus).
- Kerosene smell due to Aromax (solvent present in pesticides).
- Organophosphorus can be detected in a putrefied body.

prince kumar
princeeeekum@gmail.com
9928609733

00:20:45

Carbamates

- Reversibly inhibit carboxylic esterase enzymes (AchE) by carbamylation.
- Spontaneously hydrolysed from an enzymatic site within 48 hrs.
- Cannot penetrate CNS.
- Atropine is a specific antidote.
- Oximes are contraindicated.
- Examples- Aldicarb, D-carb, Propoxur, Baygon, Ficam.

Organochlorine

- Ex- Aldrin, Endrin, DDT
- Deposited in fat.
- Endrin is also known as Plant Penicillin & inhibits Gaba Mediated Cl- influx in CNS.
 - Excitatory effect overall
- Endrin is a CNS Stimulant
- Symptoms include Tremors, Myoclonus, and seizure.
- Hyperthermia, mydriasis, and respiratory failure are also seen.

Management

- Resuscitative measures along with gastric lavage activated charcoal.
- No specific Antidote.
- Symptomatic treatment.

Kepona Shake - Tremors of Head, Hand

- Tremor of chronic Organochlorine. Ex- Chlordecone which causes Kepona Shake

Pyrethroids

- Here, we use Mosquito repellents.
- MOA- Inhibits Sodium channel.
- Supportive treatment.

Aluminum Phosphide (ALP)

- Also, known as Celphos.
- Used as a grain preservative having a Garlicky smell / Odor.
- Each 3gm tablet liberates 1 gm of phosphine gas.

- Phosphine has cytotoxic Action by inhibiting an enzyme which is Cytochrome oxidase.
- The chemical reaction is accelerated by HCL presence in the stomach.
 - Fatal dose- 1-3 tablets.
- Liver shows Centrizonal Hemorrhagic Necrosis.
- M/c cause of death is Cardiogenic shock.
- Mortality= 35-100% (high).
- No specific Antidote is given.
- Magnesium Sulfate is given to correct Hypomagnesemia, Arrhythmia.
- Activated charcoal & Liquid Paraffin is used to decrease absorption and increased excretion respectively.

Zinc Phosphide

- Can be used as a Rodenticide.
- Causes slow releases of Phosphine.
- Onset is low.
- Garlic / rotten fish smell.

Inorganic Irritant-Nonmetallic Poison

00:32:00

Phosphorus Poison

- It is a protoplasmic poison.
- Also known as Diwali Poison.

	White	Red
Toxic	Yes	Non
Odor	Garlicky	No
Luminous	Yes	Non
Morphology	Crystalline	No
Inflammable	Yes	Non
Kept underwater	Yes	No

- White+red phosphorous (some)=Yellow Phosphorus (Poisonous)

Use of Red Phosphorus

- For making matchboxes
 - Glass particle + Red phosphorus
- Matchstick
 - Sulfur + (potassium chlorate)

White Phosphorous

- Used in chemical warfare.
- Used for making crackers (mainly)
- Used for making insecticides.
- Used for making Rodenticide.
- In the old time, it was used as Arson for firing the houses or huts.

- For Phosphorous the antidote is CuSO_4 (poisonous)
- Asterixis (tremor).
- Vit. k is used in the treatment.
- Smoking stool syndrome.



- It is a phosphorus burn (high chances when used as crackers)
- Irritant poison leading to Gastroenteritis.
- Accidental Poisoning is very common in children.
- Fatal dose- 60-120 mg.
- Fatal period- 2-8 days.

3 Stages of Phosphorus intoxication

- First stage:
 - Burning pain in Throat, Stomach, and Abdomen
 - Nausea, vomiting, pain, Diarrhea
 - Seen in 1-2 days of Poisoning.
 - Fatty changes or failure of the liver may be seen.
 - Yellow atrophy of the liver can also be seen.
 - Painful penetrating burn (2nd & 3rd degree).
 - Breath and excreta have a Garlicky odor or smell.
 - Luminous vomiting and faeces are diagnostic.
 - Smoking stool syndrome- white faint fumes coming from stool or faeces.
- Second stage:
 - Asymptomatic
 - Can last for 3-4 days.
- Third stage:
 - Systemic
 - Multi-organ failure.
 - Liver & RBC involved.
 - Flapping Tremor (Asterixis).
 - Kidney failure.
 - Encephalopathy.
 - Jaundice.

Treatment

- Gastric Lavage with KMNO_4 .
- Antidote is CuSO_4 (not used for oral as it's poisonous).
- Vit K is used for treatment.
- FFP is used for treatment.
- Burn should be washed with 1% CuSO_4 .

PM finding

- Garlicky Odor.
- Jaundice.
- PM staining is Dark or chocolate brown P-A-N.
- Yellow liver atrophy.
- Multiple Hemorrhages in mucosa and organ.

Chronic Poisoning

- Common in the matchbox industry while vapor inhalation.
- It causes osteonecrosis of jaw bone
- Phossy jaw or Glass jaw or Lucifer's jaw.
 - It's chronic phosphorus poisoning or osteomyelitis of the jawbone.
 - Symptoms-
 - Tooth in the hold.
 - Pain in the tooth.
 - Swelling in the tooth.
 - Osteonecrosis of the jaw.
 - Multiple discharging sinus.

Inorganic Irritant- Metallic Poison

Copper Poisoning

- Pure copper is not poisonous.
- CuSO_4 aka blue vitriol is poisonous.

C.SO_4

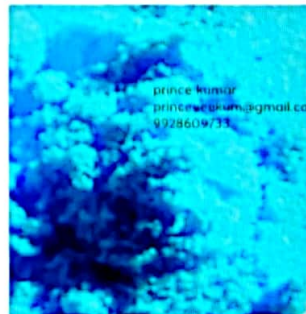

- Copper subacetate / Verdigris
 - Fatal dose- 15gm
- Copper Arsenite → Scheele's Green.
- Copper aceto-arsenite → Paris Green.

Signs and symptoms

- Most of the time, poisoning is accidental.
- Pain in the Throat, Abdomen
- Ptyalism (increased salivation).
- Vomiting (bluish green).
- Hemolysis in RBC, liver, and kidney.
- Chalcosis (Copper depositions in tissue)
 - Chalcosis oculi (Copper deposition in eye)
 - Defective copper metabolism is Wilson Disease (autosomal recessive disease)-sunflower cataract-KF ring is seen in Descemet layer.

- Clapton Lines (Green color lines in gums because of Copper sulfide)
- Hair becomes green.
- Vineyard sprayer's lung disease-
 - It was noticed in Portuguese.
 - Causes interstitial Pulmonary fibrosis.
 - Granuloma is seen in the lung.
 - Exposure of Cuso₄ in vineyards.

prince kumar
princeekum@gmail.com
9928609733

Treatment

- Gastric lavage with 1%.
- Chelating agent of choice which is D-Penicillamine.
- 1% Potassium Ferrocyanide is also used.

Thallium Poisoning (ideal homicidal poison)

- Alopecia is seen after 1-2 weeks of exposure.
- Painful Polyneuropathy resembles GBS.
- Skin rash (Maculopapular rash)- distribution is in a butterfly pattern.
- Sign de sourcil → Lateral 2/3rd of eyebrow are lost.
- Mee's line is also seen.
- Antidote used is Prussian Blue.

Cadmium Poisoning

- Very common in battery, welding industries, water, and contaminated food, smoking.
- Replaces calcium of body → Hypocalcemia → weak, brittle bones & Fracture.
- Spine and leg pain
- Gait waddling
- Disease is known as Ouch-Ouch disease or Itai-itai disease.
- Can have PCR necrosis.
- Hair becomes yellowish color.
- Teeth become yellow.
- Chelating agent of choice is DMSA.

Manganese Poisoning

- Features look like Parkinson's Disease.
- Metal fume fever or Smelter fever.
- Inhalation of some metal fumes (Ex- zinc, nickel, copper, antimony, lead, iron, cobalt).
- Symptoms resemble → malaria.
- Symptoms start in 6-8 hrs.
- Symptoms subside in 36 hrs.

Mercury Poisoning

- Also known as Quicksilver
- Hg is used for Mercury.
- Minimata disease, Mercuria-Lentis
- Erethism (psychiatric problem).

01.04.18

- Danberry Tremor (starting).
- Acrodynia
- Chronic mercury Poisoning is known as Hg:
 - Hydra Gyrism
 - Also, known as Hatter Shake.
 - Common in the glass industry and hence known as Glass Blower Shake.

Mercury

- Elemental mercury (thermometer) is not poisonous because it is not absorbed from the GI tract.
- A liquid metal
- Mercuric Compounds are more poisonous than Mercurous compounds
- Acute exposure to elemental mercury vapor is very common among Glass Industry workers.
- Mercuric salt (poisonous) is known as Mercuric chloride or corrosive sublimate.
- Donovan's Solutions used for SDT is a combination of mercury and Arsenic.
- Toxicity → organic mercury (methyl, ethyl) > mercuric salt > Mercurous salt (Mercurous sulfide- Caromal)
- Mercuric sulfide is used in Sindoor in vermilion.
- Lead tetroxide is another poison.
- Mercuric thiocyanate is used for making crackers known as Pharaoh Serpent

Symptoms of Acute Poisoning

- Acrid metallic taste, the feeling of constriction in the throat, difficulty in breathing.
- Corrosive lesions in mouth and tongue showing grayish-white coating.
- Diphtheria-like colitis (diphtheric colitis) & if the patient survives for 1-3 days → PCT, Gingivitis, and membranous colitis is seen.
- Treatment:
 - Gastric lavage with 5% Sodium Formaldehyde Sulfoxylate and Sodium bicarbonate.
 - Sodium Formaldehyde Sulfoxylate is the antidote.
 - Chelating Agent of choice is BAL.

Chronic Poisoning Mercury

- Chronic poisoning Mercury → Hydra-Gyrism
 - Gingivostomatitis, Erethism, Tremors
- M-Minimata → Seen in Japan (selfish)
 - Disease-Organic (Methyl) Mercury
- E-Erethism (Mad Hatter Syndrome) → Shy depression, Anxiety Loss of confidence, Suicidal
- Danberry Tremor- Coarse, Hand, Lips, Tongue, (Earliest-Worse)
- HG- Hatter's



- Shake (Not able to Dress, Walk)
- Glass-Blower Shake
- Conussio Mercurialis- Most Severe- Bedridden, No Activity seen
- Mercuria lentis → Hg = Anterior lens capsule → brown color
 - Reflex → Slit examination → Brown malt reflex is seen
 - Visual Acuity → Intact
 - B/L
- Acrodynia → also know as pink disease, swift disease caromel ds
 - Puffy-hands & feet
 - Painful
 - Pinkish
 - Pruritus, Perspiration-sweating is seen
 - Peeling of skin, Resemble Kawasaki disease

prince kumar
princeeeekum@gmail.com
9928609733



CROSS WORD PUZZLES



Crossword Puzzle

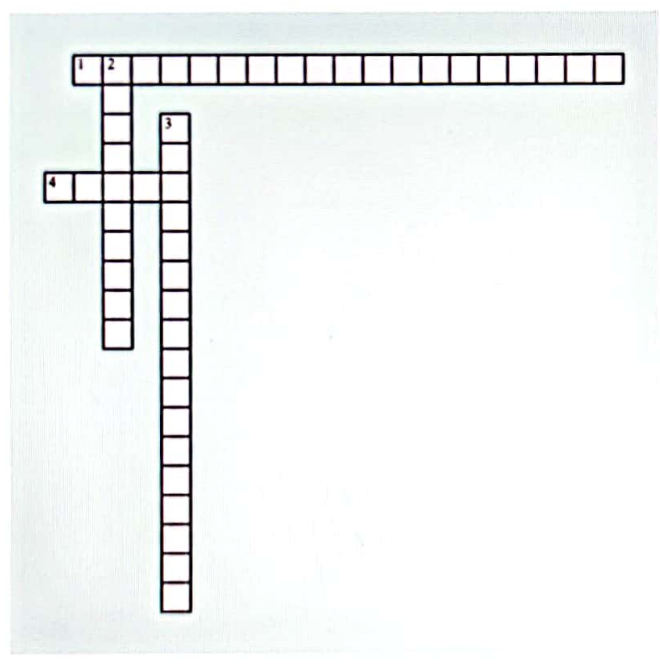

Across

- 1. gastric lavage
- 4. used for aconite

Down

- 2. used for strychnine
- 3. Black color



22

GENERAL TOXICOLOGY PART - 3 (STARVATION DEATH, ASPHYXIAN POISON, AND MISCELLANEOUS LAWS)



Starvation

- Withholding of food and water or administration of unsuitable food leads to starvation.
- **Baby farmer:** Term used to describe any child who is starved by their parents



Causes

- Age.
 - Child starvation occurs in battered baby syndrome
 - Starvation of the elderly occurs in abuse.
- Sex.
 - Female starvation due to sexual discrimination.
- Trapped.
 - Being trapped in pits, mines, or landfills.
 - Accidental starvation.
- Neglect.
 - May be of children, adults, or the elderly.
- Religious.
 - Religious starvation occurs through mandatory fasting.
- Hunger strike.

Medicolegal aspect

- Accident starvation – most common.
- Suicidal starvation.
- Homicidal starvation.
 - Battered baby syndrome.
 - Elderly abuse.

Fatal starvation

- Death usually occurs when 20% of total body protein is lost.
- 40% of the original weight is reached.
- 70-90% of body fat is lost.

Fatal period

- If completely withdrawn from both food and water → Death in 10-12 days.
- If only food is withdrawn → Death in 6-8 weeks.
- Newborns may survive for 7-10 days without food and water.

Postmortem findings

- Extreme emaciation and the general reduction in size and weight of all organs, except the brain.
- Gall bladder is distended with bile.
- Brown atrophy of the heart.
- Rigor mortis sets in and disappears early.
- Face is pale with inelastic and pigmented skin.
- Ankle edema.
- Fat is completely absent in subcutaneous tissue sparing the female breast and orbit.
- Stress fracture due to demineralization and osteomalacia.
- Wall of the intestine appears like tissue paper with atrophy of mucosa and all layers are also bile stained.

Asphyxiant

00:06:43

Gases that cause asphyxia

- Carbon monoxide.
- Cyanide.
- Hydrogen sulphide.

Carbon monoxide (CO)

- Colorless.
- Odorless.
- Lighter than oxygen.
- No irritation.
- 40x more affinity for myoglobin than oxygen.
- 210x (200-300x) more affinity for hemoglobin than oxygen.
- Shift the oxygen dissociation curve to the left side.
- Anemic anoxia or anemic hypoxia.
- Anaerobic metabolism leads to lactic acid formation and high anion gap metabolic acidosis.

CO poisoning

- May be accidental or suicidal.
- Accidental reasons:
 - Car engine.
 - Chimney.
 - Heater, especially gasoline.



CO poisoning symptoms

- CO automatism.
 - Erratic movements of the dying victim inside the room, disturbing clothing and furniture which indicate a violent struggle.
- Upper limit of safety is 0.01% CO in the air.

CO concentration	Symptom
10-20%	<ul style="list-style-type: none"> • Headache. • Muscle weakness.
20-30%	<ul style="list-style-type: none"> • Throbbing headache. • Dyspnea. • Emotional irritability
30-40%	<ul style="list-style-type: none"> • Dizziness. • Disorientation. • Judgmental impairment.
40-50%	<ul style="list-style-type: none"> • Similar to alcoholic drunkenness'. • Ataxia. • Hallucination. • Disorientation. • Slurred speech.
50-60%	<ul style="list-style-type: none"> • Syncope. • Coma. • Convulsion. • Myocardial infarction. • Arrhythmia.
60-70%	<ul style="list-style-type: none"> • Coma. • Death.
>70%	<ul style="list-style-type: none"> • Death.

CO poisoning treatment

- 100% high-flow oxygen until carboxyhemoglobin falls to 15-20%.
- Hyperbaric oxygen.
 - Barotrauma is a side effect.



Important Information

Rebound toxicity of CO

- Oxygen exposure to carboxyhemoglobin (CO-Hb) leads to CO binding with myoglobin.
- CO diffusion into the blood at a later stage leads to the reformation of Co-Hb.

CO poisoning tests

- Hoppes-Seyler's test.
- Kunkel test.
- Spectroscopy.
- Wetzel test.
 - Discontinued.

PM findings in CO poisoning

- Cherry-red post-mortem staining.
- Blisters in dependent or frictional areas.
 - Axilla, buttocks, inner thigh, calves, wrists, and knees.
 - Also seen in barbiturates poisoning.
- Bilateral and symmetrical necrosis and cavitation.
 - Seen in globus pallidus and putamen i.e., basal ganglia change.

Cyanide

- Produced in apple, apricot, peach, plum, almond, and linseed.
- Liquid cyanide → Hydrocyanic acid or Prussic acid.
- 4% cyanide in water → Scheele's acid.
- Gas → Cyanogen or Hydrogen cyanide.
- Bitter almond smell.
 - Smell perception is a sex-linked recessive trait.
- Ideal for suicidal poisoning.
- Salts such as KCN and NaCN are non-toxic.
 - Combine with hydrochloric acid in the stomach to form HCN that is absorbed.
- No effect in achlorhydric individuals.

Mechanism of action

- Has an affinity for ferric ions Fe^{3+} .
- Binds with cytochrome C oxidase (complex IV of electron transport chain).
- Cell cannot utilize oxygen leading to histotoxic/cytotoxic anoxia.
- Anaerobic metabolism leads to lactic acid formation and high anion gap metabolic acidosis.

Cyanide poisoning signs and symptoms

- Inhalation → Dizziness, vertigo, and constriction of the throat.
- Ingestion → Nausea, headache, loss of muscular power, hypotension, cardiovascular failure, and convulsion.
- Death occurs from respiratory failure.

Uses of cyanide

- Electroplating.
- Fumigation.
- Goldsmith.
- Photography.

Cyanide poisoning treatment

- Remove the exposure source and clothes (avoid absorption through the skin).
- Vitamin B12 → Best antidote.
 - Hydroxocobalamin combines with cyanide to form CN-cobalamin that is excreted.
- ELI-LILLY antidote.
 - Triple antidote.
- Amyl Nitrite inhalation.

- IV Sodium nitrite.
- Sodium thiosulphate is 50%.
- Sodium bicarbonate.
 - Correction of acidosis.
 - IV methylene blue used in severe conditions.
 - Para-aminopropiophenone (PAPP) can also be used.



Important Information

Amyl Nitrite, sodium nitrite, and 50% sodium thiosulphate

- Conversion of hemoglobin to methemoglobin that combines with cyanide to form cyanmethemoglobin.
- Sodium thiosulphate combines with cyanmethemoglobin to form water-soluble thiocyanate that is excreted in the urine.

prince kumar
princekumar@gmail.com
9928609333

Post-mortem findings

- Brick-red or bright red staining.
- Bitter almond smell.

Cyanide poisoning test

- Lee-Jones test.

Hydrogen sulphide

- Formed during the decomposition of organic substances containing sulphur.
- Rotten egg smell.
- Knock-down gas → Sudden loss of consciousness.
- Also known as sewer gas.
- Detergent suicide phenomenon is seen in Japan.
 - Bath salt containing sulphur combined with toilet bowl cleaner containing hydrochloric acid.

Management

- Hyperbaric oxygen and nitrites → Antidote.



Important Information

- Hydrogen sulphide acts on **Cytochrome C oxidase** (Complex IV of electron transport chain).

Miscellaneous laws

00:30:51

Juvenile Justice Act

- Any child < 18 years.
- Age decided by birth certificate, physical appearance, and medical examination.
- Functions:
 - Punishment for cruelty against a child.
 - Juvenile justice board formed to deal with juveniles who have committed crimes.
 - 3 members of the juvenile justice board:
 - 1st class judicial magistrate.
 - 2 social workers (one should be female).

Punishment of juveniles

- Normal offense → < 3 years in a juvenile home or rehabilitation center.
- Serious crimes → 3-7 years.
- Heinous crimes → > 7 years.
- Children between 16-18 years who have committed a heinous crime e.g., rape or murder will be sent for psychiatric assessment and trialed as an adult.
- Other orders:
 - Counselling.
 - Fines.
 - Special homes.
 - Community service.

Consumer Protection Act 2019

- Amendment made in 2019, with the original proposed in 1986.
- Came into action on 20th July 2020.

Redressal Commission

- District → 1 crore compensation.
- State → 1-10 crores.
- National → > 10 crores.
- Appeal in Supreme Court.

Time limitation

- Case should be filed within 2 years.
- Appeal heard within 45 days (after district).
- Next appeal is heard within 30 days (after state).
- Case completion time – 3 months.
- Case completion time if there are any lab tests – 5 months.
- Appeal completion – 90 days.

Important features

- E-filing of complaints.
- E-commerce sites included.
- Misleading advertisement.
- Forum conversion to the commission.
- Time limitation increased from 30 days to 45 days.
- Central consumer protection authority established.

Rights of consumer

- Information.
- Protection.
- Assurance.
- Heard.
- Awareness.
- Redressal.

Protection of Children from sexual offense (POSCO) act-2012

- Last amendment in 2019.
- Applicable for ages < 18 years.
- Evidence of the child to be recorded within a period of 30 days and completion of trial within a period of one year, as soon as possible.

Sexual harassment

- Bullying or coercion of a sexual nature and the unwelcome or inappropriate promise of rewards in exchange for sexual favors.
- Includes:
 - Sound and gesture, and exhibiting an object.
 - Child pornography or showing child pornography.
 - Making the child exhibit a body part or showing his body part.

Sexual assault

- Act in which a person intentionally:
 - Sexually touches another person without their consent.
 - Coerces or physically forces a person to engage in a sexual act against their will.
- No penetration.
- Hormone administration.

Penetrative sexual assault

- Penetrate the penis into any orifices of a child or any object into the:
 - Vagina, urethra, or anus.
 - Applies mouth (body part) to the penis, vagina, urethra, or anus of a child.

Aggravated penetrated sexual assault.

- Sexual assault by:
 - Two or more than two people.
 - Relatives.
 - Age of child < 12 years.
 - Armed forces.
 - Insane/Institutionalized child.
 - Trusted or having authority.
 - Officer
 - Repeat offender.
- Done by:
 - Police officer.
 - Armed/Security forces.
 - Public servant.
 - Management/Staff of jail, remand home, protection home.
 - Hospital staff.
 - Staff of educational or religious institutes.
 - Gang.
- Involves:
 - Using deadly weapons.
 - Causing grievous hurt.
 - Making a child mentally ill or pregnant or HIV positive.
 - Act done on disabled children or pregnant children.
 - With an attempt to murder or during communal violence.
 - By guardian, repeatedly on the same child.
 - Child aged < 12 years.

POSCO offenses and punishment

Offense	Punishment (POSCO-2012)	Punishment (POSCO-2019)
Penetrative sexual assault	7 years to life imprisonment plus a fine.	If a child is below 16 years, 20 years to a life term plus fine.
Aggravated penetrative sexual assault	10 years to life imprisonment plus a fine.	20 years to the death penalty plus a fine. It adds two more grounds to the list for aggravated sexual assault. <ul style="list-style-type: none"> • Assault resulting in the death of a child. • During natural calamity.
Sexual assault without penetration	3-5 years imprisonment plus a fine.	Same.
Aggravated sexual assault without penetration	5-7 years imprisonment plus a fine.	Adds two more offenses: <ul style="list-style-type: none"> • During natural calamities. • Administering any chemicals or hormones for cervical maturity.
Sexual harassment	0-3 years imprisonment plus a fine.	Same.
Use of child for pornographic purposes	0-5 years imprisonment (7 years for subsequent offense) plus a fine.	Minimum 5 years imprisonment.
Storage of children for pornography	0-3 years plus fine.	Adds two more offenses: <ul style="list-style-type: none"> • Failure to destroy or delete such. • Mode for transmitting.

Human organ transplantation act (HOTA-1994)

- Transplantation of human organs and tissues act (THOTA-2014).
- Deals with removal, storage, and transplantation.
- Prevent commercial dealing.
- Human organ definition.
 - Any part of the human body (structured arrangement of tissue) that, if removed, cannot be replicated in the body.

Brain stem death declaration by doctor

- Can be done by:
 - Treating a doctor.
 - In-charge doctor.
 - Neurologist or neurosurgeon.
 - Intensivist, anesthetist, or physician.
 - Independent specialist authorized by the government.

Checklist for brain death

	CN	Center
Light reflex	2,3	MB
Vestibulo-ocular	3,6,8	MB/P
Dolls eye	3,6,8	MB/P
Corneal	5,7	P
GAG	9,10	Medulla
Apnoeic	Respiratory center	Medulla

- MB-midbrain, P- pons.

Donations type

Living donation.

- Near relatives i.e., parents, son, daughter, brother, sister, grandparents, and grandchildren.
- Non-relatives → Prior approval from any authorized committee.
- Swap transplantation between unmatched pairs.

Cadaveric donation.

- Authorized by:
 - Any donor above 18 years and of sound mind.
- Will written before death instructing for transplantation in the presence of two witnesses.
- Consent needed for legal possession of body given:
 - If there was no will.
 - Unknown dead body for more than 48 hours done by doctor or in-charge.
 - In medicolegal case requires approval from the autopsy surgeon.

Most commonly donated organs

- Heart.
- Liver.
- Thymus.
- Intestine.
- Lungs.
- Kidney.
- Pancreas.

- Most common: Kidney > Liver > Heart.

Most commonly donated tissues

- Bone.
- Cartilage.
- Cornea.
- Middle ear.
- Veins.
- Valves.
- Skin, tendon, and ligament.
- Most common: Cornea > Bone > Tendon.

Punishment

Human organ/tissue transplantation without authorization

- 10 years plus 20 Lakhs fine.
- Applicable for medical staff and paramedical staff.

Additional punishment for the doctor

- The State medical council nullifies registration.
- 1st offense → 3 years.
- Subsequent offense → Penal erasure or professional death sentence.

For commercial dealing

- 2-7 years plus a fine.

Medical certification of cause of death (MCCD)

00:59:19

- MCCD issued by a doctor.
- Death certificate issued by the registrar or sub-registrar of state government.
- Doctor's duty in MCCD:
 - Diagnose the person as dead.
 - Declare death.
 - Conclude the cause of death.
 - Certify the cause of death.

Cause of death

- Reason someone dies.
- Underlying/Primary cause.
 - Disease or injury that initiated events.
 - Example: Diabetes mellitus.

Antecedent/Intermediate cause. (Part-1)

- Occurs sometime between primary and immediate causes.
- Example: Gangrene.
- Immediate cause.
 - Final complication due to disease or injury.
 - Most recent event that occurred before death.
 - Example: Septicemia.
- Diabetes mellitus (primary cause) → Gangrene (intermediate cause) → Septicemia (immediate cause).
- Underlying/Primary cause written in mortality statistics.

FORM NO. 4A
(See Rule 7)

MEDICAL CERTIFICATE OF CAUSE OF DEATH
(For non-institutional deaths. Not to be used for still births)
To be sent to Registrar along with Form No. 2 (Death Report)

I hereby certify that the deceased Shri/Sm/.Km..... son of/wife of/daughter of resident of was under my treatment fromto and he/she died on at AM/PM.

NAME OF DECEASED					For use of Statistical Office
Sex	Age at Death				
	Age in completed years	If less than 1 year age in months	If less than one month age in Days	If less than one day, age in Hours	
1. Male 2. Female					
CAUSE OF DEATH				Interval between on set & death approx.	
I Immediate cause State the disease, injury or complication which caused death, not the mode of dying such as heart failure, asthenia etc.		(a)			
	 Due to (or as a consequences of)			
Antecedent cause Morbid conditions, if any, giving rise to the above Cause, stating underlying condition last		(b)			
	 Due to (or as a consequences of)			
II Other significant conditions contributing to the death but not related to the disease or conditions causing II		©			
				
If deceased was a female, was pregnancy the death associated with? 1. Yes 2. No					
If yes, was there a delivery? 1. Yes 2. No					

prince kumar
princeekum@gmail.com
9928609733

Cause of death		Approximate interval between onset and death
I Disease or condition directly leading to death* <i>Antecedent causes</i> Morbid conditions, if any, giving rise to the above cause, stating the underlying condition last	(a)
	due to (or as a consequence of)	
	(b)
	due to (or as a consequence of)	
	(c)
	due to (or as a consequence of)	
	(d)
<hr/> II Other significant conditions contributing to the death, but not related to the disease or condition causing it	
	
<i>*This does not mean the mode of dying, e.g. heart failure, respiratory failure. It means the disease, injury, or complication that caused death.</i>		

Contributory conditions (Part II)

- Not related to disease but contributed to the death.
- Unfavorable conditions.

174(3) CRPC

- Police inquest.
- Police are unable to identify the cause of death and refer to the doctor to conduct a postmortem.



Important Information

Example

- A. Rupture of the myocardium – immediate cause.
- B. Myocardial infarction.
- C. Coronary artery thrombosis.
- D. Atherosclerosis.
- Part II-Smoking, Chronic obstructive pulmonary disease (COPD), Diabetes mellitus.

MCCD (4A) and Death report (2)

- MCCD form 4A.
- Death report form 2.
- Both forms are sent to the registrar or sub-registrar of the state government to assign a death certificate within 21 days.
- If a patient is already dead when they are brought to the hospital, only form 2 is sent and the doctor informs the police.
 - Post-mortem is conducted to determine the cause of death.
 - No form 4A.

RBD ACT-10(3)

- Registration of Birth and death act.
- Obligatory for registered medical practitioners (RMP) who attended a patient's last illness.
- No fee charged for the cause of death.
- Cause of death given instantly.
- Certification of cause done by RMP.



CROSS WORD PUZZLES



prince kumar
princeeeekum@gmail.com
9928609733

Crossword Puzzle

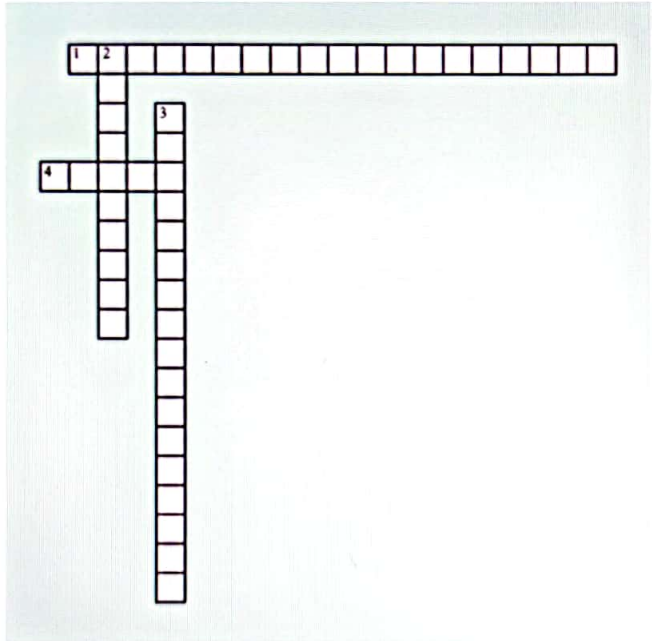

Across

- 1. gastric lavage
- 4. used for aconite

Down

- 2. used for strychnine
- 3. Black color

23

ANIMAL IRRITANT POISON



prince kumar
princeeeekum@gmail.com
8609733

Blister Beetle (BB)

- If consumed, causes **Cantharide poisoning**.
- AKA Spanish fly



- **Active principle: Cantharidin**
 - 1 beetle contains 0.2-0.7 mg of cantharidin.
 - Indian flies contain 3% of cantharidin.
- Locally produces painful blisters.
- **Oral intake: Increases libido.**
 - Aphrodisiac
- **Causes priapism:** Painful erection of the penis.
- **Fatal dose:** 15-30mg of cantharidin
- Cantharidin is nephrotoxic.
 - Can cause chronic renal failure.
 - Have symptoms of **uremia**.

Scorpion Buthidae (Venomous Arachnids)

- C from scorpion and B for family
- Arachnids mean has 8 legs (Spider also)
- Mechanism of Action: C from scorpion
 - Uncontrolled release of Catecholamine.
 - It affects the sodium-potassium channel.
- Toxins
 - Neurotoxin
 - Hemotoxin
 - Resembles spider and cobra. The amount is less so not fatal.
- Types of Buthidae
 - Black
 - Indian red scorpion (**Mesobuthus tamulus**)
- Causes autonomic storm.
 - **Local symptoms**
 - Intense pain
 - Swelling
 - Blisters
 - **Other symptoms**
 - Sweating palpitation
 - chest pain
 - Mydriasis
 - **PRIAPISM**

- **Treatment**
 - Immobilization
 - Pain (NSAID)
 - Asv (Anti Scorpion Venom)
 - **Alpha Blocker (Prazosin)**

Spider (Venomous Arachnids)

- **Toxin: Neurotoxin**
 - Locally Necrotic
 - Excitatory Neurotoxin
- **Most poisonous spider: Black widow**
- **Treatment**
 - Antihistamines
 - If infection Antibiotics
 - D of spider: Dapsone

Snake Study

00:09:05

- **Study of the snake poison: Ophiology**
- Types of study
 - **Viperidae: (True viper)** Russel's viper, saw-scaled viper.
 - V for viper, V for **Vasculotoxic**
 - **Elapidae: Cobra and Krait (Common)**
 - Co for Cobra
 - Co for Common Krait
 - **Neurotoxic**
 - **Hydrophidae: Sea snakes**
 - Act on skeletal muscles.
 - Myotoxic



Important Information

Five Dangerous and Poisonous Snakes in India

- **Cobra**
 - Fatal dose: 12 mg
 - **Common Krait**
 - Fatal dose: 6 mg
 - **Russell Viper**
 - Fatal dose: 15mg
 - **Saw Scaled Viper**
 - Fatal dose: 8 mg
 - Echis: E for 8 mg
 - **King Cobra**
 - Fatal dose: 12 mg (But more amount)
- Most dangerous snake is the king cobra.
 - One bite amount is **200-250 mg** venom (Cobra)
 - It is more in King cobra.
 - Most poisonous snake: Krait

Differences between Poisonous and Non-Poisonous Snake

Feature	Poisonous	Non-Poisonous
Head scale	Small	Large
Belly Scale	Large Covers the entire breadth of the belly	Small
Tail	Compressed	Not compressed
Fangs (Teeth)	Like a hypodermic needle	Multiple teeth
Bite mark	2 bite mark	Multiple bite mark
Habit	Nocturnal	Diurnal

Exception of Head scale

- 2 poisonous snakes with large head scale
 - **Cobra:** C is 3rd in alphabet. 3rd Supra-Labial is large and touches the eye shield.
 - **Common Krait:** 4th Infra-labial is Large and touches the eye shield.

King Cobra and Cobra



Differences between Cobra and King Cobra

	King Cobra	Cobra
Name	Ophiophagus-Hannah	Naja Naja
Length	15-20 ft (Longest)	5ft
Hood	Present	Present but large
Spectacle/Binocellate mark	Absent	Present
Inject venom	More	Less

- Spit cobra: Spits venom
- If spits in the eye cause **ophthalmia**.

Krait

- Bungarus caeruleus
- Hexagonal Scale with white band.
- Toxin: Bungarotoxin

Common Krait



Russell's Viper

- Daboia Russeli
- **Venom:** Vasculotoxic

Russel Viper-three rows of brown spots



Important Information

- Brown spots are diamond shape.
- One row on top and 2 rows on the lateral part.

Saw Scaled Viper

- Echis carinatus
- **Venom:** Vasculotoxic

Saw Scaled Viper-angulated scale, coiled around



- Angular scale
- Coiled around giving a rustling sound.

Hump Nosed viper

- Hypnale Hypnale
- H = Hump
- Snout form hump



Hump Nose Viper-Hypnale Hypnale



Important Information

- **Envenomation:** Local symptom and other symptoms study is known as Ophiotoxemia

Sea Snake

Sea Snake-Flat Tail (padding)



- Flat tail (Padding)
- Skeletal muscle

Python

- **Nonpoisonous**
- Cause traumatic **Asphyxia by encircling**.

Gland and Fangs

- Gland for poison
- Fang is teeth - **Maxillary teeth**.
- Glands are modified salivary glands.
- Salivary gland duct opens in teeth.
- Whenever it bites, poison goes through the body through skin puncture.
- If you drink the venom, it is not poisonous.
- Ulcer in GI tract: There is an effect.

Signs and Symptoms

- **Most common symptom: Fright** (A most common cause of death)
 - Anxiety
 - Chest pain
 - Palpitation
- 70-80% are non-venomous snakes.
- 20% of venomous snakes are dry bite.
 - Dry bite was most commonly seen in cobra.
- **Snake bite venom Injection: Clinical spectrum**

- **Local**
 - Pain
 - Swelling
 - Blisters
 - Bleeding (**Characteristic**)
 - Necrosis
 - Regional Lymphadenopathy (**Characteristic**)
- **ASV (Anti Snake Venom)** should be started if.
 - Painful swelling
 - Bleeding
 - Lymphadenopathy
- Local symptoms are maximum with viper.
- Local symptoms are less with krait.
 - No bite marks.
 - No symptoms.

Signs and Symptoms of Neurotoxic snakes (Elapidae)

- **Ptois:** Most Important and Common Symptom.
 - Dropping of Eyelid
- **Diplopia:** Paralysis of extra ocular Muscles.
- **Dysphagia:** Paralysis of pharyngeal muscles.
- **Dysphonia:** Paralysis of vocal codes.
- **Dysarthria:** Paralysis of tongue muscles.
- **Dyspnea:** Paralysis of respiratory muscles.
- **Stridor:** Respiratory difficulty.
- **Descending Paralysis**
- Death due to respiratory muscles paralysis leading to respiratory failure.
- **Treatment**
 - Mechanical ventilation
 - ASV
 - Neostigmine (**with a combo of Atropine**)
- Neuroparalytic Symptom without Local Finding
 - Mechanical Ventilation
 - ASV

prince kumar
princeekum@gmail.com
9928609733



Important Information

- **Single Breath Count Test: Elapid**
- Count the numbers in a single breath.
- Every 15 minutes
- If decreases that suggest that respiratory failure taking place.

Sign and Symptoms of Vasculotoxic (Viper)

- **DIC: Disseminated Intravascular Coagulopathy**
- Local and systemic bleeding



- Epistaxis, hematemesis, melena, gum bleeding (common bleeding)
 - Pain swelling
- **Renal Failure:** Due To DIC
- **If Abdominal Pain-Retroperitoneal Bleeding.**
 - Suggests Viper Bite
- **Treatment**
 - Start With ASV
 - FFP (Fresh Frozen Plasma)
 - Surgical Debridement

- Crepe bandage
- Sutherland Wrap
 - Motive is to occlude lymphatic.
 - Venom passes through the lymphatic
- **Upper Limb pressure:** 40-70 mmHg
- **Lower Limb pressure:** 55-70 mmHg
- Done in cobra bite.
- Not done in viper bite, Because it can cause compartment syndrome

Vasculotoxic Test

00:37:15

- 20 Minute whole blood clotting test
- **Steps**

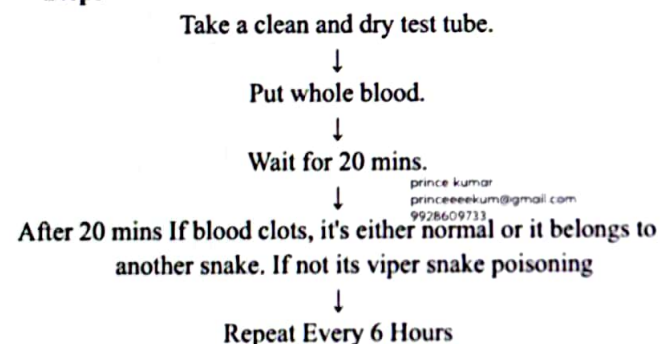

Sign and Symptoms of Myotoxic

Local-Pain

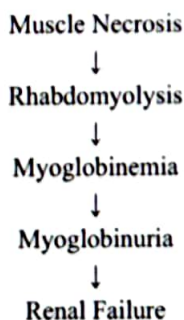

- **Treatment**
 - Follow the **RIGHT** strategy.
 - R: Reassure
 - I: Immobilization
 - GH: Go to Hospital
 - T: Tell all history and Symptoms to the doctor.
 - **NO:** Mistakes to avoid
 - Suction
 - Ligature
 - Tourniquet
 - Cautery
 - Electricity/electric shock
 - Immobilize limb by

Important Information

- **ASV Route:** IV
- **Rate:** 1-2 mL/kg
- **Doses:** 8-10 vials

ASV

00:43:20

- **Frozen or dried powder:** Use some diluent.
- Discovered by Calmette
- **Institute in India:** Haffkins institute
- **Four Snakes**
 - Cobra
 - Krait
 - Russell Viper
 - Saw scaled viper.
- **Should be within 4-5 hours** of the bite.
- **Source:** Horse Hyperimmunized serum.
- **Can lead:** Allergies/Anaphylaxis
- **Get ready with Adrenaline** to counteract any allergies.
- **Given when.**
 - **Severe local:** Pain progressive swelling with bleeding.
 - **Severe systemic:** Bleeding in the System, Neurotoxic, Abnormal whole blood clotting.
- **Neuroparalytic symptom:** Till clinical improvement
- **Vasculotoxic symptom:** Till clotting time become normal.

Other Treatment

- **Neostigmine:** 1.5mg
 - Anticholinesterase (increase the acute-cholinergic effect).
 - Reduce Respiratory failure.
 - **Action:** Post synaptic toxin action as in cobra
- **Atropine:** 0.6mg
 - To control the muscarinic effect of anti-cholinesterase
- **Antibiotics and tetnus toxoid:** For infection
- **ASV + Neostigmine + Atropine + Mechanical ventilation:** For cobra bite.
- **ASV, FFP, and surgical debridement:** Done in viper bite
- **ASV + Mechanical ventilation:** Krait
- **Krait Venom:** Presynaptic action



CROSS WORD PUZZLES



Crossword Puzzle

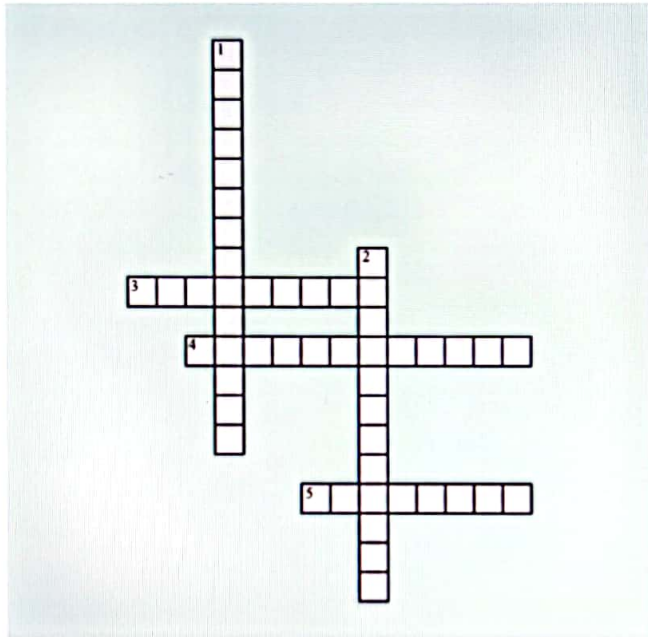

Across

- 3. Snake Study
- 4. Active principle
- 5. Painful erection of penis

Down

- 1. Vasculotoxic
- 2. Sea snakes



- They cause burns.
- Corrosives are two types.
 - Acids
 - Alkali
- Acids cause coagulative necrosis.
 - Eschar/Crest is formed.
 - Decrease in deep penetration.
- Alkalis cause liquefactive necrosis.
 - It is more dangerous.



Important Information

- Only acid that leads to liquefactive necrosis is Hydrofluoric acid (HF)

Corrosives Poisoning Laws

- 326(A) IPC - Acid attack
- 326(B) IPC - Acid attack **attempt**
- 357 CrPC - Any hospital should provide first aid treatment for Rape/Vitriolage (Poisoning).
- 166 B IPC - **Noncompliance with 357 CrPC** will be punishable under this section.
- 154(1) CrPC - FIR should be filed for Rape/Vitriolage cases.
- 166 A IPC - If an **FIR is not filed**, the investigating officer will be punished under this section.

Classification of Corrosives

00:04:01

Acids

- **Inorganic acid**
 - Causes local damage
 - **Examples:** HCl, H₂SO₄, HNO₃
- **Organic acid**
 - Leads to local and systemic damage.
 - **Examples:** Acetic acid, Boric acid, Carbolic acid, Oxalic acid.

Alkali

- Cause liquefactive necrosis.
- **Examples:** NaOH, KOH, and Carbonates.
- NaOH is also called **LYE**



Important Information

- Esophageal stricture is more predominant in Alkali Poisoning than Acid Poisoning.
- Alkalis are the most common cause of chemical burns.

Corrosive Poisoning Management

00:05:55

- **Airway, Breathing, and Circulation (ABC)** stabilization
- Gastric lavage is **Contraindicated**.
 - As it may cause perforation
 - **Exception:** For Carbolic acid, gastric lavage can be performed.
- Emetics are **Contraindicated**.
 - They may cause Aspiration pneumonia.
- Alkaline Carbonate **cannot be given**.
 - Gas will be produced as a result of an acid and alkali combination leading to gastric dilation and rupture.
- Demulcent
 - Starch and milk can act as demulcents
- Diluent
 - Water is used as diluent.
- Diluent and Demulcents are given cautiously as they may induce vomiting
- For pain relief
 - NSAIDS
- Steroids
- IV fluids for shock management
- Symptomatic treatment.

Sulphuric Acid Poisoning

00:08:00

- H₂SO₄ is also called Oil of Vitriol
- It is colorless, odorless and hygroscopic (absorbs atmospheric moisture).
- Carbonization is observed in tissues
 - Black/ Charred tissues

Signs and Symptoms

- Skin
 - Becomes dark brown/black.
- Mouth
 - Burning pain
 - Black coloration of tongue
 - **Teeth become chalky white.**
- Pharyngeal pain
- Larynx
 - Edema
 - Stridor
- Esophagus
 - **Odynophagia:** Pain during swallowing
- Stomach
 - Wet Blotting paper mucosa: black/brown coloration of stomach mucosa.



Important Information

- **Fatal dose:** 5-10 ml
- **Fatal period:** 15/18-24 hours

- Circulatory collapse may lead to shock.
- Perforations can lead to peritonitis.
- Edema of the Larynx

Postmortem Findings

- Teeth are chalky white.
- Tongue is black.
- Stomach mucosa is white (**wet blotting paper mucosa**)
- Laryngeal edema
- **Magenstrasse**
 - Street of stomach
 - Acid pathway is seen on the lesser curvature of the stomach.
- **Vitriolage skin burn**
 - It is painless.
 - Contracture is seen at the burn (**Eschar**).
 - No vesicles.
 - Treatment
 - Wash with water.
 - Topical magnesium oxide or sodium bicarbonate.
- **Eye burn**
 - Wash with water.
 - Topical sodium bicarbonate
 - Olive oil

Nitric Acid Poisoning

00:15:27

- It is also called **aqua fortis**
- **Xanthoproteic reaction:** Tissue becomes the yellow formation of picric acid.
- Skin, Teeth, and Stomach mucosa become yellow.
- Sometimes, the stomach mucosa is also brown.

Oxalic Acid Poisoning

- Also called as **Acid of sugar/ Salt of sorrel**
- It is seen in cabbage, spinach, tomato, lady finger, rhubarb.
- It is generally used as a stain/Ink remover.

Signs and Symptoms

- Burning throat pain
- Coffee ground vomitus: Blood gets mixed with acid due to shredded stomach mucosa
- Systemically, calcium oxalates are formed.
 - Hypocalcemia is observed.
- **Oxaluria:** Oxalate crystals in the urine
- Chronic renal failure/ Uremia
 - Due to Oxalate deposition in renal tubules

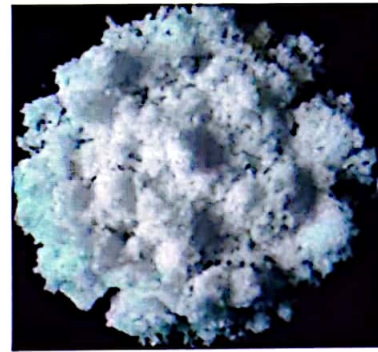

Mnemonic: C C C C C C

- **C**, seen in **Cabbages**.
- **C**, **Calcium oxalate** is formed.
- **C**, **hypo Calcemia**
- **C**, the antidote is **Calcium gluconate/Lactate** or chalk powder or wall scrap.
- **C**, **Coffee ground vomitus**.
- **C**, **Calcium oxalate** deposition leading to **Chronic renal failure**.
- Signs of hypocalcemia and tetany are present.



Important Information

- **Fatal dose:** 15-20 gram
- **Fatal period:** 1-2 hours

Treatment

- Gastric lavage **can be done** with Calcium Lactate
- Antidote is **Calcium gluconate/ Calcium lactate**.
- **Oral calcium gluconate**
- **IV 10% Calcium gluconate**
- Hemodialysis in case of renal failure.

Carbolic Acid

- Also termed **phenol**.
- It is a disinfectant or antiseptic.
- Generally, it is colorless.
- But when exposed to air it becomes pink-colored needle-shaped crystals.

prince kumar 00:22:38
princeeeekum@gmail.com
9928609733



Important Information

- **Fatal dose:** 1-2 gram
- **Fatal period:** 3-4 hours

Mnemonic: P P H P P P (Phenol)

- **P**ink on-air exposure
- **M**etabolites are **P**yrocatechol and **H**ydroquinone.
- **P**henolic **M**arasmus - **C**hronic **P**oisoning of **P**henol.
- **R**esist **P**utrefaction
- **P**CT (proximal convoluted tubule) necrosis.

Telegram - @nextprepladdernotes

- Mnemonic: CCCC (Carbolic acid)
 - Constriction of the pupil
 - Deposition of Pyrocatechol and Hydroquinone in Cartilage and Cornea (Ochronosis)
 - Carboluria
 - Urine color changes from green to dark.
 - Carbolism
 - Acute carbolic acid poisoning
- Carbolic acid causes Leathery mucosa.
 - Hence gastric lavage can be performed.



- Phenolic products are:
 - Thymol
 - Lysol
 - Cresol
 - Resorcinol

Acute Carbolic Acid Poisoning

- Also called **Carbolism**
- Signs and symptoms
 - Skin
 - Painless burn
 - Numbness
 - White Eschar
 - Stomach
 - Leathery mucosa
 - Thus, gastric lavage is done.
 - CNS
 - Carbolic acid is CNS depressant.
 - CVS
 - Hypotension
 - Pupils
 - Constriction (**Miosis**)
 - Hemolysis of RBC
 - Methemoglobinemia
 - PCT necrosis

princeeeekum@gmail.com
9928609744

Chronic Carbolic Acid Poisoning

- Also called **Phenolic Marasmus**.
- Signs and symptoms
 - Anorexia
 - Weight loss
 - Dark urine
 - Skin Pigmentation
 - Ochronosis (deposition of Pyrocatechol and Hydroquinone in Cornea and Cartilage)

Management

- For skin burn - Topical Polyethylene glycol.
- Gastric lavage with **castor or olive oil**.
- Treatment for shock
- Hemodialysis

Boric acid Poisoning

- It causes a **Boiled Lobster syndrome**.
- Erythema formation and desquamation of skin.

Hydrofluoric Acid Poisoning

- H⁺ ion and F⁻ ions are formed
- H⁺ ion causes **coagulative necrosis**.
- F⁻ ion causes **liquefactive necrosis**.
- HF forms insoluble salts with calcium and magnesium.
 - With **Calcium** causes **hypocalcemia**
 - With **Magnesium** causes **hypomagnesemia**
 - Hyperkalemia can also be seen (leading to cardiac arrhythmias).

Signs and Symptoms

- Skin
 - **Burning sensation**
- On ingestion
 - Burning pain
 - Hematemesis
 - Pain and cough
- **Metabolic acidosis**



Important Information

- Hypocalcemia is caused by Oxalic acid, Ethylene glycol, and Hydrofluoric acid

Treatment

- Antidote is **Calcium gluconate**.
- Correction of hypocalcemia, hypomagnesemia, and hyperkalemia.



CROSS WORD PUZZLES



Crossword Puzzle

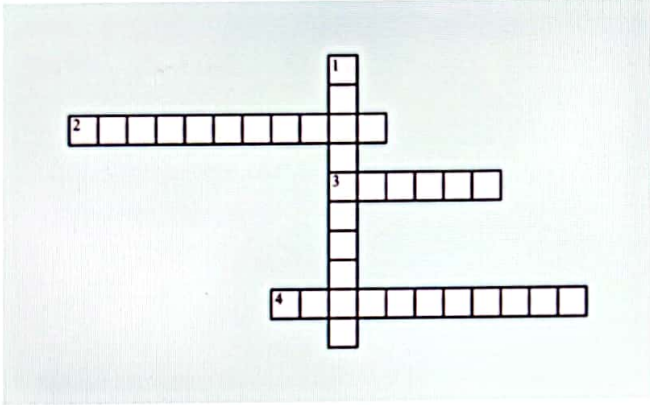

Across

- 2. Pain during swallowing
- 3. NaOH
- 4. Inorganic acid

Down

- 1. 326(A) IPC

25

SPINAL CARDIAC POISON



Spinal Poisons

1. Strychnine Poisoning

- Caused by Strychnine derived from *Strychnos nux vomica* (Kuchila)
 - It is used to kill stray dogs, hence called **Dog-buttons**.
 - Seeds shape is concavo-convex.
 - It is odorless and bitter in taste.
 - **Fatal dose:** One crushed seed
 - Tests to identify Strychnine is.
 - Wenzel test
 - Sonenshein test
 - Strychnine is excitatory in action.



Important Information

- Wenzel test is used in case of Carbon monoxide (CO) Poisoning

Strychnine Seeds aka Dog Buttons



Active Principles

- **Strychnine:** It is a more potent than one
- **Brucine:** These two are alkaloids
- **Loganin:** It is a glucoside.

Mechanism of Action

- Acts on the anterior horn cell of the spinal cord (**Renshaw cells**)
- Complete blockade of the Ventral horn of motor neurons and postganglionic receptor site.
- Effects of glycine (**inhibitory neurotransmitter**) are inhibited in the spinal cord and brainstem.
 - Thus, the overall effect is excitatory.
 - Thus, this disease mimics the disease of Tetanus.

Two phases are present

- **Convulsion**
 - Convulsion phase is increased in this poisoning.
 - There may be 5-6 convulsions simultaneously.
 - Clonic convulsions are seen.
- **Relaxation**
 - Normally duration of the relaxation phase is **more** compared to the convulsion phase.
 - But in this poisoning, the convulsion phase is elevated.
- Cause of death is respiratory muscle spasm - **Asphyxia**.
- Consciousness will be retained.

Differentiation between Tetanus and Strychnine poisoning

- In Strychnine Poisoning
 - **All muscles are affected at the same time.**
 - External stimuli increase the convulsions.
- In tetanus, there will be **sequential muscle spasms**.

Clinical Features

- **Tonus**
 - Opisthotonus
 - Hyperextension of back.
 - Most characteristic feature.
 - Emprosthotonus
 - Hyperflexion of back.
 - Pleurothotonus
 - Lateral bending
- **Spasm**
 - Risus Sadonicus
 - Spasm of facial muscles.

Tests

- Wenzel test
- Sonneschin test

Treatment

- Avoid gastric lavage as there will be convulsions. (**Gastric lavage is Contraindicated in Convulsions**).
- Controlling seizures
- Keeping patients away from convulsion-triggering stimuli
- Acidification of the urine
- Antidote (**to control seizures**)
 - Phenobarbitone
 - Diazepam

Postmortem Findings

- Rigor mortis
 - **Mnemonic:** ST Ea L

- ST-Strychnine, Ea- Early, L- Long duration
- Early in onset and long duration
- Postmortem Caloricity
 - Body temperature increases after death due to increased muscle action.
- Putrefaction
 - Rate of putrefaction is decreased.
- Brain and spinal cord are to be **preserved**.



Important Information

Rate of putrefaction is decreased in

- **Mnemonic: SMC**
 - Strychnine
 - Metallic poisoning
 - Carbolic acid, Carbon monoxide, and Cyanide poisoning

2. Gelsemium Poisoning

- It is inhibitory in action.

Cardiac Poisons

00:12:56

Mnemonic: Queen DONAC

- **Caused by**
 - Quinine
 - Digitalis
 - Oleander (yellow, white/pink)
 - Nicotina tabacum
 - Aconite
 - Cerebra odellum

1. Aconite Poisoning

- It is also called blue rocket/ monks hood/ **meetha zeher**

Aconite (Blue Rocket)



- Roots are conical in shape and tapered at the end with longitudinal ridges.
- **All parts are poisonous.**
- Roots and seeds are the most poisonous part.
- Roots of Aconite are generally **mistaken as Horseradish root**

Active Principles

- Aconitine
- Pseudoaconitine
- Aconin

Mechanism of Action

- Mainly acts on sodium channel (**AcoNite, Na⁺ channel action**).
- Binds to voltage-dependent sodium channels and prolongs the action leading to
 - Excitation of sensory nerves
 - Sensory nerves are predominantly affected than motor nerves.
 - Paralyze the motor ganglia of the heart.
 - Respiratory center is slowed.
 - Tachycardia followed by Bradycardia is observed.
- Cause of death is due to Cardiac arrhythmia (mostly Ventricular arrhythmia)
- **Hyperkalemia** is also seen.

Signs and Symptoms

- Tingling and numbness of mouth and throat (**most characteristic symptom**)
- **Sweet taste**
- Numbness and paraneesthesia of face, perioral area, and progress to all over the body.
- Weakness of four limbs
- Twitching of muscles
- **Hippus sign:** Alternate contraction and dilation of the pupil.
- **Xanthopsia:** Visual illusion of yellow color around objects.
- Hypotension, bradycardia, ventricular ectopic, cardiac arrhythmia with AV block

Fatal Dose: 1-2 gms of the root is fatal.

Treatment

- Gastric lavage with warm saline.
- **Atropine for AV block.**
- Supportive treatment
- Correction of hyperkalemia

Medicolegal Importance

- Accidental poisoning by **horseradish root**
- One of the ideal homicidal poisonings.
- It mimics natural cardiac arrhythmia.
- Destroyed by putrefaction.

2. Oleander Poisoning

A. Yellow Oleander

- Also called **Cerebra Thevetia** or **peela kaner**.
- All parts of the plant are poisonous.
- **Active Principles**
 - Cerebrin
 - Thevetoxin A and B
 - Nerifolin

Peela kaner

**B. Pink Oleander**

- It is termed as **Nerium odorum** or **white oleander**.

Pink Oleander-Oleandrin, Nerin, Foli AKA



- **Active Principles**
 - Oleandrin
 - Nerin
 - Folinerin
 - Rosagenin

Mechanism of Action of Oleander poisoning

- Action is like digitalis.
- **Inhibition of Sodium-Potassium ATPase channel** leading to
 - Brady/Tachycardia
 - AV block
 - Hyperkalemia

Treatment of Oleander Poisoning

- Gastric lavage with **warm saline**
- **Antidote:** Digibind (same as that of Digitalis)
 - Digibind binds to the Fab end of the antibody.

- **For AV block - Atropine**
 - **For hyperkalemia - Dextrose and Insulin**
- 3. Digitalis Poisoning**
- Digitalis purpurea is also called purple Fox glove.

Digitalis Purpurea

**Mechanism of action**

- **Inhibition of Sodium-potassium ATPase channel**

Treatment

- Treatment is **same as Oleander poisoning**.

4. Cerebra Odallam

- Also called are **Suicidal tree**.

Active Principles

- Cerberin
- Cerebroside
- Odollin
- Odollotoxin

Treatment

- **BHIST regime**

5. Nicotine

- Most common substance abuse in India

**Important Information**

- Most common illicit substance in India is Cannabis



CROSS WORD PUZZLES

Crossword Puzzle

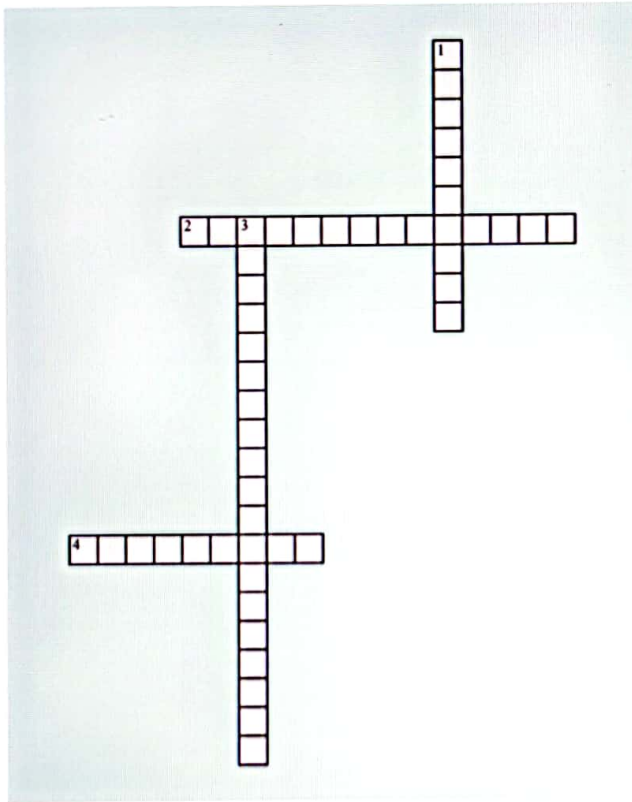

Across

- 2. spasms
- 4. One crushed seed

Down

- 1. Active Principles
- 3. Strychnos nuxvomica



Opium

- Sleep-causing poison.
- **Opium:** Afim, Kasoomba, Madak
- From fruit known as **Papaver Somniferum**
- Afim extracted from unripe fruit and given vertical incision.

Poppy Fruit



- If these poppy fruits become **blue or greenish color**, we give vertical incision.
- Milky juice (Latex) is extracted
- When latex becomes dry, it becomes a brown or dark color
- It is known as **crude opium**.
- Poppy seeds are known as Khas Khas
- It is used for cooking sweets, sharbat etc

Poppy Seed



- Poppy seeds are nontoxic.
- Derivatives
 - **Natural (MTC):** morphine, thebaine and codeine
 - **Semi-synthetic:** Heroin
 - **Synthetic (m):** Methadone
- **Mechanism of action:** Acts with the release of endorphin.
- Opium depresses all centers except vomiting, sweating, and ocular centers.

Fatal Dose

- **Morphine:** 100 mg
- **Methadone:** 0.2 g
- **Codeine:** 1/2 g
- **Opium:** 2g (**Comes under NDPS act**)
 - Cultivation of opium is **allowed in Rajasthan, UP, and MP**

Stages

- **Excitement:** Euphoria
- **Stupor:** Drowsiness, constriction of the pupil, and cyanosis.
- **Coma**
 - Hypothermia
 - Respiratory depression
 - Typical pin-point pupil
 - All secretions are suspended except for sweating.



Important Information

Classical Triad (CRP)

- Coma
- Respiratory depression
- Pinpoint pupil

Tests (MDH)

- **M -** Marquis test
- **D -** Deninges test
- **H -** Husemann test

Morphine

00:08:15

- — Miosis
- **O -** Orthostatic Hypotension
- **R -** Respiratory Depression
- **P -** Pain Relief (**Painkiller used in Cancer**)
- **H -** Histamine Release (Bronchospasm), **HYPOTHERMIA**
- **I -** Increased ICT, **INFREQUENCY** in GI tract. (Constipation)
- **N -** Nausea, **NALOXONE** (Antidote)
- **E -** Euphoria
- **S -** Sedation

Treatment

- Gastric lavage with **KMnO₄**,
- Done even if taken by parenteral route/IV route
 - **Reason:** Morphine goes into enterohepatic circulation and is ultimately secreted in the GI tract.
 - Same with cocaine, amphetamine, and barbiturates.
- **Antidote:** Naloxone, Naltrexone (**Oral**)
- **Postmortem finding:** Signs of asphyxia
 - **Froth:** Mouth and nostrils.
- **PM staining:** Blackened
- **Organs:** Congested

Chronic Poisoning (Morphinism, Morphinomania)

- Opium addicts can tolerate 3 to 6 gm per day.
- Morphinism is the **increase of dose** and being able to tolerate it.
- Withdrawl effect -**SECRETIONS (increased)**- Piloerection, Mydriasis, and Rhinorrhea

**Important Information****Withdrawal Effect**

- Yawning
- Insomnia
- Dysphoric mood
- Dehydration
- Increased BP
- Heart rate
- Respiration

Heroin: Semi Synthetic

00:14:06

- Junk , Dope , Smack , Brown Sugar
- Di Acetyl morphine
- **Fatal dose: 50 mg**
- **Cutting in** is the Adulteration of heroin
 - Quinine
 - Fructose
 - Chalk powder
 - Mannitol
- **Speedball: Heroin + Cocaine**
 - If smoked this condition is known as Moon Rock.
 - **IIS:** Hotshot is strychnine

prince kumar
princeeeekum@gmail.com
9928609733

- **Heroin:** Pure and refine
 - Comes with salt heroin hydrochloride.
 - Taken in injection form.
- **Brown sugar:** Less refine and not pure.
 - Black tar present (**Not pure**)
 - Can be smoked or sniffed.
 - Not given by IV route because it causes **Thrombosis sclerosis**.
 - **Most common method: Chasing the dragon (Smoking)**
 - Take aluminum foil, add brown sugar and heat below and smoked/sniffed.
- IV and skin-popping is done for Heroin hydrochloride.

**Heroin Treatment**

- **Antidote: Naloxone**
- **Shooting the gallery:** Place where heroin sold

Brown sugar

Heroin





CROSS WORD PUZZLES



Crossword Puzzle

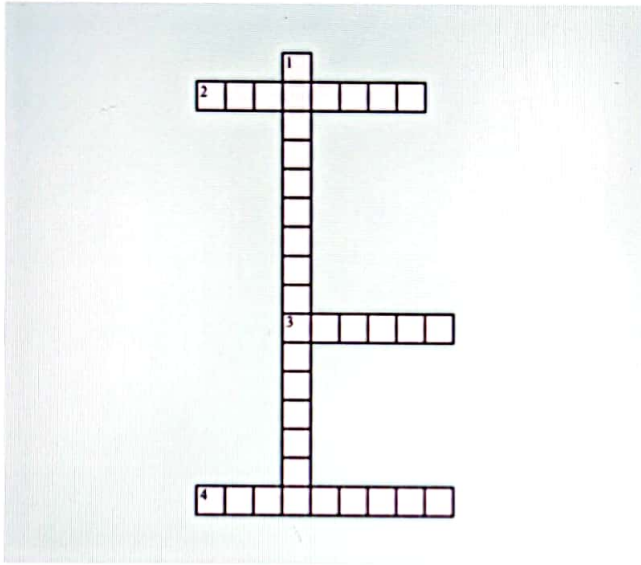

Across

- 2. Antidote
- 3. Semi Synthetic
- 4. Heroin+Cocaine

Down

- 1. Natural (MTC)

prince kumar
 princeeeeekum@gmail.com
 9928609711



Ricinus Communis

- AKA Castor plant or Arandi
- **Fatal dose:** 10 seeds
- **Entire plant is poisonous.**
- **Main toxalbumen:** Ricin
- **Mechanism of action of toxalbumen:** Inhibits RNA polymerase
- **Overall effect:** Protein synthesis inhibition
- **Toxalbumen Definition:** Just like a bacterial toxin that causes RBC agglutination
- **Potency:** 6000 times > Cyanide poison.
- **Signs and symptoms**
 - Burning pain
 - Abdominal pain
 - Bloody diarrhea
- **Biological warfare:** Category B

Ricinus Communis



- Small shiny seeds with yellow or white marking

Croton Tiglium

- AKA Jamalgota or Napala
- **Fatal dose:** 5 seeds
- **Active principle:** Crotin
- **Entire plant is poisonous.**
- **Signs and symptoms**
 - Burning pain
 - Abdominal pain
 - Bloody and intense diarrhea
 - **Strong purgative**

Croton Tiglium/ Napala



Abrus Precatorius

- **Most important active principle:** Abrin, Abralin, Abralic acid
- Abrin is like viper venom.
- AKA Ratti, Gunja, Gunchi, Rosary Bead, Jequirity, Indian Liquor rice

Ratti Seeds



- Red seed with black tip
- It is an animal poison.
- **Arrow poison**
- **Signs and symptoms**
 - Local necrosis of Abrin
 - Systemic manifestation
- Needle or Sui is prepared from crushed seeds which are used to throw at cattle. It is considered **ideal cattle poison.**
- Size of the needle or Sui is around 15mm.
- **Fatal dose:** Around 1-2 seeds
- **Treatment:** Gastric Lavage
- **Injection:** Anti Abrin
- Dissection of either sui or needle

Semicarpus Anacardium

00:09:02

- **Heart shape seed**
- AKA Marking Nut, Bhilwa plant.

Semicarpus Anacardium



- **Active principles:** Semicarpol and Bhilawanol
- Pericarp irritant juice turns **black or brown** when in contact with air which is pro-inflammatory.
- **Used for**
 - Making Artificial bruise.
 - Causes the formation of painful blisters on the skin.
 - Marking on clothes
- **Fatal dose:** 5-10g
- **Orally** - GI symptoms

Calotropis Gigantea / Procera / Rubber Bush

- **Active principle:** Calotropin, Calotoxin, Calactin, Gigantean, Uscharin
- AKA Akdo or Madar
- **2 species of Calotropis**
 - Calotropis Gigantea - Purple color flower
 - Calotropis Procera - White color flower
- Calotropis is AKA **rubber bush**.

Calotropis



- Artificial poison
- Artificial bruise
- Cattle poison
- Can cause conjunctivitis, which can be used as a **malingerer**.
- Dilated pupil.
- Convulsion

Capsicum Annuum - Chilli

- AKA **Mirchi**
- **Active principle:** Capsacin, Capsicin
- **Odor and taste:** Pungent
- **Seeds resemble Datura.**
- Cross section of seed gives a figure of 6 appearance
- Painful contact dermatitis (**known as Hunan Hand**)
- Used for torture and robbery.
- Can cause conjunctivitis.

Chilli Seeds



Deliriant Poison

00:17:18

- Poison that causes delirium
 - Cannabis
 - Cocaine
 - Datura

1. Datura/ Devil's Trumpet

- If it is a white flower plant, it is Datura Alba
- If it is a purple dark color flower it is Datura Niger
- Datura Stramonium AKA Jimson's weed is also known as thorn apple.

Datura Stramonium



Seeds

- **Entire plant is poisonous.**
- **Active principle:** Hyoscine (Scopolamine), Truth serum drug, which is used in narco analysis, Hyoscymine, Atropine
- 1 Fruit almost contains 100s of seeds.
- **Fatal dose is 100- 125 seeds.**



Important Information

9928609733

- 1 fruit can kill 4-5 people

Datura Alba



- Used as a roadside poison or railway poison.
- There is no criminal responsibility for a person who has been given Datura because his actions are involuntary intoxication.
- **328 IPC** - Hurt with poison with criminal intention.
- Maximum punishment is up to 10 years.
- Anticholinergic
- **Signs and Symptoms**
 - Dryness in skin and mouth
 - Dysphagia - Difficulty in swallowing
 - Dilated pupil (**very earliest symptom**)
 - Drunken Gait
 - Dysarthria - Slurred speech
 - Muttering Delirium
 - Drowsiness
 - Death
 - **Carphologia**-It feels like it is a kind of hallucination, imaginary threads, and pill-rolling movement.
 - **Feature**
 - Blind as a bat
 - Hot as a hare
 - Dry as a bone
 - Red as a beet
 - Mad as a hen

Corn picker's Pupil

- Unilateral mydriasis. If you stay on a farm and datura pollen goes to your eyes
- **Mydriatic test**
 - Not used now
 - Using the urine of the patient and putting in the eyes of rabbit that causes mydriasis.
- **Treatment**
 - Stomach wash and activated charcoal.
 - **Physostigmine** is the antidote choice for datura used to counteract the anticholinergic action.
 - Short-acting barbiturates to **control delirium**.

MLI: Medico Legal Importance

- Stupefying agent
- It can be used as a Love philter.
- Accidental poisoning. It looks like a chili seed



Datura Seed vs Chili Seed

	Datura	Chili
Color	Dark Brown	Yellow
Shape	Kidney shape	Round shape
Consistency	Thick	Thin
Surface	Not smooth	Smooth
Odor	Odorless	Pungent smell
Taste	Bitter	Pungent
Cut-Section embryo	Curved outward	Curved inward

2. Cannabis

- **Species**
 - Cannabis Indica
 - Cannabis Sativa
- Most common illicit drug abuse.
- It is Illegal (planting, carrying, etc..).
- It comes under the **NDPS act**.
- **Active Principle:** 9 Tetrahydrocannabinol
- More potent: Leaves and flowers
- Male and female plants are separate.
- Street names of cannabis: Marijuana, weed, hemp, grass, rope, hash.



• Bhang/Siddhi or Sabji

- It is legal.
- Prepared from **dried leaves** of the cannabis plant.
- Active principle is **<15%**
- Sweet product of Bhang is majoon (Bhang+Honey+ any edible oil like ghee)

• Ganja

- Active principle is about **15-20%**
- **Flowering top of the female plant**
- Reefer/ Joint cigarette.
- Hukka. A combination of ganja with tobacco

• Charas

- Aka Hashish
- It is a **resin of the plant**.

- Active principle is about 25-40%
- Oil of it is known as **Hash oil** (the active principle is 70 to 90%)
- **More potent:** Hash oil > Charas

Fatal Dose

- 2g for Charas
- 8g for Ganja
- 10g for Bhang
- **Sinsemilla**
 - **Not a preparation of India**
 - Unpollinated or Seedless dried flower of female plant

Effects of Cannabis

Effects of Cannabis	
Small Doses	High Doses
Causes euphoria which is excessive happiness	Psychiatric problems: Euphoria, hallucination, increase self-confidence,
Disorientation Time: Temporal	● Increase appetite and thirst.
Space: Spacial	● Increase the time of coitus.
Disorientation	● Gynecomastia

Chronic Effects of Cannabis

- Cannabis causes degeneration of the CNS.
- Chronic cannabis poisoning
 - **Hashish insanity:** Hallucinations
 - Auditory
 - Visual
 - Delusion of persecution
- **Run amok:** A person goes into depression and then there is a homicidal tendency and then depression leading to suicidal tendencies.
- **84 IPC:** Unsound mind where you are not liable for the crime.
- **Amotivational syndrome:** Frustrated, lack of confidence
- **Flashback phenomena:** Most commonly seen in LSD. (Re-experience of past experience)
- **Intermittent vomiting:** Hyperemesis Syndrome
- **KORO**
 - **In males:** Penis shrink in size.
 - **In females:** Breasts shrink in size.

 **Important Information**

- Smell of cannabis is burnt rope smell.
- Diazepam is used to treat cannabis

3. Cocaine

- AKA Snow/ white lady/ she
- **Other names**
 - Coke
 - Crack

- Prepared from cocca leaves.
- Plant is known as *Erythroxylum cocca*.
- It causes **vasoconstrictor**.
- It has an **Alkaloid**.
- Salt of cocaine is in powder form which is known as cocaine hydrochloride which is taken as an injection.
- Crack is smoked. It is cocaine + baking soda.
- **Cocaine Route**
 - Snorting
 - Smoking
 - IV
 - Oral route
- **Mechanism of action:** Inhibits the synaptic reuptake of Epinephrine, Norepinephrine, Dopamine, Serotonin.
- All these substances will **increase synaptic cleft**.
- This will cause Sympathomimetic Toxidrome.

Sympathomimetic Toxidrome Complications		
	Small Dose	High Dose
Heart Rate	Increase	Cardiac arrhythmia
Blood vessels	Constrictive	Myocardial Infarction
Blood Pressure	Increase	Intracerebral brain stroke
Respiratory rate	Increase	Increase
Temperature	Increase	Crack fever
Sweating	Increase	Increase
Pupil	Dilated	Fixed
CNS Effects	Excitation Euphoria	Delirium Excitation

Chronic Cocaine Abuse

- AKA Cocainism, Cocainomania or Cocainophagia
- **Tolerance for high doses**
- Rush (When excited) and crash (when depressed)
- **Triad of cocaine abuse**
 - Nasal/ Palatal perforation
 - Black tongue and teeth
 - Gangrene of periphery (Nose tip, ear lobule)
- Cocaine bugs is aka **Magnan symptom** or formication.
 - This is tactile hallucination. It seems like insects, mice or rats are crawling on skin.

Treatment

- **Antidote:** Amyl nitrite to control heart rate and BP
- Supportive and Symptomatic treatment
- **Fatal dose:** Around 1g.

 **Important Information**

- **Crack house:** Place where crack is sold.
- **Shooting the gallery:** Place where heroine is sold.
- **Speed ball:** Cocaine + Heroine



CROSS WORD PUZZLES



Crossword Puzzle

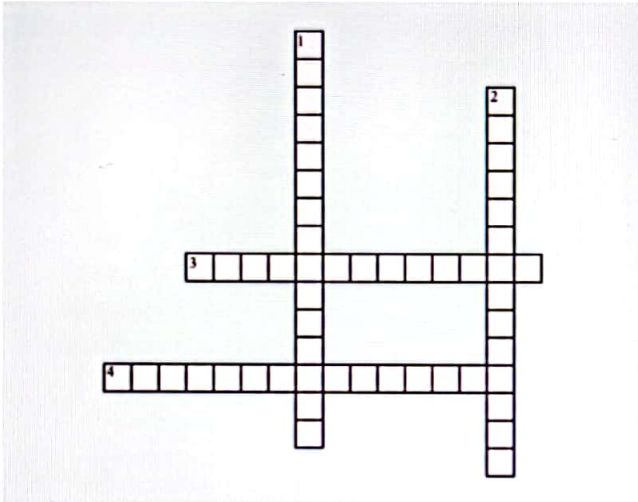

Across

- 3. Jamalgota
- 4. Cannabis

Down

- 1. Castorplant
- 2. Chilli

prince kumar
princeeeekum@gmail.com
9928609733

28

METAL POISONS, MISCELLANEOUS POISONS, AND CNS DEPRESSANT



Arsenic Poisoning

Mnemonic

- **A**
 - Aldrich-Mees line/ Reynold's line (present over nails)
 - Aphrodisiac (increase libido)
- **R**
 - Red velvety mucosa
 - Raindrop pigmentation
 - Rashes (fading measles rash)
- **S**
 - Sub endocardial hemorrhage/ Sheehan hemorrhage.
- **E**
 - Excess hyperpigmentation of palms and soles.
- **N**
 - Neuritis (sensory > motor)
- **I**
 - Iron oxide antidote (hydrated ferric oxide)
- **C**
 - Mimics cholera

Poisonous Compounds

- Metallic arsenic is non-poisonous.
- **Poisonous compounds are.**
 - **Arsenic trioxide**
 - Colorless
 - Odourless
 - Tasteless
 - Used as a homicidal poison
 - **Another name:** White arsenic/ Sankhya/ Somalkar
 - Used in AML-3 (acute promyelocytic leukemia)
 - **Copper arsenite**
 - **Other names:** Scheele's Green
 - **Copper acetoarsenite**
 - **Other names:** Paris Green
 - **Arsine**
 - Gas
 - Garlicy smell

Arsenic - MOA

Arsenic + SH (Sulph-Hydryl) group of mitochondrial enzymes

↓
Inhibits respiratory chain

- **Target tissue:** Vascular endothelium.
- **Complications**
 - ↑ permeability of vessels
 - Edema
 - GI hemorrhage

Signs and Symptoms of Acute Arsenic Poisoning

- **Fatal dose:** 100-200 mg / 0.1 to 0.2 gm.
- **Fatal period:** 1-2 days

- **Fulminant type**
 - **Dose ingested:** Massive dose
 - Direct action on heart muscles
 - **Cause of death:** Shock
- **Gastroenteric type**
 - Most common
 - Resembles cholera

Arsenic Poisoning	Cholera
Mnemonic: TVP	Mnemonic: PVT
<ul style="list-style-type: none"> • Throat pain • Vomiting • Purging (loose stools) 	<ul style="list-style-type: none"> • purging • vomiting • throat pain
Tenesmus is +ve	Tenesmus is -ve
Blood or urine sample is used	A stool sample is taken

- **Narcotic form**
 - Giddiness.
 - Formication of muscles.
 - Tenderness of muscles
 - **Gastrointestinal symptoms (few/ absent).**

Tests

- **Performed**
 - Urine sample is best (>50 microns/ 24 hours signifies arsenic poisoning).
 - Blood sample is also taken.
 - Hair, nail, and pubic hair (keratin-containing).
 - Best is pubic hair.
- **Not performed**
 - M - Marsh test
 - R - Reinch test
 - G - Gutzeit test



Important Information

- For metal poisoning
 - NAA - Neutron activation analysis.
 - AAS - Atomic absorption spectroscopy.

Treatment

- Gastric lavage with warm saline
- Freshly prepared hydrated ferric oxide (**chemical antidote**)
- **Oral chelating agents**
 - **Oral - DMSA**
 - **IM - BAL (Dimercaprol).**

Postmortem Findings

- Rigor Mortis (comes late and is long).
- Stomach
 - Red-velvety mucosa (Strawberry)
 - Multiple hemorrhages – Flea-bitten appearance.
 - White particles in the stomach.
- Subendocardial hemorrhage.

Arsenophagist

- Take arsenic as an Aphrodisiac (increase libido).
- Can tolerate up to 300 mg.

Key Points

- Arsenic is a good homicidal poison.
- The only disadvantage is it resists putrefaction.
- Detected in,
 - Hair
 - Nail
 - Bones
- Used as inherit powder.
- Early stage only in,
 - Liver
 - Kidney
 - Spleen
- Doesn't cross BBB

Signs and Symptoms of Chronic Arsenic Poisoning

- Skin
 - The earliest sign is Leucomelanosis at the malar area (depigmentation).
 - Raindrop pigmentation (mimics measles and Addison's disease).
 - Hyperkeratosis of palm and soles (bilateral).
 - Rash (mimics measles).
- Nail - Aldrich-Mees Line



- Also seen in
 - Thallium toxicity
 - Chronic renal failure
 - Chemotherapy
- Transverse lines
- Hair
 - Alopecia

- Neuropathy
 - Sensory >> Motor
 - Resembles GBS
- Blood vessels
 - Occlusions
 - Sclerosis
 - Peripheral gangrene (ischemia) - Blackfoot disease.
- Malignancy
 - Squamous cell carcinoma >> Basal cell carcinoma.
 - Predispose to Bowen disease.

Lead Poisoning

00:19:14

Mnemonic

- A - Anemia
- B - Basophilic stippling, Burtonian line.
- C - Colic and constipation.
- D - Drops (wrist drop).
- E - Encephalopathy, common in toddlers.
- F - Facial pallor (earliest and most consistent sign).
- G - Gout (decreases uric acid excretion).

Poisonous Compounds

- Metallic and salts both are poisonous.
 - Lead acetate (sugar of lead) - most common.
 - Lead Sulfide - Surma (eyeliner), least common.
 - Lead tetroxide (vermillion)-Sindoor (but mercuric sulfide is more).
 - Tetraethyl lead-Encephalopathy (common), used as an anti-knock agent in petrol.
 - Lead carbonate - Seen in paints.

Route

- Inhalation: Most common, pipes, plumbers, and paints (adult).
- Ingestion: Pipes, plumbers, and paints (children).
- Skin: Chemical factories.

Chronic Lead Poisoning/ Plumbism/ Saturnism

- Facial pallor (circum-oral)
 - Cause: Vasospasm
 - Most specific
- Anemia
 - Type: Microcytic-hypochromic.
 - Enzymes inhibited (MCQ)
 - L(F) E - Ferrochelatase
 - A D - Ala dehydratase
 - Coproporphyrinogen oxidase.
 - Blood picture
 - Mnemonic: CAB-MAP
 - Cabot rings in RBCs
 - Microcytic-hypochromic
 - Anisocytosis
 - Poikilocytosis and Polycythemia

- **Basophilic stippling/ Punctate basophilia**
 - Due to the inhibition of enzyme 5-Pyrimidine nucleotidase (PNN)

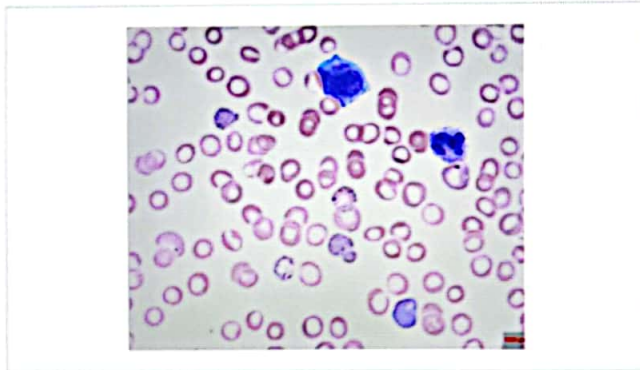

- Accumulation of ribosomes in RBC
- Blue dot in RBCs

prince kumar
princeeeekum@gmail.com
9928609733

- **Lead line**
 - 50-70% of cases
 - Seen in gums.
 - Common in caries teeth (bacteria forms H₂S gas + Lead = Lead sulfide)
 - Takes 1 week to develop.
 - Burtonian lines (blue)



Important Information

- Burtonian lines are also seen in Ag, Bi, Cu, and Fe poisoning.
- Burtonian lines are more specific in lead poisoning



- **Lead osteopathy/ bone-line**
 - Seen among children.
 - Deposition of Ca²⁺ in growing bones
 - Presented as radiopaque band.
 - It takes 4 weeks.
 - Inhibition of osteoclastic activity.



- **Colic and constipation**
 - Late presentation is seen in 85% of cases.
 - Occurs at night.
 - Type of spasmodic pain relieved by pressure.
 - Another name: Painter's Colic/ Devonshir Folic.
- **Lead palsy**
 - Motor >> Sensory
 - Common peroneal nerve - Foot drop
 - Radial nerve - Wrist drop
 - Dry belly ache
 - Less than 10% of cases
- **Encephalopathy**
 - Seen in almost all cases.
 - Associated with tetraethyl lead.
 - Mostly in children
 - 85% have permanent brain damage.
 - 25% of deaths.
- **Reproductive system**
 - Amenorrhea
 - Dysmenorrhea
 - Abortion
 - Sterility
- **Gout**
 - Saturine gout (decreased excretion of uric acid)

Lab Investigation

- **Blood**
 - Blood sample is more important.
 - >5 microgram/ 100 ml means lead exposure.
 - >40 micrograms - signs and symptoms are seen.
 - 35-50 microgram/ 100 ml zinc protoporphyrin.
- **Urine**
 - Urinary ALA (amino levulinic acid) >5 microgram/litre.
 - Urinary coproporphyrin >150 microgram/ litre.
 - Urinary Lead 0.25 milligram/ litre.
- History/ clinical features/ blood picture
- Radiology - Lead osteopathy.

Treatment

- **Lead encephalopathy**
 - BAL + EDTA
 - Adult: >70 microgram/dl
 - Children: >45 microgram/dl
 - BAL
 - Renal failure
 - EDTA is not given, as it leads to the excretion of lead via urine.
 - DMSA (Succimer)
 - Used in children without encephalopathy.
 - Orally given.
 - Removal of exposure
 - Calcium disodium EDTA: >45 microgram/dl.
 - Succimer: 45 to 69 microgram/dl.
 - BAL + EDTA: >70 microgram/dl.



Q. Why is BAL used with EDTA?

Ans: EDTA redistributes Lead to the brain, and BAL prevents this.

Explanation: BAL can cross BBB

Miscellaneous Poisons

00:42:32

1. Hallucinogens

- Leads to hallucinations.

LSD

- LSD-Lysergic acid Diethylamide: Acid blotter or paper stamp
- Taken as fumes
- Obtained from rye fungus (ergot).
- Increases serotonin level in the brain (only psychological dependence).
- Associated with the trip (most common)
 - Good trip
 - Visual hallucinations
 - Illusions
 - Colors
 - Smell
 - Taste
 - Bad trip
 - Anxiety
 - Panic attacks
- Flashback phenomenon is seen (re-experiencing the past experience).

MDMA

- Methylene-dioxy-methamphetamine
- Other name: Ecstasy/ Molly/ Rave drug/ Club drug/ Party drug/ Hug drug
- Causes euphoria.

Love boat

- Cigarette or Tobacco or Marijuana + PCP (Phencyclidine) or Formaldehyde

Phencyclidine

- Other name: Angel Dust

Amphetamine

- Urine can be used as a liquid gold (slang).

Cocaine

- Not actually hallucinogenic
- Causes tactile hallucinations.

2. Chloral Hydrate

- Other name: Dry wine/ Micky- Finn/ Knockout drops
- Colorless crystalline drug
- Given along with alcohol.
- Acrid smell

3. Conium Maculatum

- Other name: Hemlock
- Nerve poison
- All parts of the plant are poisonous.
- Involves motor nerves.
- Used to kill Socrates



Important Information

- It is believed that Arsenic was used to kill Napoleon.
- But later realized that it was Mercury.

- Mousy smell
- Active principle: Conine or methyl conine
- Unripe fruits and seeds are more poisonous.
- 1st involves lower limb muscles (causes lower limb paralysis).
- Death is from respiratory paralysis.
- No specific antidote, only symptomatic treatment.

Contents	Body Packers Syndrome/ Surgical Mules Syndrome	Body Stuffer Syndrome (Hurried)
Introduction of drugs	<ul style="list-style-type: none"> • Planned way. • Polythene or condom • Swallow/ vagina/ rectum 	<ul style="list-style-type: none"> • Unplanned way • Vagina or anal canal • Hurriedly swallowed
Type of conduct	Scheduled	Spontaneous
Packet number	Many	1-2
Risk	Medium or high	High
Other	Used in drug smuggling (good pack)	Damaged or unpacked

Suicide Types

- In India MC is hanging

- **3 types**
 - **Complex:** Attempt more than one method of suicide.
 - **Complicated:** Attempt one method, died due to unintentional trauma.
 - **Para-suicide:** Attempt for suicide, but not to die. The most common type is poison or drug ingestion.
 - It is also known as pseudocide

CNS Depressant - Ethanol

00:57:52

- **Physical characteristics:** Colorless, Transparent, Volatile liquid
- **Toxicity:** Isopropyl alcohol > methanol > Ethanol

Composition of Ethanol in Different Alcohols

- Absolute alcohol - 99.95%
- Rectified spirit - 95% (preserve viscera)
- Denatured/ Methylated spirit - 90% ethanol + 5-10% methanol (wood)
- 100 proof ethanol is 50% ethanol.
- 80 proof ethanol is 40% ethanol.

Pharmacokinetics of Ethanol

- **Absorption**
 - Starts from the mouth.
 - 20% from the stomach.
 - 80% small intestine.
- **Metabolism**
 - Follows zero-order kinetics.
 - Rate of fall 15mg%/1hr.

Factors Affecting Alcohol Absorption

- Increased absorption
 - Empty stomach
 - Carbonated drinks (increases surface area)
 - Warm alcoholic drink.
 - Gastrectomy patients.
- Decreased absorption.
 - Food (protein rich)
 - Ice drink (dilute the proof alcohol)
 - Achlorhydria (less HCl production)
 - Chronic gastritis
 - >40% alcohol (pyloric spasm)
 - Atropine or benzene (less GI motility)

Sample	Relative Concentration (mg%)
Whole blood	1.00
Plasma or serum	1.12 - 1.2
Urine	1.3
Vitreous	1.2
Alveolar air	0.0021
Brain	0.85
CSF	1.1

Driving Limit

- As per Motor Vehicle Act - Blood 30mg %
- In females the blood alcohol will be 25% higher due to,
 - Small aqueous compartment.
 - More fat.
 - Lower activity of alcohol dehydrogenase

Tests Used

- Blood sample is preferred.
- Preservatives
 - NaF, Potassium oxalate (alive)
 - Vitreous humor (autopsy)
- Mnemonic: **KBC Hero**
 - **Kozelka test** → Qualitative
 - **Breath analyzer// Drunkometer** → Infrared rays-based test. → Based on Henry's law → Blood ethanol levels are measured.
 - **Cavett test** → Qualitative
 - **Hine test** → Qualitative
 - **Gas chromatography** → Best test → Quantitative and Qualitative

510 IPC: Misconduct did after alcohol consumption.

Symptoms

- **Stage of excitement**
 - Impairment of cognitive function - 30 mg%.
 - Impaired reaction time - 50mg%.
 - Alcohol/ lateral gaze nystagmus - 80 to 100 mg%.
- **Stage of incoordination**
 - Flushing with rapid pulse
 - 150 mg%
- **Stage of coma**
 - Motor, sensory, speech, and coordination are deeply affected.
 - **McEwan sign is +ve** → Pupil constricted. → Pinched, dilated pupil. → Again, becomes constricted. → >300 mg% → Used to differentiate the type of coma (alcohol or other reason)

prince kumar
princeeeekum@gmail.com
9928609733

Terms to Know

- **Sober:** <10 mg%
- **Drinking:** 10-70 mg%
- **Under influence:** 80-100 mg%
- **Intoxicated:** 150-300 mg%
- **Coma:** >300 mg%

Widmark Formula

Blood, $a = pcr$

Where,

- a = wt of alcohol
- p = body wt
- c = concentration of alcohol in mg%
- r = constant
 - Male - 0.68
 - Female - 0.55



Important Information

- Blood = $\frac{1}{4}$ pcr of urine (1.3mg%)

Alcoholic Withdrawal Symptoms

- Tremors
 - 6-8 hrs
 - 1st symptom
- Hallucination
 - 12 hrs
 - Most common is auditory
- Seizures
 - 12-24 hrs
 - Generalized tonic-clonic
- Delirium tremens - Dangerous
 - 2-3 days (48-72 hrs)
 - Disorientation
 - Time
 - Place
 - Person
 - Confused state.
 - If the crime committed, not punished (exempting under 84 IPC)
 - Automatic activity increased
 - Coarse tremor
 - Hallucinations (visual)

Chronic Alcoholism

- Early: Wernicke's Encephalopathy - Vit B1 deficiency
 - G - Global confusion.
 - O - Ophthalmoplegia.
 - A - Ataxia.
 - P - Polyneuropathy.
- Late: Korsakoff Psychosis - Vit B1 deficiency.
 - C - Confabulation (filling the memory of the brain with stories).
 - A - Anterograde amnesia.
 - R - Retrograde amnesia (rare).
- Mar Chifava's Syndrome
 - Common in male
 - Atrophy of Corpus callosum (demyelination).

- Ataxia
- Dementia
- Coma
- Death

CNS Depressant - Methanol

- Other name: Wood alcohol/ Illicit liquor (illegally made).
- Tragedy: Hooch Tragedy
- Fatal dose: 80-120 ml or 80-200 ml
- Metabolism
 - Methanol to Formaldehyde (Enzyme: Alcohol dehydrogenase).
 - Formaldehyde to Formic acid (Enzyme: Aldehyde dehydrogenase).
- Formic acid causes
 - Metabolic acidosis
 - Retinal damage (snow field vision)



Important Information

- Formaldehyde is 33 times more poisonous than methanol.
- Formic acid is 6 times more poisonous than methanol.

Symptoms

- Severe abdominal cramp (earliest).
- Muscular weakness.
- Snowfield vision and complete vision loss (optic neuritis).
- Fixed and dilated pupil (MCQ).
- CNS and cardiac depression.

Treatment

- Firstly stabilization.
- TOC: Hemodialysis.
- Antidotes
 - 1st - Ethanol (competitive inhibitor for alcohol dehydrogenase).
 - 2nd - Fomepizole (inhibits alcohol dehydrogenase).
- Other
 - Folinic acid (increases excretion of formic acid).
 - Sodium bicarbonate is given to treat acidosis.

Postmortem Findings

- Absence of postmortem clotting.
- Hemorrhagic necrosis of putamen.

Recall: In carbon monoxide poisoning bilateral cavitation necrosis of globus pallidus and putamen



PREVIOUS YEAR QUESTIONS



Q. Hairs are preserved in which poisoning?

(FMGE – DEC – 2019)

- A. Arsenic
- B. Manganese
- C. Phosphorous
- D. Alcohol

Q. Which metal results in "Saturation gout" formation?

(FMGE – JAN – 2018)

- A. Cadmium
- B. Lead
- C. Beryline
- D. Mercury

Dr. H. K. Kulkarni
Dr. H. K. Kulkarni@gmail.com
9920097111



- Study of death.
- Death comes under - S.46 IPC
- Taphonomy is the study of post-mortem changes.
- Components of Bishop's tripod of life:
 - Heart- circulation.
 - Lung - respiration.
 - Brain function.

Types of Death

00:01:44

Somatic death or Clinical death

- Complete and irreversible stoppage of any of Bishop's tripod of life components.
- A loss of one function leads to death.
- Doctor declares the individual dead.

Molecular death or Cellular death

- Occurs 1-2 hours after somatic death.

Supra-vital interval

- Time period between the occurrences of somatic death followed by molecular death.

Bichat's mode of death

- Depends on the dysfunction i.e., may be respiratory, circulatory, or brain function.
- Dysfunction of respiration → Asphyxia.
- Dysfunction of circulation → Syncope.
- Dysfunction of brain function → Coma.
- Asphyxia, syncope, and coma are examples of Bichat's mode of death.

Atria mortis or Gateway of death

- Stoppage of only one component of Bichat's tripod of life (respiration, circulation, or brain function) results in death.
- Example of somatic death.

Suspended animation or Apparent death.

- Signs of life are reduced to a minimal level.
- Resuscitation leads to survival.
- Causes of suspended animation:
 - Prolonged anesthesia.
 - Newborn (most common).
 - Barbiturates poisoning.
 - Cholera.
 - Cachexia.
 - Concussion.
 - Drowning.
 - Electrocutation.

- Hypothermia.
- Hyperthermia.
- Sunstroke.
- Shock.
- Insanity.
- Trance (voluntarily suspended animation seen in yoga practitioners).
- Typhoid (enteric fever).
- Morphine overdose.

Zasko's phenomenon or Tendon reaction

- Occurs 1-2 hours after somatic death.
- Seen during the supra-vital interval.
- Definition-Striking the lower one-third of the quadriceps femoris muscle with a hammer causes upward movement of the patella.
Organ harvesting for transplantation.
- Done during the supra-vital interval.

Post-mortem changes

00:11:09

- Signs of death may be immediate, early, or late.

Immediate signs

- 1st sign is insensibility (loss of sensation) and loss of voluntary power.
- Stoppage of respiration and circulation.

Late signs

- Decomposition signs.
- Putrefaction.
- Autolysis.
- Mummification.

Early signs

- Eye changes.
- Algor mortis.
- Livor mortis.
- Rigor mortis.

Eye changes

Railroading phenomenon or cattle trucking or Kevorkian sign.

- Retinal blood vessels appear segmented or fragmented.
- Seen within a few minutes to one hour after death.
- Seen using an ophthalmoscope.
- **Earliest eye sign.**
- Used to determine time since death (TSD).
- Before the Kevorkian sign, corneal reflexes are lost, and the pupil is dilated.

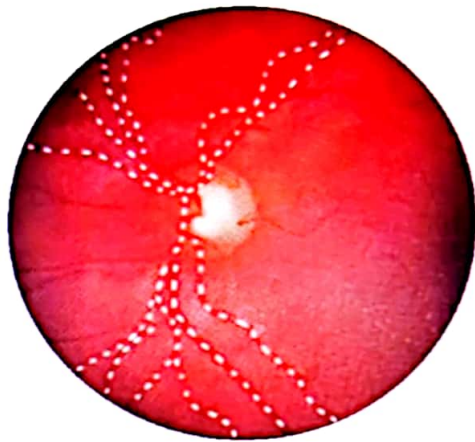

Kevorkian sign

Flaccidity of the eyeball.

- Normal intraocular pressure is 20mmHg.
- Two hours after death, intra-ocular pressure drops to 0 mmHg.
- Used to determine time since death.

Tâche noire sclérotique.

- Change in the sclera.
- Occurs after 3-6 hours post-mortem.
- Triangular area composed of cell debris and mucus with color change from yellow to brown or black.
- Used to determine time since death.

Tache- Noir

**Corneal changes.**

- Hazy cornea occurs after 1 hour.
- Opacity of cornea occurs after 6 hours.

Vitreous humor changes.

- Resist putrefaction i.e., no chemical changes in vitreous humor after putrefaction.
- Linear increase in K^+ and hypoxanthine.
- Decrease in glucose.
- Best for determining time since death.
- Formulas used to determine K^+ content include:
 - Sturner's formula.
 - Madea's formula.

Cooling of the body or Algor mortis

- Seen within 15 minutes after death.
- Core body temperature (CBT) decreases.
- Thanatometer is a chemical thermometer used to measure core body temperature -.
 - It may be 25-30 cm.
 - It can measure temperatures between 0-50°C.
- Ideal site for recording temperature is the rectum (rectal temperature is almost equal to core body temperature).
- Other sites include the inferior surface of the liver, external auditory meatus, nasal spaces, and the lower end of the esophagus.
- Graph illustrating the relationship between temperature and time post-mortem produces a sigmoid curve or inverted S-shape curve.

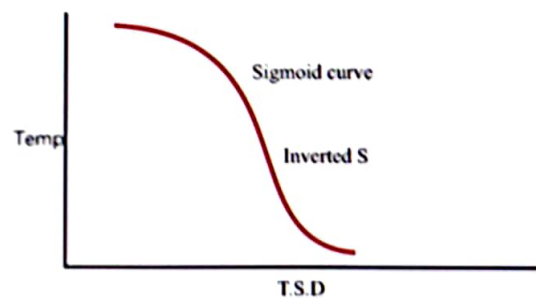

- Stage I: Isothermic phase.
- Stage II: Steep decline.
- Stage III: Gradual decrease.

Rate of fall

- TSD → Time since the death.
- NBT → Normal body temperature.
- ROF → Rate of fall.
- RT → Rectal temperature.
- Rate of fall in temperature post-mortem is 0.4°C-0.6°C/hour or 0.75°F-1.5°F/hour.
 - 0.4°C/hour in summer.
 - 0.6°C/hour in winter.
 - Average rate of fall is 0.5°C/hour $TSD = (NBT-RT)/ROF$

Post-mortem caloricity

- Temperature increases for 1-2 hours after death.
- Causes include:
 - Septicemia (cholera, typhoid).
 - Sun stroke (pontine hemorrhage).
 - Strychnine poisoning (tetanus, exercise).
- In septicemia, there is increased bacterial activity.
- In sunstroke, heat regulation interferes.
- In strychnine poisoning, there is increased muscle activity.

Post-mortem staining

- Also known as post-mortem lividity, hypostasis, livor mortis, vibices, or suggilation.
- Present in dependent parts of the body i.e., areas that do not touch the ground but face towards the ground.



- Gravitational forces cause the pooling of blood in capillaries and venules.
- Accumulation of deoxyhemoglobin blood in the skin causes a bluish-purple appearance.
- Skin discoloration of rete mucosum of the dermis.
- Absent in pressure parts of the body.
- Begins shortly after death i.e., 30 minutes.
- Visible in 2 hours after death.
- Maximum visibility for 6-12 hours.
- Fixation occurs after 7-8 hours.
- Secondary lividity occurs when changing the position of the body before 7-8 hours leading to post-mortem staining in other areas of the body.
- Persists till decomposition.
 - Decomposition changes the skin color to green.

PM staining

Begins	= Shortly After Death = 30 min
Visible	= 2 hr
Maximum	= 6-12 Hrs
Fixation	= 7-8 Hrs
Persist	= Decomposition = Skin Green

Post-mortem staining in different positions

- Supine position → back of the head, back of the neck, back of the chest, back of the leg.
- Prone position → front parts of the body.
- Hanging position → hands and feet i.e., glove and stocking pattern.
- Running water → no post-mortem staining.

Medical importance

- Determines time since death.
- Determines the position of the body at the time of death.
- Determine the cause of death (COD).

Color presentation due to different causes

9928609733

- Carbon monoxide poisoning → Cherry-red.
- Cyanide poisoning → Bright or brick red.
- Hypothermia → Pink.
- Hydrogen sulphide (H₂S) → Blue green.
- Opium → Black.
- Phosphorous or potassium chlorate (KClO₃) → Chocolate brown.
- Nitrites, nitrobenzene, aniline → Chocolate brown.
 - Aniline may produce a blue color.
 - Chocolate brown color formed due to methemoglobin.
- Clostridium perfringens → Bronze.
- Methanol poisoning → Purple.

Rigor Mortis or Cadaveric stiffening or Cadaveric rigidity

00:40:10

- 3 stages muscles undergo after death include:
 - Primary flaccidity phase or primary relaxation phase.
 - Rigor mortis.
 - Secondary flaccidity phase or secondary relaxation phase.
- Primary flaccidity occurs during somatic death.
- Rigor mortis occurs during cellular death.
- Mechanism of rigor mortis is ATP depletion.
- Actin-myosin separation takes place in primary flaccidity.
- Lack of actin-myosin separation causes rigor mortis.
- Secondary flaccidity occurs when decomposition starts.
 - Actin and myosin filaments are broken down leading to separation.
- When rigor mortis starts, ATP decreases to 85% of the normal content.
- At maximum rigor mortis, ATP decreases to 15-30% of the normal content.
- Rigor mortis refers to muscle stiffening, some shortening, and opacification of the fibres.

**Occurrence of rigor mortis in muscles**

- Begins 1-2 hours after death.
- Seen in all muscles were voluntary or involuntary.
- 1st muscle affected is the myocardium.
- 1st external muscle affected is the upper eyelid muscle i.e., orbicularis oculi.
- Sequence in which external muscles are affected:
 - Eyelid muscles → Neck → Lower jaw → Muscles of face → Muscles of chest → Upper limbs → Abdomen → Lower limbs → Fingers and toes

Nysten Law

- Rigor mortis develops from the upper parts of the body towards the lower parts of the body.

Shapiro's Law

- Rigor mortis develops in all muscles at the same time.
- This law has been disproven.

Same order

- Rigor mortis disappears in the same order that it appears.
- It will disappear first from the upper eyelid and last from the fingers and toes.

Rule of 12

- In the first 12 hours after death, rigor mortis appears in all body muscles.
- In the next 12 hours, it persists in all body muscles.
- In the next 12 hours, it disappears from all body muscles.
- Rigor mortis appears and disappears within 36-48 hours after death, thereby aiding in the determination of time since death.

Rigor mortis in a fetus

- In fetuses < 7 months of age, rigor mortis is absent.
- Actin and myosin filaments have not developed.
- Rigor mortis appearance according to seasons
- In summer, it is seen in 18-36 hours.
- In winter, it is seen 24-48 hours.

Rigor mortis appearance in wasting diseases.

- Muscle mass is thin with decreased ATP storage
- Diseases such as cholera, TB, cancer, cachexia, and typhoid.
- Early onset of rigor mortis with short duration.

Rigor mortis appear in violent death.

- Cases such as cutthroat injury or firearm injury.
- Early onset rigor mortis with short duration.

Exceptions

- Strychnine poisoning → Early onset rigor mortis with long duration.
- Arsenic poisoning → Late onset rigor mortis with long duration.

Rigor mortis appearance in thick muscle

- Increased ATP storage.
- Late onset rigor mortis.

Causes of muscle stiffening after death

00:53:10

1. Rigor mortis.
2. Heat stiffening.
3. Cold stiffening.

4. Gas stiffening.
5. Cadaveric spasm.

Heat stiffening

- Also known as boxing attitude or pugilistic attitude or fencing attitude.
- Surrounding external temperature is $\geq 65^{\circ}\text{C}$.
- Mechanism involves the coagulation of muscle protein.
- Normal rigor mortis is not seen.
- Persists till decomposition occurs.

Cold stiffening

- Surrounding external temperature is $\leq -5^{\circ}\text{C}$.
- Mechanism involves freezing of the body fluid and hardening of the subcutaneous tissue.
- In warm temperature, cold stiffening disappears.
- Normal rigor is present.

Gas stiffening

- Mechanism involves the release of gas during decomposition.

Cadaveric spasm

- Also known as cataleptic rigidity or instantaneous rigor.
- Mechanism involves ATP depletion.
- Muscle contracted during life remains rigid and stiff after death.
- Occurs immediately after death.
- Primary relaxation is absent.
- Secondary relaxation is present.
- An exclusively ante-mortem event.

Cadaveric Spasm



- Causes of cadaveric spasm:
 - Asphyxial death.
 - Brain injury.
 - Cerebral injury.
 - Drowning.
 - Dinitroresol poisoning.
 - Excitement.
 - Fear.
 - Firearm e.g., in suicide.

	Cadaveric spasm	Rigor mortis
Time	Immediately after death.	1-2 hours after death.
Muscles	Mainly involves voluntary muscles. Generally, involves a short group of muscles e.g. hand muscles.	Involves both voluntary and involuntary muscles.
Primary relaxation	Absent.	Present.
Molecular death	Absent.	Present.
Electric stimuli	Response present.	Response absent.
Importance	Describes the manner of death.	Determines time since death.

Decomposition

01:02:41

- Two mechanisms: autolysis and putrefaction.

Autolysis

- Body enzymes cause cell lysis.
- Examples of autolytic changes:
 - Clouding of cornea- 1st external change.
 - Changes in brain glandular tissue-1st internal change.
- Aseptic autolysis involves the mummification of the fetus in intra-uterine death.

Putrefaction

- Stimulated by bacterial activity.
- Most common bacteria involved is Clostridium welchii or Clostridium perfringens.
- Most common enzyme involved is lytic lecithinase
- Three stages of change:
 - Color change.
 - Gas formation.
 - Liquefaction of tissue.

Colour change

- 1st internal/overall change of putrefaction is reddish-brown discoloration of aortic intima.
- 1st external change is green discoloration of the right iliac fossa.
- Mechanism:
 - Bacteria forms hydrogen sulphide.
 - Cecum located beneath the right iliac fossa has maximum bacterial activity.
 - Skin lies superficial to the cecum.
 - Sulphur combines with hemoglobin to form a green color compound.
- In summer, discoloration starts in 12-18 hours.
- In winter, discoloration starts in 1-2 days.

Decomposition-Green Discolouration of Body



Marbling

- Discoloration of prominent superficial veins to green-brown color.
- Corresponds to the vascular channel.
- Mechanism: Clostridium welchii bacteria form hydrogen sulphide gas in the superficial veins with the formation of green, brown sulphahemoglobin.
- Starts in 24 hours.
- Prominent in 36-48 hours.
- Helps in determining time since death.
- Seen in the chest, shoulder, abdomen, and thigh.

Marbling



Filigree burn.

- Lightning injury.
 - Pink discoloration.
- Does not correspond to the vascular channel.

Maggots

- Larvae of flies i.e., Musca domestica or Musca vicina.
- Forensic entomology deals with the study of maggots and flies at different stages.
- Developmental stages of flies:
 - Maggots -larvae, seen on the body after 1-2 days.
 - Pupae -seen on the body after 3-6 days.
 - Adult flies.
- Complete development of an adult fly from its larval form takes 5-10 days.
- In winter, it takes 8-20 days.
- Maggots are first seen in the natural orifices.
- In cases of poisoning, poison can be detected in the maggots and pupae i.e., forensic entemo-toxicology.
- Important criteria in deciding time since death.
- Maggot staging was proposed by Megnin.

Maggots



Post-mortem purge

- Gas formation during decomposition leads to the expulsion of blood-stained froth and gastric contents from the nose and mouth.
- Seen after 2-3 days.

Post-mortem luminescence

- Body emits light after death.
- Causes:
 - Bacterial e.g., photobacteria presence.
 - Fungal e.g., Armillaria, Ram's bottom.

Time sequence of significant changes

- Gas stiffening and post-mortem purge → 2-3 days.
- Uterine and anal prolapse → 2-3 days.
- Loose hair and nails → 3-5 days.
- Skin peeled off → 3-5 days.
- Pattern: skin peeling starts in the hands and legs i.e., glove and stocking pattern.
- Colliquative putrefaction i.e., liquefaction of tissue → 5-10 days.

Putrefaction sequence

- 1st organs to decompose are the larynx and trachea due to their direct contact to air.
- Followed by (in order):
 - Stomach, spleen, and small intestine.
 - Liver and lung.
 - Brain, heart, kidney, uterus.
 - Skin, muscle, tendon, bone/tooth.
- Non-gravid uterus is the last organ to decompose in females.
- Prostrate is the last organ to decompose in males.
- The overall last organ to decompose is bone/tooth.

Important points of putrefaction

- Liver shows gas formation up to 24-36 hours i.e., foamy liver or honeycomb liver.
- Optimum temperature for decomposition is 21-38°C.
- Decomposition starts at > 10°C.
- Poisons inhibiting putrefaction include:
 - Strychnine.
 - Metallic poison e.g. arsenic, antimony, thallium.

- Carbon monoxide.
- Cyanide.
- Carbolic acid.
- 1st amino acid that disappears from bone in decomposition is proline.
- 2nd amino acid to disappear is hydroxyproline.
- Last amino acid to disappear to glycine.
- Bones that are 100 years old have < 7 amino acids.

prince kumar
princeeeekum@gmail.com

Caper Dictum

01:24:55

- Formula proposed by Taylor.
- Shows the relationship between the rate of decomposition in air, water and soil (earth).
- Air > Water > Earth.
- If decomposition in the air takes 1 week, it will take 2 weeks in water and 8 weeks in soil.
- Air has the fastest rate of decomposition.

Modification of Putrefaction

Adipocere or saponification or grave wax

- Seen in warm, humid climates or if the body is immersed in water.
- Clostridium welchii bacteria.
- Intrinsic lipase enzyme.
- Sites include the face, breast, buttocks, and abdomen i.e., fatty areas.
- Mechanism: Fat is converted to fatty acids that undergo hydrolysis and hydrogenation in the presence of lipase to combine with Ca²⁺ or NH₄⁺ to form soap.
- Ammonical, offensive or sweetish smell like a rancid butter.
- The smell propagates to the clothes of the autopsy surgeon i.e., pseudosmell.
- Two types of adipocere:
 - Fresh - soft, moist, white, greasy.
 - Old - dry, hard, brittle, yellow.
- Time required for adipocere formation is 3 days to 3 months.
- Absent in fetus < 7 months.

Adipocere



- Medical importance:
 - Describe the climate at time of death.
 - Determination of time since death.
 - Preservation of dead body for easy identification.

Mummification

- Seen in dry and hot climates leading to dehydration of the body.
- Natural features of the body preserved.
- 60-70% of body weight is lost.
- Time required for mummification is 3 months to 12 months.
- Arsenic and antimony favors the mummification.
- Important feature of intra-uterine death.



- Medical importance:
 - Describes climate at the time of death.
 - Determination of time since death.
 - Identification is comparatively very easy.

Embalming or Thanatopraxia

- Used to preserve dead bodies.
- Should be used within 6 hours of death.

Composition of embalming fluid

Preservative	<ul style="list-style-type: none"> • Formalin. • Formaldehyde. • Methanol.
Antiseptic/Germicide	<ul style="list-style-type: none"> • Phenol.
Wetting agent	<ul style="list-style-type: none"> • Glycerine. • Glycerol.
Anticoagulant	<ul style="list-style-type: none"> • Sodium citrate.
Buffer	<ul style="list-style-type: none"> • Sodium bicarbonate. • Sodium carbonate. • Sodium chloride.
Vehicle	<ul style="list-style-type: none"> • Water.

- Ethanol is not a part of embalming fluid.

Embalming methods

- Arterial.
- Cavity.
- Surface embalming (not commonly used).
- Best method is a discontinuous injection and discontinuous drainage.
- High pressure/low volume method also used.
- Best vessel is the femoral artery.
- Embalming is always done after a post-mortem or receiving the death certificate.
- If embalming is done before postmortem then the doctor will be punished under 201 IPC for disappearance of evidence.
- Body preservation for an unknown dead body done for at least 72 hours.
- Presumption of survivorship → 107 IEA.
 - Nothing is suggestive of death; the person is presumed alive for the next 30 years.
- Presumption of death → 108 IEA.
 - Nothing has been heard about a person from family or relatives for 7 years.

Emptying of stomach

- Determination of time since death.
- Light meal after 1-2 hours.
- Medium-sized meal after 3-4 hours.
- Heavy meal after 5-8 hours.
- Identification of stomach contents done if there was ingestion of food within 2 hours.

Ante-mortem vs Post-mortem blister

01:43:00

	Ante-mortem blister	Post-mortem blister
Content	Inflammation. Chloride. Protein (mainly, albumin).	Gas.
Base	Erythematous.	Pale.
Redness	Present.	Absent.
Enzymatic/ Vital reaction	Present.	Absent.



CROSS WORD PUZZLES



Crossword Puzzle

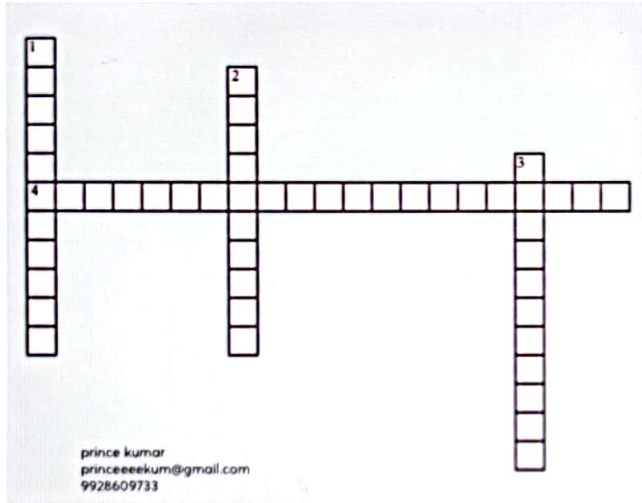

Across

4. Change in the sclera

Down

1. Study of death
2. Rigor mortis develops in all muscles at the same time.
3. Begins 1-2 hours after death



- Forensic + Psychiatry
- It is the application of **forensic medicine** in psychiatry
- Forensic psychiatry is used for the **law and justice**.

Insane

00:00:51

- A person who is **mentally ill**
- If a person commits a crime may be due to two components.
 - Mens rea
 - Actus reus

Components of Insane	Explanation
Mens rea	<ul style="list-style-type: none"> • Mens: Mind • rea: Criminal • Criminal mind and intent or guilt
Actus reus	<ul style="list-style-type: none"> • It is a forbidden act. • If an insane person commits the crime (Actus reus) • There will be no criminal mind involvement. • If the insane commit the crime then he is not responsible for the crime

Criminal Responsibility of Insane

- For the criminal responsibility of the insane we use a law
 - McNaughten Rule

McNaughten Rule

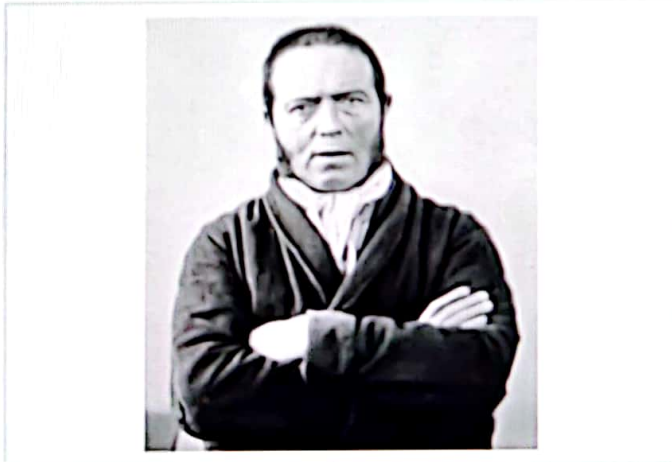

- It is implemented in **1843**.
- **Other Names:** The **right or wrong test** or the **legal test**
- McNaughten is an Insane person and committed the crime (Death) because he was suffering from a mental disease **Paranoid schizophrenia**.

- This law includes
 - "An accused person is not legally responsible, if it is clearly proved, that at the time of committing the crime, he was suffering from **defect of reason from an abnormality of mind**, that he did not know the nature and quality of the act he was doing, or that what he has done something wrong."
- It is based on the **84 IPC**.

84 IPC

"Nothing is an offense which is done by a person, who at the time of doing it, by reason of **unsoundness of mind**, is incapable of knowing the nature of the act, or that he is doing what is either wrong or contrary to law".

Drunkenness

- 85 IPC and 86 IPC are not related to insanity.
- **85 IPC:** Involuntary intoxication
- **86 IPC:** Voluntary drunkenness

What is 85 IPC?

An act done by a person, who is incapable of knowing the nature of the act due to intoxication is not an offense if something which **intoxicated him** was administered to him without his knowledge or against his will.

What is 86 IPC?

A voluntarily intoxicated person (**voluntary drunkenness**) is criminally responsible if he had the intention or knowledge of committing the crime

Insanity Laws or Rules

Laws or rules	Implementation
American Law Institute Test	1972
Brawners Rule	Not used nowadays
Currens Rule or Currens Law	1961
Durham's Rule	1954
E: Irresistible Impulse Test or New Hampshire Doctrine	

American Law Institute (ALI) test

A person is not responsible for criminal conduct, if at the time of such conduct, as a result of mental disease or defect, he lacks adequate capacity either to appreciate the criminality of his conduct or to adjust his conduct to the requirements of the law.

prince kumar
princeeeekum@gmail.com
9928609733

- It can be recognized as AAA.
 - A: American Law
 - A: Appreciate the criminality
 - A: Adjust his conduct

Currens Rule:

An accused person is not criminally responsible if, at the time of committing the act, he did not have the **capacity to regulate his conduct** to the requirements of the law, as a result of mental disease or defect.

- It can also be recognized
 - C: Curren's rule
 - C: Capacity to regulate
 - C: Conduct
- The rule is the same as the Brawners, they also use capacity
- But it is a Substantial capacity.

Durham Rule

- **Other Name: Product test**

An accused person is not criminally responsible if his unlawful act is the **product** of a mental disease or mental defect.

Irresistible Impulse Test

It states that an accused person is not criminally responsible, even if he knows the nature and quality of his act and knows that it is wrong if he is **incapable of restraining himself** from committing the act because the free agency of his will has been destroyed by mental disease.

Civil Responsibility of Insane

It includes.

- Testamentary Capacity
- Holograph

Testamentary Capacity

- **Testament:** Will
- It is defined as the **mental capacity** to make a **valid will**.
- If you are making a will then you are considered a **Testator**
- **Requirements**
 - **Sound mind:** Compos mentis
 - It should be certified by a doctor
 - Age should be above or equal to **18 years**.
- Unsound people cannot write the will
- It is related to the **31 IPC**.

Holography

Writing the will with your **own handwriting**

Civil Responsibility also includes.

- A manager is appointed if an insane person is incapable of managing his property.
- A contract is invalid during the period of insanity.

- Married an Insane person then the marriage is considered **null void or zero marriage**.
- Marriage and consent are invalid (90 IPC)
- If a person became **insane** after marriage, then the **marriage is valid**
- If a person became insane after marriage for **3 years**, then the party can file a case for divorce.
- There is no age limit for giving evidence or testifying (**One part of 118 IEA**)
- Insane person is not competent to testify in court if he is unable to understand the question put to him (**118 IEA**)

Lucid Interval

00:21:24

- The insane person became sane (**Normal**) and after some time the person again became **insane**.
- Hence, this period is considered the lucid interval.

Insane



Sane



Insane

- It is also discussed in **traumatology** like in
 - Extradural hematoma
 - Subdural hematoma
- In this condition, if you have committed a crime then you are responsible for the crime
- You can also act as a witness by providing evidence to the court.

Perception Disorder

00:22:36

- False sense of perception
- It is of two types.
 - Hallucination
 - Illusion

Hallucination

- It is the **first** perception disorder.
- In this condition, a person will experience a **false perception**.
- In this condition, the **external stimulus is absent**.
- There are different types of hallucinations, they include.
 - Visual (sight) hallucination
 - Auditory (sound) hallucination
 - Olfactory (smell or odor) hallucination
 - Gustatory (taste) hallucination
 - Tactile (touch) hallucination
- Example: Magnan Syndrome or cocaine bugs

Illusion

- It is a second type of perception disorder
- External **stimulus is present**, but the person will **misinterpret** it
- **Example:** A rope is in front of you, but you misinterpret it as a snake

VOFA

- Visual hallucination common in organic disease
- Auditory hallucination common in functional disorder

Q1. The most common functional disorder in psychiatric disorders is?

Ans: Auditory hallucination

Thought Disorder

00:26:11

Delusion:

- It is a disorder, where the content of thought changes.
- False, firm, and fixed belief in something which is not a fact and that persists even after its falsity has been clearly demonstrated.
- This is known as delusion.

Types of Delusions

Types of Delusions	Description
Persecution	<ul style="list-style-type: none"> • Most common delusion disorder. • It is a delusion of harm or killing
Grandeur	<ul style="list-style-type: none"> • Other Name: Exaltation • Superiority image for yourself. • It is most common in mania.
Nihilistic	<ul style="list-style-type: none"> • Imagines he does not exist or there is no world. • It is most common in depression.
Infidelity	<ul style="list-style-type: none"> • Patient might think that his or her partner is not loyal or unfaithful to him. • Other Names: Othello syndrome, Morbid jealousy • It is most common in <ul style="list-style-type: none"> ○ Alcoholic patients ○ Cannabis abuse ○ Psychosis • It is more common in male than in female
Erotomania	<ul style="list-style-type: none"> • Other Name: De Clerambault's syndrome • It is a delusion of love. • More common in females than males
Hypochondriacal	<ul style="list-style-type: none"> • Patient believes that something is wrong with his body or belief of having a serious disease (like cancer)
Delusion of influence/control	<ul style="list-style-type: none"> • A person believes that his thoughts, emotions, and actions are influenced and controlled by some external agencies like telepathy, radio, or external

Delusion of Reference

- A person believes that he is being referred to by all agencies, media, and persons around him in any occurrences concerning him.

Cotard syndrome

- It is a type of tiredness.
- A delusional belief that he is dead, lost his blood or internal organs, and is putrefying.

Delusion of Double

Delusion of double	Description
Capgras Syndrome	<ul style="list-style-type: none"> • For remembrance it was written as Cafgras • F: Familiar person • S: Stranger • Familiar person is considered as a stranger • For example: <ul style="list-style-type: none"> ○ A person is standing in front of view and saying he is your brother, but you are not believing him ○ You are thinking him as a imposter or double of your brother
Fregoli Syndrome	<ul style="list-style-type: none"> • Strangers are considered as a familiar person. • For example: <ul style="list-style-type: none"> ○ A bagger is standing in front of you but you're thinking him as your boss



CROSS WORD PUZZLES



Crossword Puzzle

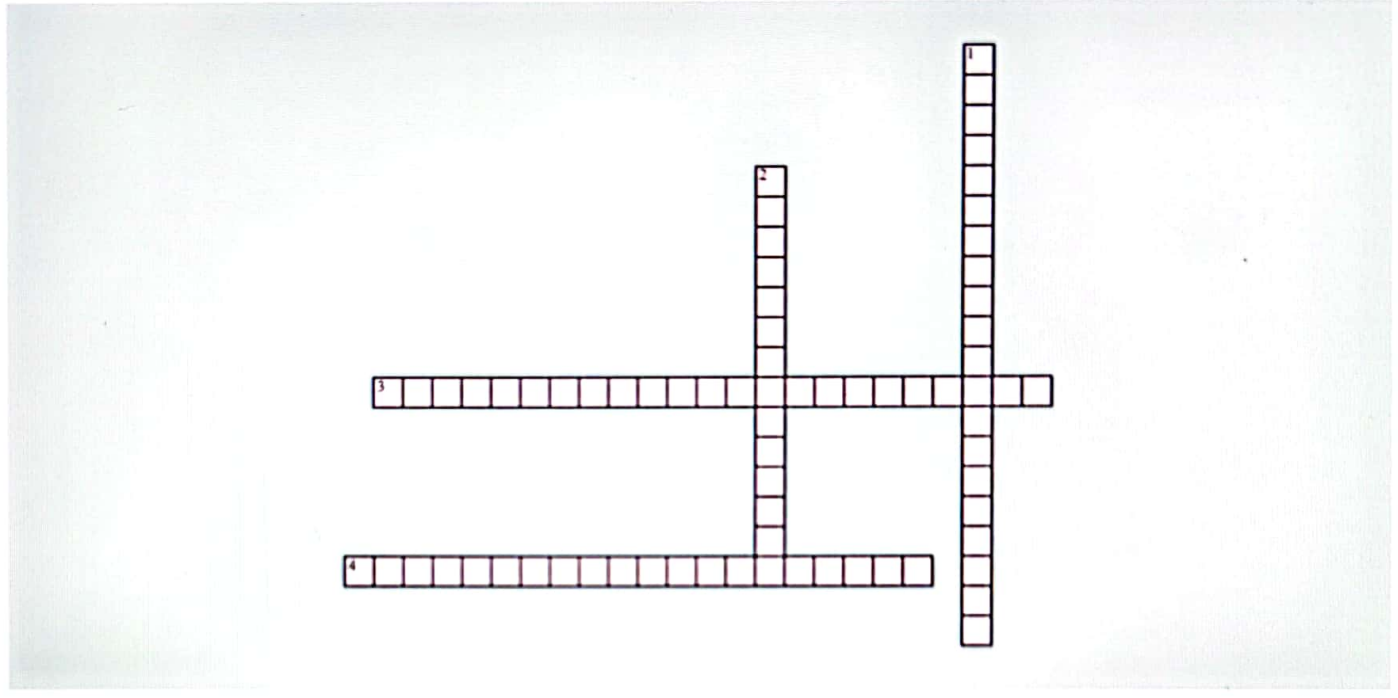

Across

- 3. 85 IPC
- 4. 86 IPC

Down

- 1. ALI
- 2. Criminal Responsibility of Insane

prince kumar
 princekumar@gmail.com
 9928609733



Phobia

Phobia - Fear

• **Types**

- Agoraphobia - Public/ Crowd
- Claustrophobia - Closed spaces
- Acrophobia - Height
- Nyctophobia - Darkness (night)
- Mysophobia - Germs/ Dirt
- Hydrophobia - Water
- Glossophobia - Public speaking
- Trypanophobia - Injection/ Needles
- Arachnophobia - Spiders
- Nomophobia - Without mobiles
- Thanatophobia - Death
- Phobophobia - Fear from the phobia

Impulse

00:02:53

- Sudden and irresistible force compelling a person to do some action.
- Insight is present and the person is conscious.
- Done without any motive or forethought.
- **Types**
 - Kleptomania - Desire to steal things of less value.
 - Onlomania - Impulse to buy things.
 - Dipsomania - Drinking alcohol at a periodic interval
 - Pyromania - Desire to set fire to things.
 - Mutilomania - Desire to mutilate animals.
 - Trichotillomania - Plucking out your hair.

Mental Health Care (MHC) Act 2017

Changes as per the act

- **Mental illness:** Disorder of mood, thought, perception, orientation, and memory that causes.
 - Significant distress to a person
 - Impaired ability to meet demands of daily life
 - Includes mental conditions associated with alcohol and drug abuse.
 - Doesn't include mental retardation (IQ < 70)
- Psychiatry hospital to a mental health establishment
- Decriminalizing suicide attempts (IPC 309)
 - Sec 115 of MHC Act 2017: IPC 309 is removed nowadays as people who attempt suicide are already under stress.
- Prohibiting ECT (Electroconvulsive Treatment) without the use of anesthesia and muscle relaxants for adults. **For minor no ECT**
- Protection of rights of persons with mental illness.
 - Right of confidentiality

- Right to access medical records
- Informed consent from the mentally ill person (if not, the mental health review board can sign)
- Prohibition on sterilization of men or women as a mode of treatment for mental illness
- Prohibition on any form of chaining of persons.
- Establishment of Central and state mental health authority

Advance Directive

prince kumar
princeeeekumar@gmail.com
9928609733

- **Direction in advance for mental illness**
- Any major can write an advance directive.
 - To specify an individual's health care decisions
 - Way to be treated.
 - Way not to be treated.
 - To identify persons who will take those decisions for the said individual in the event that he is unable to communicate his wishes to the doctor in the future (nominated representative)

True Insanity vs Feigned Insanity

- Feigned insanity - **Motive is present.**
- Insanity - **Acting like insane.**

Trait	Insanity	Feigned Insanity
Onset and motive	Gradual with no motive	Sudden with some motive
Sign & Symptoms	Uniform and present whether he is observed or not	Present only when conscious being observed
Frequent examination	Does not mind	Resents for fear of detection
Facia Expression	Peculiar vacant look	No peculiarity
Mood, sleep pattern, habit	Abnormal	Normal
Predisposing factor	Present	Absent

Q. In which insanity motive is present?

Ans: Feigned insanity

Criminal Responsibility in Some Cases

- **Delirium tremors (DT)**
 - Alcohol withdrawal symptom
 - Seen in 2 (D) to 3 (T) days of withdrawal.
 - If a crime is committed - **not responsible**

Telegram - @nextprepladdernotes



- **Run amok.**
 - Chronic cannabis abuse symptom
 - Can develop a homicidal tendency.
 - If a crime is committed - **not responsible**
- **Somnambulism**
 - Sleepwalking
 - If a crime is committed - **not responsible**
- **Sleep drunkenness**
 - Another name: Somnolentia
 - Awake and drowsy or confused for long-time
 - If a crime is committed - **not responsible**
- **Kleptomania**
 - Steal article of low value
 - Insight is present.
 - Liable if crime is **committed**.
- **Hypnosis**
 - Hypnotized by someone.
 - **Both persons (hypnotizing and hypnotized) are liable**

pratik kumar
pratik.kumar@gmail.com
9936609711



PREVIOUS YEAR QUESTIONS



Q. A person is criminally not responsible for his action if at the time of doing it by reason of unsoundness of mind. In incapable of knowing the nature of his action or that he is doing what is either wrong or contrary to the law?

(AIIMS - Nov - 2017)

- A. Mc Naughton rule
- B. Curren's rule
- C. Durham's rule
- D. Irresistible impulse test

Q. As per mental health act, an individual with a known psychotic disorder on treatment and is not a minor. can choose to decide the caretaker and course of treatment. This is called as?

(AIIMS - Nov - 2018)

- A. Advance directive
- B. Treatment directive
- C. Mental will
- D. Future directive

Q. A 14-year female in the school is brought to principal by teacher that she is always crying inattentive. not taking interest in any activity. On further investigation that girl told that she was inappropriately touched by her uncle at private parts at her home. Whom should principal inform?

(FMGE - Aug - 2020)

- A. Child welfare committee
- B. Parents
- C. Police
- D. Magistrate



CROSS WORD PUZZLES



Crossword Puzzle

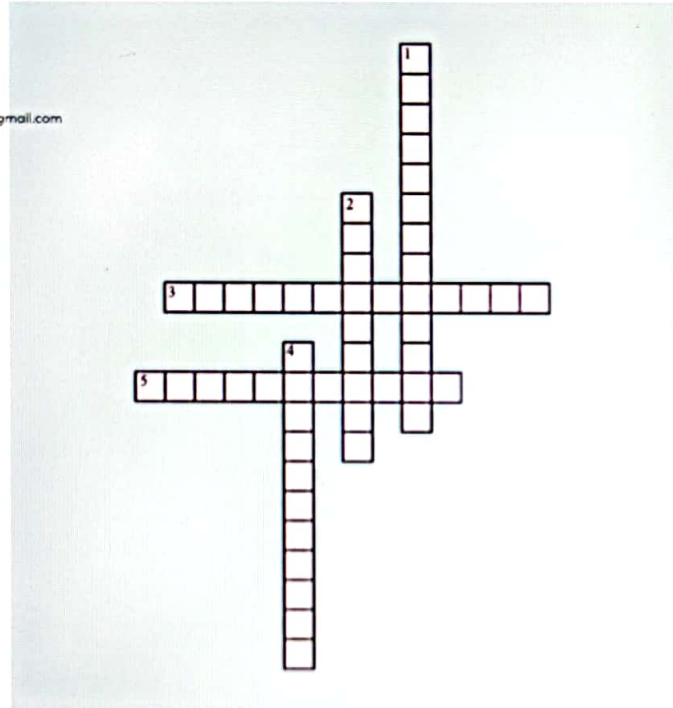

Across

- 3. death
- 5. Sleep drunkenness

Down

- 1. Injection/ Needles
- 2. Desire to set fire to the things
- 4. Steal article of low value

prince kumar
 princeeeekum@gmail.com
 9928609733